

KBL005-KBL10

Silicon Bridge Rectifiers

VOLTAGE RANGE: 50 --- 1000 V

CURRENT: 4.0 A

KBL



Features

- Rating to 1000V PRV
- Surge overload rating to 150 Amperes peak
- Ideal for printed circuit board
- Reliable low cost construction utilizing molded plastic technique results in inexpensive product
- Lead solderable per MIL-STD-202 method 208

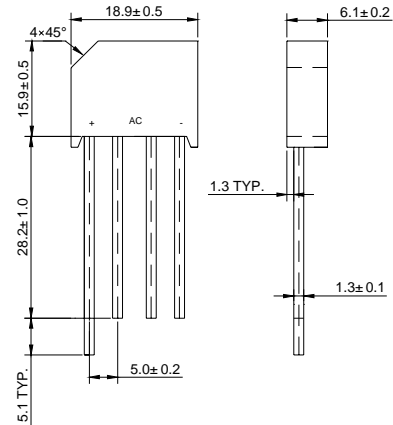

Dimensions in millimeters

MAXIMUM RATINGS AND ELECTRICAL CHARACTERISTICS

Ratings at 25 °C ambient temperature unless otherwise specified.

Single phase, half wave, 60 Hz, resistive or inductive load. For capacitive load, derate by 20%.

| | | KBL005 | KBL01 | KBL02 | KBL03 | KBL04 | KBL06 | KBL08 | KBL10 | UNITS |
|---|------------|-----------------|-------|-------|-------|-------|-------|-------|-------|---------------|
| Maximum recurrent peak reverse voltage | V_{RRM} | 50 | 100 | 200 | 300 | 400 | 600 | 800 | 1000 | V |
| Maximum RMS voltage | V_{RMS} | 35 | 70 | 140 | 210 | 280 | 420 | 560 | 700 | V |
| Maximum DC blocking voltage | V_{DC} | 50 | 100 | 200 | 300 | 400 | 600 | 800 | 1000 | V |
| Maximum average forward Output current @ $T_A=50$ | $I_{(AV)}$ | 4.0 | | | | | | | | A |
| Peak forward surge current 8.3ms single half-sine-wave superimposed on rated load | I_{FSM} | 150 | | | | | | | | A |
| Maximum instantaneous forward voltage at 2.0 A | V_F | 1.0 | | | | | | | | V |
| Maximum reverse current @ $T_A=25$ at rated DC blocking voltage @ $T_A=100$ | I_R | 10 1 | | | | | | | | μA mA |
| Operating junction temperature range | T_j | - 55 ---- + 150 | | | | | | | | |
| Storage temperature range | T_{STG} | - 55 ---- + 150 | | | | | | | | |

KBL005-KBL10

Silicon Bridge Rectifiers

Ratings AND Characteristic Curves

FIG.1 – TYPICAL FORWARD CURRENT DERATING CURVE

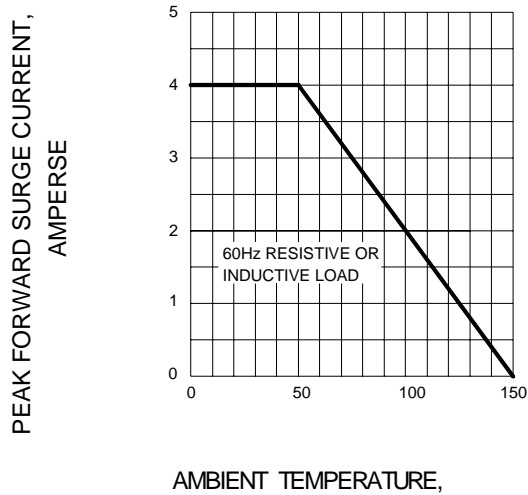

FIG.2 – MAXIMUM FORWARD SURGE CURRENT

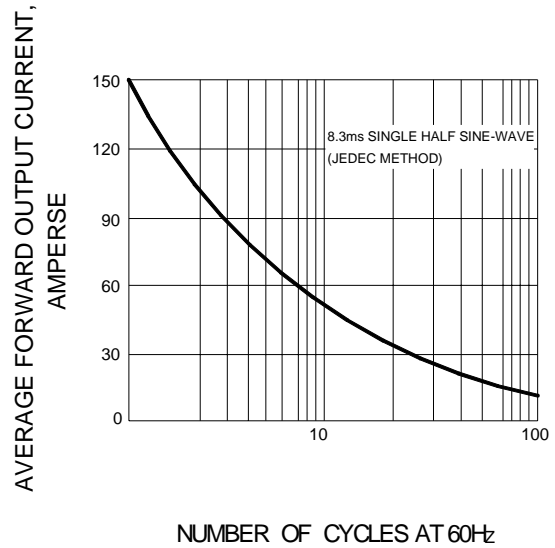

FIG.3 – TYPICAL FORWARD CHARACTERISTIC

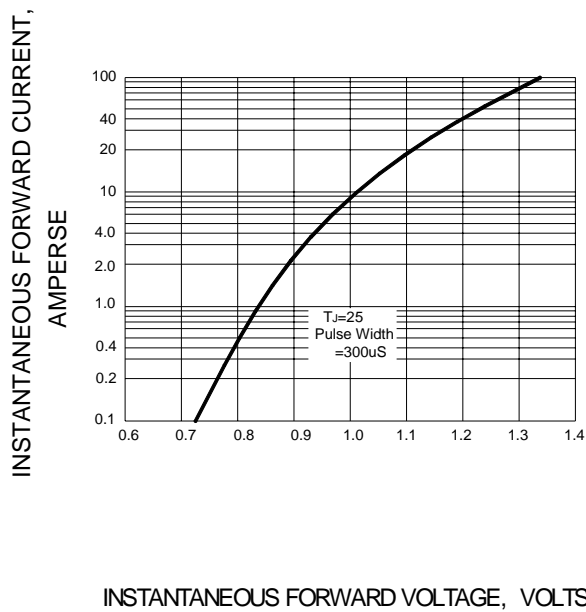

FIG.4 – TYPICAL REVERSE CHARACTERISTIC

