

COMLINEAR[®] CLC1011, CLC2011, CLC4011

Low Power, Low Cost, Rail-to-Rail I/O Amplifiers



FEATURES

- 136µA supply current
- 4.9MHz bandwidth
- Output swings to within 20mV of either rail
- Input voltage range exceeds the rail by >250mV
- 5.3V/µs slew rate
- 21nV/√Hz input voltage noise
- 16mA output current
- Fully specified at 2.7V and 5V supplies
- CLC1011: Pb-free SOT23-5, SC70-5, SOIC-8
- CLC2011: Pb-free SOIC-8, MSOP-8
- CLC4011: Pb-free SOIC-14, TSSOP-14

APPLICATIONS

- Portable/battery-powered applications
- PCMCIA, USB
- Mobile communications, cell phones, pagers
- ADC buffer
- Active filters
- Portable test instruments
- Notebooks and PDA's
- Signal conditioning
- Medical Equipment
- Portable medical instrumentation

General Description

The COMLINEAR CLC1011 (single), CLC2011 (dual), and CLC4011 (quad) are ultra-low cost, low power, voltage feedback amplifiers. At 5V, the CLCx011 family uses only 160µA of supply current per amplifier and are designed to operate from a supply range of 2.5V to 5.5V (± 1.25 to ± 2.75). The input voltage range exceeds the negative and positive rails.

The CLCx011 family of amplifiers offer high bipolar performance at a low CMOS prices. They offer superior dynamic performance with 4.9MHz small signal bandwidths and 5.3V/µs slew rates. The combination of low power, high bandwidth, and rail-to-rail performance make the CLCx011 amplifiers well suited for battery-powered communication/computing systems

Typical Performance Examples

Large Signal Frequency Response

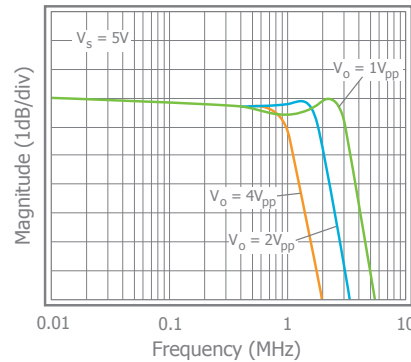

Output Swing vs. Load

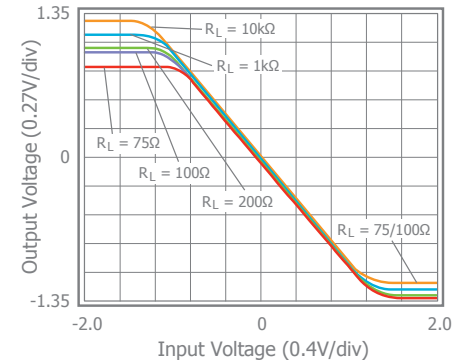

Ordering Information

Part Number	Package	Pb-Free	RoHS Compliant	Operating Temperature Range	Packaging Method
CLC1011ISC5X*	SC70-5	Yes	Yes	-40°C to +85°C	Reel
CLC1011IST5X*	SOT23-5	Yes	Yes	-40°C to +85°C	Reel
CLC2011ISO8X*	SOIC-8	Yes	Yes	-40°C to +85°C	Reel
CLC2011IMP8X*	MSOP-8	Yes	Yes	-40°C to +85°C	Reel
CLC4011ISO14X*	SOIC-14	Yes	Yes	-40°C to +85°C	Reel
CLC4011ITP14X*	TSSOP-14	Yes	Yes	-40°C to +85°C	Reel

Moisture sensitivity level for all parts is MSL-1. *Advance Information.

COMLINEAR CLC1011, CLC2011, CLC4011 Low Power, Low Cost, Rail-to-Rail I/O Amplifiers Rev 0.0.1



CLC1011 Pin Configuration

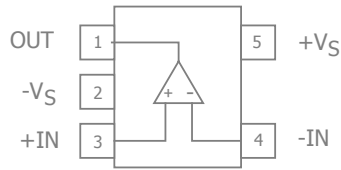

CLC1011 Pin Assignments

Pin No.	Pin Name	Description
1	OUT	Output
2	-VS	Negative supply
3	+IN	Positive input
4	-IN	Negative input
5	+VS	Positive supply

CLC2011 Pin Configuration

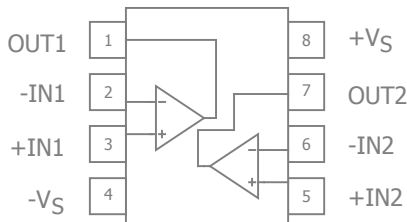

CLC2011 Pin Configuration

Pin No.	Pin Name	Description
1	OUT1	Output, channel 1
2	-IN1	Negative input, channel 1
3	+IN1	Positive input, channel 1
4	-VS	Negative supply
5	+IN2	Positive input, channel 2
6	-IN2	Negative input, channel 2
7	OUT2	Output, channel 2
8	+VS	Positive supply

CLC4011 Pin Configuration

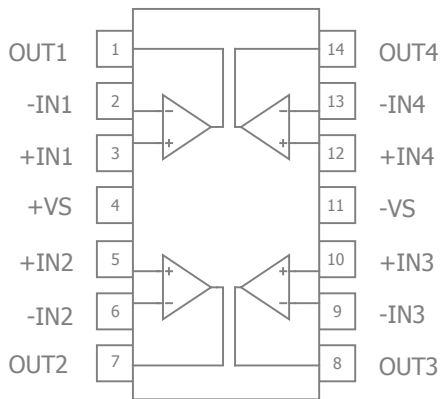

CLC4011 Pin Configuration

Pin No.	Pin Name	Description
1	OUT1	Output, channel 1
2	-IN1	Negative input, channel 1
3	+IN1	Positive input, channel 1
4	+VS	Positive supply
5	+IN2	Positive input, channel 2
6	-IN2	Negative input, channel 2
7	OUT2	Output, channel 2
8	OUT3	Output, channel 3
9	-IN3	Negative input, channel 3
10	+IN3	Positive input, channel 3
11	-VS	Negative supply
12	+IN4	Positive input, channel 4
13	-IN4	Negative input, channel 4
14	OUT4	Output, channel 4



Absolute Maximum Ratings

The safety of the device is not guaranteed when it is operated above the "Absolute Maximum Ratings". The device should not be operated at these "absolute" limits. Adhere to the "Recommended Operating Conditions" for proper device function. The information contained in the Electrical Characteristics tables and Typical Performance plots reflect the operating conditions noted on the tables and plots.

Parameter	Min	Max	Unit
Supply Voltage	0	6	V
Input Voltage Range	$-V_S - 0.5V$	$+V_S + 0.5V$	V
Continuous Output Current	-30	30	mA

Reliability Information

Parameter	Min	Typ	Max	Unit
Junction Temperature			175	°C
Storage Temperature Range	-65		150	°C
Lead Temperature (Soldering, 10s)			260	°C
Package Thermal Resistance				
5-Lead SC70		TBD		°C/W
5-Lead SOT23		TBD		°C/W
8-Lead SOIC		TBD		°C/W
8-Lead MSOP		TBD		°C/W
14-Lead SOIC		TBD		°C/W
14-Lead TSSOP		TBD		°C/W

Notes:

Package thermal resistance (θ_{JA}), JEDEC standard, multi-layer test boards, still air.

ESD Protection

Product	SC70-5	SOT23-5	SOIC-8	MSOP-8	SOIC-14	TSSOP-14
Human Body Model (HBM)	TBD	TBD	TBD	TBD	TBD	TBD
Charged Device Model (CDM)	TBD	TBD	TBD	TBD	TBD	TBD

Recommended Operating Conditions

Parameter	Min	Typ	Max	Unit
Operating Temperature Range	-40		+85	°C
Supply Voltage Range	2.5		5.5	V



Electrical Characteristics at +2.7V

$T_A = 25^\circ\text{C}$, $V_S = +2.7\text{V}$, $R_f = R_g = 5\text{k}\Omega$, $R_L = 10\text{k}\Omega$ to $V_S/2$, $G = 2$; unless otherwise noted.

Symbol	Parameter	Conditions	Min	Typ	Max	Units
Frequency Domain Response						
$UGBW_{SS}$	Unity Gain -3dB Bandwidth	$G = +1$, $V_{OUT} = 0.02V_{pp}$		4.9		MHz
BW_{SS}	-3dB Bandwidth	$G = +2$, $V_{OUT} = 0.2V_{pp}$		3.7		MHz
BW_{LS}	Large Signal Bandwidth	$G = +2$, $V_{OUT} = 2V_{pp}$		1.4		MHz
GBWP	Gain Bandwidth Product	$G = +11$, $V_{OUT} = 0.2V_{pp}$		2.2		MHz
Time Domain Response						
t_R , t_F	Rise and Fall Time	$V_{OUT} = 1\text{V}$ step; (10% to 90%)		163		ns
OS	Overshoot	$V_{OUT} = 1\text{V}$ step		<1		%
SR	Slew Rate	1V step		5.3		V/ μs
Distortion/Noise Response						
HD2	2nd Harmonic Distortion	$V_{OUT} = 1V_{pp}$, 10kHz		-72		dBc
HD3	3rd Harmonic Distortion	$V_{OUT} = 1V_{pp}$, 10kHz		-72		dBc
THD	Total Harmonic Distortion	$V_{OUT} = 1V_{pp}$, 10kHz		0.03		%
e_n	Input Voltage Noise	> 10kHz		21		nV/ $\sqrt{\text{Hz}}$
DC Performance						
V_{IO}	Input Offset Voltage ⁽¹⁾		-6	0.5	6	mV
dV_{IO}	Average Drift			5		$\mu\text{V}/^\circ\text{C}$
I_b	Input Bias Current ⁽¹⁾			90	420	nA
dI_b	Average Drift			32		pA/ $^\circ\text{C}$
PSRR	Power Supply Rejection Ratio ⁽¹⁾	DC	55	83		dB
A_{OL}	Open-Loop Gain	$V_{OUT} = V_S / 2$		90		dB
I_S	Supply Current ⁽¹⁾	per channel		136	190	μA
Input Characteristics						
R_{IN}	Input Resistance	Non-inverting		12		M Ω
C_{IN}	Input Capacitance			2		pF
CMIR	Common Mode Input Range			-0.25 to 2.95		V
CMRR	Common Mode Rejection Ratio ⁽¹⁾	DC	55	81		dB
Output Characteristics						
V_{OUT}	Output Voltage Swing	$R_L = 10\text{k}\Omega$ to $V_S / 2$ ⁽¹⁾	0.06 to 2.64	0.02 to 2.68		V
		$R_L = 1\text{k}\Omega$ to $V_S / 2$		0.05 to 2.63		V
		$R_L = 200\Omega$ to $V_S / 2$		0.11 to 2.52		V
I_{OUT}	Output Current			± 16		mA

Notes:

1. 100% tested at 25°C



Electrical Characteristics at +5V

$T_A = 25^\circ\text{C}$, $V_S = +5\text{V}$, $R_f = R_g = 5\text{k}\Omega$, $R_L = 10\text{k}\Omega$ to $V_S/2$, $G = 2$; unless otherwise noted.

Symbol	Parameter	Conditions	Min	Typ	Max	Units
Frequency Domain Response						
$UGBW_{SS}$	Unity Gain -3dB Bandwidth	$G = +1$, $V_{OUT} = 0.02V_{pp}$		4.3		MHz
BW_{SS}	-3dB Bandwidth	$G = +2$, $V_{OUT} = 0.2V_{pp}$		3.0		MHz
BW_{LS}	Large Signal Bandwidth	$G = +2$, $V_{OUT} = 2V_{pp}$		2.3		MHz
GBWP	Gain Bandwidth Product	$G = +11$, $V_{OUT} = 0.2V_{pp}$		2.0		MHz
Time Domain Response						
t_R, t_F	Rise and Fall Time	$V_{OUT} = 1\text{V}$ step; (10% to 90%)		110		ns
OS	Overshoot	$V_{OUT} = 1\text{V}$ step		<1		%
SR	Slew Rate	1V step		9		V/ μs
Distortion/Noise Response						
HD2	2nd Harmonic Distortion	$V_{OUT} = 1V_{pp}$, 10kHz		-73		dBc
HD3	3rd Harmonic Distortion	$V_{OUT} = 1V_{pp}$, 10kHz		-75		dBc
THD	Total Harmonic Distortion	$V_{OUT} = 1V_{pp}$, 10kHz		0.03		%
e_n	Input Voltage Noise	> 10kHz		22		nV/ $\sqrt{\text{Hz}}$
DC Performance						
V_{IO}	Input Offset Voltage ⁽¹⁾		-8	1.5	8	mV
dV_{IO}	Average Drift			15		$\mu\text{V}/^\circ\text{C}$
I_b	Input Bias Current ⁽¹⁾			90	450	nA
dI_b	Average Drift			40		pA/ $^\circ\text{C}$
PSRR	Power Supply Rejection Ratio ⁽¹⁾	DC	40	60		dB
A_{OL}	Open-Loop Gain	$V_{OUT} = V_S / 2$		80		dB
I_S	Supply Current ⁽¹⁾	per channel		160	235	μA
Input Characteristics						
R_{IN}	Input Resistance	Non-inverting		12		M Ω
C_{IN}	Input Capacitance			2		pF
CMIR	Common Mode Input Range			-0.25 to 5.25		V
CMRR	Common Mode Rejection Ratio ⁽¹⁾	DC	58	85		dB
Output Characteristics						
V_{OUT}	Output Voltage Swing	$R_L = 10\text{k}\Omega$ to $V_S / 2$ ⁽¹⁾	0.08 to 4.92	0.04 to 4.96		V
		$R_L = 1\text{k}\Omega$ to $V_S / 2$		0.07 to 4.9		V
		$R_L = 200\Omega$ to $V_S / 2$		0.14 to 4.67		V
I_{OUT}	Output Current			± 30		mA

Notes:

- 100% tested at 25°C

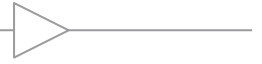

Typical Performance Characteristics

$T_A = 25^\circ\text{C}$, $V_S = +2.7\text{V}$, $R_f = R_g = 5\text{k}\Omega$, $R_L = 10\text{k}\Omega$ to $V_S/2$, $G = 2$; unless otherwise noted.

Non-Inverting Frequency Response at $V_S = 5\text{V}$

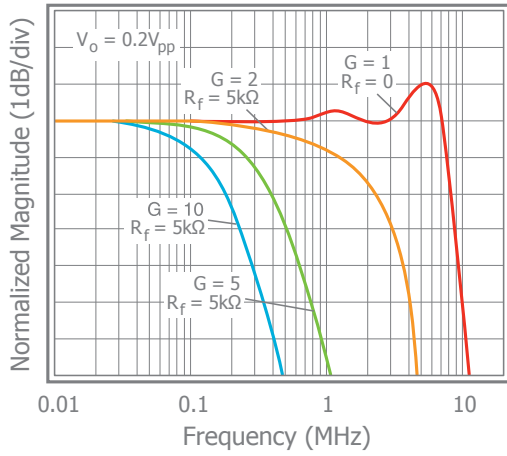

Inverting Frequency Response at $V_S = 5\text{V}$

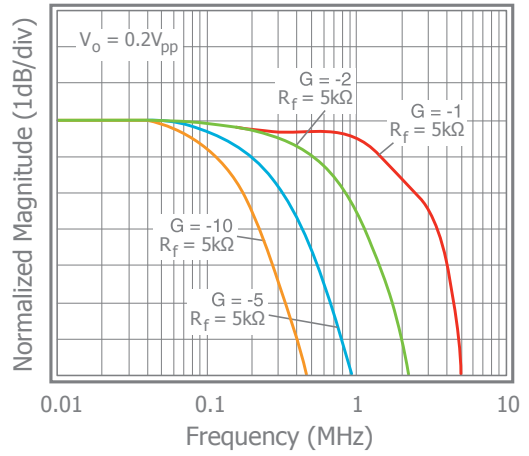

Non-Inverting Frequency Response

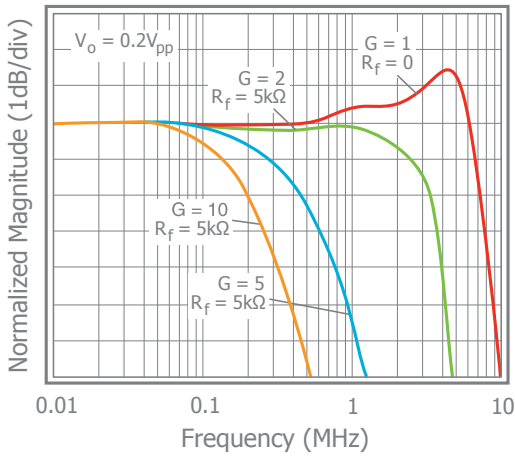

Inverting Frequency Response

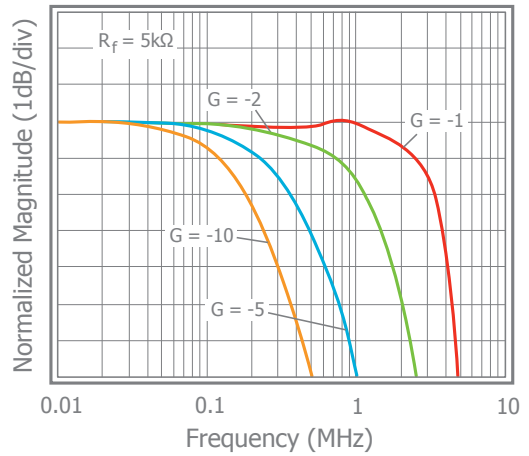

Frequency Response vs. C_L

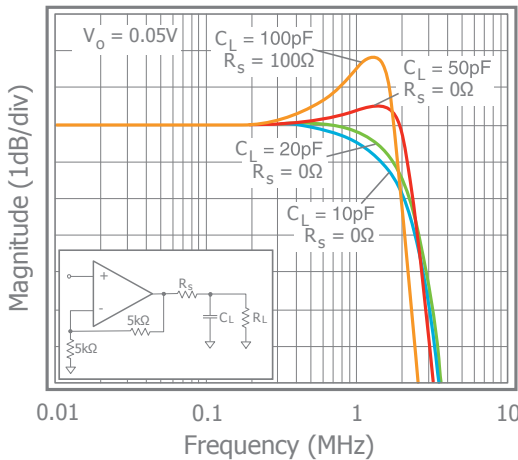

Frequency Response vs. R_L

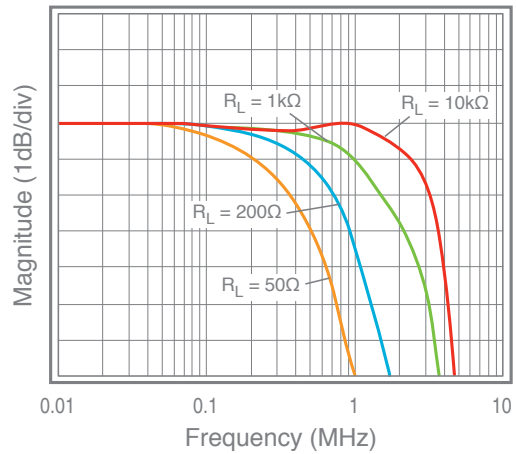



Typical Performance Characteristics

$T_A = 25^\circ\text{C}$, $V_S = +2.7\text{V}$, $R_f = R_g = 5\text{k}\Omega$, $R_L = 10\text{k}\Omega$ to $V_S/2$, $G = 2$; unless otherwise noted.

Frequency Response vs. V_{OUT}

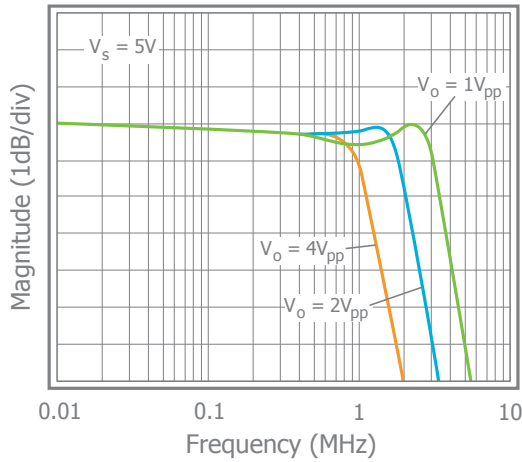

Open Loop Gain & Phase vs. Frequency

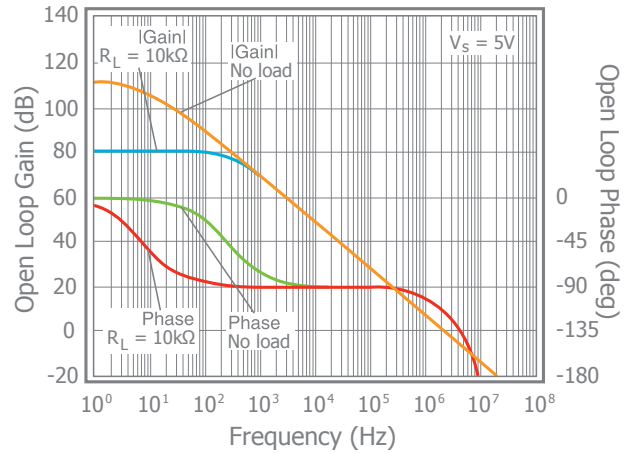

2nd Harmonic Distortion vs. V_{OUT}

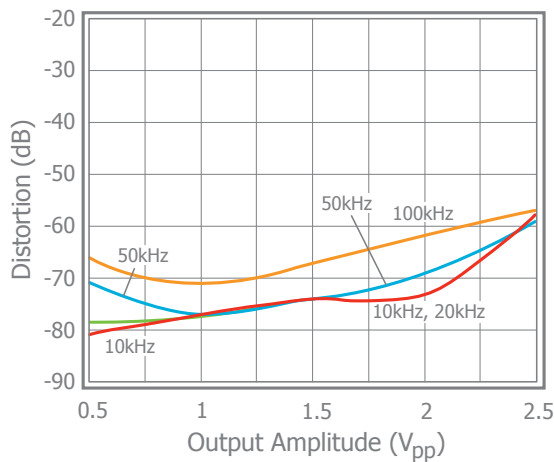

3rd Harmonic Distortion vs. V_{OUT}

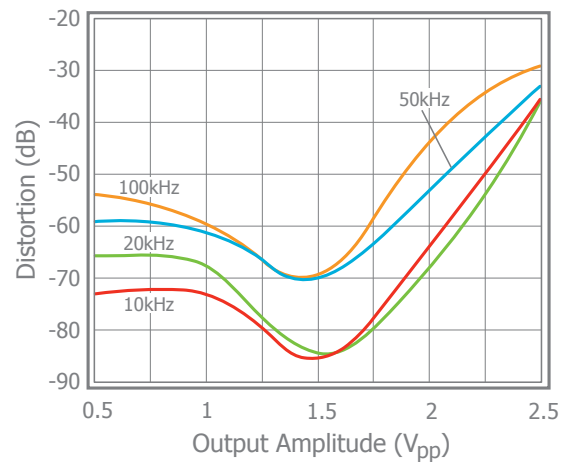

2nd & 3rd Harmonic Distortion

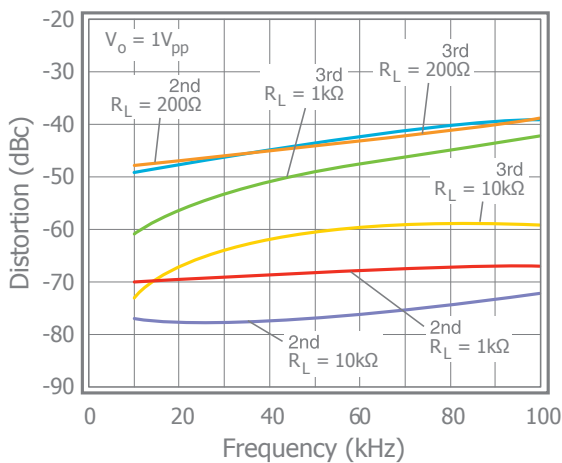

Input Voltage Noise

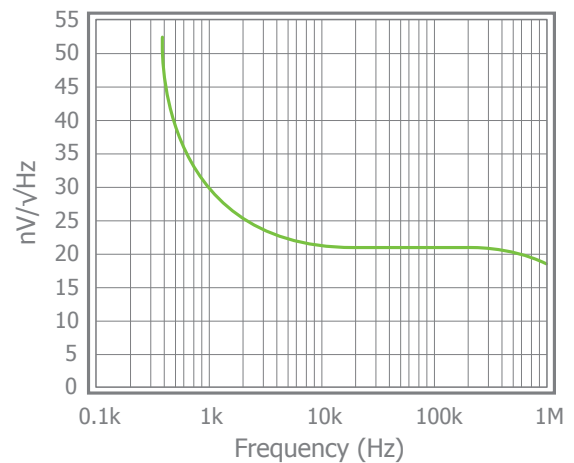

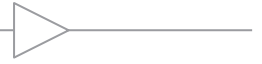

Typical Performance Characteristics - Continued

$T_A = 25^\circ\text{C}$, $V_S = \pm 5\text{V}$, $R_f = R_g = 150\Omega$, $R_L = 150\Omega$, $G = 2$; unless otherwise noted.

CMRR

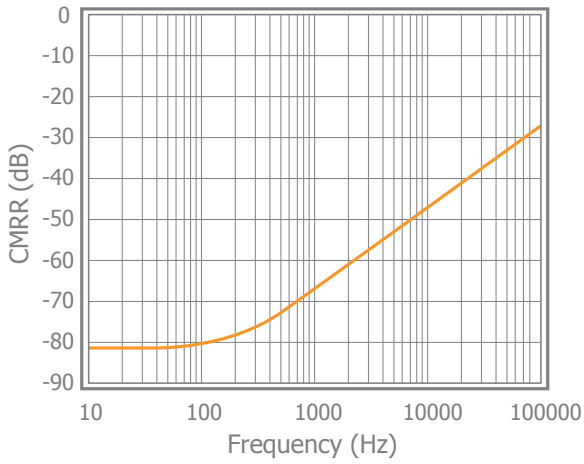

PSRR

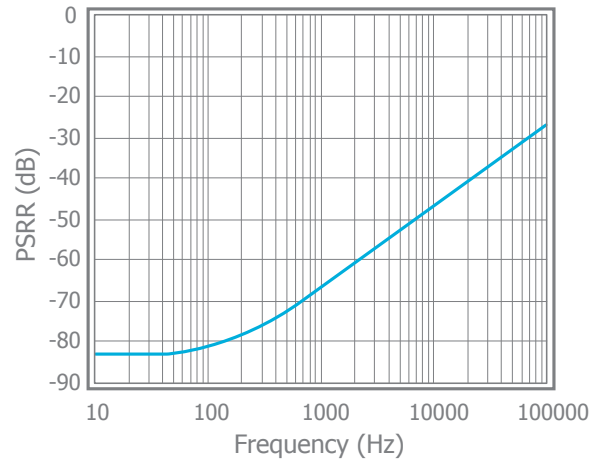

Output Swing vs. Load

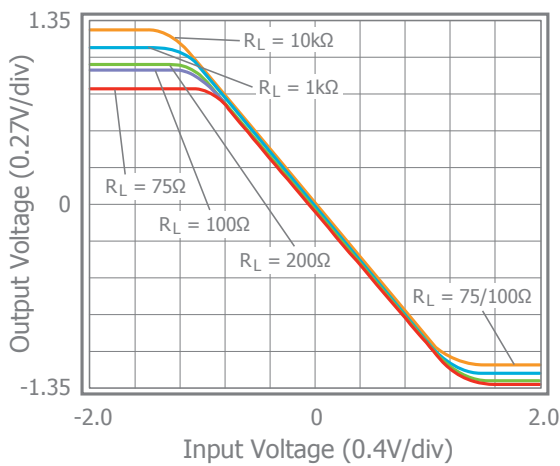

Pulse Response vs. Common Mode Voltage



Application Information

General Description

The CLCx011 family of amplifiers are single supply, general purpose, voltage-feedback amplifiers. They are fabricated on a complimentary bipolar process, feature a rail-to-rail input and output, and are unity gain stable.

Basic Operation

Figures 1, 2, and 3 illustrate typical circuit configurations for non-inverting, inverting, and unity gain topologies for dual supply applications. They show the recommended bypass capacitor values and overall closed loop gain equations.

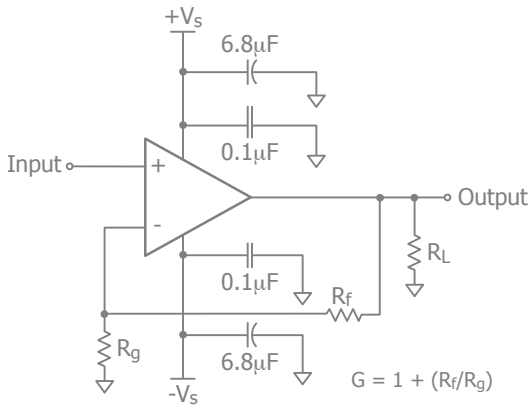

Figure 1. Typical Non-Inverting Gain Circuit

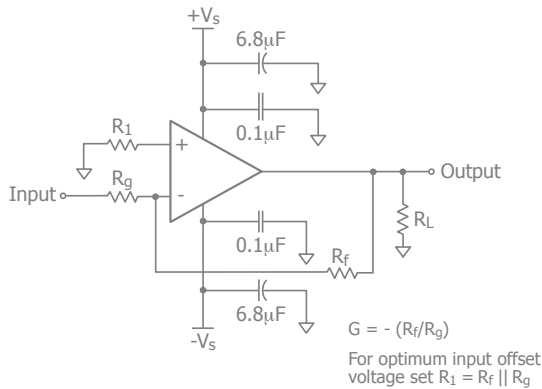

Figure 2. Typical Inverting Gain Circuit

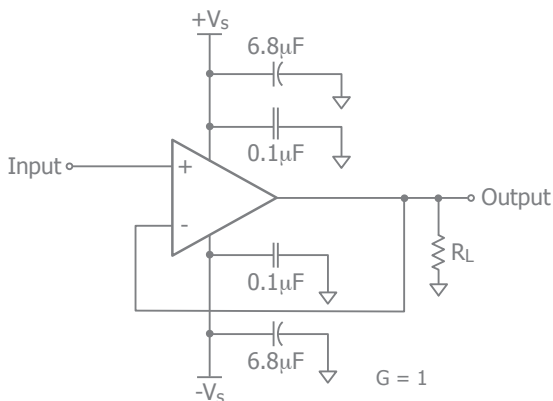

Figure 3. Unity Gain Circuit

Power Dissipation

Power dissipation should not be a factor when operating under the stated 10k ohm load condition. However, applications with low impedance, DC coupled loads should be analyzed to ensure that maximum allowed junction temperature is not exceeded. Guidelines listed below can be used to verify that the particular application will not cause the device to operate beyond its intended operating range.

Maximum power levels are set by the absolute maximum junction rating of 150°C. To calculate the junction temperature, the package thermal resistance value Θ_{JA} (Θ_{JA}) is used along with the total die power dissipation.

$$T_{Junction} = T_{Ambient} + (\Theta_{JA} \times P_D)$$

Where $T_{Ambient}$ is the temperature of the working environment.

In order to determine P_D , the power dissipated in the load needs to be subtracted from the total power delivered by the supplies.

$$P_D = P_{supply} - P_{load}$$

Supply power is calculated by the standard power equation.

$$P_{supply} = V_{supply} \times I_{RMS\ supply}$$

$$V_{supply} = V_{S+} - V_{S-}$$

Power delivered to a purely resistive load is:

$$P_{load} = ((V_{LOAD})_{RMS}^2) / R_{load\ eff}$$

The effective load resistor ($R_{load\ eff}$) will need to include the effect of the feedback network. For instance,

$R_{load\ eff}$ in figure 3 would be calculated as:

$$R_L \parallel (R_f + R_g)$$

These measurements are basic and are relatively easy to perform with standard lab equipment. For design purposes however, prior knowledge of actual signal levels and load impedance is needed to determine the dissipated power. Here, P_D can be found from

$$P_D = P_{Quiescent} + P_{Dynamic} - P_{Load}$$

Quiescent power can be derived from the specified I_S values along with known supply voltage, V_{Supply} . Load power can be calculated as above with the desired signal amplitudes using:

$$(V_{LOAD})_{RMS} = V_{PEAK} / \sqrt{2}$$

$$(I_{LOAD})_{RMS} = (V_{LOAD})_{RMS} / R_{load\ eff}$$

The dynamic power is focused primarily within the output stage driving the load. This value can be calculated as:

$$P_{DYNAMIC} = (V_{S+} - V_{LOAD})_{RMS} \times (I_{LOAD})_{RMS}$$

Assuming the load is referenced in the middle of the power rails or $V_{supply}/2$.

Figure 4 shows the maximum safe power dissipation in the package vs. the ambient temperature for the packages available.

Figure 4. Maximum Power Derating

Input Common Mode Voltage

The common mode input range extends to 250mV below ground and to 250mV above V_s , in single supply operation. Exceeding these values will not cause phase reversal. However, if the input voltage exceeds the rails by more than 0.5V, the input ESD devices will begin to conduct. The output will stay at the rail during this overdrive condition. If the absolute maximum input voltage (700mV beyond either rail) is exceeded, externally limit the input current to $\pm 5mA$ as shown in Figure 5.

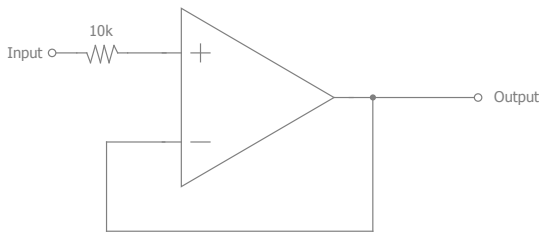

Figure 5. Circuit for Input Current Protection

Driving Capacitive Loads

Increased phase delay at the output due to capacitive loading can cause ringing, peaking in the frequency response,

and possible unstable behavior. Use a series resistance, R_S , between the amplifier and the load to help improve stability and settling performance. Refer to Figure 6.

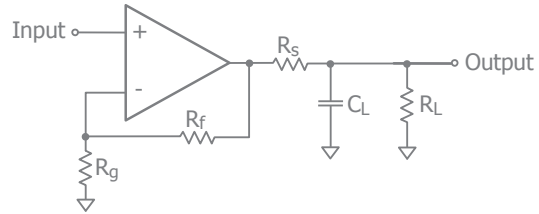

Figure 6. Addition of R_S for Driving Capacitive Loads

Table 1 provides the recommended R_S for various capacitive loads. The recommended R_S values result in approximately $<1dB$ peaking in the frequency response. The Frequency Response vs. C_L plot, on page 6, illustrates the response of the CLCx011.

C_L (pF)	R_S (Ω)	-3dB BW (kHz)
10pF	0	2.2
20pF	0	2.4
50pF	0	2.5
100pF	100	2

Table 1: Recommended R_S vs. C_L

For a given load capacitance, adjust R_S to optimize the tradeoff between settling time and bandwidth. In general, reducing R_S will increase bandwidth at the expense of additional overshoot and ringing.

Overdrive Recovery

An overdrive condition is defined as the point when either one of the inputs or the output exceed their specified voltage range. Overdrive recovery is the time needed for the amplifier to return to its normal or linear operating point. The recovery time varies, based on whether the input or output is overdriven and by how much the range is exceeded. The CLCx011 will typically recover in less than 50ns from an overdrive condition. Figure 7 shows the CLC1011 in an overdriven condition.



Evaluation Board Schematics

Evaluation board schematics and layouts are shown in Figures 8-14. These evaluation boards are built for dual-supply operation. Follow these steps to use the board in a single-supply application:

1. Short -Vs to ground.
2. Use C3 and C4, if the -Vs pin of the amplifier is not directly connected to the ground plane.

Figure 7. Overdrive Recovery

Layout Considerations

General layout and supply bypassing play major roles in high frequency performance. CADEKA has evaluation boards to use as a guide for high frequency layout and as an aid in device testing and characterization. Follow the steps below as a basis for high frequency layout:

- Include 6.8μF and 0.1μF ceramic capacitors for power supply decoupling
- Place the 6.8μF capacitor within 0.75 inches of the power pin
- Place the 0.1μF capacitor within 0.1 inches of the power pin
- Remove the ground plane under and around the part, especially near the input and output pins to reduce parasitic capacitance
- Minimize all trace lengths to reduce series inductances

Refer to the evaluation board layouts below for more information.

Evaluation Board Information

The following evaluation boards are available to aid in the testing and layout of these devices:

Evaluation Board	Products
CEB011	CLC1011 in SC70
CEB002	CLC1011 in SOT23
CEB006	CLC2011 in SOIC
CEB010	CLC2011 in MSOP
CEB018	CLC4011 in SOIC
CEB017	CLC4011 in TSSOP

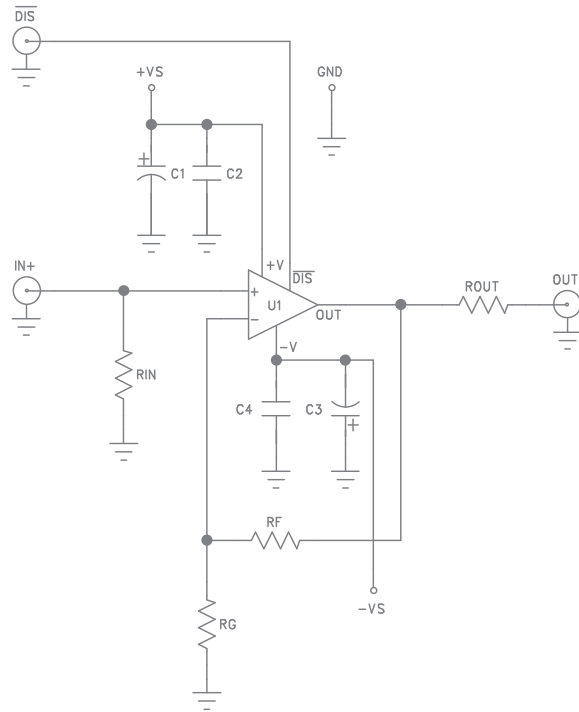

Figure 8. CEB002 Schematic

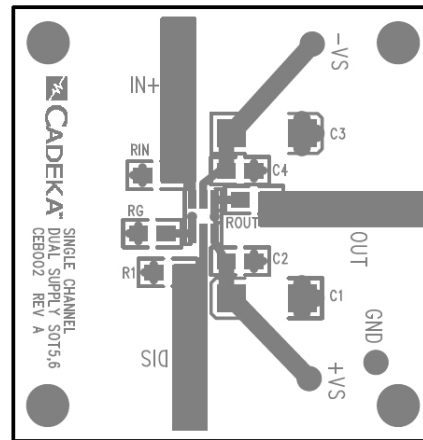

Figure 9. CEB002 Top View

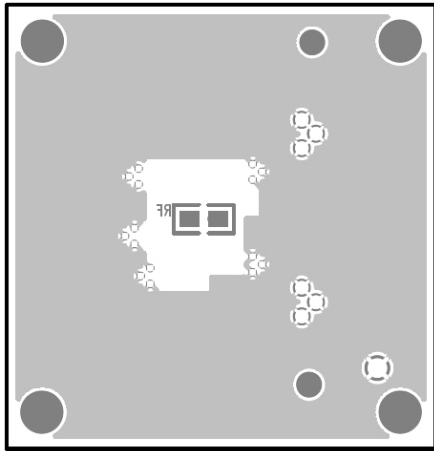

Figure 10. CEB002 Bottom View

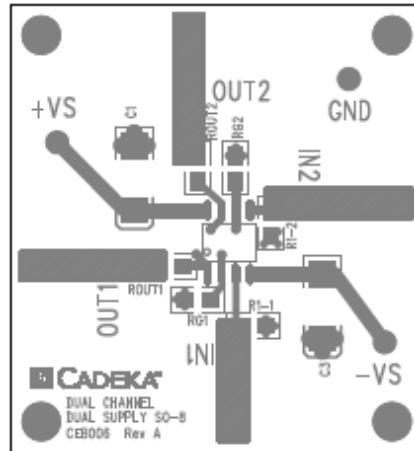

Figure 12. CEB006 Top View

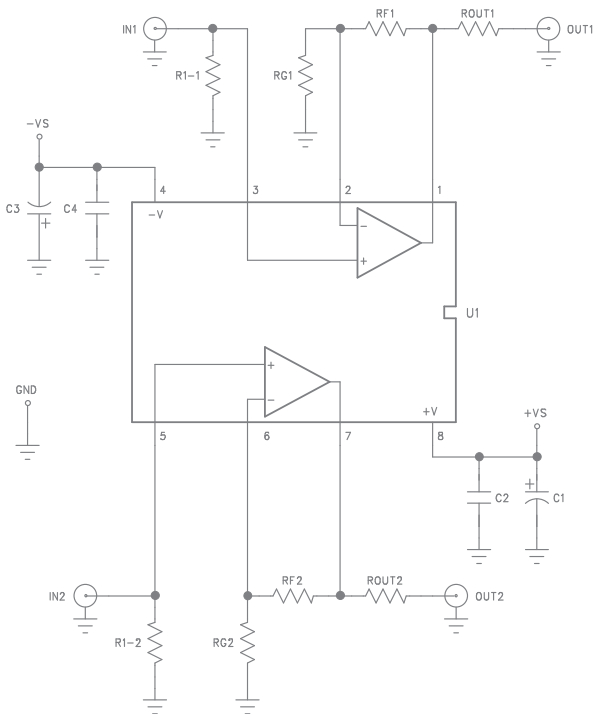

Figure 11. CEB006 Schematic

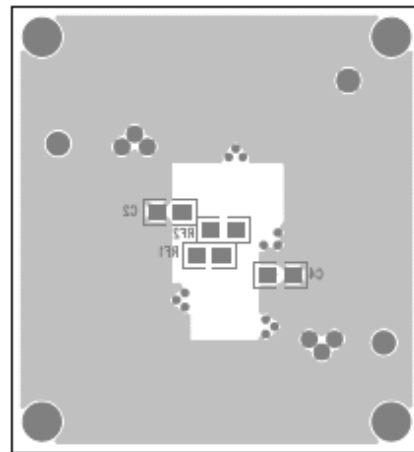

Figure 13. CEB006 Bottom View

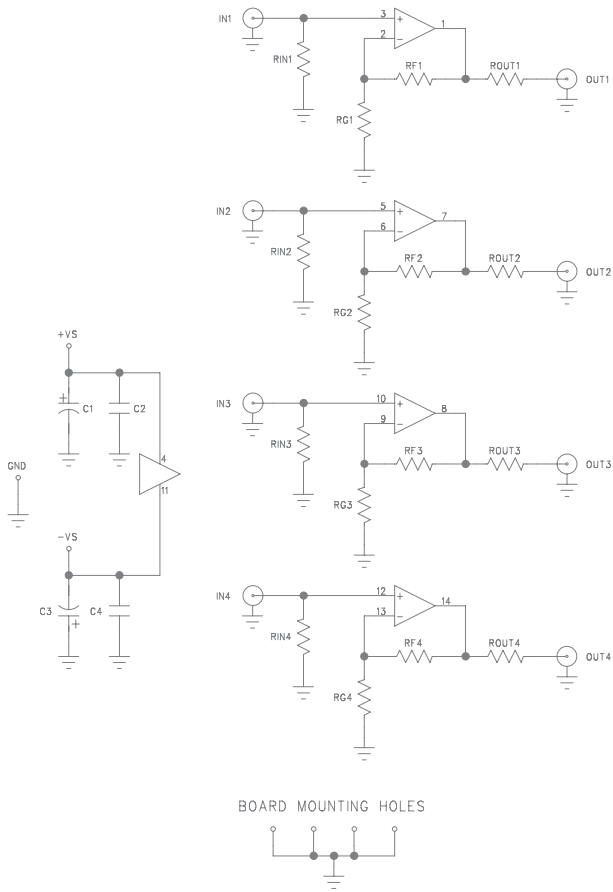
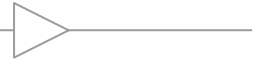

Figure 14. CEB018 Schematic

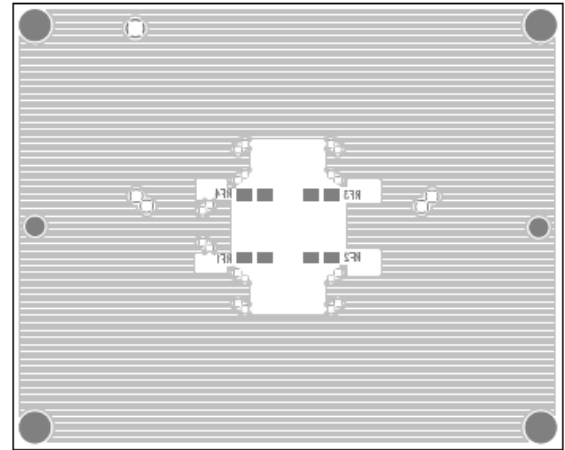

Figure 16. CEB018 Bottom View

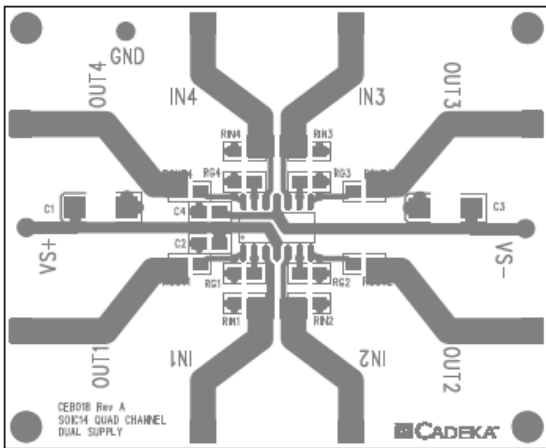
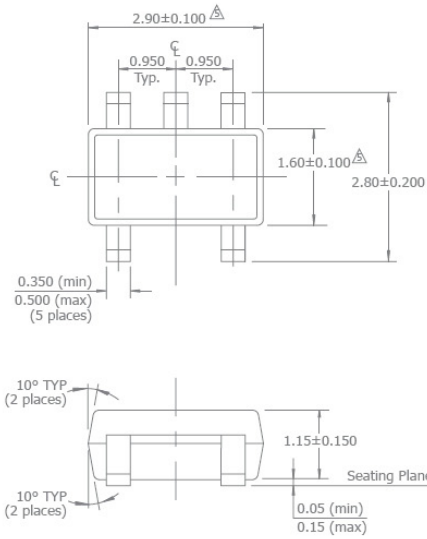

Figure 15. CEB018 Top View



Mechanical Dimensions

SOT23-5 Package



NOTES:

1. Dimensions and tolerances are as per ANSI Y14.5M-1982.
 2. Package surface to be matte finish VDI 11~13.
 3. Die is facing up for mold. Die is facing down for trim/form, ie. reverse trim/form.
 4. The footlength measuring is based on the gauge plane method.
- △ Dimension are exclusive of mold flash and gate burr.
 △ Dimension are exclusive of solder plating.

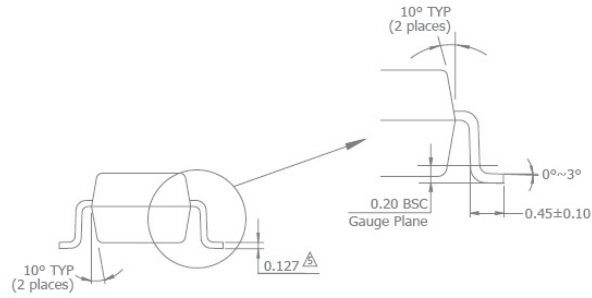

SOIC-8 Package

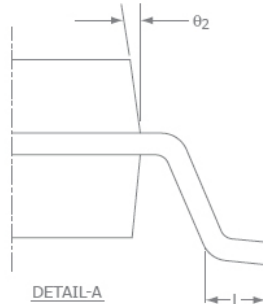
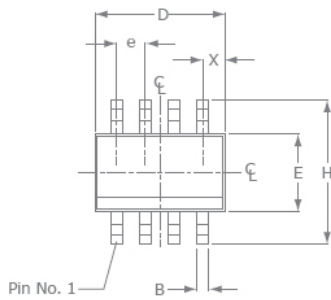

SOIC-8		
SYMBOL	MIN	MAX
A1	0.10	0.25
B	0.36	0.48
C	0.19	0.25
D	4.80	4.98
E	3.81	3.99
e	1.27 BSC	
H	5.80	6.20
h	0.25	0.5
L	0.41	1.27
A	1.37	1.73
θ ₁	0°	8°
X	0.55 ref	
θ ₂	7° BSC	

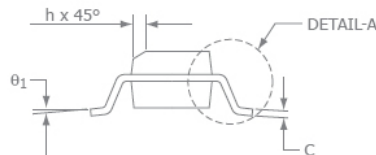
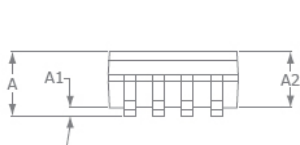

NOTE:

1. All dimensions are in millimeters.
2. Lead coplanarity should be 0 to 0.1mm (0.004") max.
3. Package surface finishing: VDI 24~27
4. All dimension excluding mold flashes.
5. The lead width, B to be determined at 0.1905mm from the lead tip.



Mechanical Dimensions continued

SOIC-14 Package

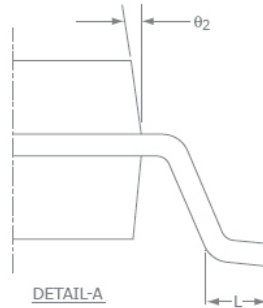
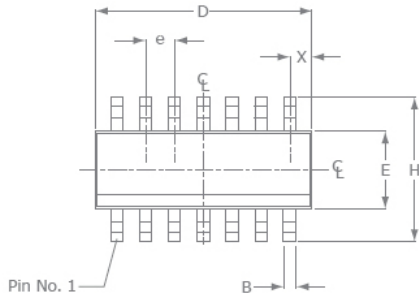

SOIC-14		
SYMBOL	MIN	MAX
A1	0.10	0.25
B	0.36	0.48
C	0.19	0.25
D	8.56	8.74
E	3.84	3.99
e	1.27 BSC	
H	5.80	6.20
h	0.25	0.5
L	0.41	1.27
A	1.37	1.73
θ_1	0°	8°
X	0.51 ref	
θ_2	7° BSC	

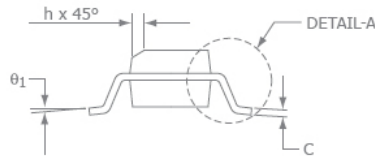
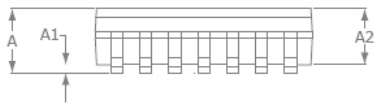

NOTE:

1. All dimensions are in millimeters.
2. Lead coplanarity should be 0 to 0.1mm (0.004") max
3. Package surface finishing: VDI 24~27
4. All dimension excluding mold flashes.
5. The lead width, B to be determined at 0.1905mm from the lead tip.

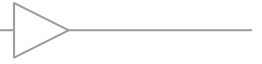

For additional information regarding our products, please visit CADEKA at: cadeka.com

CADEKA Headquarters Loveland, Colorado
T: 970.663.5452
T: 877.663.5452 (toll free)

CADEKA, the CADEKA logo design, COMLINEAR, the COMLINEAR logo design, and ARCTIC are trademarks or registered trademarks of CADEKA Microcircuits LLC. All other brand and product names may be trademarks of their respective companies.

CADEKA reserves the right to make changes to any products and services herein at any time without notice. CADEKA does not assume any responsibility or liability arising out of the application or use of any product or service described herein, except as expressly agreed to in writing by CADEKA; nor does the purchase, lease, or use of a product or service from CADEKA convey a license under any patent rights, copyrights, trademark rights, or any other of the intellectual property rights of CADEKA or of third parties.

Copyright ©2009 by CADEKA Microcircuits LLC. All rights reserved.

