

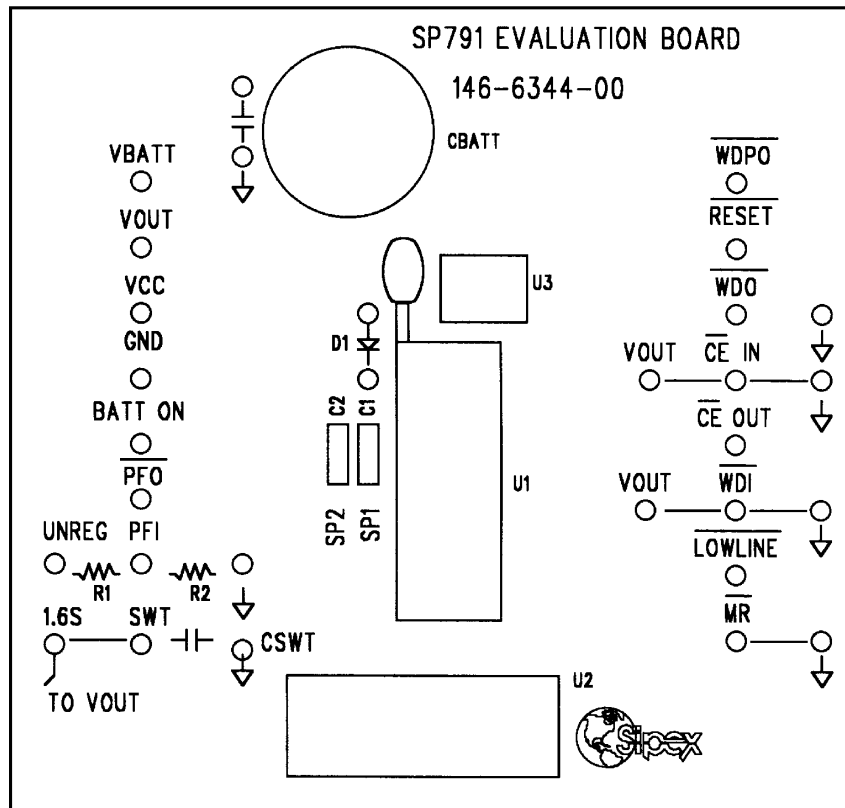

SP791 Evaluation Board Manual

- Easy Evaluation for the **SP791** Microprocessor Supervisory Circuit
- Probe Points Accessible for all **SP791** Pins
- 16 Pin Narrow SOIC or DIP Sockets Available for the **SP791** Circuit
- Convenient Layout of Input Option Probe Points



DESCRIPTION...

The **SP791 Evaluation Board** is designed to help analyze the many functions of the **SP791** μ P Supervisory circuit. The evaluation board provides easy probe access points to all **SP791** pins so that the user can measure electrical characteristics and waveforms of each signal. **The SP791 Evaluation Board** also provides solder pads for DIP or SOIC packages, as well as options for DIP or SOIC sockets for easy evaluation of multiple devices.

The next two sections describe the **SP791** Board Layout and Using the **SP791** Evaluation Boards. A table of **SP791** Pin Assignments is also included with a section on Power Supply Connections. A **SP791 Evaluation Board** List of Materials is provided with some manufacturers part numbers to use as a reference. Finally, a schematic is included of the **SP791 Evaluation Board**.

BOARD LAYOUT

The **SP791 Evaluation Board** has been designed to easily and conveniently provide access to all pins of the **SP791** device under test. Position the board with the silkscreen lettering upright (also see drawing on the front page of this manual) and you will see two vertical rows of eight pins each, which represent the 16 pins of the **SP791** device starting in the top left with V_{BATT} as pin one. The pin receptacles are raised female pins which can accommodate easy-hook connection leads for power and meter connections, as well as scope probe hooks and grounds for waveform measurements.

The 16 pin **SP791** may be installed in one of 3 locations: U1 for DIP or DIP sockets, U3 for SOICs or U2 for SOIC sockets. The five input pins for the **SP791** are provided with extra Input Probe Points for connecting inputs to these pins. For example pin 11 WDI has nearby pins V_{OUT} and GND to connect to for evaluation of WDI timeout. These female receptacle pins can be jumpered together with easy-hook connectors or stripped back solid wire leads. In the case of inputs SWT or PFI, a resistor or capacitor with leads may be pushed into the female receptacle pins to make easy connections. Also, mating male pins (see List of Materials) may be soldered to the components and inserted into the receptacle pins.

USING THE EVALUATION BOARD

Connect the **SP791 Evaluation Board** to the power supplies for V_{CC} and V_{BATT} (see the section Power Supply Connections following the table **SP791 Pin Assignments**). It is good practice to not switch power on until power connections are made to the evaluation board.

Evaluating Pin Functions

Pin 1 - V_{BATT} - Backup-Battery Input. Connect to external supply, battery or capacitor and charging circuit.

Pin 2 - V_{OUT} - Output Supply Voltage. This function is used to provide power supply switching of either V_{CC} or V_{BATT} to an external device like a CMOS RAM to ensure a constant supply for the memory. To evaluate this function, vary the V_{CC} voltage for a set V_{BATT} voltage until you simulate the following conditions: V_{OUT} connects to V_{CC} when V_{CC}

is greater than V_{BATT} and V_{CC} is above the reset threshold. When V_{CC} falls below V_{BATT} and V_{CC} is below the reset threshold, V_{OUT} connects to V_{BATT} . Start with V_{BATT} voltage of about 2.8 to 4.0 V and vary V_{CC} from 0V to 5V to 0V and observe V_{OUT} . (Note: a 0.1 μ F bypass capacitor (C1) is connected from V_{OUT} to GND).

Pin 3 - V_{CC} - Input Supply Voltage - +5V input. A 0.1 μ F bypass capacitor (C2) is connected from V_{CC} to GND.

Pin 4 - GND - Ground reference for all signals.

Pin - 5 - BATT ON - Battery On Output. Goes high when V_{OUT} switches to V_{BATT} . Goes low when V_{OUT} switches to V_{CC} . Connect the base of a PNP through a current-limiting resistor to BATT ON for V_{OUT} current requirements greater than 250mA.

Pin 6 - PFO - Power-Fail Output. This is the output of the power-fail comparator. PFO, goes low when PFI is less than 1.25V. This is an uncommitted comparator, and has no effect on any other internal circuitry.

Pin 7 - PFI - Power-Fail Input. This is the non-inverting input to the power-fail comparator. When PFI is less than 1.25V, PFO goes low. Connect PFI to GND or V_{OUT} when not used. Connect external divider R1 & R2 to Probe Pins and connect Unregulated Voltage to UNREG for Power Fail monitoring.

Pin 8 - SWT - Set Watchdog-Timeout Input. Connect this input to V_{OUT} to select the default 1.6 sec watchdog timeout period. Connect a capacitor (C_{SWT}) between the Probe Input Pins SWT and GND to select another watchdog-timeout period. Watchdog-timeout period = 2.1 x (capacitor value in nF) ms.

Pin 9 - MR - Manual-Reset Input. This input can be tied to an external momentary pushbutton switch, or to a logic gate output. RESET remains low as long as MR is held Low and for 200ms after MR returns high. Connect MR to Probe Pin GND to cause a RESET active low.

Pin 10 - LOWLINE - LOWLINE Output goes low when V_{CC} falls to 150mV above the reset threshold. The output can be used to generate a NMI (non-maskable interrupt) if the unregulated supply is inaccessible

Pin 11 - WDI - Watchdog Input. WDI is a three-level input. If WDI remains either high or low for longer than the watchdog timeout period, WDO goes low. WDO remains low until the next transition at WDI. Leaving WDI unconnected disables the watchdog function. WDI connects to an internal voltage divider between V_{OUT} and GND, which sets it to 1.8V when left unconnected. For a simple check of watchdog function, connect WDI to either Probe pins GND or V_{OUT} to cause WDO to go to a Logic Low and produce pulses at WDPO every 1.6 seconds. (typically 1.6 seconds unless an external capacitor is used at the SWT pin).

Pin 12 - CE OUT - Chip-Enable Output. The Chip-Enable (CE) function CE OUT provides internal gating of chip enable signals to prevent erroneous data from corrupting the CMOS RAM in the event of a power failure. During normal operation, the CE gate is enabled and all CE transitions are passed from CE IN to CE OUT. When Reset is asserted, this path is disabled. Note that CE OUT goes low (active) only when CE IN is low and V_{CC} is above the reset threshold. If CE IN is low when reset is asserted, CE OUT will stay low for 15us or until CE IN goes high, whichever occurs first.

Pin 13 - CE IN - Chip-Enable Input. The Input to chip-enable gating circuit. Connect to GND or V_{OUT} if not used.

Pin 14 - WDO - Watchdog Output. WDO goes low if WDI remains either high or low longer than the watchdog timeout period. WDO returns high on the next transition at WDI. WDO remains high if WDI is unconnected. WDO is also high when RESET is asserted.

Pin 15 - RESET - RESET Output goes low whenever V_{CC} falls below the reset threshold. RESET will remain low for 200ms after V_{CC} crosses the reset threshold on power-up.

Pin 16 - WDPO - Watchdog-Pulse Output. Upon the absence of a transition at WDI, WDPO will pulse low for 1ms. WDPO precedes WDO by 70ns.

Note: To accurately measure the extremely small supply current in Battery Back-up mode, you need to cut split pads SP1 & SP2 (solder side of board) severing connections to C1 & C2 which would have leakage currents in the measurement range. Also, remove charging circuit components C_{BATT} and D1 if they are installed.

SP791 Pin Assignments

SP791 Pin Assignments				
Pin No.	Pin Name	Pin Function	ActiveLevel	Input Pin Points
1	V_{BATT}	Backup-Battery Input	NA	
2	V_{OUT}	Output Supply Voltage	NA	
3	V_{CC}	Input Supply Voltage	NA	
4	GND	Ground for all Signals	NA	
5	BATT ON	Battery On Output	HIGH	
6	PFO	Power-Fail Output	LOW	
7	PFI	Power-Fail Input	HIGH	R1 & R2
8	SWT	Set Watchdog-Timeout Input	NA	1.6S or C_{SWT}
9	MR	Manual-Reset Input	LOW	GND
10	LOWLINE	Lowline Output	LOW	
11	WDI	Watchdog Input	Transitions	V_{OUT} & GND
12	CE OUT	Chip-Enable Output	LOW	
13	CE IN	Chip-Enable Input	LOW	V_{OUT} & GND
14	WDO	Watchdog Output	LOW	
15	RESET	Reset Output	LOW	
16	WDPO	Watchdog-Pulse Output	LOW	

Power Supply Connections

Pin 3 — V_{CC} — connect to external +5 VDC supply.

Pin 1 — V_{BATT} — connect to external V+ supply of 2.8 to 4.0 VDC, or install capacitor C_{BATT} and charging diode D1 (see List of Materials).

Pin 4 — GND — connect to negative or ground of +5VDC supply and ground of V+ supply for V_{BATT}

Note: Ensure V_{CC} , V_{BATT} and GND connections are made before operating device.

SP791 Evaluation Board List of Materials

Component	Part Number	Manufacturer	Ref. Des.	Quantity
uP Supervisor IC	SP791	Sipex	U3	1
Pin Receptacle-Female	300-1150-1472-7040	Mill-Max Mfg.		26
Ceramic Capacitor 0.1uF		Generic	C1, 2	2
Al. Spacers - 0.5"	8414	Keystone Elec.		4
6-32 Hex Nut		Generic		4
Optional:				
16 Pin DIP Socket	216-3340-00-0602	3M - Textool	U1	1
16 Pin SOIC Socket	216-7383-55-1902	3M - Textool	U2	1
Maxcap 1F 5.5V	LC055105A	Cesiwid Inc.	C_{BATT}	1
Signal Diode		Generic	D1	1
Pin Receptacle - Male	3137-3002-10-0080	Mill-Max Mfg.		26

SP791 Evaluation Board Schematic

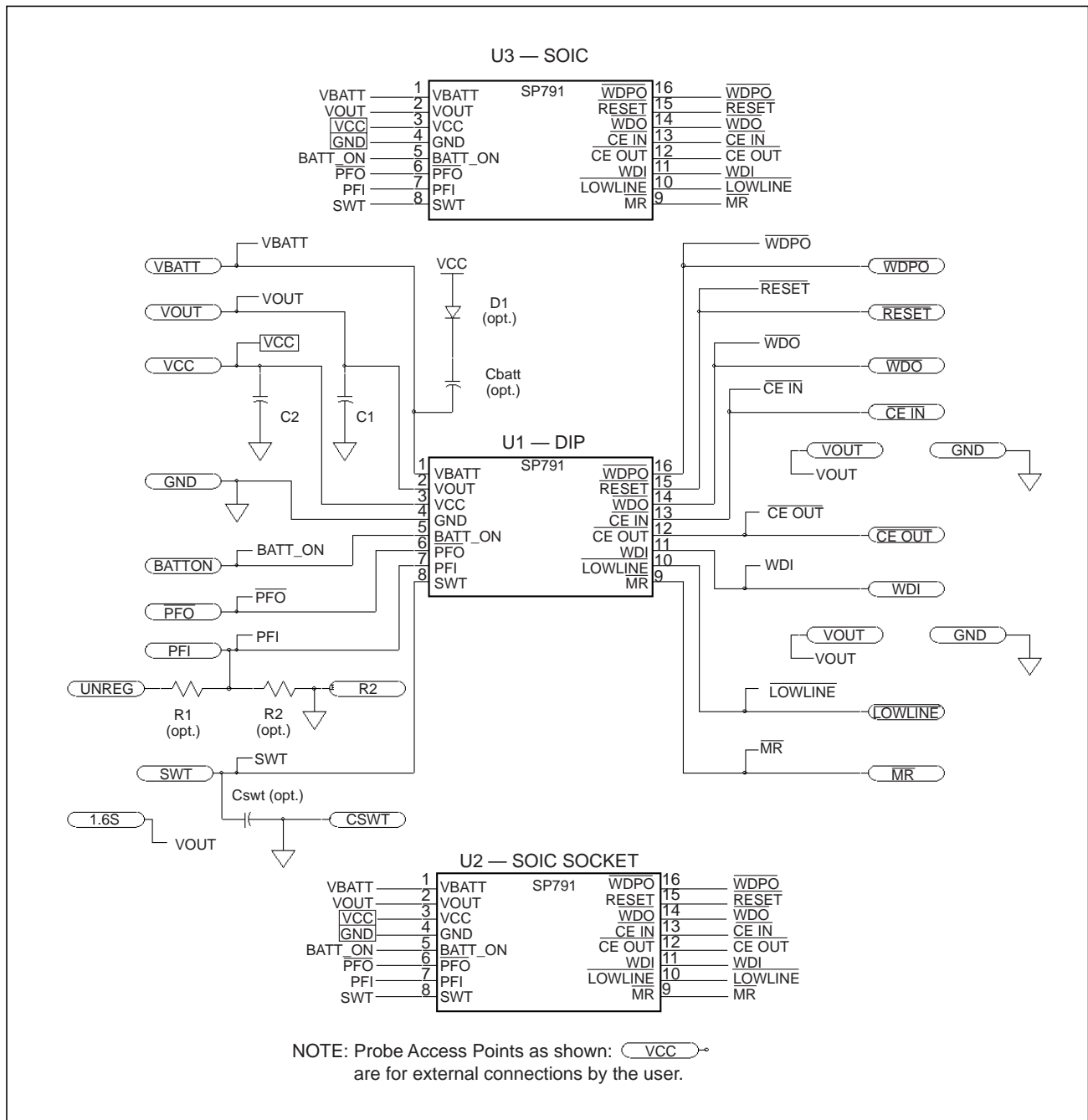

ORDERING INFORMATION

Model	Package
SP791EB	SP791 Evaluation Board
SP791EK	SP791 Evaluation Kit



SIGNAL PROCESSING EXCELLENCE

Sipex Corporation

Headquarters and Sales Office

22 Linnell Circle
Billerica, MA 01821
TEL: (978) 667-8700
FAX: (978) 670-9001
e-mail: sales@sipex.com

Sales Office

233 South Hillview Drive
Milpitas, CA 95035
TEL: (408) 934-7500
FAX: (408) 935-7600

Sipex Corporation reserves the right to make changes to any products described herein. Sipex does not assume any liability arising out of the application or use of any product or circuit described hereing; neither does it convey any license under its patent rights nor the rights of others.