

Microprocessor Supervisory Circuit with Pull Up Resistor

FEATURES

- Holds Microcontroller in Reset
- Reset Microcontroller during power loss
- 4.375 and 3.075 Voltage Trip Points
- Active Low $\overline{\text{RESET}}$ Pin
- Internal Pull-up Resistor
- Holds $\overline{\text{RESET}}$ for 350ms (typical)
- $\overline{\text{RESET}}$ valid down to $V_{\text{DD}} 1.0\text{V}$
- 45 μA Typical Operating Current
- Offered in a 3 Pin SOT-23 Package

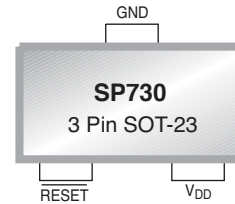

Now Available in Lead Free Packaging

APPLICATIONS

- Portable Electronic Devices
- Electrical Power Meter
- Computer System Board
- Modem

DESCRIPTION

The SP730 is a voltage supervisory device designed to keep a microcontroller in reset until the system voltage has reached the proper level and stabilized. It also operates as protection from brown-out conditions when the supply voltage drops below a safe operating level. The SP730 has an internal 5k Ω pull-up resistor. The device has an active low $\overline{\text{RESET}}$ pin and will assert the $\overline{\text{RESET}}$ signal whenever the voltage on the V_{DD} pin is below the trip-point voltage. The part is available in a small 3 pin SOT-23 package. Contact factory for other trip voltage options.

TYPICAL APPLICATION CIRCUIT

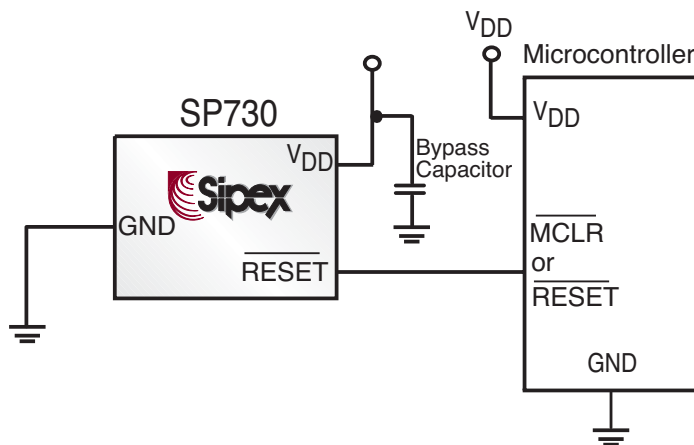

ABSOLUTE MAXIMUM RATINGS

V_{DD}	6.0V
All inputs and outputs w.r.t. GND	-0.6 to $V_{DD} + 1.0V$
Storage Temperature	-65°C to +150°C
Ambient Temperature with power applied.....	-65°C to +125°C
ESD Protection on all pins	$\geq 2kV$

These are stress ratings only and functional operation of the device at these ratings or any other above those indicated in the operation sections of the specifications below is not implied. Exposure to absolute maximum rating conditions for extended periods of time may affect reliability.

ELECTRICAL CHARACTERISTICS

$V_{DD} = 1.0V - 5.5V$; -40°C to 85°C. The ♦ denotes the specifications which apply over the full operating temperature range, unless otherwise specified.

Parameter	Symbol	Min.	Typ.	Max.		Units	Conditions
Operating Voltage Range	V_{DD}	1.0		5.5	♦	V	
V_{DD} Value to $\overline{\text{RESET}}$	V_{DDMIN}	1.0			♦	V	
Operating Current	I_{DD}		45	60	♦	μA	$V_{DD} = 5.5V$ (no load)
V_{DD} Trip Point	V_{TRIP}	3.0	3.075	3.15	♦	V	
		4.25	4.375	4.50	♦		
Threshold Hysteresis	V_{HYS}		50		♦	mV	
$\overline{\text{RESET}}$ Low Level Output Voltage	V_{OL}			0.6	♦	V	$I_{OL} = 8.5mA$, $V_{DD} = V_{TRIP MIN}$
$\overline{\text{RESET}}$ High Level Output Voltage	V_{OH}	$V_{DD} - .7$			♦	V	$I_{OH} = 50\mu A$, $V_{DD} > V_{TRIP MAX}$
Pull up Resistor			5		♦	K Ω	
V_{DD} Detect to $\overline{\text{RESET}}$ Inactive	t_{RPU}	150	350	700	♦	ms	
V_{DD} Detect to $\overline{\text{RESET}}$	t_{RPD}		10		♦	μS	V_{DD} ramped from $V_{TRIP MAX}$ ($V_{TRIP MAX} + 250mV$) to ($V_{TRIP MIN} - 250mV$)

PIN DESCRIPTION

PIN NUMBER	PIN NAME	3 PIN SOT-23 DESCRIPTION
1	$\overline{\text{RESET}}$	Active Low. This pin goes low whenever V_{DD} falls below the reset threshold.
2	V_{DD}	Supply input.
3	GND	Ground.

FUNCTIONAL DIAGRAM

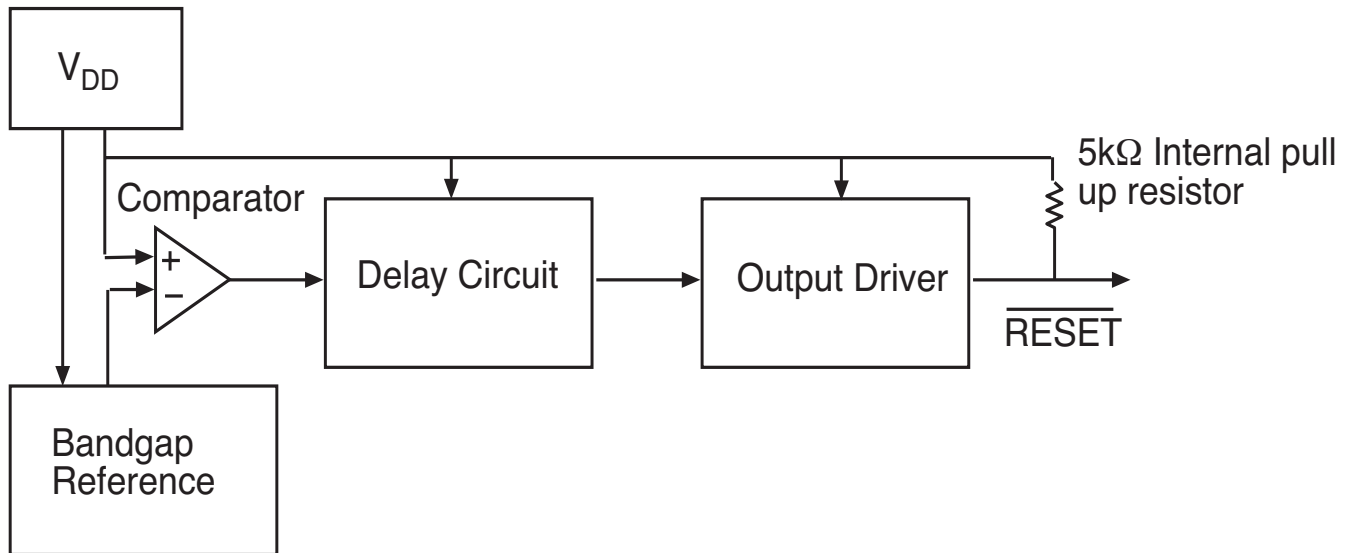

TIMING DIAGRAM

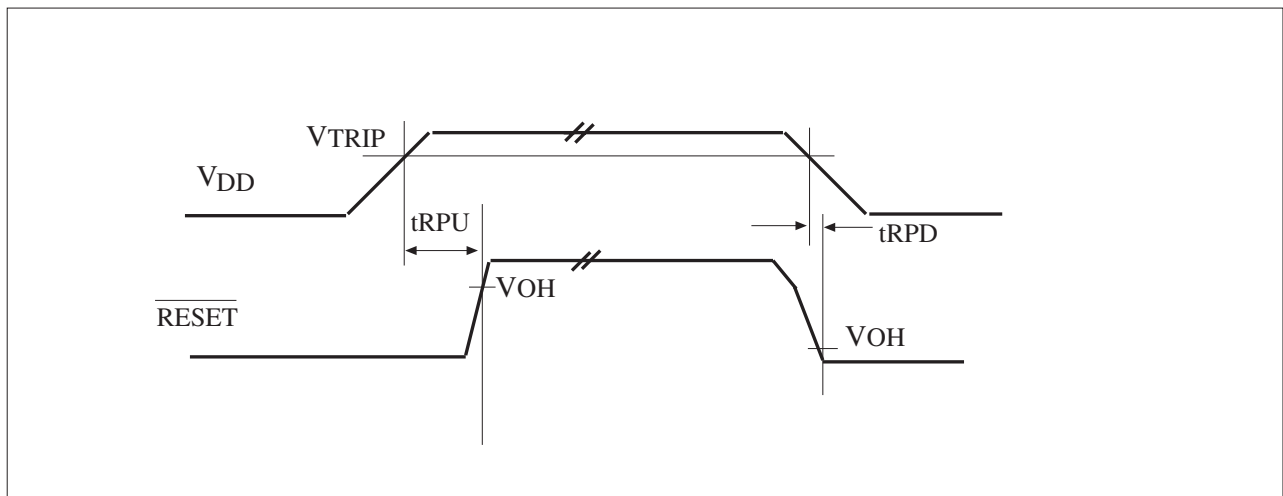
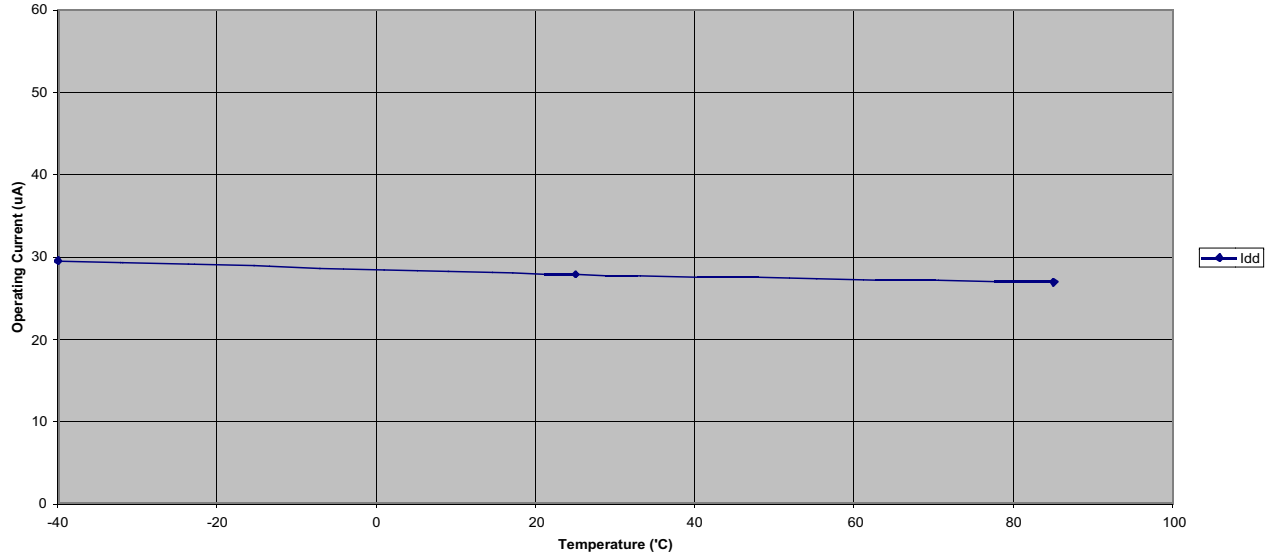

Figure 1: SP730 Timing Diagram

TYPICAL PERFORMANCE CHARACTERISTICS

I_{dd} vs Temperature



tRPU vs Temperature

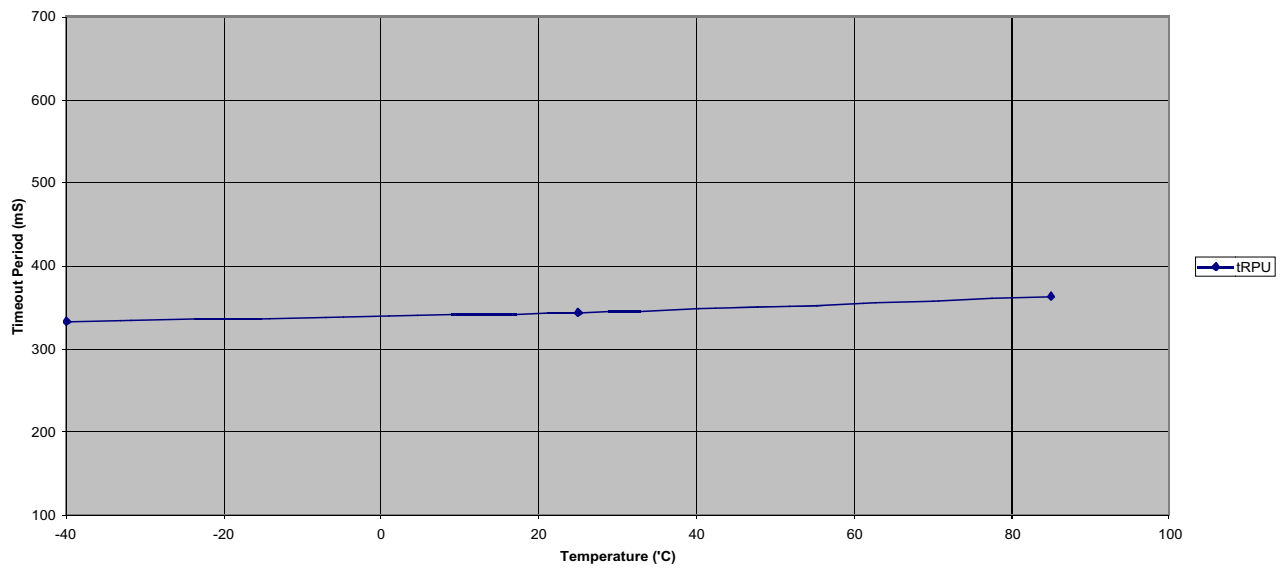

TYPICAL PERFORMANCE CHARACTERISTICS

Normalized VTRIP vs Temperature

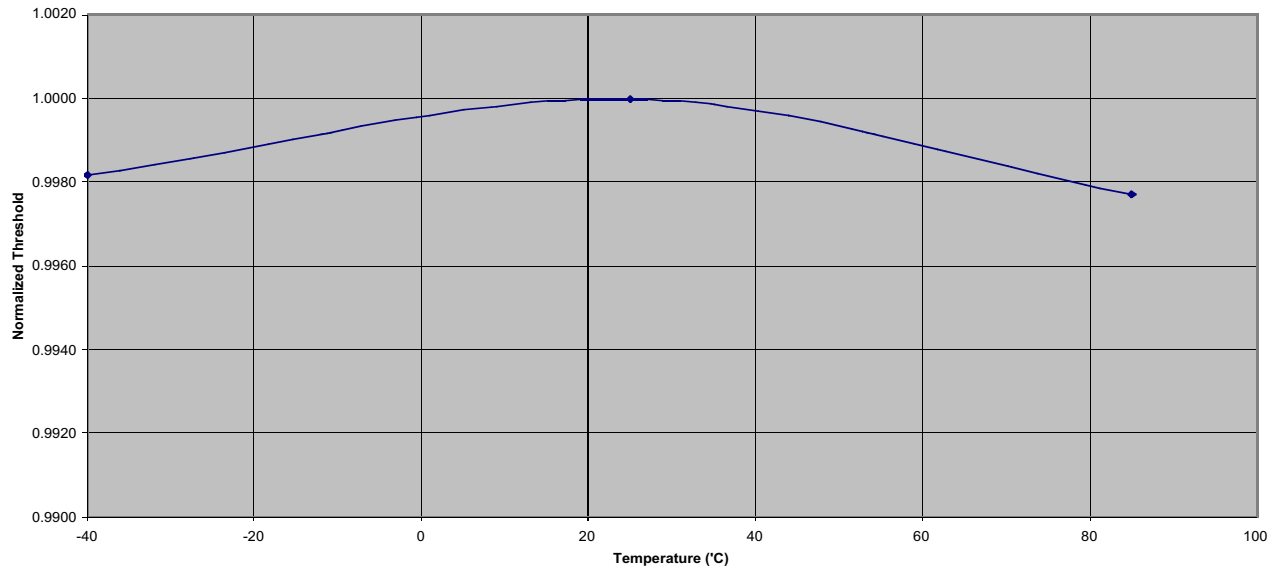

VOL vs IOL

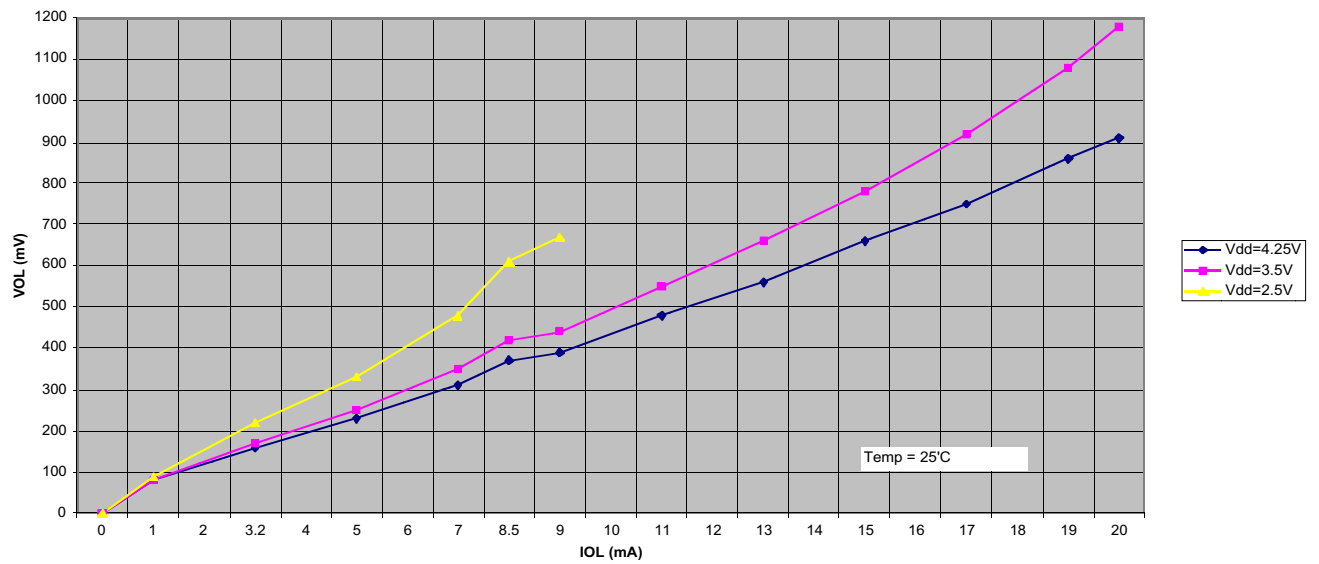

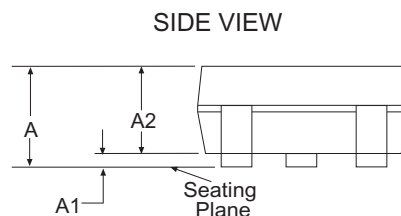
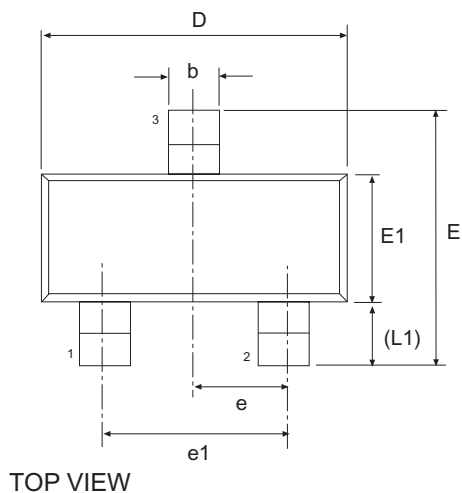

FRONT VIEW

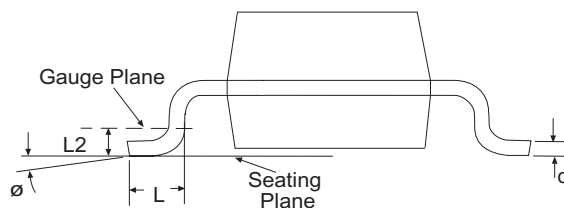

3 Pin SOT-23		JEDEC TO-236		Variation AB		
SYMBOL	Dimensions in Millimeters: Controlling Dimension			Dimensions in Inches Conversion Factor: 1 Inch = 25.40 mm		
	MIN	NOM	MAX	MIN	NOM	MAX
b	0.30	-	0.50	0.012	-	0.020
c	0.08	-	0.20	0.003	-	0.008
D	2.80	2.90	3.04	0.110	0.114	0.120
E	2.10	-	2.64	0.083	-	0.104
E1	1.20	1.30	1.40	0.047	0.051	0.055
e	0.95 BSC			0.038 BSC		
e1	1.90 BSC			0.075 BSC		
L	0.40	0.50	0.60	0.016	0.020	0.024
L1	0.54 REF			0.021 REF		
L2	0.25 BSC			0.010 BSC		
∅	0°	-	8°	0°	-	8°
A	0.89	-	1.12	0.035	-	0.044
A1	0.01	-	0.10	0.000	-	0.004
A2	0.88	0.95	1.02	0.035	0.037	0.040
SIPEX Pkg Signoff Date/Rev:				JL Oct25-05 / Rev A		

ORDERING INFORMATION

Part number	Top Mark	Temperature	Vout	Package
SP730EK-4-375.....	V3WW.....	-40°-85°.....	4.375V.....	3 Pin SOT-23
SP730EK-4-375/TR.....	V3WW.....	-40°-85°.....	4.375V.....	3 Pin SOT-23
SP730EK-3-075.....	M4WW.....	-40°-85°.....	3.075V.....	3 Pin SOT-23
SP730EK-3-075/TR.....	M4WW.....	-40°-85°.....	3.075V.....	3 Pin SOT-23

Contact factory for other trip voltage options.

Available in lead free packaging. To order add "-L" suffix to part number.

Example: SP730EK-4-375/TR = standard; SP730EK-L-4-375/TR = lead free

/TR = Tape and Reel

Pack quantity is 2500 for SOT-23.



Solved By Sipex™

Sipex Corporation

**Headquarters and
Sales Office**

233 South Hillview Drive
Milpitas, CA 95035
TEL: (408) 934-7500
FAX: (408) 935-7600