

STR-F6600 Series



SanKen

SMPS PRIMARY IC

Advantages

- Greatly Reduced Part Count
- Rugged Avalanche Rated MOSFET
- Choice of MOSFET Voltage and $R_{ds(on)}$
- Flyback Operation with Quasi-Resonant Soft Switching for Low Dissipation & EMI
- Full Overcurrent Protection (no blanking)
- Undervoltage Lock-out with Hysteresis
- Overvoltage Protection
- Direct Voltage Feedback
- Low Start-up current, <math><400\mu A</math>
- Low Frequency Low power Standby Operation
- Rugged Isolated 5 pin Package

The STR-F6600 series from Allegro/Sanken is a range of low cost, offline hybrid IC regulators covering applications from 20 to 300 watt.

This flexibility is achieved by offering a choice of MOSFET $R_{ds(on)}$ and V_{ce} ratings. A very high performance regulator and MOSFET, together with internal trimming, keep external parts count very low without compromising regulator performance.

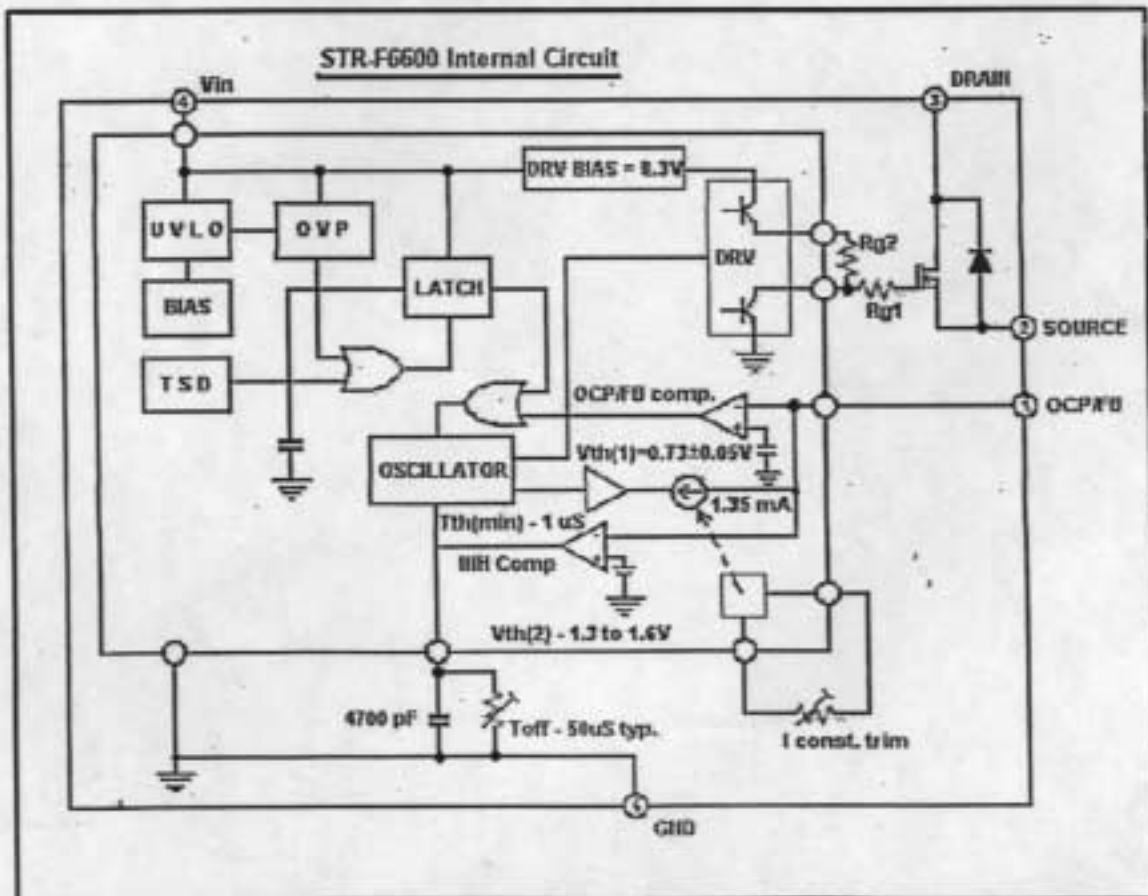

Electrical Characteristics
(refer to product specification for full details)

Absolute Maximum Ratings ($T_a = 25^\circ\text{C}$)

Parameter	Term	Symbol	Ratings	Unit	Note
Drain Current	3 - 2	I_d peak	See individual specs	A	Single pulse
Max Switching Current	3 - 2	I_d max	See individual specs	A	$V_{s-g} = 0 - 0.78\text{V}$ $T_a = -20 - +125^\circ\text{C}$
Avalanche energy	3 - 2	E_{as}	See individual specs	mJ	Single pulse
V/P voltage for cntrl circuit	4 - 5	V_{in}	35	V	
OCP/FB terminal voltage	1 - 5	V_{th}	6.0	V	
Pwr dis. of MOSFET	3 - 2	P_{d1}	See individual specs	W	
Pwr dis. for control circuit	4 - 5	P_{d2}	0.8	W	
Internal frame temp. in operation	—	T_f	-20 - +125	$^\circ\text{C}$	
Operating ambient temp.	—	T_{op}	-20 - +125	$^\circ\text{C}$	
Storage temperature	—	T_{stg}	-40 - +125	$^\circ\text{C}$	
MOSFET junction temp.	—	T_{ch}	150	$^\circ\text{C}$	

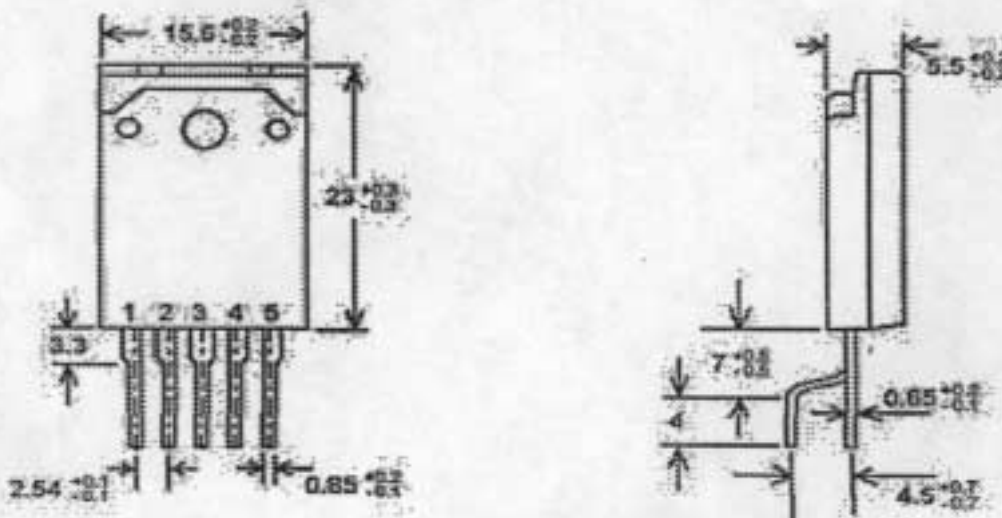

STR-F6600 Series - Outline Drawing

Recommended operating conditions

1. Inner frame temperature in operation
 $T_f = 115^\circ\text{C}$ maximum.
2. Time for input of quasi resonant signals.
 For the quasi resonant signal on the V_{ocres} terminal during quasi resonant operation, the signal duration and amplitude shall be as shown.
 $V_{th(2)}$ and $T_{th(2)}$ are as specified below.

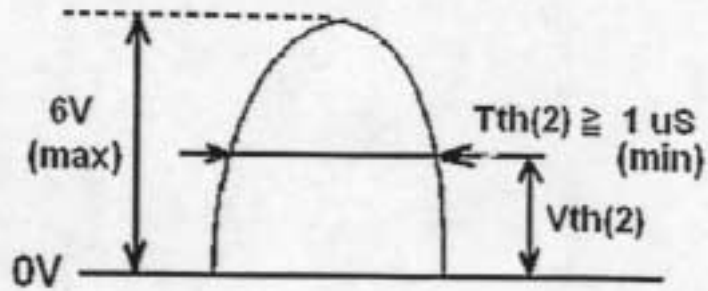

Electrical Characteristics for Control Circuit

$V_{in} = 18V$ ($T_a = 25^\circ\text{C}$) unless otherwise specified.

Parameter	Terminal	Symbol	Ratings			Unit
			Min.	Typ.	Max.	
Operation start Voltage	4 - 5	$V_{in(on)}$	14.4	16	17.6	V
Operation stop voltage	4 - 5	$V_{in(off)}$	9	10	11	V
Operating circuit current	4 - 5	$I_{in(on)}$	—	—	30	mA
Circuit current, non-operational	4 - 5	$I_{in(off)}$	—	—	100	μA
Maximum OFF time	—	$T_{off(max)}$	45	—	55	μsec
Minimum time for input of quasi resonant signals	1 - 5	$T_{th(2)}$	—	—	1.0	μsec
Minimum OFF time	—	$T_{off(min)}$	—	—	1.5	μsec
OCP/FB terminal threshold voltage 1	1 - 5	$V_{th(1)}$	0.68	0.73	0.78	V
OCP/FB terminal threshold voltage 2	1 - 5	$V_{th(2)}$	1.3	1.45	1.6	V
OCP/FB terminal sink current	1 - 2	I_{ocres}	1.2	1.35	1.5	A
OVP operation voltage	4 - 5	$V_{in(ovp)}$	20.5	22.5	24.5	V
Latch circuit sustaining voltage	4 - 5	$I_{in(H)}$	—	—	400	μA
Latch circuit release voltage	4 - 5	$V_{in(La.off)}$	6.6	—	8.4	V
Thermal shutdown operating temperature	—	$T_J(TSD)$	140	—	—	$^\circ\text{C}$

Lineup of STR-F6600 Series*

PART No.	MOSFET V _{ds} (V)	RDS(on) MAX. Ohms	V _{in} (V)	P _{out}
STR-F6512 (STR-F6502)	400	1.58	100	60
STR-F6614 (STR-F6511)	400	0.76	100	115
STR-F6616 (STR-F6513)	400	0.42	100	190
STR-F6624 (STR-F6514)	450	0.92	100 120	98 130
STR-F6626 (STR-F6516)	450	0.58	100 120	145 190
STR-F6628	450	0.35	100 120	225 290
STR-F6632 Still in development	500	2.62 estimated	100 120	36 50
STR-F6652	650	2.8	WIDE 220	40 86
STR-F6653 (STR-F6523)	650	1.95	WIDE 220	58 120
STR-F6654 (STR-F6524)	650	1.15	WIDE 220	92 190
STR-F6656	650	0.71	WIDE 220	150 300
STR-F6672 (STR-F6535)	900	7.7	220	25 (no fin) 50
STR-F6674	900	4.49	WIDE 220	28 76
STR-F6676 (STR-F6537)	900	2.81	WIDE 220	44 115

Application Review

The STR-F6600 series is a range of integrated hybrid switch mode power regulators, combining in the same package a dedicated fully protected control IC together with a choice of avalanche rated rugged power MOSFET; allowing the device to be tailored to the input voltage and power handling required. It is all housed in an isolated overmoulded SIP package eliminating the need for insulating components.

There are three possible modes of operation :

Quasi Resonant (Demag sensing)
flyback 20 - 300 KHz
- Optimum EMI and efficiency

Constant OFF time flyback
(50µS fixed dead time)
Pulse Ratio Control
- Low power standby mode.

Flyback operation synchronised to an external clock

Switching frequency is up to 300kHz

Voltage regulation is by peak current mode control and there is a genuine cycle by cycle current limit with no need for blanking.

Protection features include an Undervoltage Lockout with hysteresis to guard against over dissipation. Thermal protection is included.

The power limit can be controlled in an overload condition, reducing rectifier and MOSFET stresses regardless of input voltage. This is particularly important on start up to control the MOSFET losses and voltage stress.

Soft-start is internally programmed, no extra components are needed.