

MECHANICAL DATA

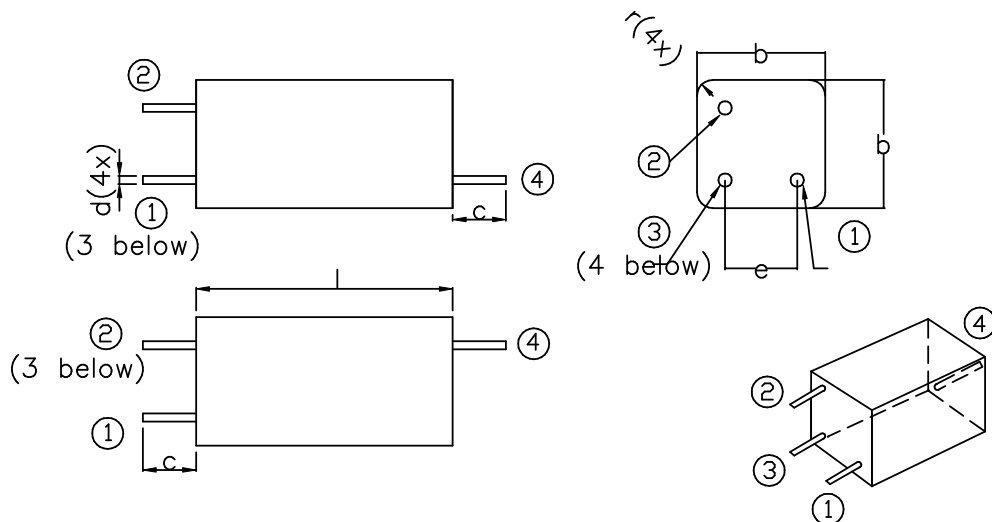

Dimensions (mm)

e : 5.0+/-0.5	c : 3 min	:
l : 16+/-0.5	f :	:
d : 0.5 dia	n :	:
r : R1.5	k :	:
a :	:	:
b : 8.0+/-0.3	:	:

Pin no.1 Primary (Red)	Pin no.2 Primary(St) & Secondary
Pin no.4 Secondary High Voltage(St)	

Remarks :

Operating temp. : -30°C to +80°C  
 Storage temp : -10°C to +55°C

				Number of sheets 2	Sheet no. 1
				Date 30.8.01	Sign. Chong SP
				Drawn by	
				Checked by	
				Type ZS 1052	
Index	Changes	Date	Sign.		



47 Ayer Rajah Crescent #06-12  
 Singapore 139947  
 Tel : (065) 7752022  
 Fax : (065) 7782370

OPERATING DATA

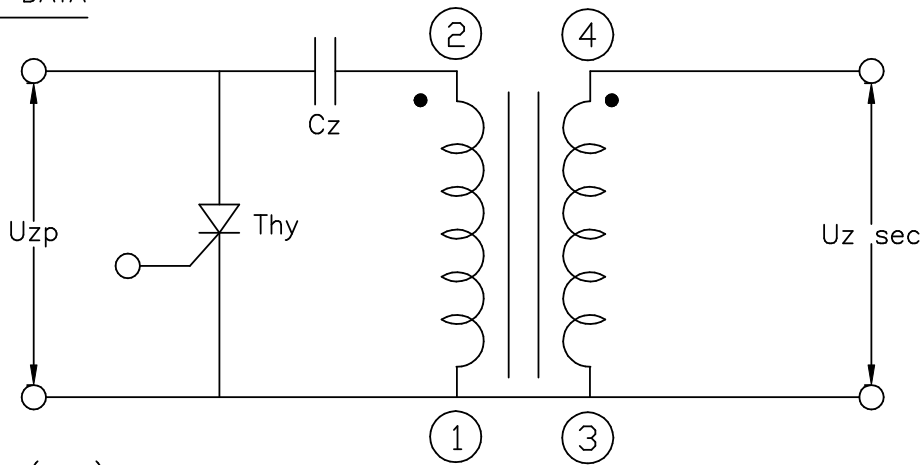

Dimensions (mm)

ITEMS	PRIMARY	SECONDARY
Resistance	325 mohm max	145+/-15 ohm
Primary Voltage, Uzp	Uzp = 300V	---
Primary Capacitance, Cz	0.047 uF	---
Secondary Voltage, Uz	---	9.0 kV min
Polarity of 1st peak	---	1st peak Negative
Inductance @ 1kHz	20+/-4 uH	20+/-5 mH

Typical waveform :

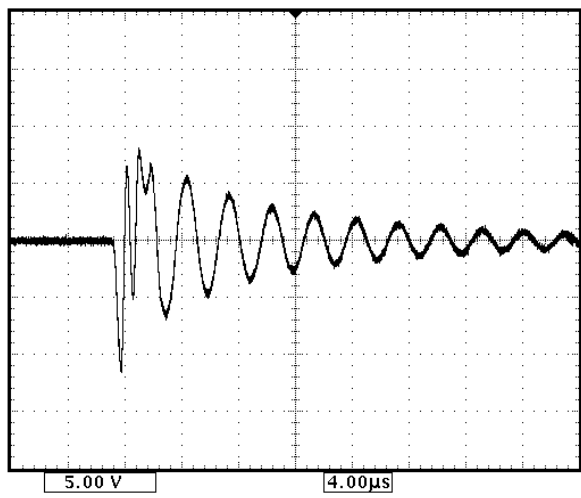

Unloaded high voltage output  
4 us/div 5 kV/div

				Number of sheets	Sheet no.
				2	2
				Date	Sign.
				30.8.01	Chang SP
				Checked by	
				Type	
				ZS 1052	
Index	Changes	Date	Sign.		



47 Ayer Rajah Crescent #06-12  
Singapore 139947  
Tel : (065) 7752022  
Fax : (065) 7782370