



PRELIMINARY

# Data Sheet

# FARM™

Filter/

Autoranging Rectifier Module

Up to 1000 Watts



Shown actual size:  
2.28 x 2.2 x 0.5 in  
57,9 x 55,9 x 12,7 mm

## Features

- EMI filtering
- Choice of 500W or 750W modules
- 96% Efficiency
- Autoranging 115/230Vac input
- Microprocessor controlled
- Inrush current limiting
- Mini sized package
- Power fail signal
- Module enable

## Product Highlights

The FARM (Filter/Autoranging Rectifier Module) is an AC front-end module which provides EMI filtering, autoranging line rectification and inrush current limiting. The FARM is available in either 500/750W or 750/1000W models in a mini sized package measuring only 2.28" x 2.2" x 0.5".

The FARM interfaces directly with worldwide AC mains and may be used with Vicor 1st or 2nd Generation 300V input DC-DC converters to realize an autoranging, high density, low profile switching power supply. The FARM includes a microcontroller that continuously monitors the AC line to control bridge/doubler operation. The user need only provide external capacitance to satisfy system hold-up requirements.

Vicor 2nd Generation packaging technology offers flexible mounting options for various manufacturing processes. The FARM may be installed as a conventional leaded device for on-board applications, in-board for low profile, height restricted applications, socketed or surface mounted with optional ModuMate interconnect products.

## Absolute Maximum Rating

Parameter	Rating	Unit	Notes
L to N voltage	264	Vac	Continuous
L to N voltage	280	Vac	100ms
+Out to -Out voltage	400	Vdc	
B OK to -Out voltage	16	Vdc	
EN to -Out voltage	16	Vdc	
Mounting torque	4-6(0.45-0.68)	in-lbs (N-m)	6 each, 4-40 screw
Pin soldering temperature	500 (260)	°F (°C)	<5 sec; wave solder
Pin soldering temperature	750 (390)	°F (°C)	<7 sec; hand solder

## Thermal Resistance and Capacity

Parameter	Min	Typ	Max	Unit
Baseplate to sink; flat, greased surface		0.16		°C/Watt
Baseplate to sink; with thermal pad (P/N 20264)		0.14		°C/Watt
Baseplate to ambient		8.0		°C/Watt
Baseplate to ambient; 1000 LFM		1.9		°C/Watt

## Part Numbering

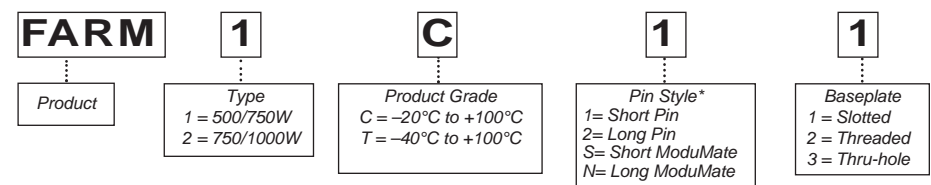

\*Pin styles S & N are compatible with the ModuMate interconnect system for socketing and surface mounting.

# PRELIMINARY

## Electrical Characteristics

Electrical characteristics apply over the full operating range of input voltage, output power and baseplate temperature, unless otherwise specified. All temperatures refer to the operating temperature at the center of the baseplate. Specifications apply for AC mains having up to 5% total harmonic distortion.

### ■ MODULE INPUT SPECIFICATIONS (FARM1xxx, FARM2xxx)

Parameter	Min	Typ	Max	Unit	Notes
Operating input voltage	90		132	Vac	Autoranging (doubler mode)
Operating input voltage	180		264	Vac	Autoranging (bridge mode)
Input undervoltage			90	Vac	No damage
AC line frequency	47		63	Hz	C-Grade
AC line frequency	47		880	Hz	T-Grade
Power factor	0.60		0.65		Typical line
Inrush current					
FARM1xxx			30	Amps	264Vac peak line, cold start
FARM2xxx			60	Amps	264Vac peak line, cold start
Input surge withstand	2kV-50 $\mu$ s common mode 1kV-50 $\mu$ s differential mode				EN61000-4-5

### ■ MODULE OUTPUT SPECIFICATIONS

Parameter	FARM1xxx			FARM2xxx			Unit	Notes
	Min	Typ	Max	Min	Typ	Max		
Output power	0		500	0		750	Watts	90-132Vac
Output power	0		750	0		1000	Watts	180-264Vac
Efficiency, 120Vac	94	96		94	96		%	
Efficiency, 240Vac	94	96		94	96		%	
Output voltage	250		370	250		370	Vdc	90-264Vac
Hold-up capacitance			1,800			3,300	$\mu$ F	

### ■ SAFETY SPECIFICATIONS (FARM1xxx, FARM2xxx)

Parameter	Min	Typ	Max	Unit	Notes
Safety approvals					UL 1950, CSA 22.2 No. 950, TÜV, VDE, EN60950, CE Marked
Isolation voltage (in to out)	None				Isolation provided by DC-DC converter(s)
Isolation voltage (I/O to baseplate)	1500			Volts, rms	
Leakage current			1.2	mA	264Vac

# PRELIMINARY

## Electrical Characteristics (continued)

### ■ MODULE CONTROL SPECIFICATIONS

Parameter	Min	Typ	Max	Unit	Notes
AC Bus OK (B OK)					
Low state resistance			15	Ω	To negative output - Bus normal
Low state current			50	mA	Bus normal
High state voltage	14.8	15.0	15.2	Vdc	Bus abnormal, 27K internal pull up to 15Vdc (see Fig.11)
B OK true threshold	235	240	245	Vdc	Output Bus voltage
B OK false threshold	200	205	210	Vdc	Output Bus voltage
Module Enable (EN)					
Low state resistance			15	Ω	To negative output - Converters disabled
Low state current			50	mA	
High state voltage	14.8	15.0	15.2	Vdc	150K internal pull up to 15Vdc (see Fig. 10)
Enable threshold	235	240		Vdc	Output bus voltage
Disable threshold	185	190	195	Vdc	Output bus voltage
AC Bus OK - Module Enable, differential error*	15	17	20	Vdc	AC Bus OK and Module Enable thresholds track

\* Tracking error between BUS OK and Enable thresholds

### ■ MODULE GENERAL SPECIFICATIONS

Parameter	Min	Typ	Max	Unit	Notes
MTBF		>1,000,000		Hours	25°C, Ground Benign
Baseplate material					Aluminum
Cover					Polyetherimide
Pin Material					Copper, Tin/lead solder dipped
Weight		3.1(88)		Ounces (grams)	
Size		2.28 x 2.2 x 0.5 57,9 x 55,9 x 12,7		Inches (mm)	
Storage Temperature (C, T-Grade)	-40		+125	°C	
Operating Temperature (C-Grade)	-20		+100	°C	Baseplate
(T-Grade)	-40		+100	°C	Baseplate

Operating Characteristics

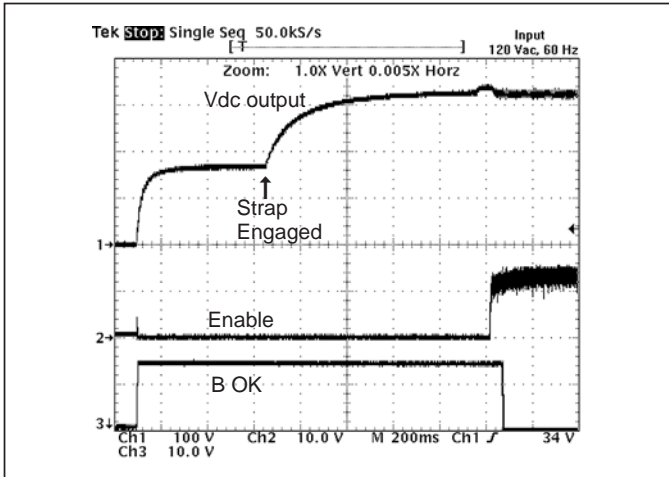

Figure 1—Start-up at 120Vac input

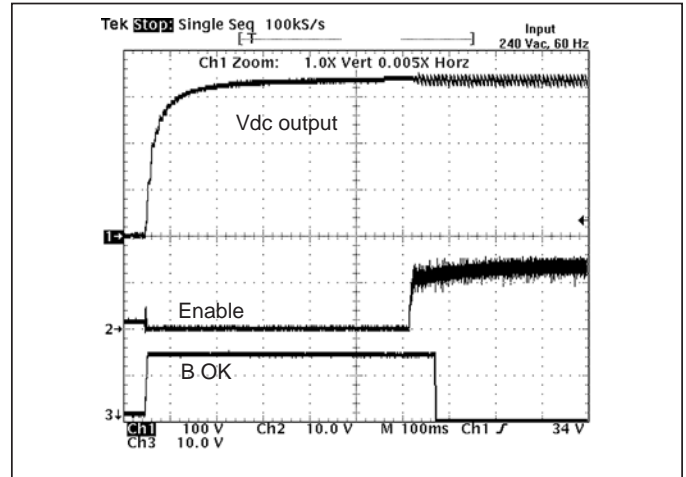

Figure 2—Start-up at 240Vac input

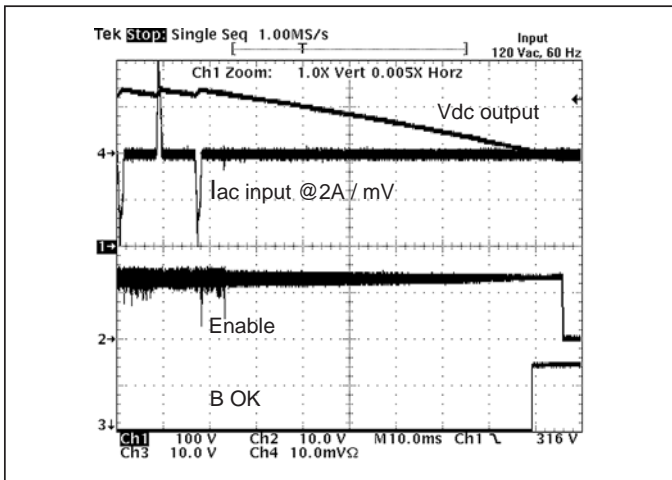

Figure 3—Power down, from 120Vac

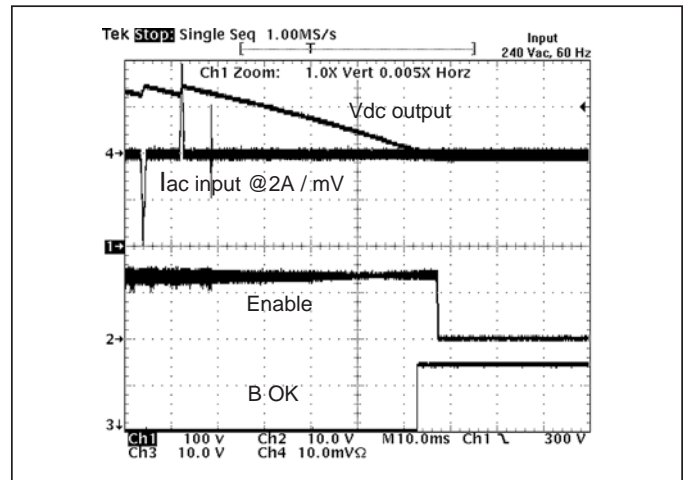

Figure 4—Power down, from 240Vac

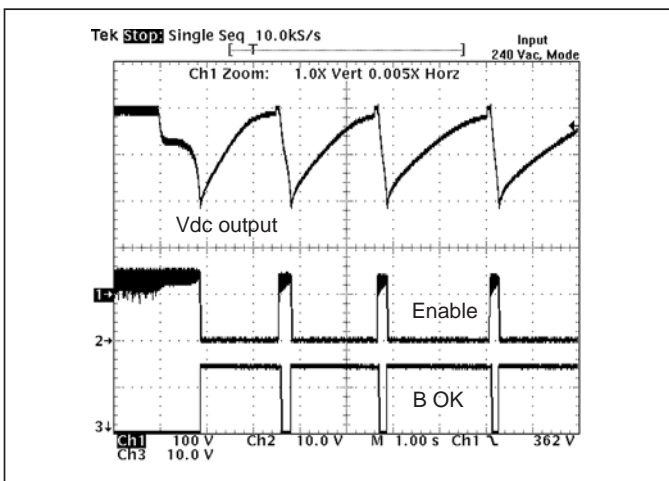

Figure 5—Output overvoltage protection 240Vac range

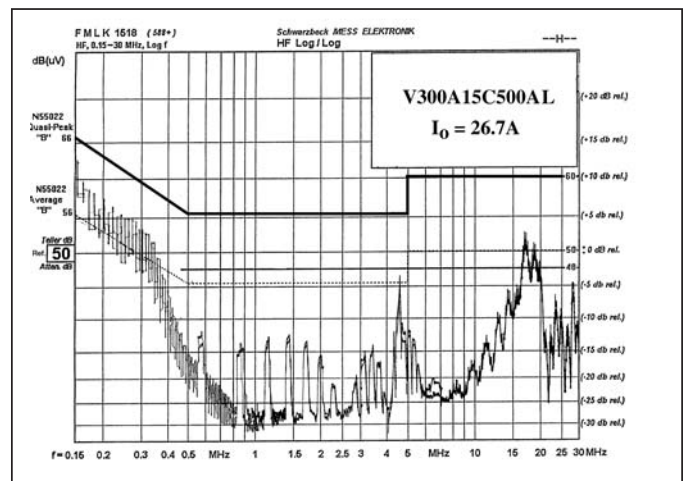

Figure 6—Typical Conducted Emissions

## Application Note

The Filtered, Autoranging Rectifier Module (FARM) provides an effective solution for the AC front end of a power supply built with Vicor DC-DC converters. This high performance power system building block satisfies a broad spectrum of requirements and agency standards.

In addition to providing transient/surge immunity and EMI filtering, the FARM contains all of the power switching and control circuitry necessary for autoranging rectification, inrush current limiting, and overvoltage protection. This module also provides converter enable and status functions for orderly power up/down control or sequencing. To complete the AC front end configuration, the user only needs to add hold-up capacitors, and a few discrete components.

### Functional Description

**Power-Up Sequence.** (see Fig. 8):

- 1.1** Upon application of input power, the output bus capacitors begin to charge. The thermistor limits the charge current, and the exponential time constant is determined by the hold-up capacitor value and the thermistor cold resistance. The slope ( $dv/dt$ ) of the capacitor voltage versus time approaches zero as the capacitors become charged to the peak of the AC line voltage.

The switch that bypasses the inrush limiting PTC (positive temperature coefficient) thermistor is open when power is applied, as is the switch that engages the strap for voltage doubling. (see Fig. 7). In addition, the converter modules are disabled via the Enable (EN) line, and Bus-OK (BOK) is high.

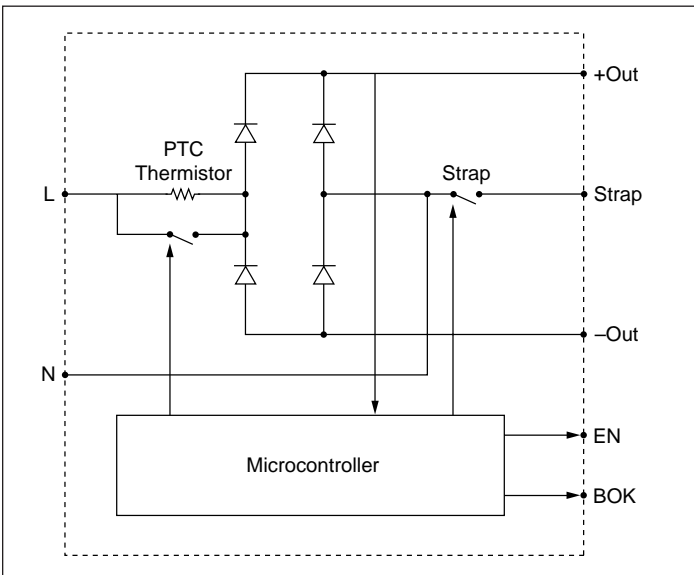

Figure 7—Functional block diagram: autoranging rectifier

- 2.1** If the bus voltage is less than 200V as the slope nears zero, the voltage doubler is activated, and the bus voltage climbs exponentially to twice the peak line voltage. If the bus voltage is greater than 200V, the doubler is not activated.
- 3.1** If the bus voltage is greater than 235V as the slope approaches zero, the inrush limiting thermistor is bypassed. Below 235V, it is not bypassed.
- 4.1** The converters are enabled 50 milliseconds after the thermistor bypass switch is closed.
- 5.1** Bus-OK is asserted after an additional 50 millisecond delay to allow the converter outputs to settle within specification.

**Power-Down Sequence.** (see Fig. 8) When input power is turned off or fails, the following sequence occurs as the bus voltage decays:

- 1.2** Bus-OK is deasserted when the bus voltage falls below 210Vdc.
- 2.2** The converters are disabled when the bus voltage falls below 190Vdc. If power is reapplied after the converters are disabled, the entire power-up sequence is repeated. If a momentary power interruption occurs and power is reestablished before the bus reaches the disable threshold, the power-up sequence is not repeated, i.e., the power conversion system “rides through” the momentary interruption.

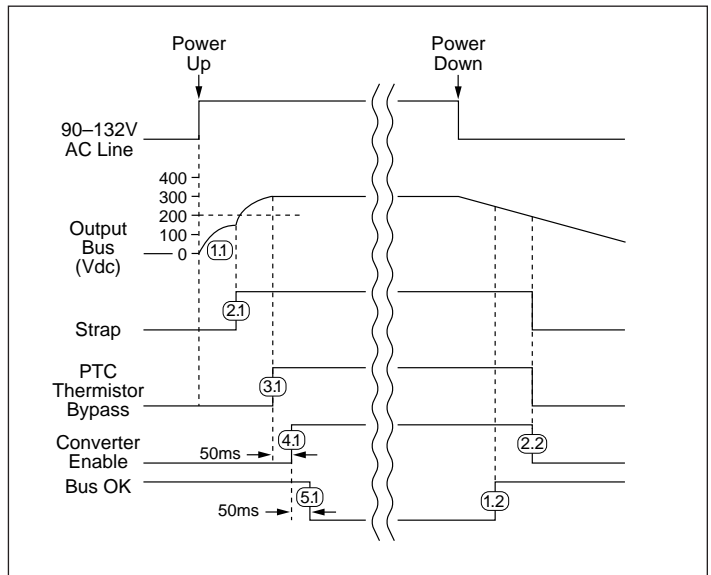

Figure 8—Timing diagram: power up/down sequence

Application Note (continued)

Off-Line Power Supply Configuration

The FARM maintains the DC output bus voltage between 250 and 370Vdc over the entire input voltage range, which is compatible with Vicor 2nd Generation, 300V input converters as well as 1st Generation VI-26x and VI-J6x DC-DC converters. The FARM automatically switches to the proper bridge or doubler mode depending on the input voltage, eliminating the possibility of damage due to improper line connection. The FARM1xxx is rated at 500W in the low range (90-132Vac input), and 750W in the high range (180-264Vac input). The FARM2xxx is rated for 750W and 1000W for the low and high input ranges respectively. Either of these modules can serve as the AC front end for any number and combination of compatible converters as long as the maximum power rating is not exceeded.

**Strap (ST) Pin.** In addition to input and output power pin connections, it is necessary to connect the Strap pin to the center junction of the series hold-up capacitors (C1, C2, see Fig. 9) for proper (autoranging) operation. Gas tubes V1 and V2 provide capacitor protection. The bleeder resistors (R1, R2, see Fig. 9) discharge the hold-up capacitors when power is switched off. Capacitors C7 and C8 are recommended if the holdup capacitors are located more than 3 inches from the FARM output pins.

**Enable (EN) Pin.** (see Fig. 10) The Enable pin must be connected to the PC or Gate-In pin of all converter modules to disable the converters during power-up. Otherwise, the converters would attempt to start while the hold-up capacitors were being charged through an unbypassed current limiting thermistor, preventing the bus voltage from reaching the thermistor bypass threshold, thus disabling the power supply. The Enable output (the drain of an N channel MOSFET) is internally pulled up to 15V through a 150kΩ resistor.

A signal diode should be placed close to and in series with the PC or (Gate-In) pin of each converter to eliminate the possibility of control interference between converters. The Enable pin switches to the high state (15V) with respect to the negative output power pin to turn on the converters after the power-up inrush is over. The Enable function also provides input overvoltage protection for the converters by turning off the converters if the DC bus voltage exceeds 400Vdc. The thermistor bypass switch opens if this condition occurs, placing the thermistor in series with the input voltage, which reduces the bus voltage to a safe level while limiting input current in case the varistors conduct. The thermistor bypass switch also opens if a fault or overload reduces the bus voltage to less than 180Vdc.

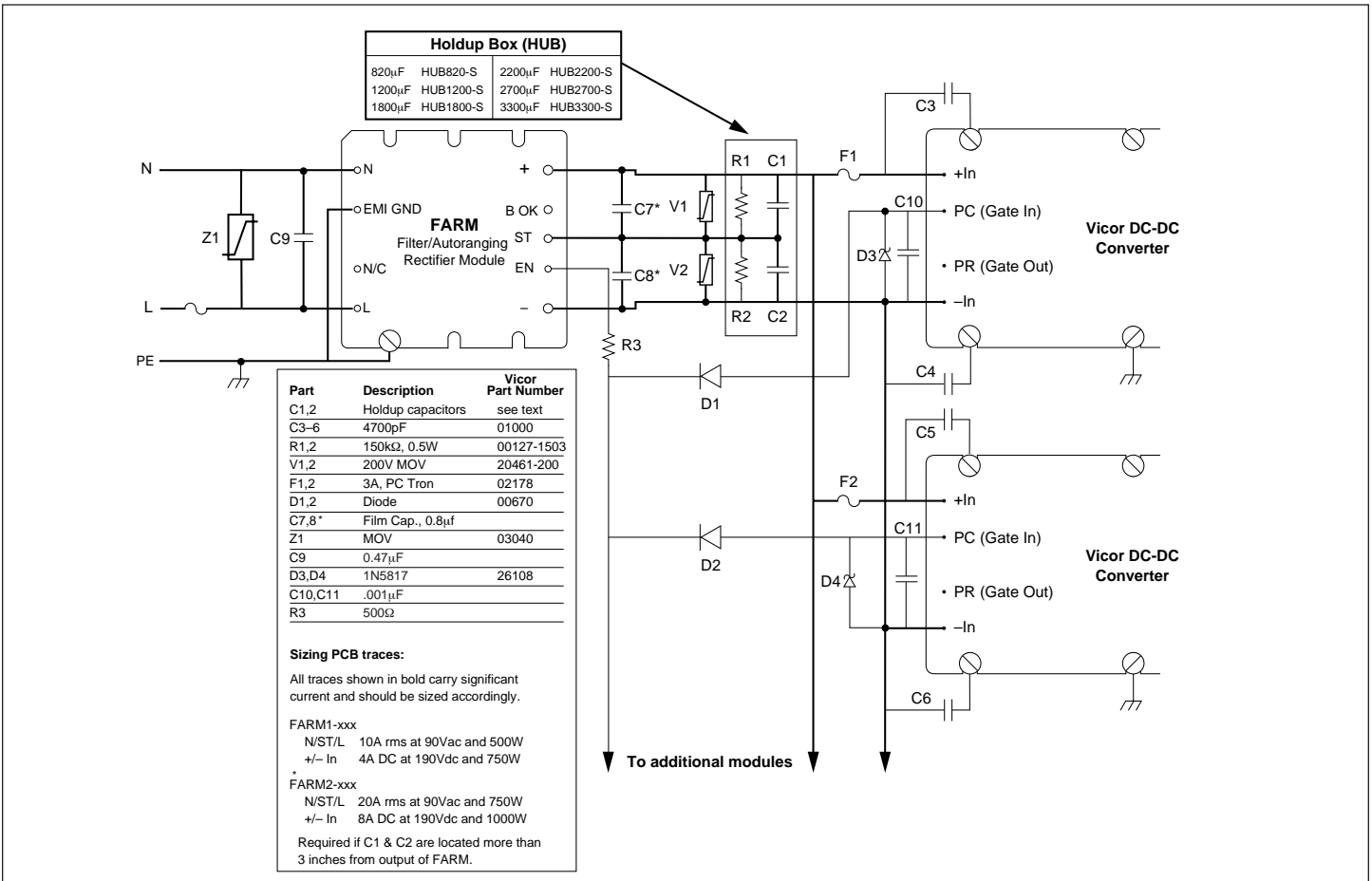

Figure 9—Converter connections

Application Note (continued)

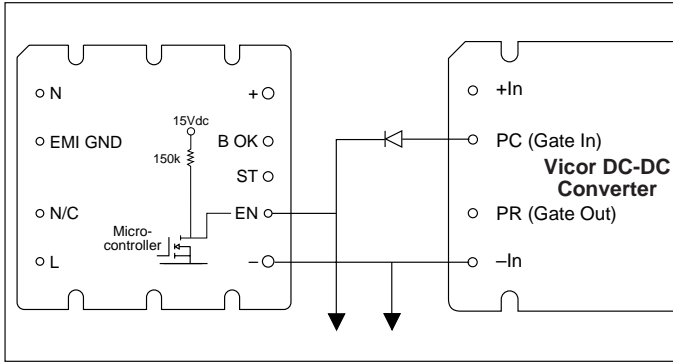

Figure 10—Enable (EN) function

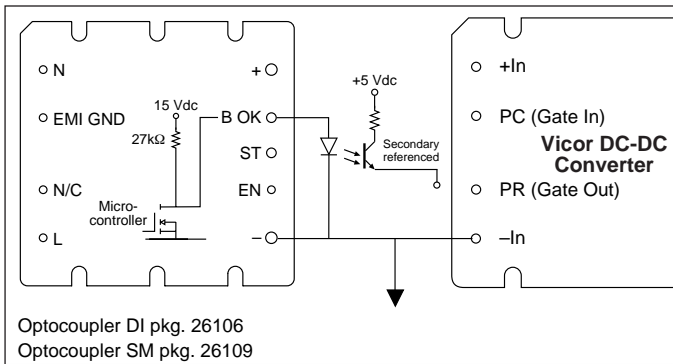

Figure 11—Bus OK (BOK) isolated power status indicator

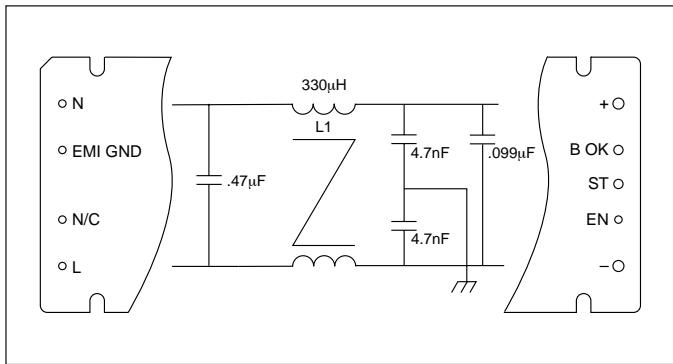

Figure 12—Internal filter

**Bus-OK (BOK) Pin.** (see Fig. 11) The Bus-OK pin is intended to provide early-warning power fail information and is also referenced to the negative output pin.

*Caution:* There is no input to output isolation in the FARM. It is necessary to monitor Bus-OK via an optoisolator if it is to be used on the secondary (output) side of the converters. A line isolation transformation should be used when performing scope measurements. Scope probes should never be applied simultaneously to the input and output as this will destroy the unit.

**Filter.** (see Fig. 12) An integral input filter consists of a common mode choke and Y rated capacitors (line-ground) plus two X rated capacitors (line-line). This filter configuration provides common mode and differential mode insertion loss in the frequency range between 100kHz and 30MHz as illustrated in Figure 6.

**Hold-up Capacitors.** Hold-up capacitor values should be determined according to output bus voltage ripple, power fail hold-up time, and ride-through time (see Fig. 13). Many applications require the power supply to maintain output regulation during a momentary power failure of specified duration, i.e., the converters must hold-up or ride through such an event while maintaining undisturbed output voltage regulation. Similarly, many of these same systems require notification of an impending power failure in order to allow time to perform an orderly shutdown.

The energy stored on a capacitor which has been charged to voltage V is:

$$\epsilon = 1/2(CV^2) \quad (1)$$

Where:  $\epsilon$  = stored energy  
 C = capacitance  
 V = voltage across the capacitor

Energy is given up by the capacitors as they are discharged by the converters. The energy expended (the power-time product) is:

$$\epsilon = P\Delta t = C(V_1^2 - V_2^2) / 2 \quad (2)$$

Where: P = operating power  
 $\Delta t$  = discharge interval  
 $V_1$  = capacitor voltage at the beginning of  $\Delta t$   
 $V_2$  = capacitor voltage at the end of  $\Delta t$

Rearranging Equation 2 to solve for the required capacitance:

$$C = 2P\Delta t / (V_1^2 - V_2^2) \quad (3)$$

Application Note (continued)

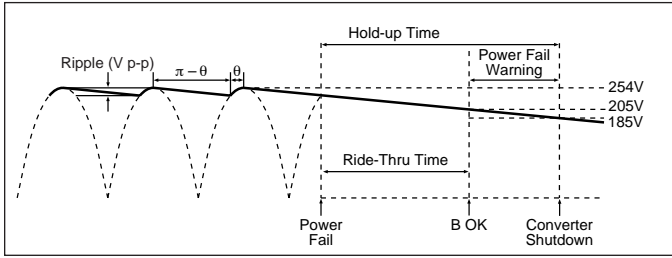

Figure 13—Hold-up time

The power fail warning time ( $\Delta t$ ) is defined as the interval between B OK and converter shutdown (EN) as illustrated in Fig. 13. The Bus-OK and Enable thresholds are 205V and 185V, respectively. A simplified relationship between hold-up time, operating power, and bus capacitance is obtained by inserting these constants:

$$C = 2P\Delta t / (205^2 - 185^2)$$

$$C = 2P\Delta t / (7,800)$$

It should be noted that the series combination (C1, C2, see Fig. 9) requires each capacitor to be twice the calculated value, but the required voltage rating of each capacitor is reduced to 200V.

Allowable ripple voltage on the bus (or ripple current in the capacitors) may define the capacitance requirement. Consideration should be given to converter ripple rejection and resulting output ripple voltage. The ripple rejection (R) of Vicor converters is specified as a function of the input/output voltage ratio:

$$R = 30 + 20\log(V_{in} / V_{out}) \quad (4)$$

For example, a converter whose output is 15V and nominal input is 300V will provide 56dB ripple rejection, i.e., 10V p-p of input ripple will produce 15mV p-p of output ripple (see Fig. 17). Equation 3 is again used to determine the required capacitance. In this case,  $V_1$  and  $V_2$  are the instantaneous values of bus voltage at the peaks and valleys (see Fig. 13) of the ripple, respectively. The capacitors must hold up the bus voltage for the time interval ( $\Delta t$ ) between peaks of the rectified line as given by:

$$\Delta t = (\pi - \theta) / 2\pi f \quad (5)$$

Where:  $f$  = line frequency  
 $\theta$  = rectifier conduction angle

The approximate conduction angle is given by:

$$\theta = \text{Cos}^{-1}(V_2/V_1)$$

(6)

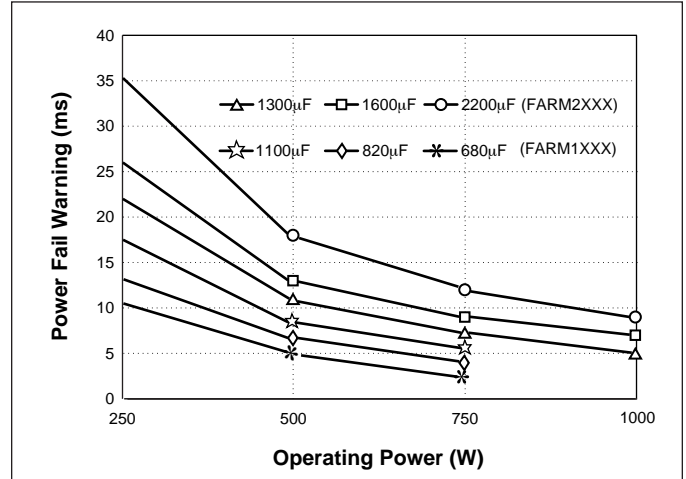

Figure 14—Hold-up time vs. operating power and total bus capacitance, series combination of C1, C2 (see Fig. 9)

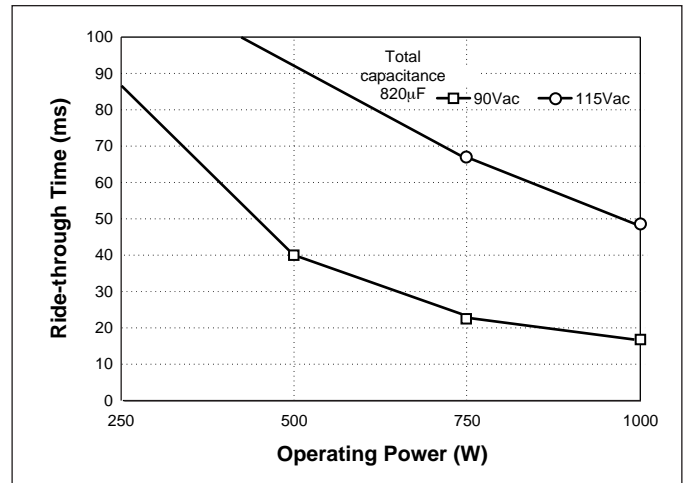

Figure 15—Ride-through time vs. operating power

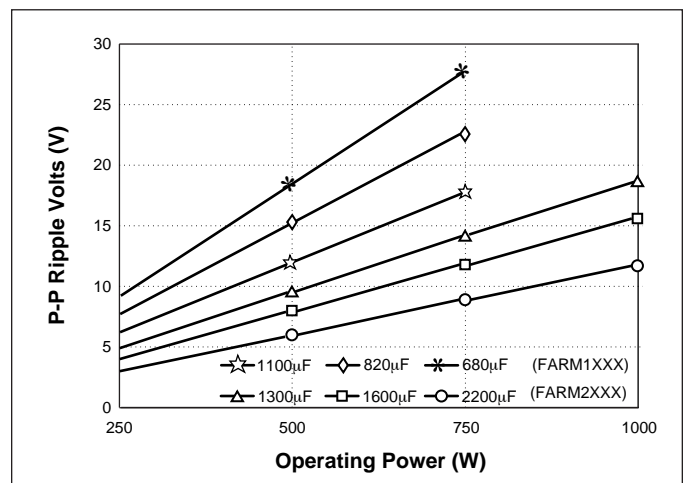

Figure 16—Ripple voltage vs. operating power and bus capacitance, series combination of C1, C2 (see Fig. 9)



## Application Note (continued)

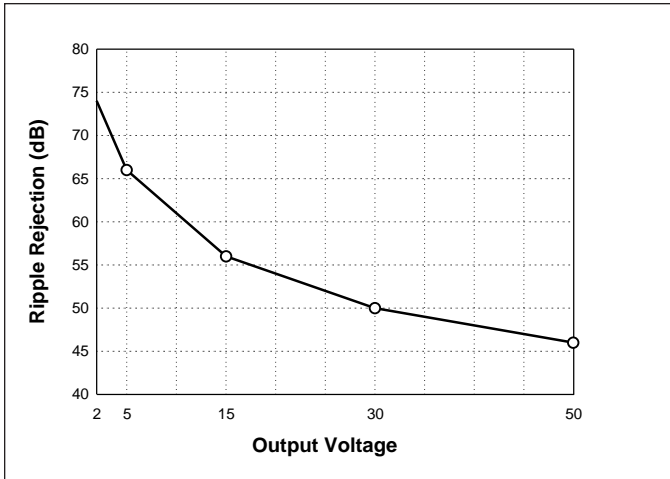

Figure 17—Converter ripple rejection vs. output voltage

Another consideration in hold-up capacitor selection is their ripple current rating. The capacitors' rating must be higher than the maximum operating ripple current. The approximate operating ripple current (rms) is given by:

$$I_{rms} = 2P/V_{ac} \quad (7)$$

Where: P = total output power  
 $V_{ac}$  = operating line voltage

Calculated values of bus capacitance for various hold-up time, ride-through time, and ripple voltage requirements are given as a function of operating power level in Figures 14, 15, and 16, respectively.

### Example

In this example, the output required from the DC-DC converter at the point of load is 12Vdc at 320W. Therefore, the output power from the FARM would be 375W (assuming a converter efficiency of 85%). The desired hold-up time is 9 ms over an input range of 90 to 264Vac.

### Determining Required Capacitance for Power Fail

**Warning.** Figure 14 is used to determine capacitance for a given power fail warning time and power level, and shows that the total bus capacitance must be at least 820  $\mu$ F. Since two capacitors are used in series, each capacitor must be at least 1,640  $\mu$ F. Note that warning time is not dependent on line voltage. A hold-up capacitor calculator is available on the Vicor website, at vicorpower.com.

**Determining Ride-through Time.** Figure 15 illustrates ride-through time as a function of line voltage and output power, and shows that at a nominal line of 90Vac, ride-through would be 68 ms. Ride-through time is a function of line voltage.

**Determining Ripple Voltage on the Hold-up Capacitors.** Figure 16 is used to determine ripple voltage as a function of operating power and bus capacitance, and shows that the ripple voltage across the hold-up capacitors will be 12V p-p.

**Determining the Ripple on the Output of the DC-DC Converter.** Figure 17 is used to determine the ripple rejection of the DC-DC converter and indicates a ripple rejection of approximately 60 dB for a 12V output. Since the ripple on the bus voltage is 12Vac and the ripple rejection of the converter is 60 dB, the output ripple of the converter due to ripple on its input (primarily 120 Hz) will be 12mV p-p. Note that 2nd Generation converters have greater ripple rejection than either VI-200s or VI-J00s.

*For more information about designing an autoranging AC input power supply using the FARM and Vicor DC-DC converter modules, contact Vicor Applications Engineering at the nearest Vicor Technical Support Center, or send E-mail to apps@vicor.com.*

• • •

Mechanical Diagram

Converter Pins		
No.	Function	Label
1	Neutral	N
2	EMI	GND
3		NC
4	Line	L
5	-Out	-
6	Enable	EN
7	Strap	ST
8	BUS OK	BOK
9	+Out	+

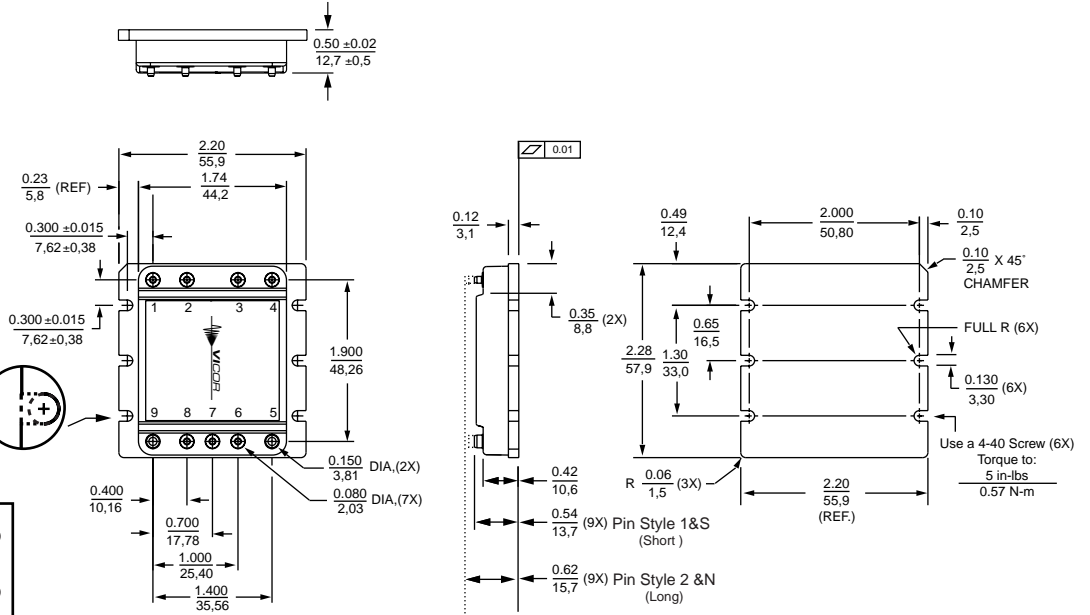
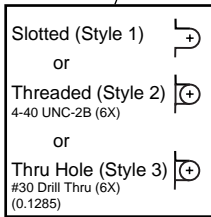

PCB Mounting Specifications

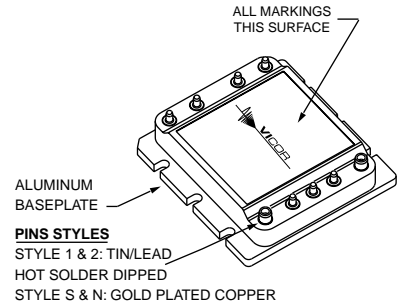
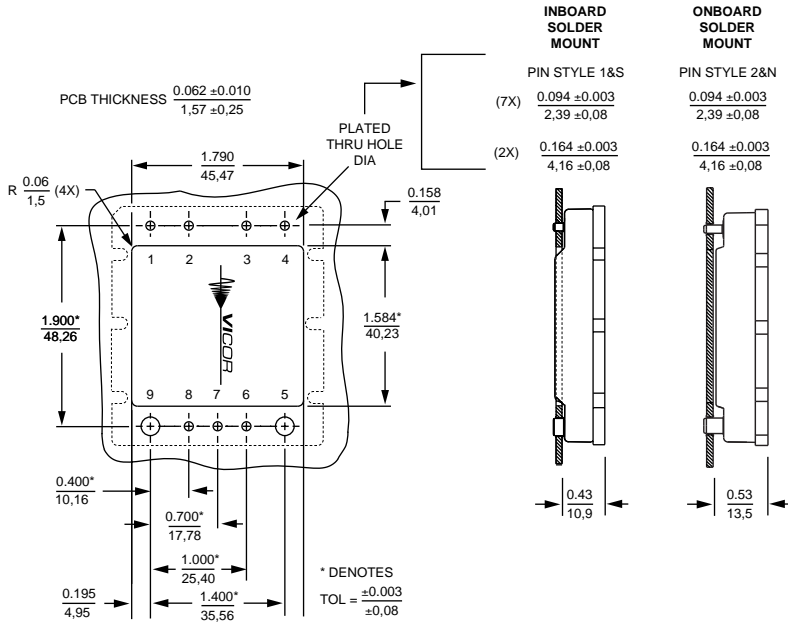



**Vicor's comprehensive line of power solutions includes modular, high density DC-DC converters and accessory components, configurable power supplies, and custom power systems.**

Information furnished by Vicor is believed to be accurate and reliable. However, no responsibility is assumed by Vicor for its use. No license is granted by implication or otherwise under any patent or patent rights of Vicor. Vicor components are not designed to be used in applications, such as life support systems, wherein a failure or malfunction could result in injury or death. All sales are subject to Vicor's Terms and Conditions of Sale, which are available upon request.

**Specifications are subject to change without notice.**



*Component Solutions  
for Your Power System*

**Vicor Corporation**  
25 Frontage Road  
Andover, MA, USA 01810  
Tel: 800-735-6200  
Fax: 978-475-6715

**Email**

Vicor Express: [vicorexp@vicr.com](mailto:vicorexp@vicr.com)  
Technical Support: [apps@vicr.com](mailto:apps@vicr.com)