

SANYO	No.2003B	LC8910 Series
		Remote Control LSI

Overview

The LC8910 series are LSIs designed for transmit/receive use in remote control system applications. The adoption of a statistical processing circuit entirely original with Sanyo enhances noise-resisting capability greatly.

Applications

- HA (home automation) use :
Air-conditioning equipment, lighting equipment, solar system, radio equipment, home appliances
- Crime preventing monitor system, disaster preventing monitor system :
Smoke detector, gas detector, fire detector, burglarproof system, electronic key
- Communication system :
Radio pager, remote data collecting system

Type No.	Application	Unique Address Length (bits)*	Data Length (bits)	Package
LC8910	Controller	0	20 max	DIP24
LC8912	Terminal	8	4	DIP28
LC8913	Terminal	12	8	DIP40

*: Unique address designates individually assigned network addresses.

Features

- LSIs designed for transmit/receive use
- Transmission line access control : Master polling and CSMA/CD
- Biphasic data transmission codes and variable transmission rate
- Modulation : Base band/AM (by on-chip modulation/demodulation circuit)
- Statistical processing circuit adopted to enhance noise-resisting capability greatly
- The LC8910 is capable of interfacing to any microcomputer.
- The LC8912, 8913 require a minimum number of external parts to make up a system.
- Answerback function and broadcast communication function
- CMOS process for low power dissipation

Package Dimensions 3068A [LC8910]
(unit : mm)

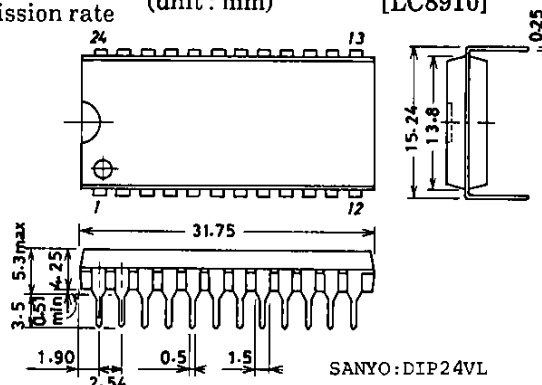

Package Dimensions 3069A [LC8912]
(unit : mm)

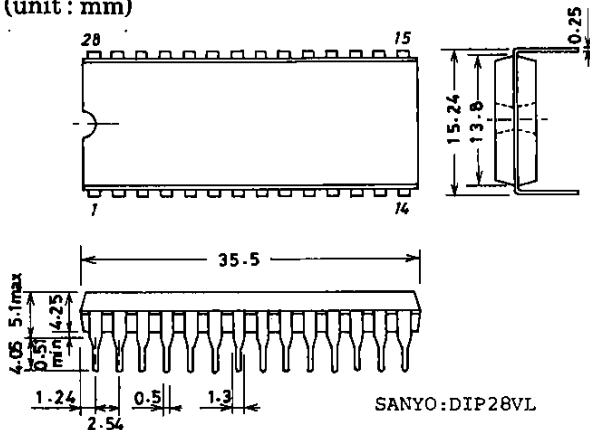

Package Dimensions 3077 [LC8913]
(unit : mm)

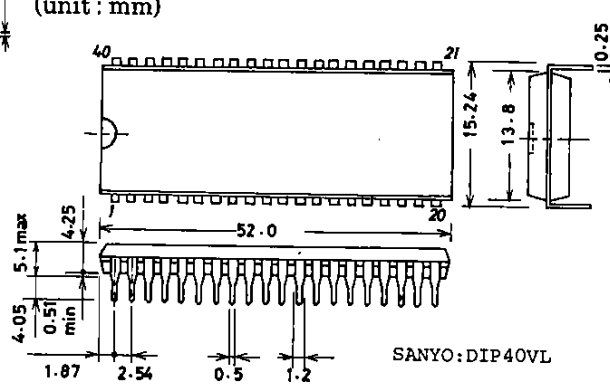

SANYO Electric Co., Ltd. Semiconductor Business Headquarters
TOKYO OFFICE Tokyo Bldg., 1-10, 1 Chome, Ueno, Taito-ku, TOKYO, 110 JAPAN

D1694TH / 8010TA/D096KI,TS No.2003-1/4

LC8910 Series

Specifications

- Transmission mode : Half-duplex transmission
- Transmission line access control : CSMA/CD
- Modulation : Base band/AM
- Code : Biphase code
- Transmission rate : 15kb/s to 10b/s
- Error detection : Bit rule error
CKSM error
Overrun error
Underrun error
Transmission error by collision detection
- Answerback : Output data/input data
- Broadcast communication : General broadcast/group broadcast
- Supply voltage : Single 5V
- Power dissipation : 15mW typ

Signal Format

PR	ID	DC	ADRS	DATA	CKSM
PR : Preamble				12/32 bits	
ID : Control code				4 bits	
DC : Data count				4 bits	
ADRS : Address				0 to 12 bits	
DATA : Data				0 to 20 bits	
CKSM : Checksum				4 bits	

Pin Description

1) LC8910

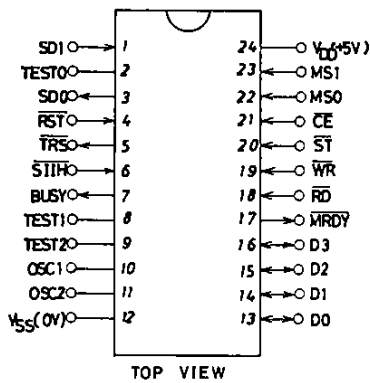

- SDI : Receive signal input
- SDO : Transmit signal output
- RST : Reset input
- TRS : Transmit mode output
- STIH : Receive disable signal input
- BUSY : Busy signal output
- TEST0 to 2 : Test input
- OSC1, 2 : Clock pins
- D0 to 3 : Data input/output
- MRDY : Reception completed signal output
- ST : Start input
- RD : Read input
- WR : Write input
- CE : Chip enable input
- MS0, 1 : Mode select signal input

2) LC8912

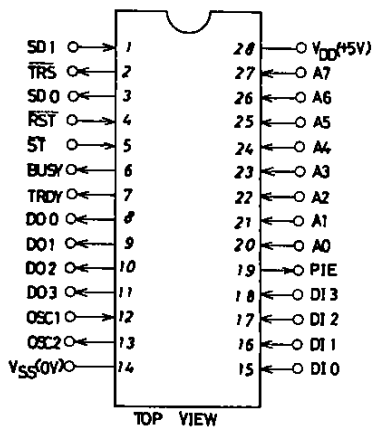

- SDI : Receive signal input
- TRS : Transmit mode output
- SDO : Transmit signal output
- RST : Reset input
- ST : Start input
- BUSY : Busy signal output
- TRDY : Terminal ready
- DO0 to 3 : Data output
- OSC1, 2 : Clock pins
- DI0 to 3 : Data input
- PIE : Parameter/address select signal output
- A0 to 7 : Address/parameter input

3) LC8913

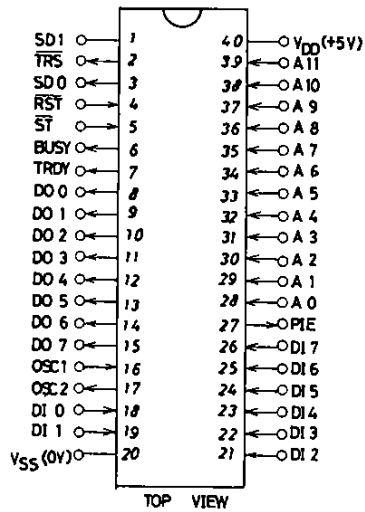

- SDI : Receive signal input
- TRS : Transmit mode output
- SDO : Transmit signal output
- RST : Reset input
- ST : Start input
- BUSY : Busy signal output
- TRDY : Terminal ready
- DO0 to 7 : Data output
- OSC1, 2 : Clock pins
- DI0 to 7 : Data output
- PIE : Parameter/address select signal output
- A0 to 11 : Address/parameter input

Absolute Maximum Ratings at Ta = 25°C, VSS = 0V

Maximum Supply Voltage	V _{DD} max	-0.3 to +7.0	V	unit
Input Voltage	V _I , V _O	-0.3 to V _{DD} + 0.3	V	
Storage Temperature	Topr	-55 to +125	°C	
Operating Temperature	Topg	-30 to +70	°C	

Allowable Operating Conditions at Ta = -30 to +70°C

Supply Voltage	V _{DD}	min: 4.5	typ: 5.0	max: 5.5	unit: V
Input Voltage Range	V _{IN}	0		V _{DD}	V

Electrical Characteristics at V_{DD} = 4.5 to 5.5V, Ta = -30 to +70°C

'H'-Level Input Voltage	V _{IH1}	Schmitt trigger	min: 2.5	typ:	max:	unit: V
	V _{IH2}		2.2			V
	V _{IH3}	RST pin	V _{DD} - 0.9			V
'L'-Level Input Voltage	V _{IL1}	Schmitt trigger			0.6	V
	V _{IL2}				0.8	V
	V _{IL3}	RST pin			0.6	V
'H'-Level Output Voltage	V _{OH}	I _{OH} = -0.4mA	2.4			V
'L'-Level Output Voltage	V _{OL}	I _{OL} = 2mA			0.4	V
Input Leakage Current	I _L	V _I = V _{SS} , V _{DD}	-25		25	μA
Output Leakage Current	I _{OZ}	Output pin : 'H' impedance	-100		100	μA
OSC Amp 'H'-Level Input Voltage	V _{IHOSC}		0.8V _{DD}			V
OSC Amp 'L'-Level Input	V _{ILOSC}				0.2V _{DD}	V

Sample Application Circuit

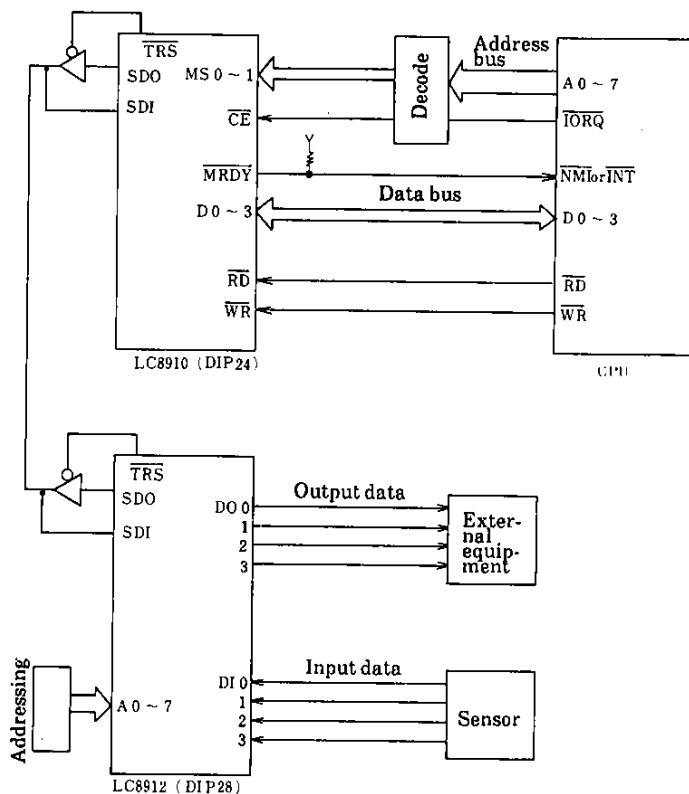

■ No products described or contained herein are intended for use in surgical implants, life-support systems, aerospace equipment, nuclear power control systems, vehicles, disaster/crime-prevention equipment and the like, the failure of which may directly or indirectly cause injury, death or property loss.

■ Anyone purchasing any products described or contained herein for an above-mentioned use shall:

- ① Accept full responsibility and indemnify and defend SANYO ELECTRIC CO., LTD., its affiliates, subsidiaries and distributors and all their officers and employees, jointly and severally, against any and all claims and litigation and all damages, cost and expenses associated with such use:
- ② Not impose any responsibility for any fault or negligence which may be cited in any such claim or litigation on SANYO ELECTRIC CO., LTD., its affiliates, subsidiaries and distributors or any of their officers and employees jointly or severally.

■ Information (including circuit diagrams and circuit parameters) herein is for example only; it is not guaranteed for volume production. SANYO believes information herein is accurate and reliable, but no guarantees are made or implied regarding its use or any infringements of intellectual property rights or other rights of third parties.