

Ceramic Filters (CERAFIL®)/Ceramic Discriminators for Communications Equipment



kHz Type Ceramic Discriminators

Ceramic discriminator consists of wide band piezoelectric resonator.
It is ideal for mobile communication equipments due to its small size and light weight.
Standard line include products for wide range of application, from cordless telecom to cellular telephone, making non-adjustment and shrinking of the detection circuit possible.

■ Features

1. Small in size and light weight.
2. Realize no-adjustment in detection circuit.
3. High sensitivity and stability.
4. Wide range of standard products are available for various ICs.
5. Operating temperature range : -20 to +80 (degree C)
Storage temperature range : -40 to +85 (degree C)

CDBC Series

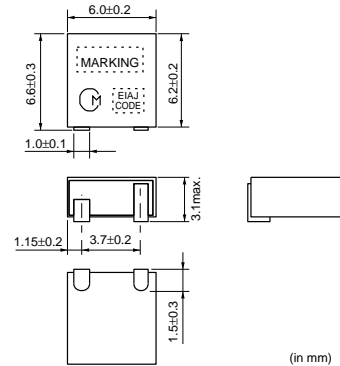

CDBLA Series

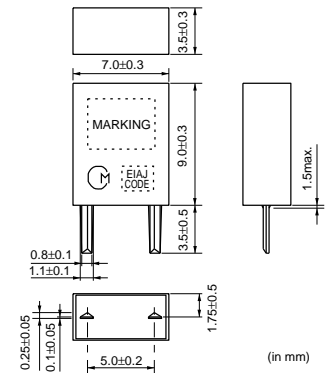

CDBLB_CAX Series

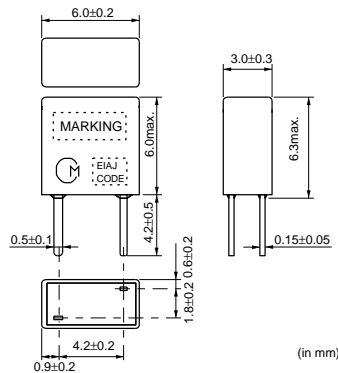

CDBLB_CAY Series

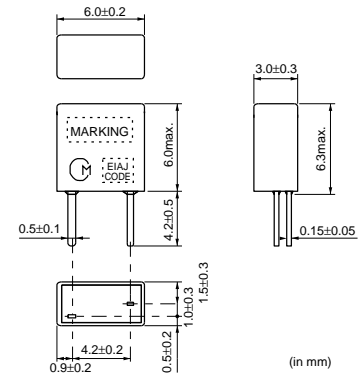

Specified by Impedance Characteristics 1

Part Number	Nominal Center Frequency (fn) (kHz)	Inclination of Impedance Curve(1)	Inclination of Impedance Curve(2)	Capacitance (C)	IC	IC Maker	Type
CDBLB455KCAX02-B0	455	447.0±1.5kHz (at Z =2.05kohm)	463.0±1.5kHz (at Z =10.0kohm)	140pF±20%	TA8104F	TOSHIBA	PLASTIC
CDBLB455KCAX31-B0	455	447.0±1.5kHz (at Z =2.05kohm)	463.0±1.5kHz (at Z =10.0kohm)	140pF±20%	TA31141	TOSHIBA	PLASTIC

Impedance Curve Specification 1

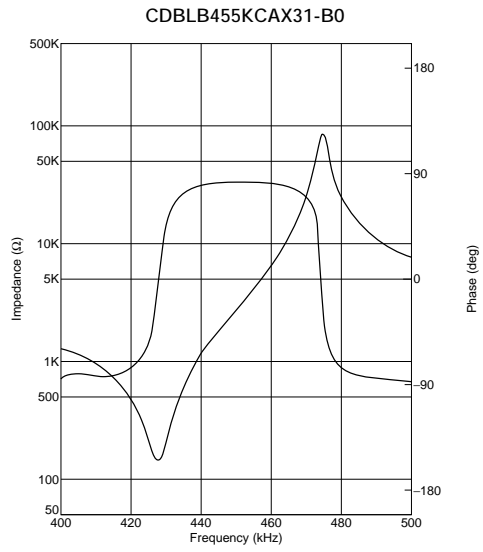
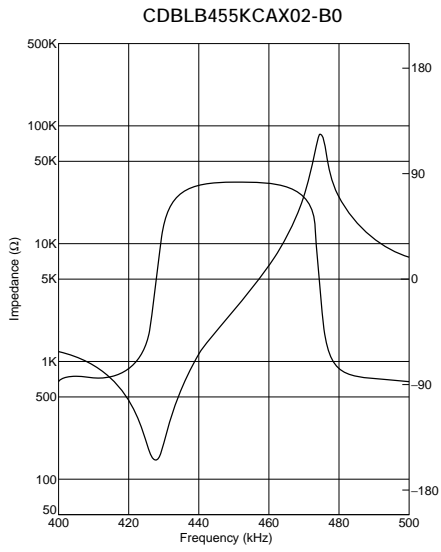

Specified by Impedance Characteristics 2

Part Number	Nominal Center Frequency (fn) (kHz)	Anti-resonant Frequency (Fa)	Delta F (Fa-Fr)	Resonant Resistance (R)	Capacitance (C)	IC	IC Maker	Type
CDBC455KCAX33-R0	-	458.0±1.5kHz	42±4.0kHz	300ohm max.	280pF±20%	CXA1474	SONY	SMD
CDBLA455KCAY03-B0	-	455.0±1.5kHz	48±5.0kHz	70ohm max.	600pF±20%	CXA1184	SONY	PLASTIC
CDBLB455KCAY03-B0	-	455.0±1.5kHz	46±5.0kHz	70ohm max.	550pF±20%	CXA1184M	SONY	PLASTIC
CDBLB455KCAX15-B0	-	463.5±1.0kHz	43±2.0kHz	300ohm max.	140pF±20%	CXA1183M	SONY	PLASTIC
CDBLB455KCAX25-B0	455	465.0±1.5kHz	45±4.0kHz	300ohm max.	135pF±20%	CXA1484	SONY	PLASTIC
CDBLB455KCAX33-B0	455	465.0±1.5kHz	45±4.0kHz	300ohm max.	135pF±20%	CXA1474	SONY	PLASTIC

Impedance Curve Specification 2

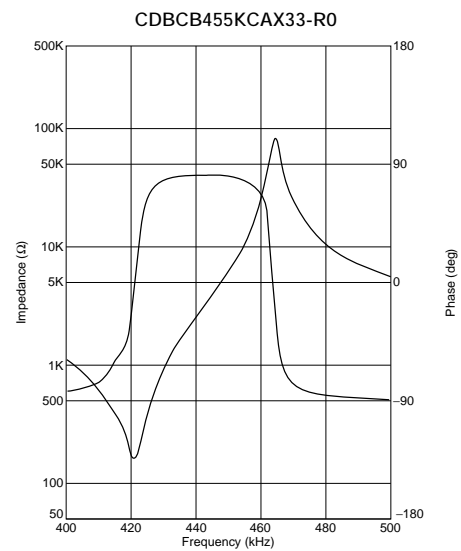
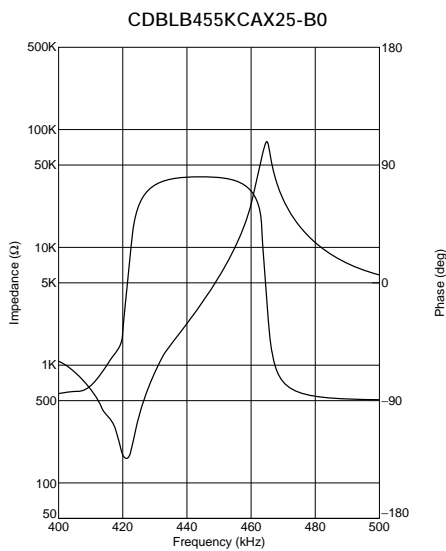
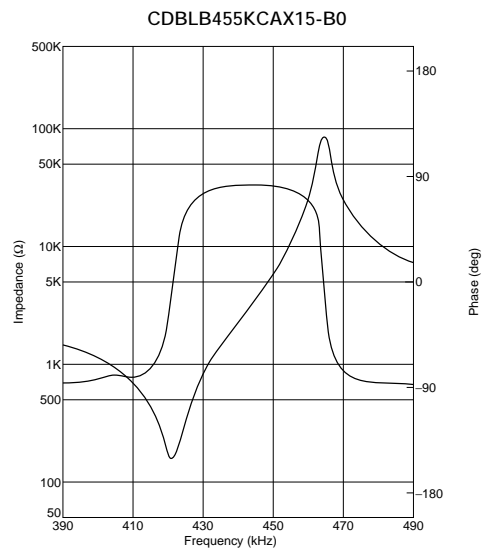
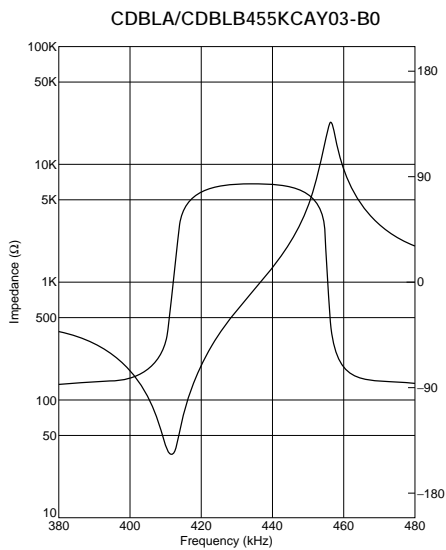

Continued from the preceding page.

Impedance Curve Specification 2

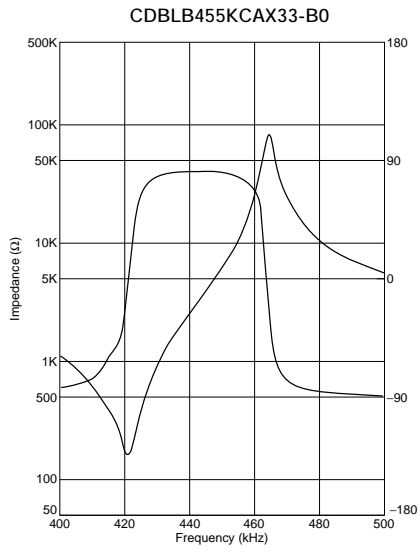

Specified by Recovered Audio Characteristics

Part Number	Nominal Center Frequency (fn) (kHz)	Recovered Audio 3dB BW (kHz)	Recovered Audio Output (mV)	Distortion (at fn) (%)	Distortion (%)	IC	IC Maker	Type
CDBCB455KCAY07-R0	455	fn±4.0 min.	350 ±60	3.0 max.	-	MC3357	MOTOROLA	SMD
CDBCB455KCAY09-R0	455	fn±4.0 min.	120 ±40	1.5 max.	-	NE604N	PHILIPS	SMD
CDBCB455KCAY13-R0	455	fn±4.0 min.	330 ±50	4.0 max.	-	CXA1003BM	SONY	SMD
CDBCB455KCAY16-R0	455	fn±4.0 min.	175 ±40	2.0 max.	-	MC3372	MOTOROLA	SMD
CDBCB455KCAY21-R0	455	fn±4.0 min.	55 ±20	2.0 max.	-	TA31132	TOSHIBA	SMD
CDBCB455KCAY24-R0	455	fn±4.0 min.	100 ±40	2.0 max.	-	TA31136	TOSHIBA	SMD
CDBCB455KCAY27-R0	455	fn±4.0 min.	90 ±30	2.0 max.	-	TK10487	TOKO	SMD
CDBCB455KCAY28-R0	455	fn±4.0 min.	40 ±20	3.0 max.	-	TA31142F	TOSHIBA	SMD
CDBCB455KCAY29-R0	455	fn±4.0 min.	100 ±30	2.5 max.	-	NE605	PHILIPS	SMD
CDBCB455KCAY32-R0	455	fn±4.0 min.	40 ±20	3.0 max.	-	TA31143	TOSHIBA	SMD
CDBCB455KCAY35-R0	455	fn±4.0 min.	100 ±40	2.5 max.	-	TK10930	TOKO	SMD
CDBCB455KCAY40-R0	455	fn±4.0 min.	40 ±20	3.5 max.	-	TA31145	TOSHIBA	SMD
CDBCB455KCAY49-R0	455	fn±4.0 min.	45 ±10	3.0 max.	-	MC3361	MOTOROLA	SMD
CDBCB455KCAY50-R0	455	fn±4.0 min.	64 ±6.4	4.0 max.	-	CXA3117N	SONY	SMD
CDBCB455KCLX36-R0	455	fn±13.0 min.	90 ±30	2.5 max.	5.0 max. [within fn ±6kHz]	NE(SA)606 /NE(SA)616	PHILIPS	SMD
CDBCB455KCLX39-R0	455	fn±11.0 min.	130 ±20	2.5 max.	7.0 max. [within fn ±8kHz]	NE607 /NE617	PHILIPS	SMD
CDBCB455KCLY13-R0	455	fn±13.0 min.	120 ±30	1.5 max.	5.0 max. [within fn ±8kHz]	CXA1003BM	SONY	SMD
CDBCB455KCLY21-R0	455	fn±11.0 min.	75 ±25	2.5 max.	5.0 max. [within fn ±5.5kHz]	TA31132	TOSHIBA	SMD
CDBLA455KCAY07-B0	455	fn±4.0 min.	340 ±60	2.5 max.	-	MC3357	MOTOROLA	PLASTIC
CDBLA455KCAY09-B0	455	fn±5.0 min.	100 min.	1.5 max.	-	NE604N	PHILIPS	PLASTIC
CDBLA455KCAY13A-B0	455	fn±4.0 min.	350 ±50	3.0 max.	-	CXA1003BM	SONY	PLASTIC
CDBLA455KCAY16-B0	455	fn±4.0 min.	185 ±40	2.0 max.	-	MC3372	MOTOROLA	PLASTIC
CDBLA455KCAY24-B0	455	fn±4.0 min.	100 ±40	2.0 max.	-	TA31136	TOSHIBA	PLASTIC
CDBLA455KCAY28-B0	455	fn±4.0 min.	40 ±20	3.0 max.	-	TA31142	TOSHIBA	PLASTIC
CDBLA455KCAY34-B0	455	fn±4.0 min.	65 ±20	2.5 max.	-	MC13136	MOTOROLA	PLASTIC
CDBLA455KCLY09-B0	455	fn±15.0 min.	70 ±20	1.5 max.	3.5 max. [within fn ±8kHz]	NE604N	PHILIPS	PLASTIC
CDBLA455KCLY13-B0	455	fn±15.0 min.	110 ±30	1.5 max.	5.0 max. [within fn ±8kHz]	CXA1003BM	SONY	PLASTIC

Continued on the following page.

Continued from the preceding page.

Part Number	Nominal Center Frequency (fn) (kHz)	Recovered Audio 3dB BW (kHz)	Recovered Audio Output (mV)	Distortion (at fn) (%)	Distortion (%)	IC	IC Maker	Type
CDBLB455KCAY07-B0	455	fn±4.0 min.	340 ±60	3.0 max.	-	MC3357	MOTOROLA	PLASTIC
CDBLB455KCAY13A-B0	455	fn±4.0 min.	350 ±50	3.0 max.	-	CXA1003BM	SONY	PLASTIC
CDBLB455KCAY21-B0	455	fn±4.0 min.	55 ±20	2.0 max.	-	TA31132	TOSHIBA	PLASTIC
CDBLB455KCAY24-B0	455	fn±4.0 min.	100 ±40	2.0 max.	-	TA31136	TOSHIBA	PLASTIC
CDBLB455KCAY28-B0	455	fn±4.0 min.	40 ±20	3.0 max.	-	TA31142FN	TOSHIBA	PLASTIC
CDBLB455KCAY32-B0	455	fn±4.0 min.	40 ±20	3.0 max.	-	TA31143	TOSHIBA	PLASTIC
CDBLB455KCAY34-B0	455	fn±4.0 min.	65 ±20	2.5 max.	-	MC13136	MOTOROLA	PLASTIC
CDBLB455KCAY40-B0	455	fn±4.0 min.	40 ±20	3.0 max.	-	TA31145	TOSHIBA	PLASTIC
CDBLB455KCAY42-B0	455	fn±4.0 min.	40 ±15	3.0 max.	-	TK14590 /TK14591	TOKO	PLASTIC
CDBLB455KCAY49-B0	455	fn±4.0 min.	45 ±10	3.0 max.	-	MC3361	MOTOROLA	PLASTIC
CDBLB455KCAY50-B0	455	fn±4.0 min.	64 ±6.4	4.0 max.	-	CXA3117N	SONY	PLASTIC
CDBLB455KCLY09-B0	455	fn±15.0 min.	70 ±20	1.5 max.	3.5 max. [within fn ±8kHz]	NE604N	PHILIPS	PLASTIC
CDBLB455KCLY13-B0	455	fn±15.0 min.	110 ±30	1.5 max.	5.0 max. [within fn ±8kHz]	CXA1003BM	SONY	PLASTIC
CDBLB455KCLY21-B0	455	fn±13.0 min.	65 ±20	2.5 max.	5.0 max. [within fn ±8kHz]	TA31132	TOSHIBA	PLASTIC
CDBLB455KCAX16-B0	455	fn±4.0 min.	185 ±40	2.0 max.	-	MC3372	MOTOROLA	PLASTIC
CDBLB455KCAX18-B0	455	fn±3.0 min.	180 ±40	2.0 max.	-	MC3371	MOTOROLA	PLASTIC
CDBLB455KCAX36-B0	455	fn±3.5 min.	100 ±25	3.5 max.	-	NE606 /616	PHILIPS	PLASTIC

Test Circuit

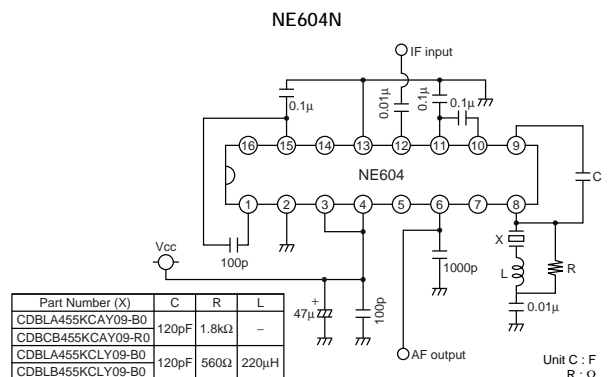
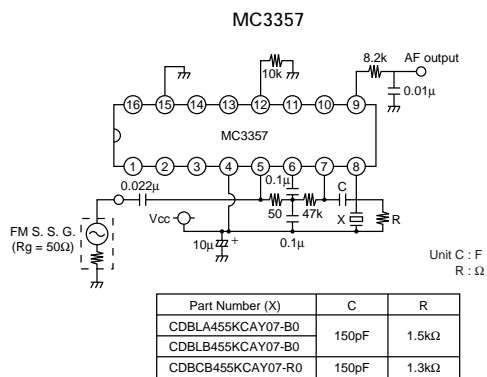

Continued on the following page.

Continued from the preceding page.

Test Circuit

CXA1003BM

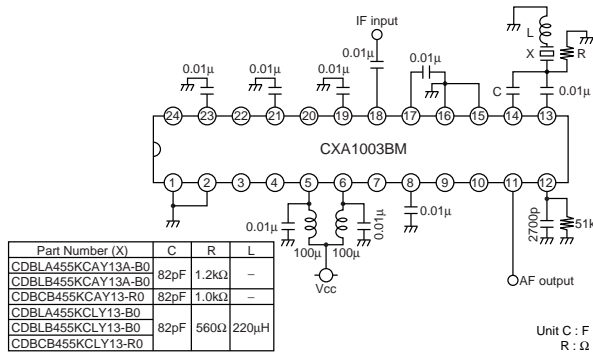

MC3372

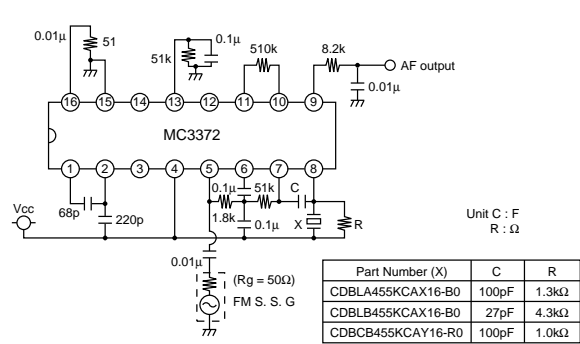

MC3371

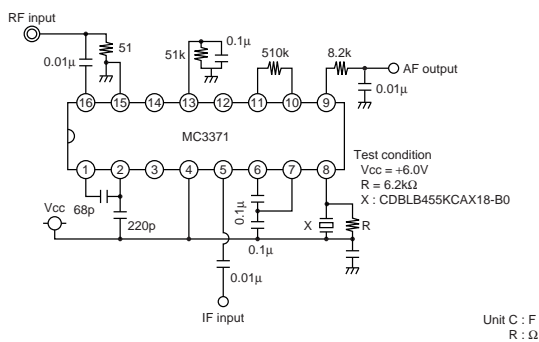

TA31132

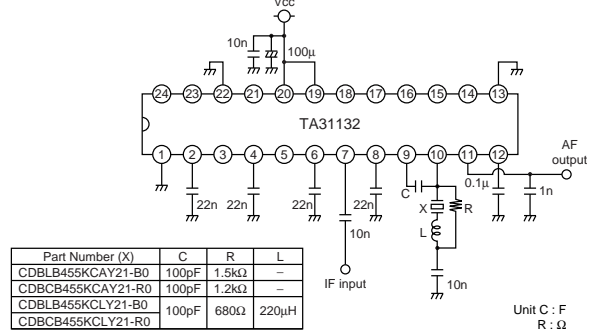

TA31136

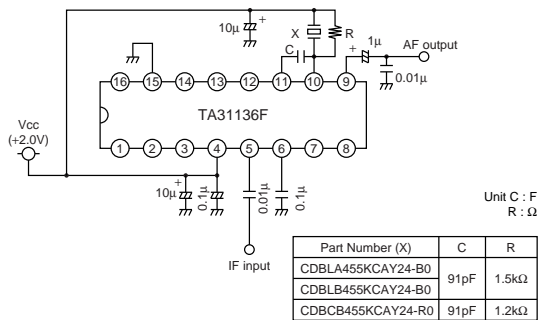

TK10487

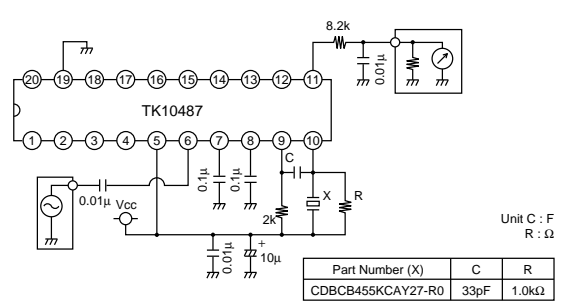

TA31142

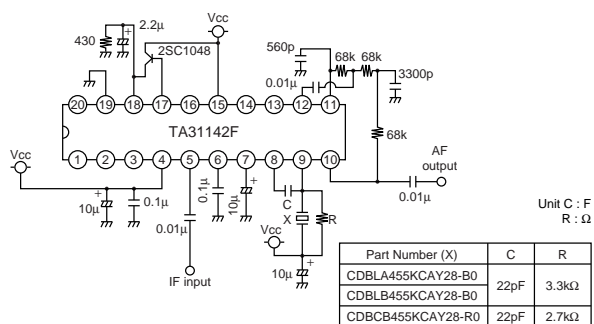

NE605

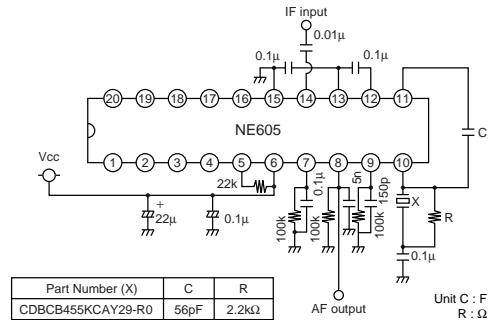

Continued from the preceding page.

Test Circuit

TA31143

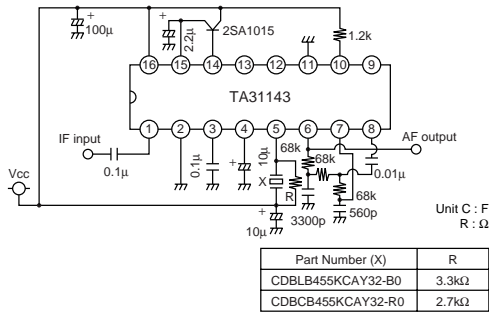

MC13136

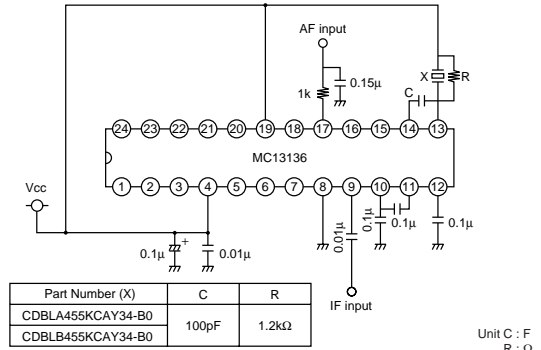

TK10930

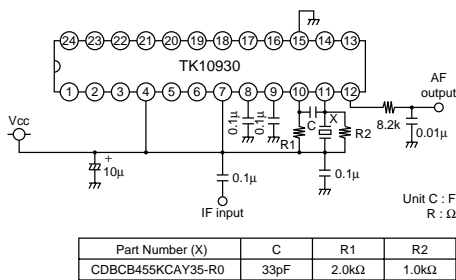

NE(SA)606/616

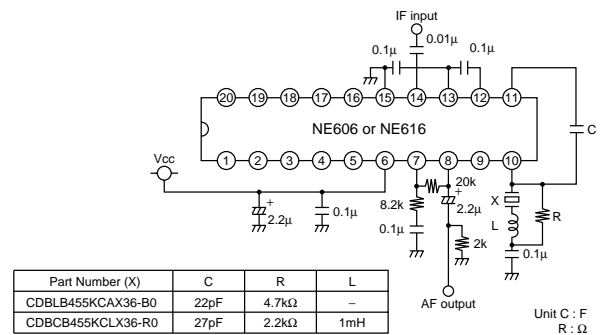

NE(SA)607/617

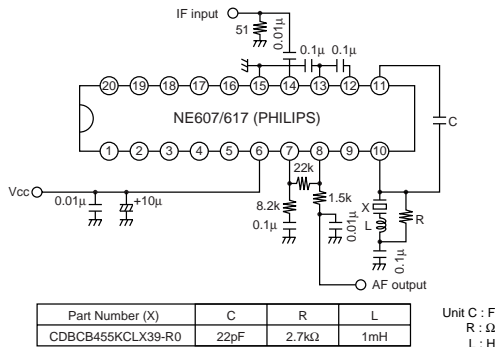

TA31145

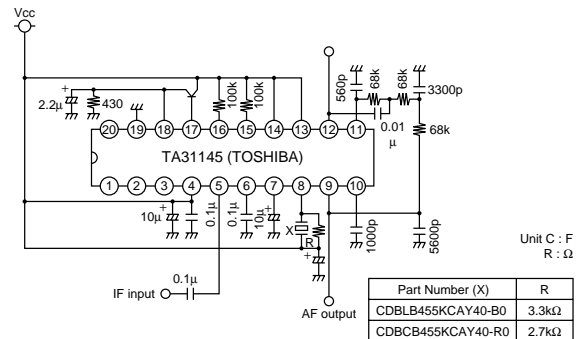

TK14590/14591

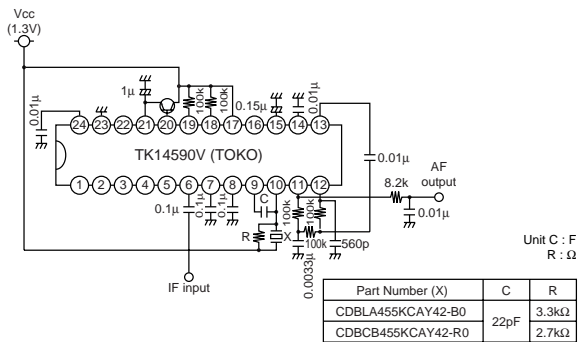

TA31147

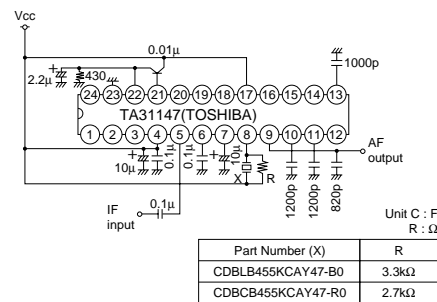

Continued from the preceding page.

Test Circuit

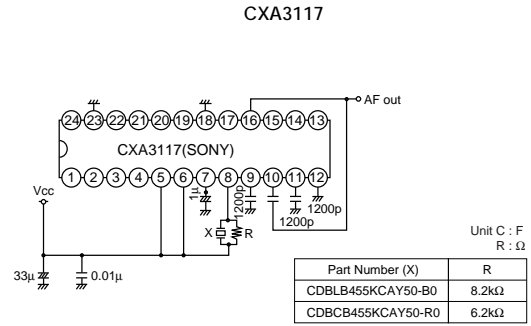
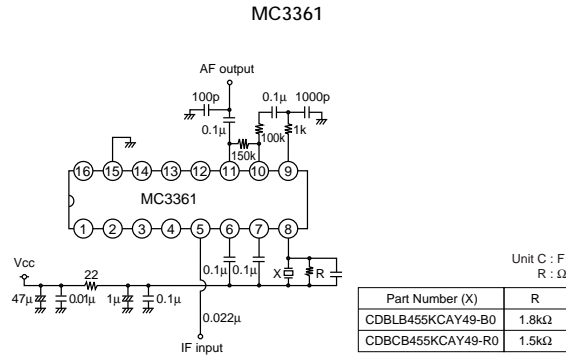

Recovered Audio Curve Specification

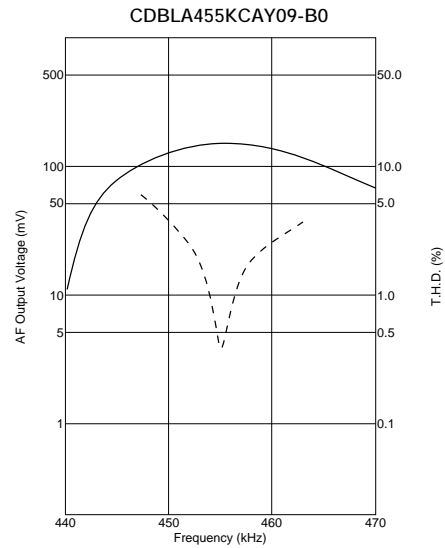
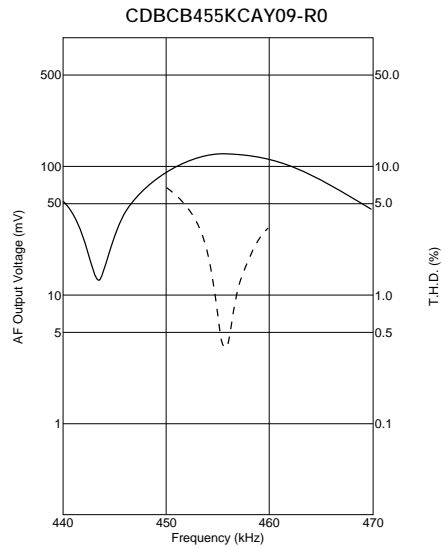
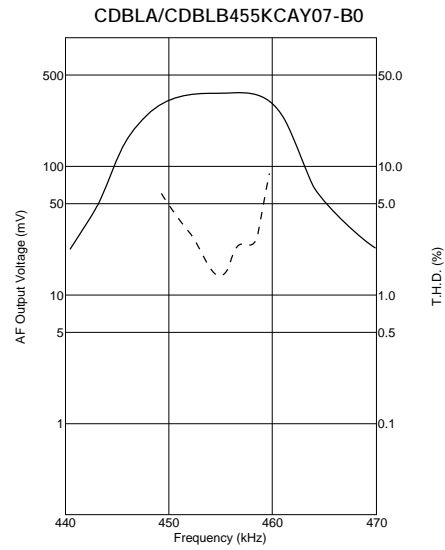
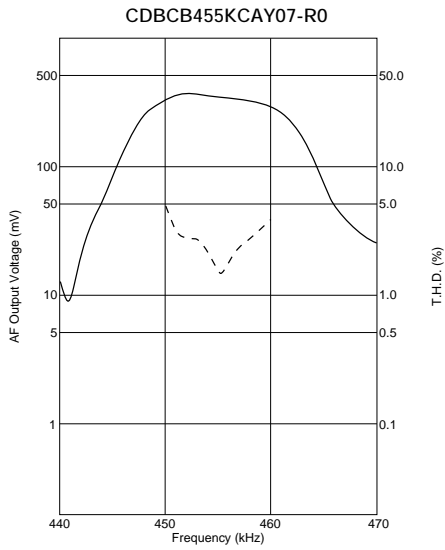

Continued from the preceding page.

Recovered Audio Curve Specification

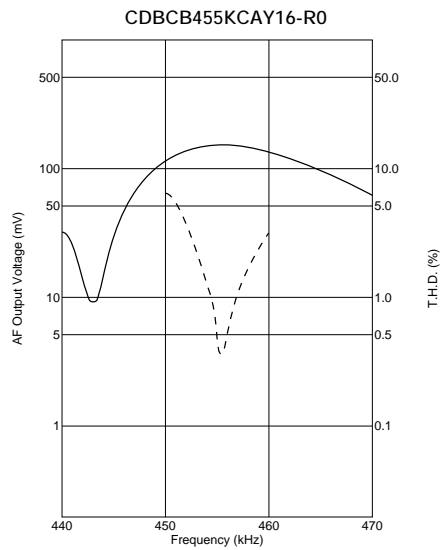
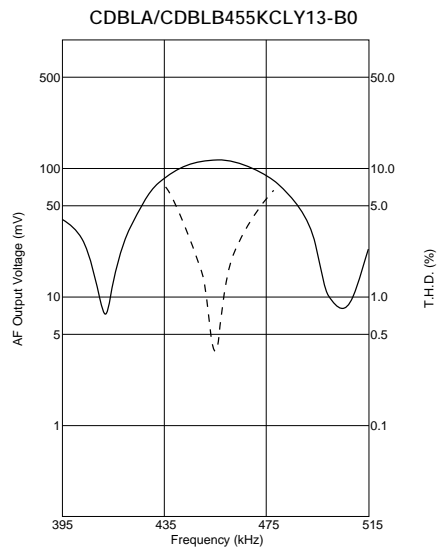
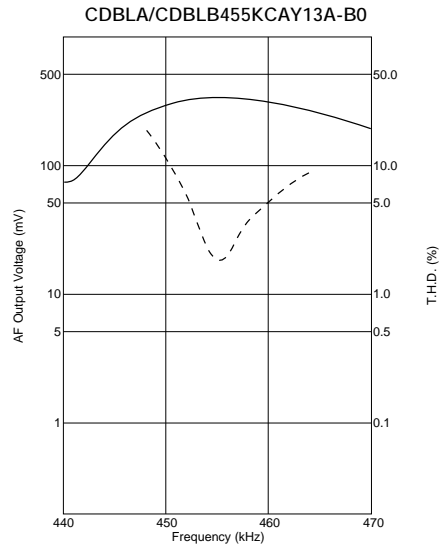
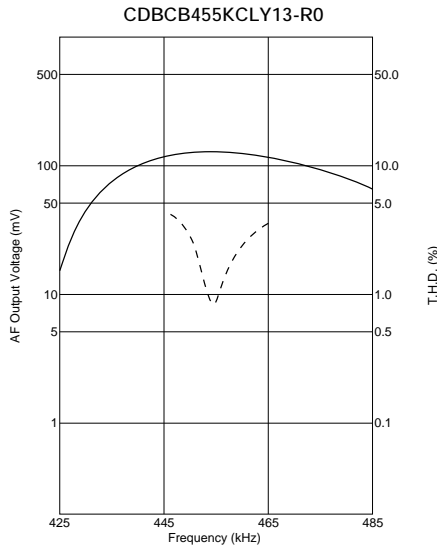
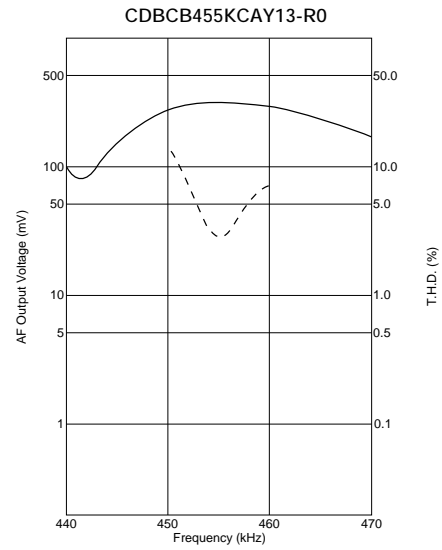
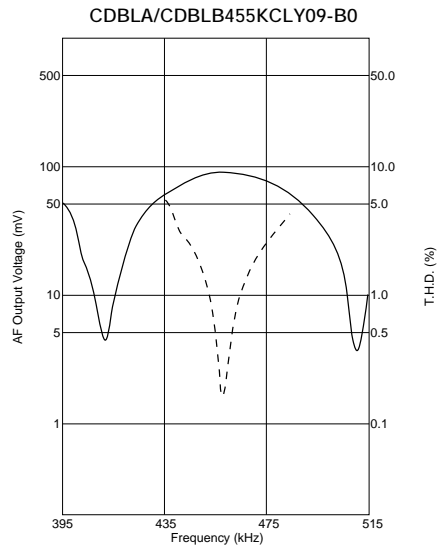

Continued from the preceding page.

Recovered Audio Curve Specification

CDBLA455KCAY16-B0

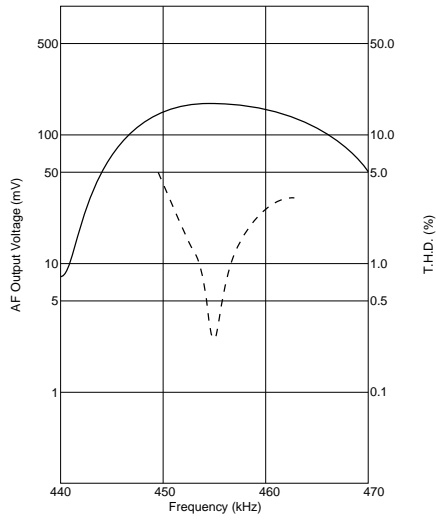

CDBLB455KCAX16-B0

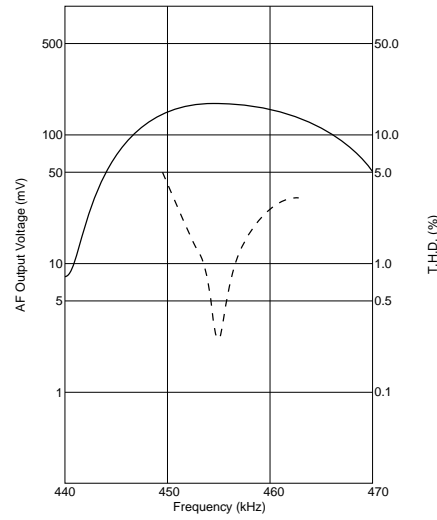

CDBLB455KCAX18-B0

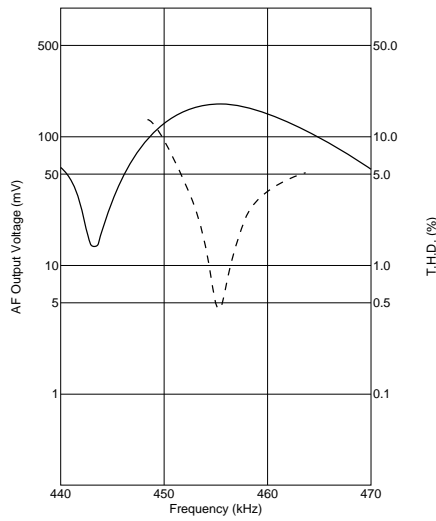

CDBCB455KCAY21-R0

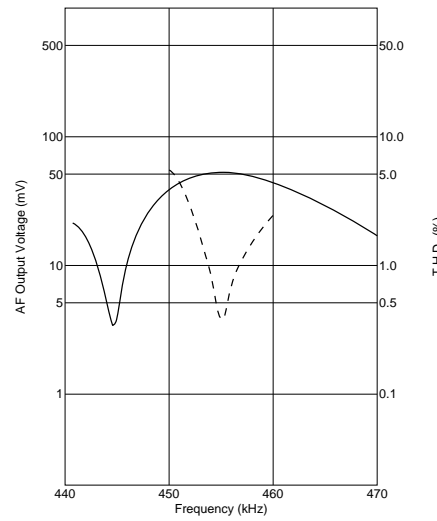

CDBCB455KCLY21-R0

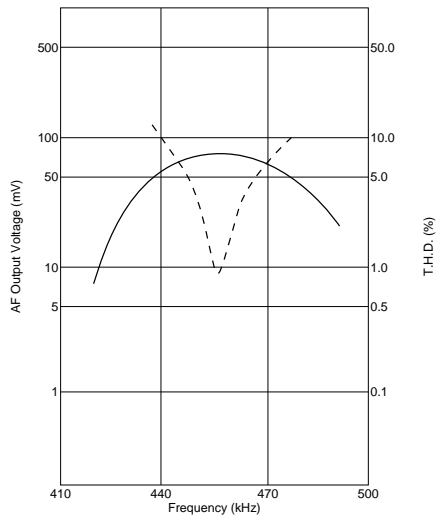

CDBLB455KCAY21-B0

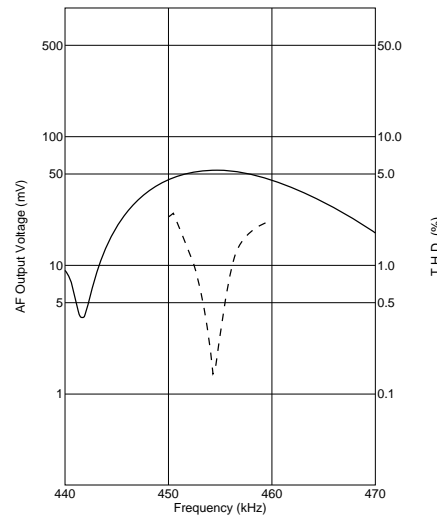

Continued from the preceding page.

Recovered Audio Curve Specification

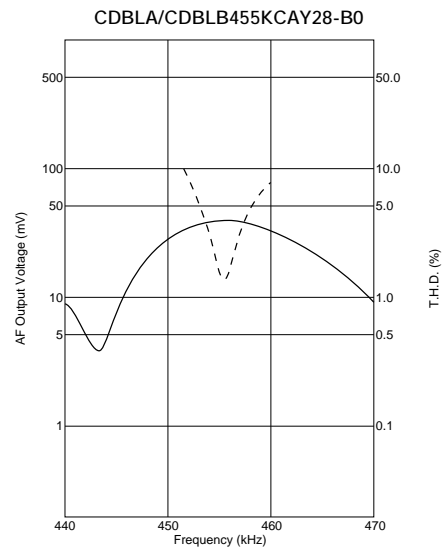
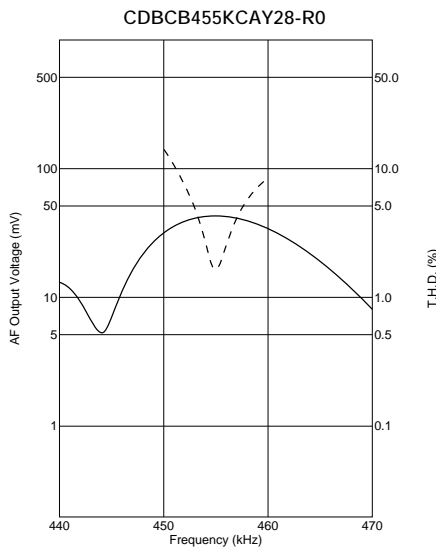
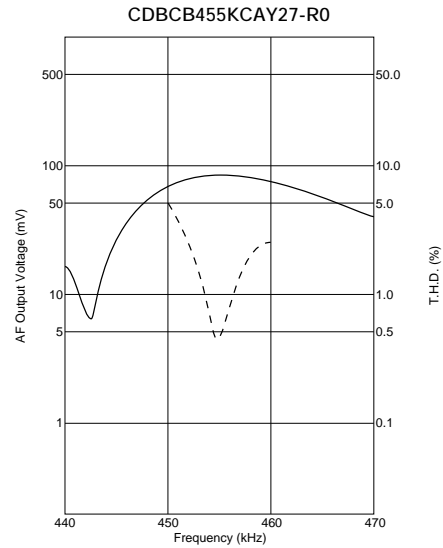
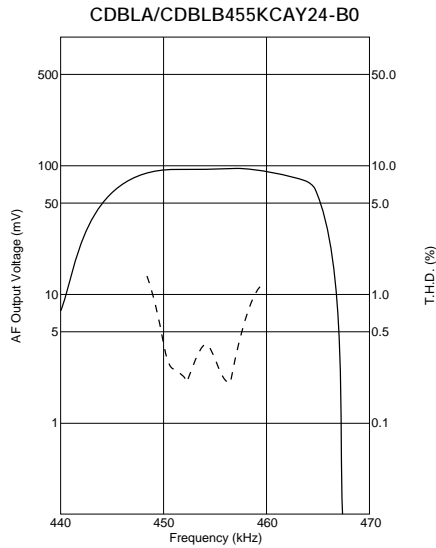
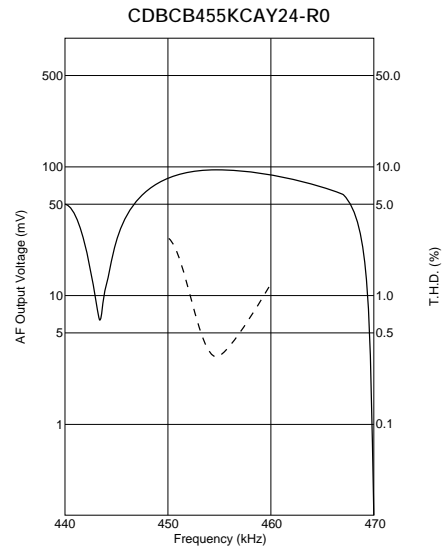
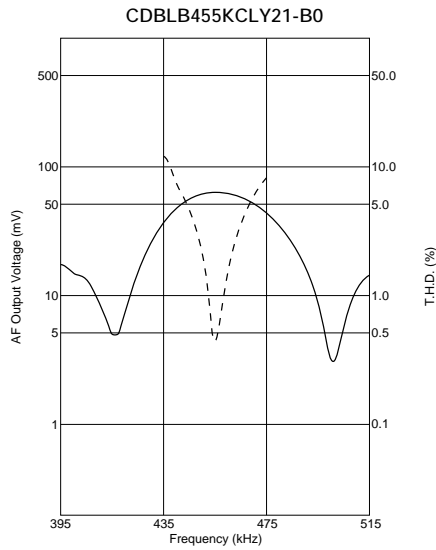

Continued from the preceding page.

Recovered Audio Curve Specification

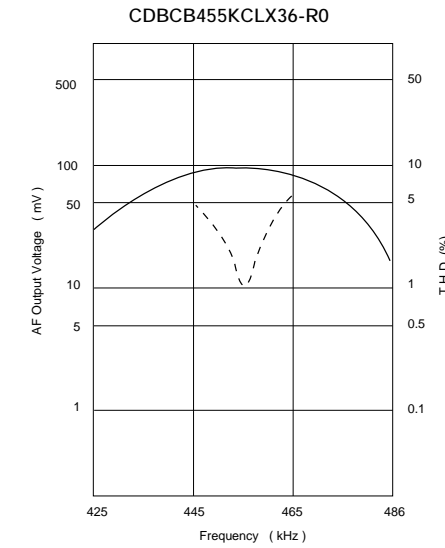
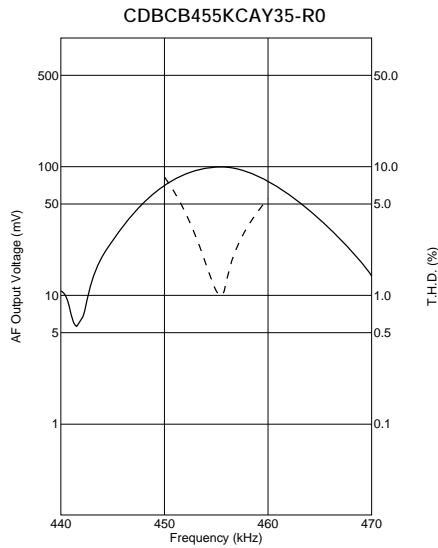
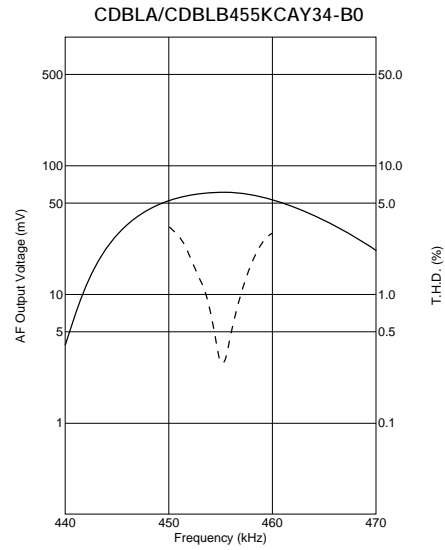
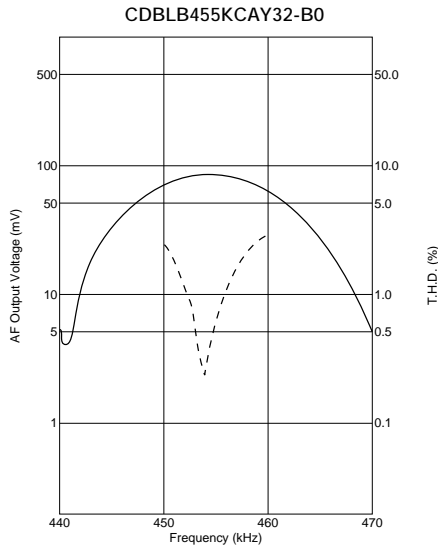
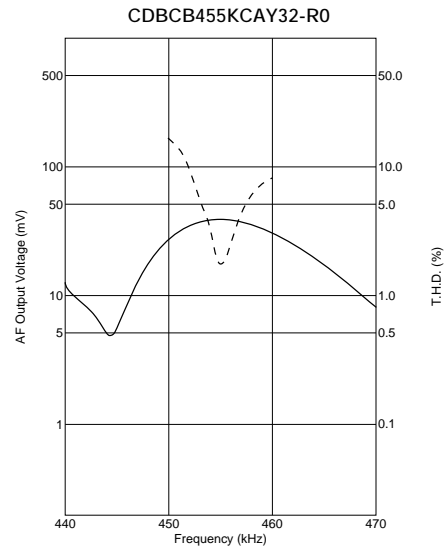
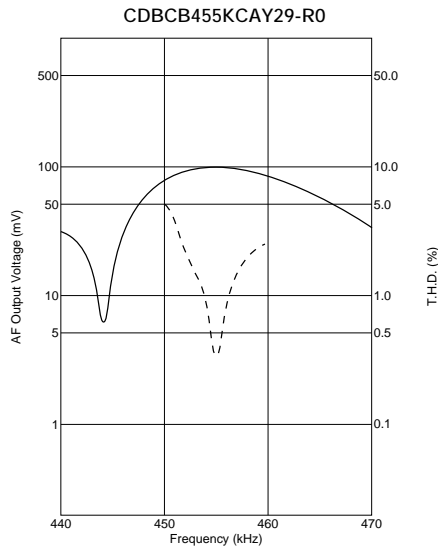

Continued from the preceding page.

Recovered Audio Curve Specification

CDBLB455KCAX36-B0

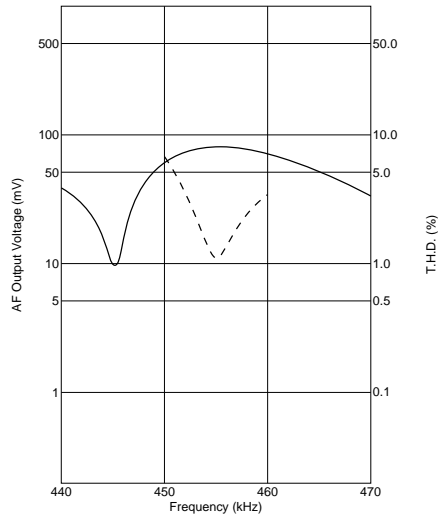

CDBC455KCLX39-R0

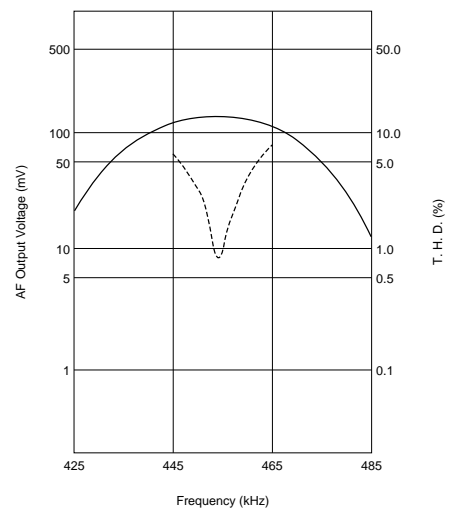

CDBC455KCAY40-R0

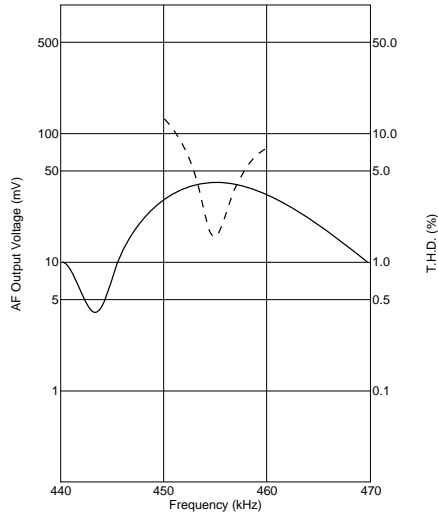

CDBLB455KCAY40-B0

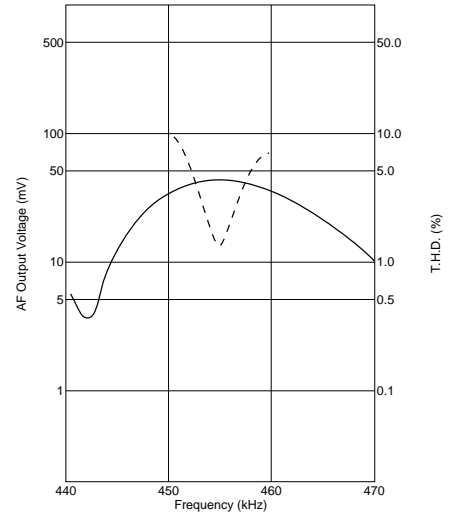

CDBLA/CDBLB455KCAY42-B0

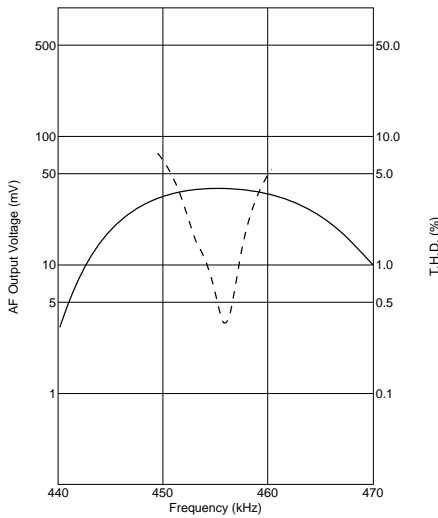

CDBC455KCAY49-R0

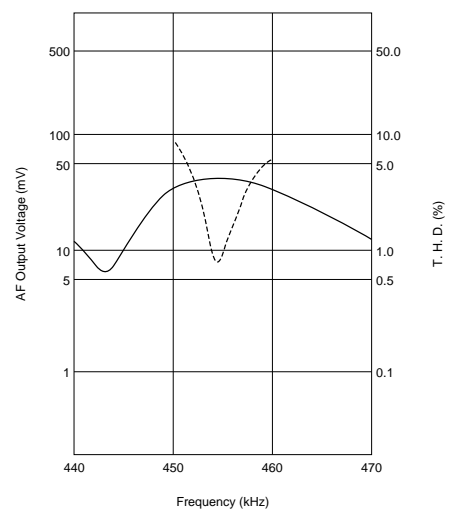

Continued from the preceding page.

Recovered Audio Curve Specification

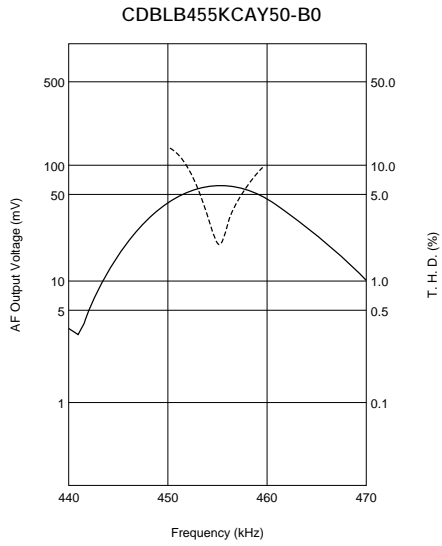
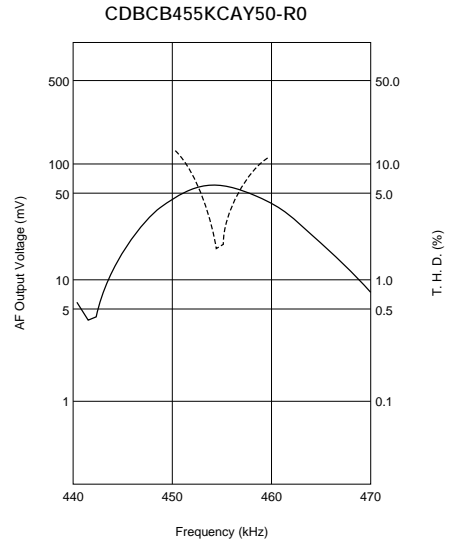
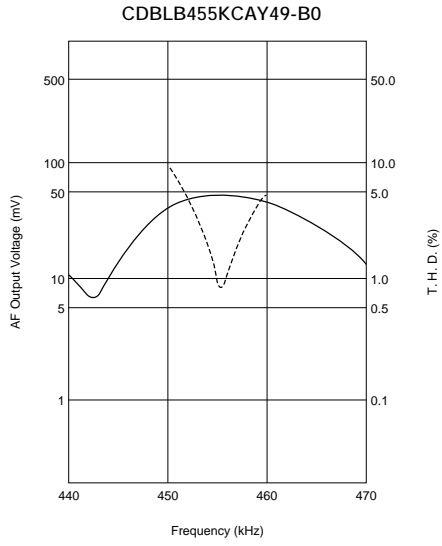

Specified by S Curve Characteristics

Part Number	Nominal Center Frequency (fn) (kHz)	S Curve (1) Output Volt. at fn (mV)	S Curve (2) at fn±4.8kHz (mV)	IC	IC Maker	Type
CDBCB455KCAY47-R0	455	130 ±20	150 ±15	TA31147	TOSHIBA	SMD
CDBCB455KCAY54-R0	455	165 ±20	170 ±20	TA31149	TOSHIBA	SMD
CDBLB455KCAY47-B0	455	140 ±20	150 ±15	TA31147	TOSHIBA	PLASTIC

Test Circuit

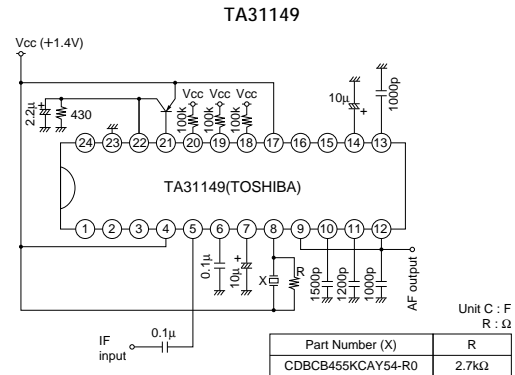
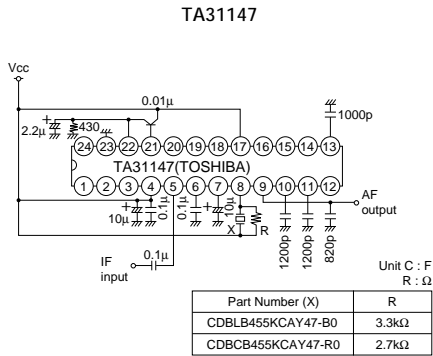

S Curve Specification

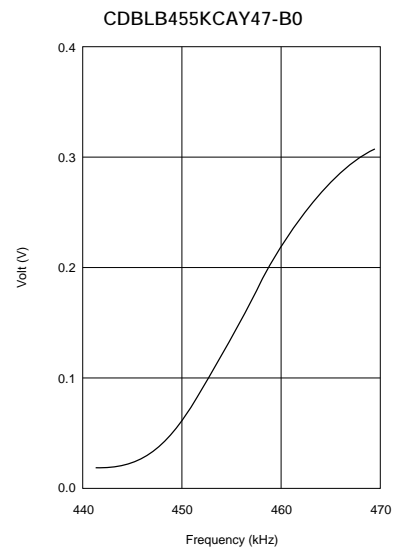
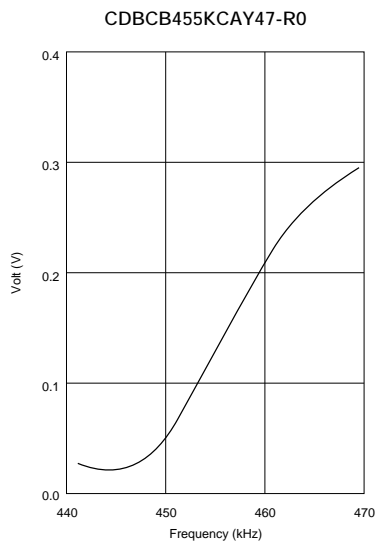

Continued on the following page.

↳ Continued from the preceding page.

■ S Curve Specification

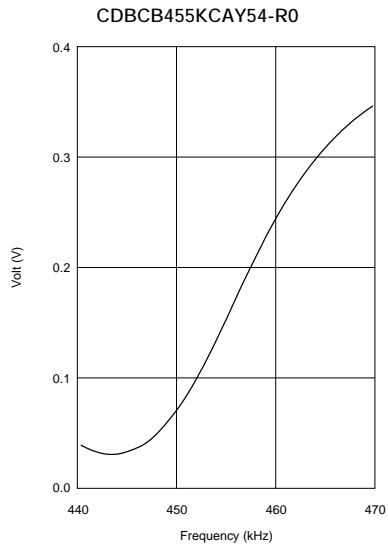

Ceramic Discriminators Notice

■ CDBC Series Notice (Soldering and Mounting)

1. Standard Reflow Soldering Condition

(1) Reflow

Filter is soldered one time within the following temperature condition and then being placed in natural condition for 24 hours.

(2) Soldering Iron

Electrode is directly with the tip of soldering iron of $+350 \pm 5^\circ\text{C}$ for 3 ± 1 seconds, and then being placed in natural condition for 24 hours.

2. Wash

(1) Cleaning Solvent

CFC alternatives(HCFC Series), Isopropyl Alcohol(IPA), Water(Demineralized Water), Cleaning Water Solution(Cleanthrough-750H, Pine Alpha 100S), Silicon(Technocare FRW)

(2) Cleaning Conditions

- Immersion Wash
2 minutes max. in above solvent at $+60^\circ\text{C}$ max.
- Shower or Rinse Wash
2 minutes max. in above solvent at $+60^\circ\text{C}$ max.

(3) Notice

- When components are immersed in solvent, be sure to maintain the temperature of components below the temperature of solvent.
- Please do not use ultrasonic cleaning.
- Total washing time should be within 4 minutes.
- Please ensure the component is thoroughly evaluated in your application circuit.
- Please do not use chlorine, petroleum and alkali cleaning solvent.
- If you plan to use any other type of solvents, please consult with Murata or MURata representative prior to using.

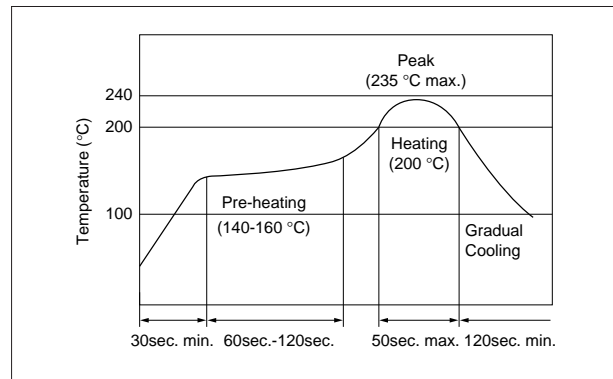

Continued on the following page. 

Ceramic Discriminators Notice

☒ Continued from the preceding page.

■ CDSCA Series Notice (Soldering and Mounting)

1. Standard Reflow Soldering Condition

(1) Reflow

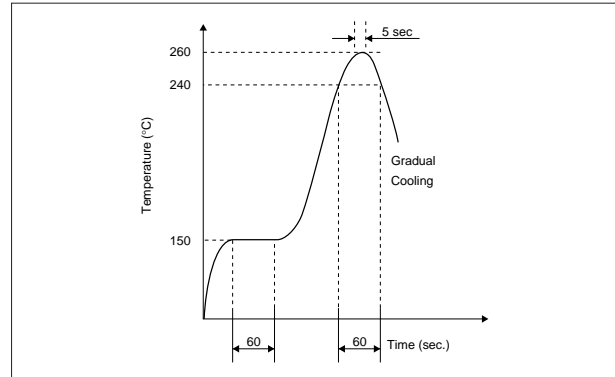

(2) Soldering Iron

Lead terminal is directly contacted with the tip of soldering iron of $+280 \pm 5^\circ\text{C}$ for $3.0 \text{ seconds} \pm 0.5 \text{ seconds}$.

2. Wash

The component cannot be withstand washing.

Ceramic Discriminators Notice

■ CDBC Series Notice (Handling)

1. The component will be damaged when an excessive stress is applied.
2. In the case that the component is cleaned, confirm no reliability degradation is created.
3. In case of covering filter with over coat, conditions such as material of resin, cure temperature, and so on should be evaluated well.
4. Do not use strong acidity flux, more than 0.2wt% chlorine content, in re-flow soldering.

■ CDBLA/CDBLB Series Notice (Handling)

1. Do not use this product with bend. The component may be damaged if excess mechanical stress is applied to it mounted on the printed circuit board.
2. The component will be damaged when an excessive stress is applied.
3. All kinds of re-flow soldering must not be applied on the component.

■ CDSCA Series Notice (Handling)

1. The component mounted on the PCB may be damaged if excess mechanical stress is applied.
2. Layout the components on the PCB to minimize the stress imposed by the warp or flexure of the board.
3. After installing components, if solder is excessively applied to the circuit board, mechanical stress will cause destruction resistance characteristics to be lower. To prevent this, be extremely careful in determining shape and dimension before designing the circuit board diagram.
4. When the positioning claw or pick up nozzle are worn, the excess load is applied to the components while positioning or placing are performed. Careful checking and maintenance are necessary to prevent unexpected trouble.
5. When correcting component's position with a soldering iron, the tip of the soldering iron should not directly touch the chip component. Depending on the soldering conditions, the effective area of terminations may be reduced. The use of solder containing Ag should be considered to prevent the electrode erosion.
6. Do not clean or wash the component as it is not hermetically sealed.
7. In case of overcoating the part, coating conditions such as material, curing temperature, and so on must be evaluated deeply.
8. Accurate test circuit values are required to measure electrical characteristics.
It may be a cause of mis-correlation if there is any deviation, especially stray capacitance, from the test circuit in the specification.

5. The product, packed in the moisture-proof bag (dry pack), is sensitive to moisture.
The following treatment is required before applying re-flow soldering, to avoid package cracks or reliability degradation caused by thermal stress.
When unpacked, store the component in an atmosphere of below 25C. and below 65%R.H., and solder within 48 hours.

4. Do not clean or wash the component as it is not hermetically sealed.
5. Do not use strong acidity flux, more than 0.2wt% chlorine content, in flow soldering.
6. In case of covering discriminator with over coat, conditions such as material of resin, cure temperature, and so on should be evaluated well.

