

# M56755FP

SPINDLE MOTOR DRIVER

## DESCRIPTION

The M56755FP is a semiconductor integrated circuit designed for a single chip controller for CD-ROM spindle motor.

M56755FP has a both (forward and reverse) motor torque control by the motor speed control terminal.

M56755FP has the several braking mode that an user can flexibly select in order to generate the reverse torque. Also, this device includes a bias circuit for Hall Sensor, a current limit circuit and a thermal shut down function.

## FEATURES

- The supply voltage with wide range.  
(4.5V to 13.2V)
- High motor drive current (1.2A)
- Motor current control for the both motor torque is possible.
- Reverse torque mode select (SHORT BRAKING, etc)
- Sleep mode
- Hall amplifier sensitivity select
- Automatic stop select (with reverse detected signal pin)

## APPLICATION

CD-ROM, DVD, DVD-ROM etc.

## PIN CONFIGURATION (TOP VIEW)

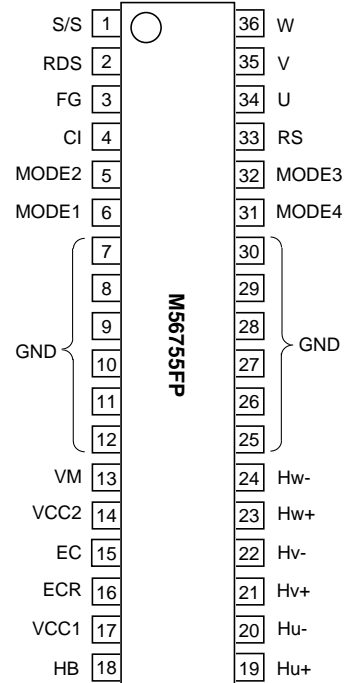

Outline 36P2R-D

## BLOCK DIAGRAM

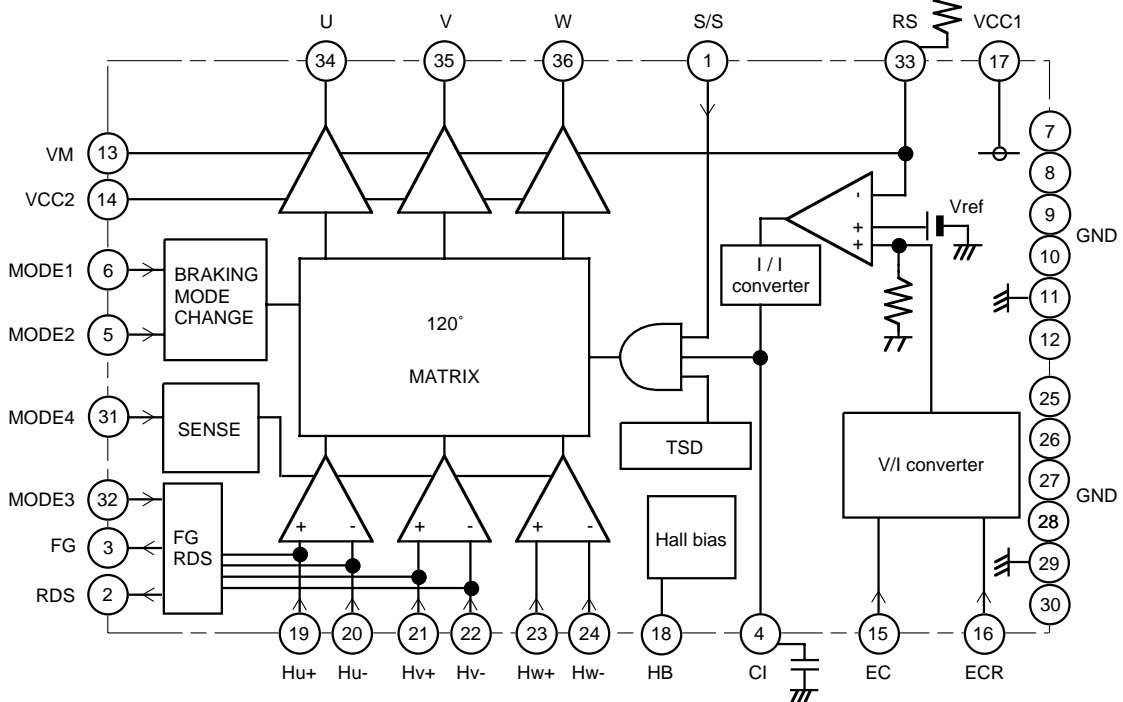

**PIN DESCRIPTION**

Pin No.	Symbol	Function
①	S/S	Start / Stop
②	RDS	Reverse detected signal
③	FG	Frequency generator output
④	CI	Phase Compensation
⑤	MODE2	Reverse torque mode select 2
⑥	MODE1	Reverse torque mode select 1
⑦ to ⑫	GND	GND
⑬	VM	Motor supply voltage
⑭	VCC2	12V supply voltage
⑮	EC	Motor speed control
⑯	ECR	The reference voltage for EC
⑰	VCC1	5V supply voltage
⑱	HB	Bias for Hall Sensor
⑲	Hu+	Hu+ Sensor amp. input
⑳	Hu-	Hu- Sensor amp. input
㉑	Hv+	Hv+ Sensor amp. input
㉒	Hv-	Hv- Sensor amp. input
㉓	Hw+	Hw+ Sensor amp. input
㉔	Hw-	Hw- Sensor amp. input
㉕ to ㉚	GND	GND
㉛	MODE4	Hall amplifier sensitivity select
㉜	MODE3	Automatic stop select
㉝	RS	Motor current sense
㉞	U	Motor drive output U
㉟	V	Motor drive output V
㊱	W	Motor drive output W

\* The ②pin[RDS] and ③pin[FG] are with pull-up resistor (10kohm).

**ABSOLUTE MAXIMUM RATING (Ta=25°C)**

Symbol	Parameter	Conditions	Rating	Unit
VM	Motor supply voltage	⑬pin maximum input voltage	16	V
VCC2	12V supply voltage	⑭pin maximum input voltage	16	V
VCC1	5V supply voltage	⑰pin maximum input voltage	7.0	V
Io	Output current	*Note 1	1.5	A
VH(c)	Sensor amp. Differential input range	⑲ to ㉔ pins	4.5	V
Pt	Power dissipation	Free Air	1.2	W
Kθ	Thermal derating	Free Air	9.6	mW/°C
Tj	Junction temperature		150	°C
Topr	Operating temperature		-20 – +75	°C
Tstg	Storage temperature		-40 – +125	°C

\*Note1 ; There is no overing Pt (power dissipation) or the area of safety operation

**RECOMMENDED OPERATING CONDITIONS**

Symbol	Parameter	Limits			Unit
		Min.	Typ.	Max.	
VCC1	5V Power supply	4.5	5.0	5.5	V
VCC2	12V Power supply	4.5	12.0	13.2	V
VM	Motor Power supply	4.5	12.0	13.2	V
Io	Output drive current	—	—	700	mA

**ELECTRICAL CHARACTERISTICS (VCC=5V, VCC2=12V, VM=12V, Ta=25°C unless otherwise noted)**

Symbol	Parameter	Test conditions	Limits			Unit	
			Min.	Typ.	Max.		
Icc1	Sleep Mode Supply current-1	⑬ and ⑭ pin total Input Current [① pin Io or open]	—	0	100	μA	
Icc2	Sleep Mode Supply current-2	⑰ pin Input Current [① pin Io or open]	—	—	500	μA	
Icc3	Supply current-3	⑰ pin Input Current (EC=ECR=2.5V) [① pin Hi]	—	—	6.0	mA	
Vsat	Saturation voltage	Top and Bottom saturation voltage. Load current 500mA	—	1.2	1.9	V	
ECdead-	Control voltage dead zone	EC < ECR	-50	-25	-5	mV	
ECdead+		EC > ECR	+5	+25	+50		
ECR	Reference voltage Input range	⑮ pin Input voltage range. (3.3V DSP available)	0.5	1.65	4.0	V	
EC	Control voltage Input range	⑮ pin Input voltage range. (3.3V DSP available)	0.5	1.65	4.0	V	
Gio	Control gain	Io = Gio / Rsense [A/V]	1.95	2.3	2.65	V/V	
Vlim	Control limit	Ilim = Vlim / Rsense [A]	0.27	0.3	0.33	V	
VH com	Hall sensor amp common mode input range	⑲ – ⑳ pins input range.	1.2	—	4.5	V	
VHmin1	Hall sensor amp. input signal level	⑲ – ⑳ pins input signal	MODE4 = open	50	—	—	mVp-p
VHmin2			MODE4 = GND	35	—	—	
VHb	Hall bias terminal output voltage	Load current (IHb) 10mA.	0.6	0.85	1.2	V	
IHb	Hall bias terminal sink current		—	—	30	mA	
Von	Motor start voltage	① pin input voltage when makes the motor start up. *The ICs will be the active condition. *The hall bias will be available.	2.0	—	—	V	
Voff	Motor stop voltage	① pin input voltage when makes the motor stop. *The ICs will be the sleep condition. *The hall bias will be off.	—	—	0.8	V	
ViH	mode pin input high voltage	⑥ pin [MODE1], ⑤ pin [MODE2], ⑳ pin [MODE3] and ⑳ pin [MODE4] input voltage when makes high level.	2.0	—	—	V	
ViL	mode pin input low voltage	⑥ pin [MODE1], ⑤ pin [MODE2], ⑳ pin [MODE3] and ⑳ pin [MODE4] input voltage when makes low level.	—	—	0.8	V	
VOL	② pin [RDS], ③ pin [FG] output low voltage	at Io current = 1mA	—	—	0.5	V	

**ELECTRICAL CHARACTERISTICS** (VCC=5V, VM=12V, Ta=25°C, Unless otherwise noted.)

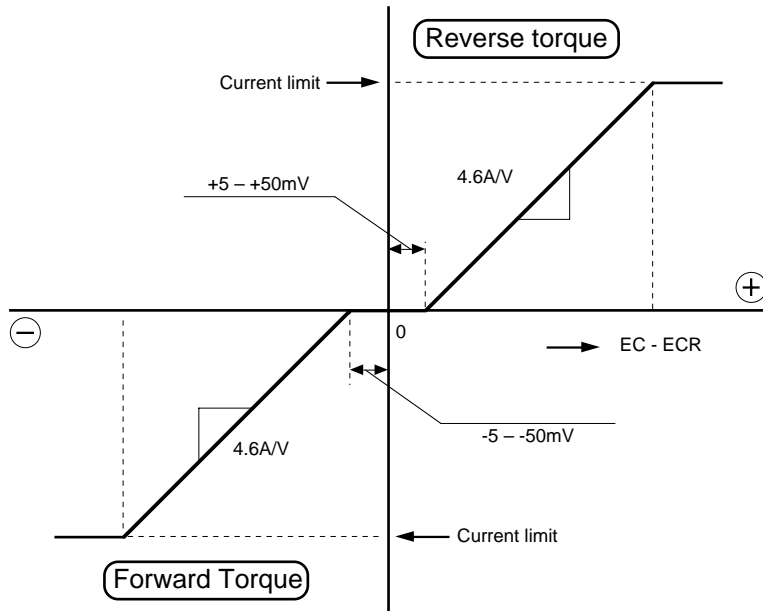

The relationship between the EC (control voltage), ECR (reference voltage) and the torque is as shown in Figure 1. The current gain is 4.6A/V (at sensing resistor : 0.5ohm) in the both torques and a dead zone is  $\pm 5\text{mV}$  to  $\pm 50\text{mV}$ .

**Figure 1. The characteristics of the control voltage and motor current (Torque).**

**HALL AMPLIFIER INPUT AND COMMUTATION**

The relationship between the hall amplifier inputs voltage and the motor current outputs is as shown in Figure 2.

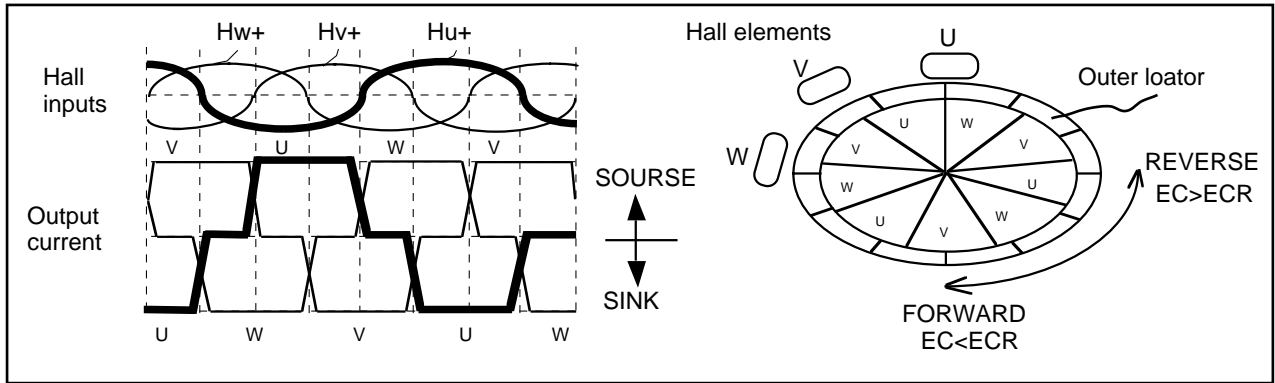

Figure 2.

**HALL AMPLIFIER INPUT SENSITIVITY SELECT**

MODE4	
OPEN or HIGH	GND
120 degree soft switching	120 degree switching ** to current will be shape.
The hall amp input voltage minimum is 50mVp-p.	The hall amp input voltage minimum is 35mVp-p.

Figure 3.

Figure 3 shows the hall amplifier input sensitivity select function. An user is able to select the sensitivity of a hall amplifier to match with the hall elements type.

If the output minimum level of a hall elements is a low level as below 50mVp-p, please connect the MODE4 to GND at external. In this case, the output current will be shape. If the output minimum level of a hall elements is more higher than 50mVp-p, please make the MODE4 to open, then the output current will be commutated softly. We recommend that the output level of a hall element is used for 80mVp-p to 120mVp-p and the MODE4 is made to open.

**SLEEP MODE FUNCTION**

START / STOP	
LOW or OPEN	HIGH
Motor Stop	Motor on
Bias off	Bias on
Hall-Bias off	Hall-Bias on

Figure 4.

Figure 4 shows the sleep mode function. If the 1pin [S/S] is set to open or low, the current output will be high impedance and then the motor will be stop. Also, the IC bias current will be a slight current (please make reference the electrical characteristics). At the same time, the hall bias output will be cut off. When the 1pin goes high, the all of circuits will be available.

**FORWARD AND REVERSE ROTATION DETECT**

Figure 5 shows the circuits and function of the forward and reverse rotation detect.

The RDS is the output signal pin that detected by the signal of hall inputs (Hu+,Hu-,Hv+ and Hv-). The RDS pin is pulled-up to VCC1 by internal resistor (typ. 10kohm). When the motor is spinning at forward, the RDS pin output will be a low level. When the rotation of motor is reversed at stop mode, it will be a high level.

**AUTOMATICLY STOP AFTER REVERSE BRAKING**

Figure 5 shows the automaticly stop circuits after the reverse braking, too. Figure 6 shows its function table. The MODE3 is the input pin in order to be selected either the automaticly stop or non-stop. When the MODE3 is open, the motor rotation will be stopped automaticly after the reverse braking in order to make stop the motor. When the MODE3 is connected to GND, the motor will continue the reversed rotation. This mode [MODE3=GND] is available for the case that an user hope to control the motor stopping at external.

**FG FUNCTION**

Figure 5 shows the circuits and function of the frequency generator, too. The FG is the pin that output the signal synchronize with the hall inputs [Hv+ and Hv-] timing.

The FG pin is pulled-up to VCC1 by internal resistor [typ.10Kohm].

MODE3	
OPEN or HIGH	GND
AUTOMATIC STOP	UN-AUTOMATIC (NON-STOP)

Figure 6.

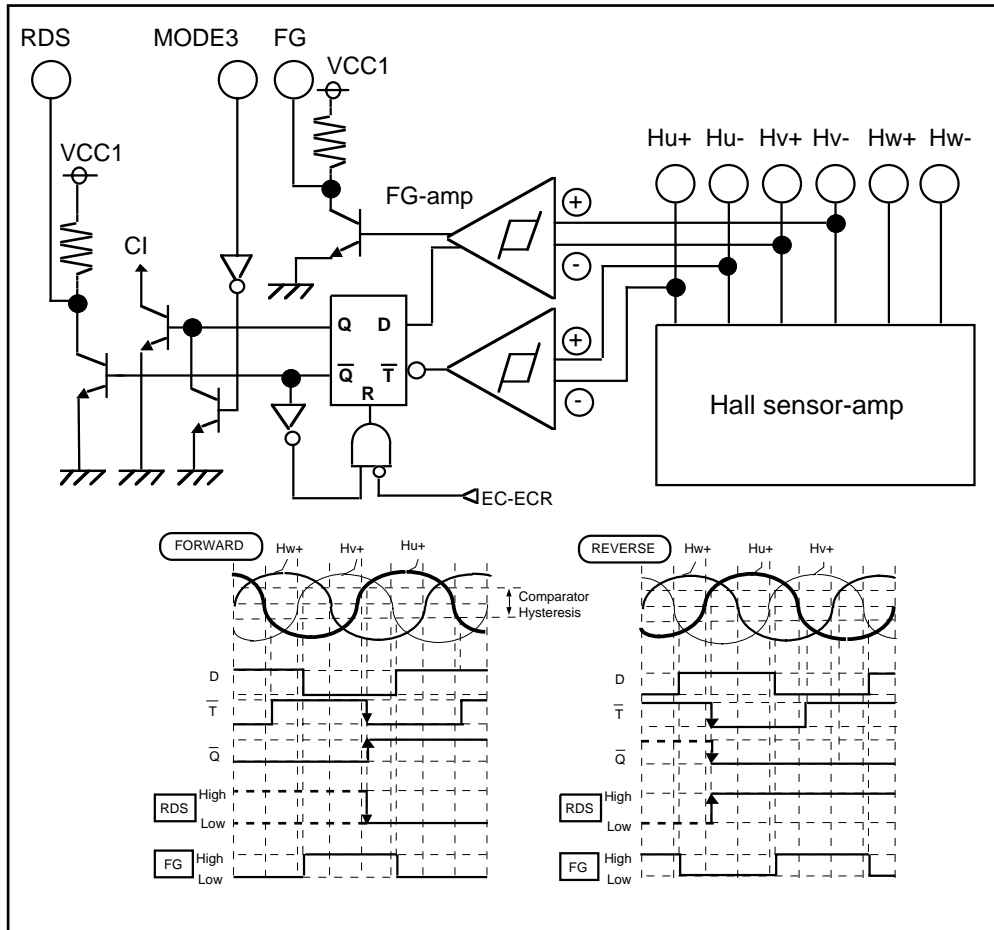

Figure 5.

# M56755FP

## SPINDLE MOTOR DRIVER

### REVERSE TORQUE MODE SELECT FUNCTION

At the 4 times speed and the 6 times speed CDROM drive system, the reverse braking style has been used for the reverse torque. However, at the 8 times speed CDROM drive system, the motor current will be needed above 0.7A, if an user of driver IC require a high speed access time.

If the reverse braking is used at 0.7A, the IC junction temperature will be too much high.

Therefore, MITSUBISHI new motor driver has the braking mode select function. This mode select function is available in order to

control flexibly in match with the situation of junction temperature. Figure 7 shows the reverse torque mode select function table. If you hope original(the reverse braking) style, please only select REVERSE BRAKING mode [MODE1=LOW or OPEN and MODE2 =HIGH] at external. If it is possible to get two more port from  $\mu$ com, you can flexibly control the four kinds of BRAKING MODE. If you can only get one more port, you can control only the MODE2. Then, you can control the two kinds of BRAKING MODE [commutated short or reverse] under the MODE1 is set to LOW or OPEN.

		MODE1	
		LOW or OPEN	HIGH
MODE2	LOW or OPEN	COMMUTATED SHORT BRAKING	ALL SHORT BRAKING
	HIGH	REVERSE BRAKING	OUTPUT OPEN [only inertia]

Figure 7.

Figure 8 shows an example for the reverse torque mode select.

The CASE1 is an controlling example for REVERSE and COMMUTATED SHORT BRAKING.

The CASE2 is an controlling example for REVERSE and ALL SHORT BRAKING.

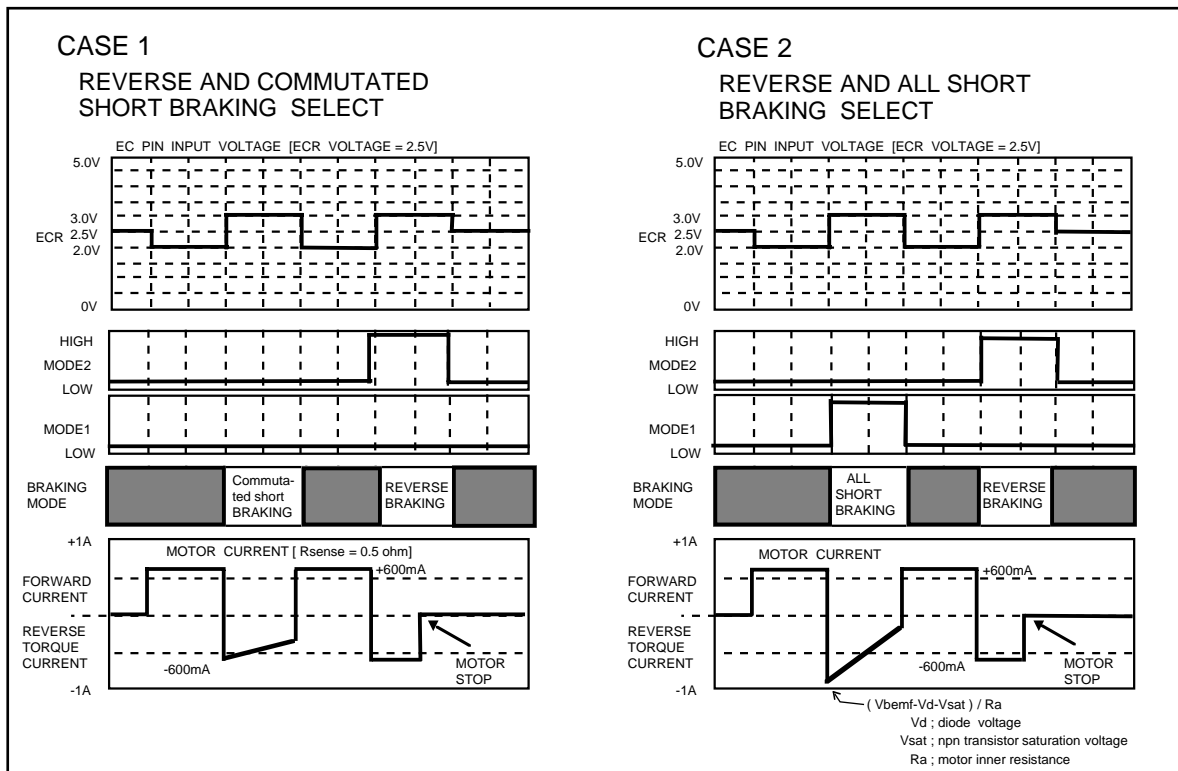
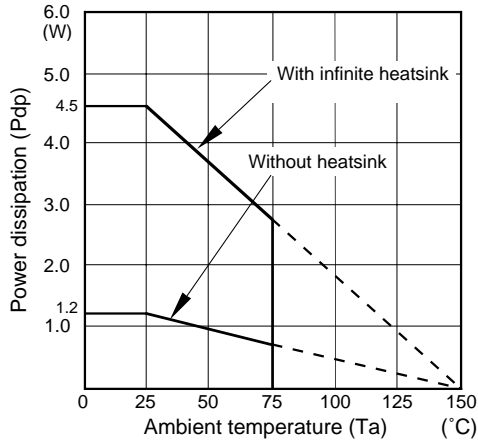

Figure 8.

**THERMAL DERATING**



**BASICALLY CHARACTERISTICS**

This data is an example for typical sample.  
Output Saturation Voltage and Load current characteristics

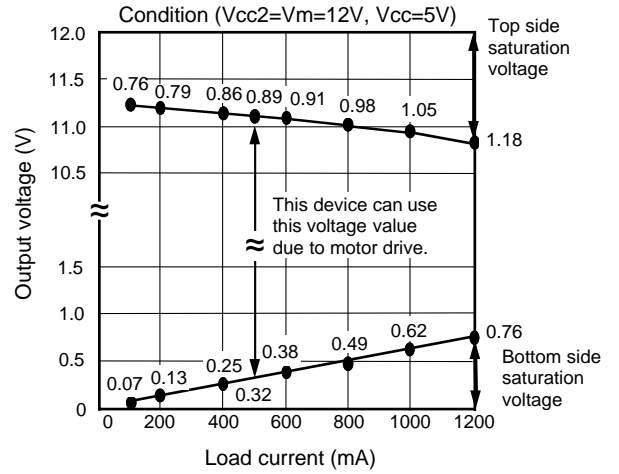

Output saturation voltage and Load current Characteristics.  
(At bootstrap)

If you use a bootstrap as below, it is possible to make low the output saturation voltage.

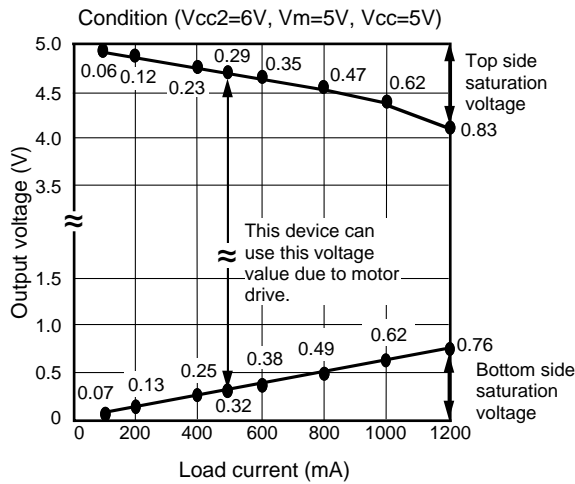

HB terminal voltage and Hall current characteristics.

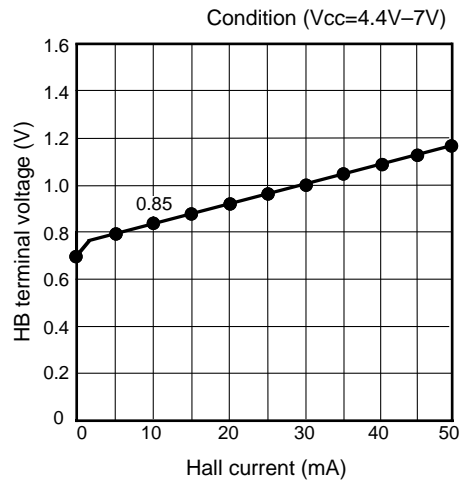



**APPLICATION CIRCUIT**

