

1.1 Scope.

This specification covers the detail requirements for Class B microcircuits in accordance with 1.2.1 of MIL-STD-883, provisions for the use of MIL-STD-883 in conjunction with complaint non-JAN devices. The device is a 40 MHz Monolithic 256 × 24 Color Palette RAM-DAC.

1.2 Part Number.

The complete part number per Table 1 of this specification is as follows:

Device	Part Number
-1	ADV453TQ/883B
-2	ADV453TE/883B

1.2.3 Case Outline.

See Appendix 1 of General Specification ADI-M-1000: package outline:

(X)	Package	Description	Lead Finish
Q	Q-40	40-Lead Dual-In-Line Package	Hot Solder DIP
E	E-44A	44-Lead LCC	Hot Solder DIP

1.3 Absolute Maximum Ratings.

Supply Voltage (V_{AA})	+7.0 V
Digital Input Voltage (V_{IN}) to AGND	-0.5 V to V_{AA} +0.5 V
Analog Output Short Circuit Duration to Any Power Supply or Common	Indefinite
Power Dissipation	1575 mW
Storage Temperature	-65°C to +150°C
Lead Temperature (Soldering 10 sec)	+300°C
Junction Temperature	+175°C

1.5 Thermal Characteristics.

Thermal Resistance θ_{JC} = See MIL-M-38510 Appendix C
 θ_{JA} = 120°C/W for Q
 θ_{JA} = 50°C/W for E

ADV453—SPECIFICATIONS

Table 1.

Test	Symbol	Limit		Group A Subgroups	Conditions ¹ ($-55^{\circ}\text{C} \leq T_A \leq +125^{\circ}\text{C}$ unless otherwise noted)	Units
		Min	Max			
Resolution (Each DAC)		8.0	8.0	4		Bits
Relative Accuracy (Each DAC)	I _L		±2	1, 2, 3	Conversion Rate is 1 MHz	LSB
Integral Nonlinearity			±1	1, 2, 3		LSB
Differential Nonlinearity		D _L				
Gray Scale Error			±5	1, 2, 3	White Level Relative to Blank	% Gray Scale
Digital Input High Voltage	V _{IH}	2.4		7, 8		V
Digital Input Low Voltage	V _{IL}		0.8	7, 8		V
Digital Input Current	I _{IN}		10	1, 2, 3	V _{IN} = 0 V or V _{AA}	μA
Digital Input Capacitance ²	C _{IN}		10	4		pF
Digital Output High Voltage	V _{OH}	2.4		1, 2, 3	I _{SOURCE} = 400 μA	V
Digital Output Low Voltage	V _{OL}		0.4	1, 2, 3	I _{SINK} = 3.2 mA	V
Floating State Output Current	I _{OZ}		10	1, 2, 3	V _{IN} = 0 V or V _{AA}	μA
Floating State Output Capacitance ²	CD _{OUT}		20	4		pF
Gray Scale Current Range		15	22	1, 2, 3		mA
Output Current						
White Level Relative to Blank		17.69	20.40	1, 2, 3		mA
White Level Relative to Black		16.74	18.50			
Black Level Relative to Blank		0.95	1.90			
Blank Level on IOR, IOB		0	50	1, 2, 3		μA
Blank Level on IOG		6.29	8.96			mA
Sync Level on IOG		0	50			μA
DAC to DAC Matching			6	1, 2, 3	White Level Relative to Blank	%
Output Compliance ³	V _{OC}	-1.0	1.4	1, 2, 3		V
Output Capacitance ²	CA _{OUT}		40	4	I _{OUT} = 0 mA	pF
Voltage Reference Range ³		1.14	1.26	1, 2, 3		V
Power Supply Current	I _{AA}		300	1, 2, 3		mA
Power Supply Rejection Ratio (White Level Relative to Black)	PSRR		30	1, 2, 3	V _{AA} = 5.0 V Delta V _{AA} = +5% or -5% (0.5 V 1 kHz Sinewave Applied to V _{AA})	dB
$\overline{\text{CS}}$ C0, C1 Setup Time	t ₁	35		9, 10, 11		ns
$\overline{\text{CS}}$ C0, C1 Hold Time	t ₂	35		9, 10, 11		ns
$\overline{\text{RD}}$, $\overline{\text{WR}}$ High Time	t ₃	25		9, 10, 11		ns
$\overline{\text{RD}}$ Assert to Data Bus Driven	t ₄	2		9, 10, 11		ns
$\overline{\text{RD}}$ Assert to Data Valid	t ₅		100	9, 10, 11		ns
$\overline{\text{RD}}$ Negated to Data Bus Three Stated	t ₆		20	9, 10, 11		ns
$\overline{\text{RD}}$, $\overline{\text{WR}}$ Low Time	t ₇	50		9, 10, 11		ns

Test	Symbol	Limit		Group A Subgroups	Conditions ¹ ($-55^{\circ}\text{C} \leq T_A \leq +125^{\circ}\text{C}$ unless otherwise noted)	Units
		Min	Max			
Write Data Setup Time	t_8	35		9, 10, 11		ns
Write Data Hold Time	t_9	10		9, 10, 11		ns
Pixel and Control Setup Time	t_{10}	7		9, 10, 11		ns
Pixel and Control Hold Time	t_{11}	3		9, 10, 11		ns
Clock Cycle Time ³	t_{12}	25		9, 10, 11		ns
Clock Pulse Width High Time	t_{13}	7		9, 10, 11		ns
Clock Pulse Width Low Time	t_{14}	7		9, 10, 11		ns
Analog Output Delay	t_{15}		30	9, 10, 11	CLK = 4 MHz	ns
Analog Output Rise/Fall Time	t_{16}		8	9, 10, 11	CLK = 4 MHz	ns
Pipeline Delay ³	t_{PD}		$2 \times t_{12}$	9, 10, 11		ns
Analog Output Skew	t_{SK}		2	9, 10, 11	CLK = 4 MHz	ns

NOTES

¹ $V_{AA} = +4.75\text{ V to }+5.25\text{ V}$, $V_{REF} = 1.235\text{ V}$, $R_{SET} = 280\ \Omega$, I_{SYNC} connected to IOG, unless otherwise specified.

²Tested on initial release and after any redesign which may affect this parameter.

³These tests are done on a pass/fail basis only. Minimum and/or maximum conditions (as appropriate) are used as input conditions.

⁴Digital input values are 0 to 3 V, with input rise/fall time, < 3 ns measured between the 10% and 90% points. Timing reference points are at 50% for inputs and outputs. See Figure 1.

ADV453

3.2.1 Functional Block Diagram and Terminal Assignments.

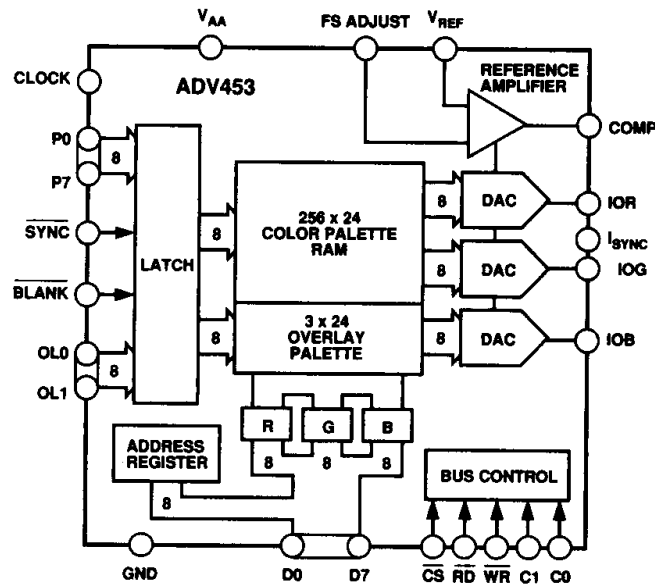

Q Package (DIP)

E Package (LCC)

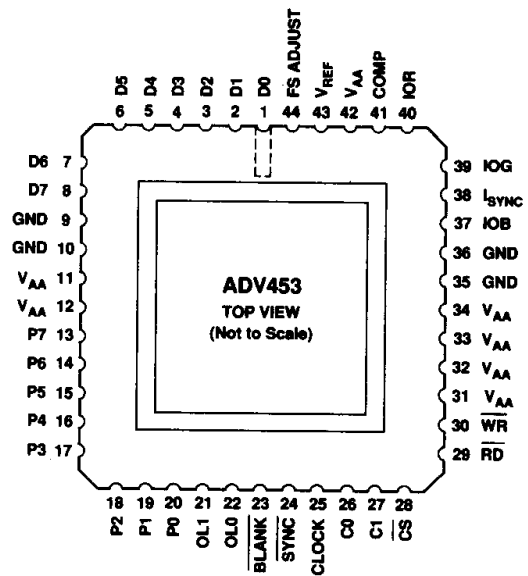
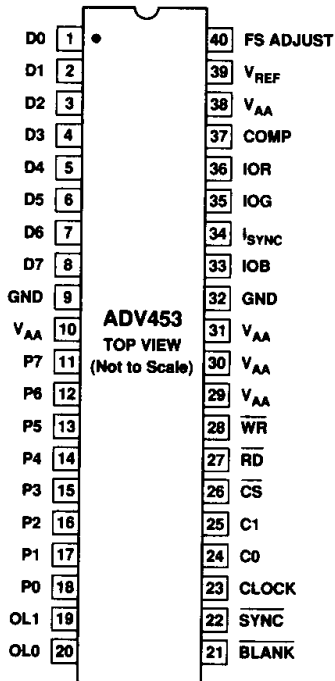

Table 2. Electrical Test Requirements

MIL-STD-883 Test Requirements	Subgroups (Per Method 5005 Table 1)
Interim Electrical Parameters (Method 5004)	1, 7, 9
Final Electrical Test Parameters (Method 5004)	1*, 2, 3, 7, 8, 9, 10, 11
Group A Test Requirements (Method 5005)	1, 2, 3, 7, 8A, 8B, 9, 10, 11
Group C and D Endpoint Electrical Parameters (Method 5005)	1, 7, 9

*PDA applies to subgroup 1.

4.3.2 Group C and D Inspections

- a. Endpoint electrical parameters shall be as specified in Table 2 herein.
- b. Steady-state life test conditions, method 1005 of MIL-STD-883.
 Test Condition A, B, C or D using the circuit in E Package Drawing.
 $T_A = 125^\circ\text{C}$, Min
 Test Duration: 1,000 hours, except as permitted by method 1005 of MIL-STD-883.

5. Packing

5.1 Packaging Requirements

The requirements for packaging shall be in accordance with MIL-M-38510.

Table 3.

Description	IOG (mA)	IOR, IOB (mA)	$\overline{\text{SYNC}}$	$\overline{\text{BLANK}}$	DAC Input Data
White Level	26.67	19.05	1	1	FFH
Video	Video + 9.05	Video + 1.44	1	1	Data
Video to Blank	Video + 1.44	Video + 1.44	0	1	Data
Black Level	9.05	1.44	1	1	00H
Black to Blank	1.44	1.44	0	1	00H
Blank Level	7.62	0	1	0	XXH
SYNC Level	0	0	0	0	XXH

Notes

1. Typical with full scale IOG = 26.67 mA.
2. $V_{\text{REF}} = +1.235 \text{ V}$, $R_{\text{SET}} = 280 \Omega$. I_{SYNC} connected to IOG.

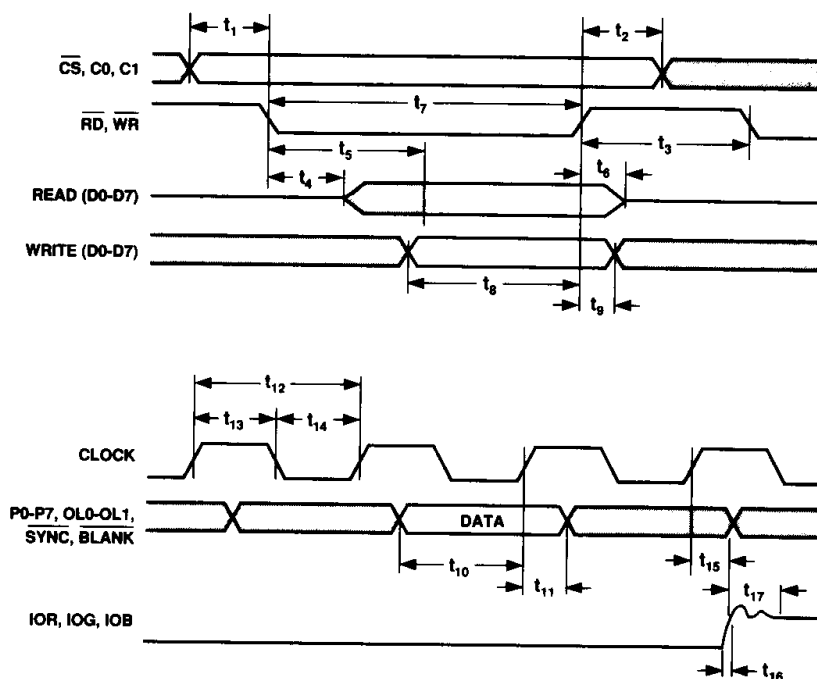

NOTES

1. OUTPUT DELAY (t_{15}) MEASURED FROM THE 50% POINT OF THE RISING EDGE OF CLOCK TO THE 50% POINT OF FULL SCALE TRANSITION.
2. SETTLING TIME (t_{17}) MEASURED FROM THE 50% POINT OF FULL SCALE TRANSITION TO THE OUTPUT REMAINING WITHIN $\pm 1\text{LSB}$.
3. OUTPUT RISE/FALL TIME (t_{16}) MEASURED BETWEEN THE 10% AND 90% POINTS OF FULL SCALE TRANSITION.

Figure 1. Timing Diagrams