



■ General Description

The AME41-4096 is a micropower 2-terminal band-gap voltage regulator diode. It operates over a 40µA to 20mA current range. Each circuit is trimmed at wafer sort to provide a ±0.20% and ±0.50% initial tolerance. The design of the AME41-4096 allows for a large range of load capacitances and operating currents. The low start-up current makes these part ideal for battery applications.

Analog Microelectronics offers this part in a TO-92 and SO-8 packages as well as the space saving SOT-23.

■ Key Features

- Small packages: SOT-23, TO-92, SO-8
- Tolerates capacitive loads
- Fixed reverse breakdown voltage of 4.096V
- Tight voltage tolerance ----- ±0.20%, ±0.50%
- Wide operating current ----- 40µA to 20mA
- Wide temperature range ----- -40°C to 85°C
- Low temperature coefficient --- 100ppm/°C (max)
- Excellent transient response

■ Applications

- Portable electronics
- Power supplies
- Computer peripherals
- Data acquisition systems
- Battery chargers
- Consumer electronics

■ Functional Block Diagram

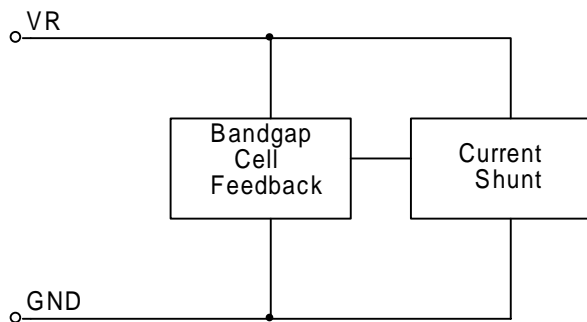

■ Typical Application

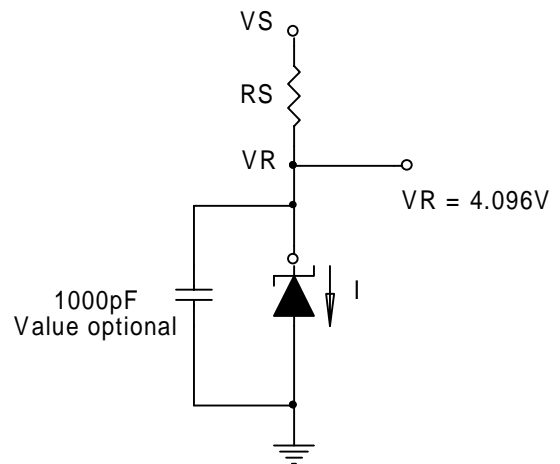

$$R_S = \frac{V_S - V_R}{I}$$



■ Package Outline

SOT-23 Top View

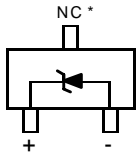

TO-92-3 Bottom View

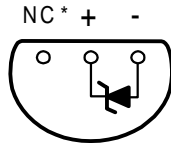

TO-92-2 Bottom View

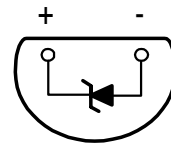

SO-8 Top View

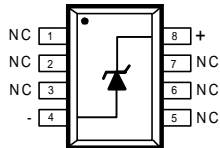

* The NC pin must float or be connected to - (negative)

■ Ordering Information

Part Number	Accuracy	Marking	Package	Operating Temp. Range
AME41FEET	0.2%	ADAww	SOT-23	-40°C to +85°C
AME41FEHA	0.2%	AME 41FEHA yyww	SO-8	-40°C to +85°C
AME41CEET	0.5%	ACCww	SOT-23	-40°C to +85°C
AME41CEAS	0.5%	AME 41 CEAS yyww	TO-92-2	-40°C to +85°C
AME41CEAT	0.5%	AME 41 CEAT yyww	TO-92-3	-40°C to +85°C
AME41CEHA	0.5%	AME 41CEHA yyww	SO-8	-40°C to +85°C

Please consult AME sales office or authorized Rep./Distributor for other voltage accuracy and package type availability.



■ Absolute Maximum Ratings

Parameter	Maximum	Unit
Supply Current	50	mA

■ Recommended Operating Conditions

Parameter	Rating	Unit
Supply Current	100 μ A ~ 20mA	
Ambient Temperature Range	-40 to +85	$^{\circ}$ C
Junction Temperature	-40 to +125	$^{\circ}$ C

■ Thermal Information

Parameter		Maximum	Unit
Thermal Resistance	SOT-23	325	$^{\circ}$ C / W
	TO-92	180	
	SO-8	124	
Maximum Junction Temperature		150	$^{\circ}$ C
Maximum Lead Temperature (10 Sec)		300	$^{\circ}$ C

Caution: Stress above the listed absolute rating may cause permanent damage to the device



■ Electrical Specifications

Unless otherwise specified, $T_A = 25^\circ\text{C}$, $I = 100\mu\text{A}$

PARAMETER	SYMBOL	TEST CONDITIONS	MIN	TYP	MAX	UNITS
Reference Voltage, $\pm 0.2\%$	V_{REF}	$T_A = 25^\circ\text{C}$, $I_{\text{REF}} = 100\mu\text{A}$	4.088	4.096	4.104	V
Reference Voltage, $\pm 0.5\%$			4.075	4.096	4.117	V
Minimum Current	I_{MIN}				40	μA
Reference Voltage Change With Current	$dV_{\text{REF}/I}$	$I_{\text{MIN}} \leq I \leq 1\text{mA}$		1.5	3	mV
		$1\text{mA} \leq I \leq 20\text{mA}$		10	20	
Reference Voltage Temp. Coeff.	V_{REFTC}	$0^\circ\text{C} < T_A < 70^\circ\text{C}$			100	ppm/ $^\circ\text{C}$



Normalized Percentage Change vs. Temperature

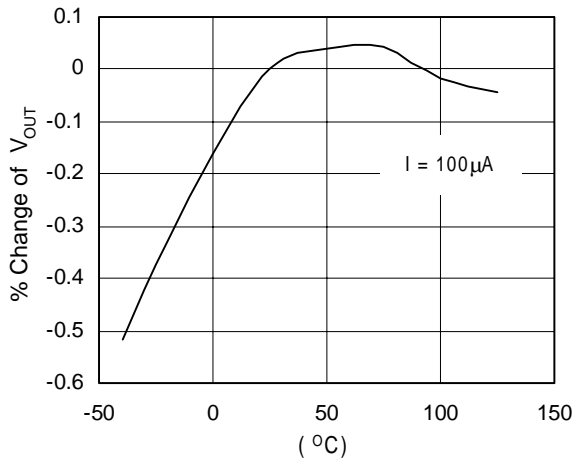

Output Voltage Change vs. Current

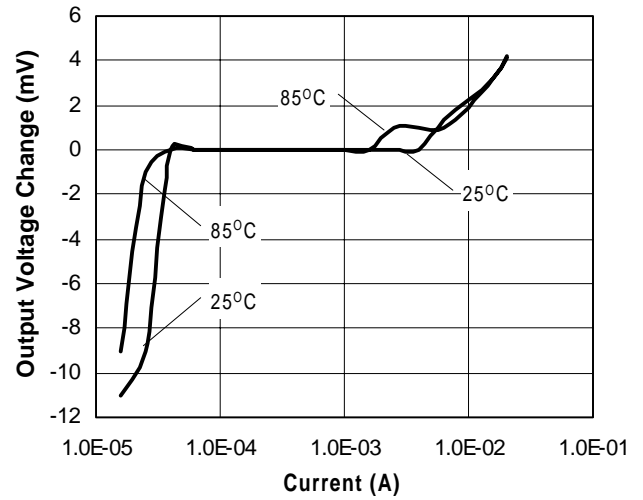

Reverse Characteristic

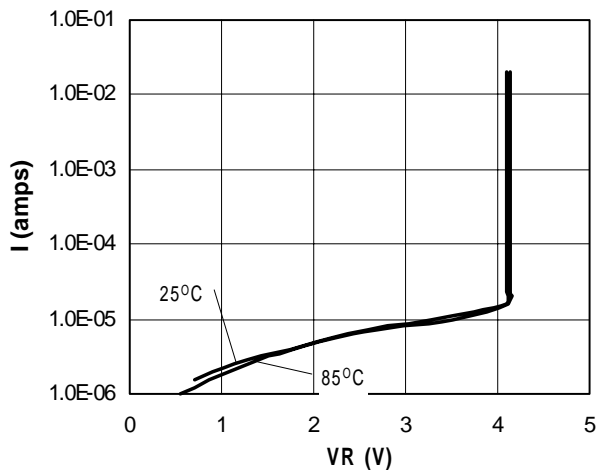

Forward Characteristic

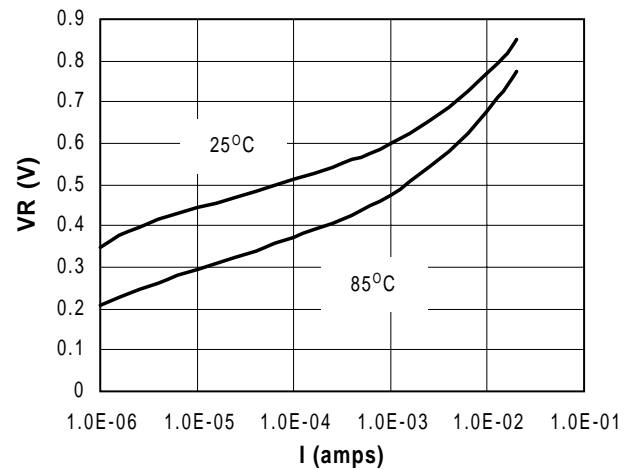

Transient Response

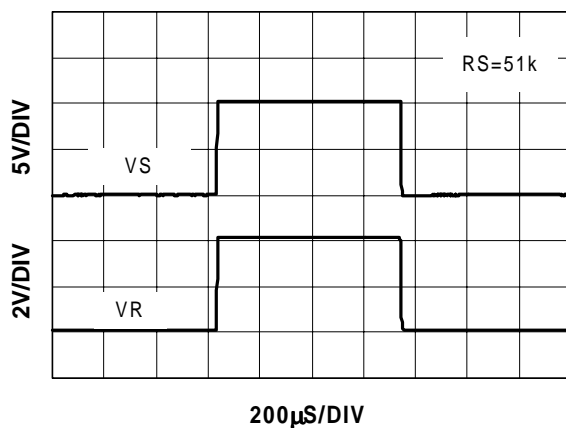



■ Package Dimension

SOT-23

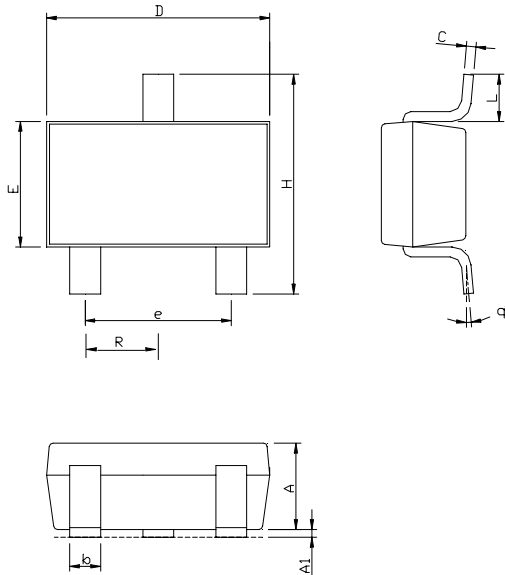

SYMBOLS	MILLIMETERS		INCHES	
	MIN	MAX	MIN	MAX
A	1.00	1.40	0.0394	0.0551
A ₁	0.00	0.15	0.0000	0.0059
b	0.35	0.50	0.0138	0.0197
C	0.09	0.25	0.0035	0.0098
D	2.70	3.10	0.1063	0.1220
E	1.40	1.80	0.0551	0.0709
e	1.90 BSC		0.0748 BSC	
H	2.60	3.00	0.1024	0.1181
L	0.35	0.55	0.0138	0.0197
θ ₁	0°	9°	0°	9°
R	0.95(TYP)		0.0374(TYP)	

SO-8

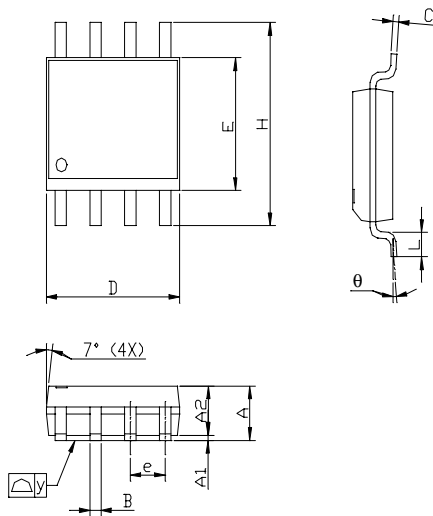

SYMBOLS	MILLIMETERS		INCHES	
	MIN	MAX	MIN	MAX
A	1.35	1.75	0.053	0.069
A ₁	0.10	0.25	0.004	0.010
A ₂	1.45 REF		0.057 REF	
B	0.33	0.51	0.013	0.020
C	0.19	0.25	0.007	0.010
D	4.80	5.00	0.189	0.1970
E	3.80	4.00	0.150	0.157
e	1.27 BSC		0.050 BSC	
H	5.80	6.20	0.228	0.244
L	0.40	1.27	0.016	0.050
y		0.10		0.004
θ	0°	8°	0°	8°



■ Package Dimension

TO-92-3

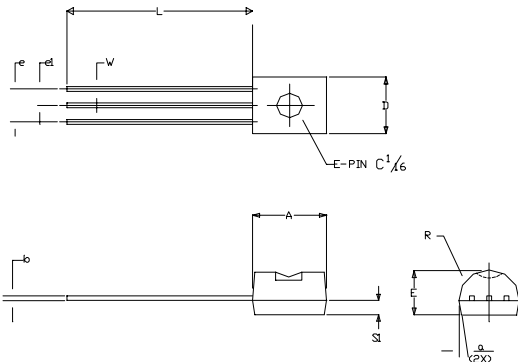

SYMBOLS	MILLIMETERS		INCHES	
	MIN	MAX	MIN	MAX
A	4.32	4.95	0.170	0.195
b	0.36	0.51	0.014	0.020
E	3.30	3.94	0.130	0.155
e	2.41	2.67	0.095	0.105
e1	1.14	1.40	0.045	0.055
L	12.70	15.49	0.500	0.610
R	2.16	2.41	0.085	0.095
S1	1.14	1.52	0.045	0.060
W	0.41	0.56	0.016	0.022
D	4.45	4.95	0.175	0.195
a	4°	6°	4°	6°

NOTE:

1. PACKAGE OUTLINE EXCLUSIVE OF ANY MOLD FLASHES DIMENSION
2. PACKAGE OUTLINE EXCLUSIVE OF BURR DIMENSION

TO-92-2

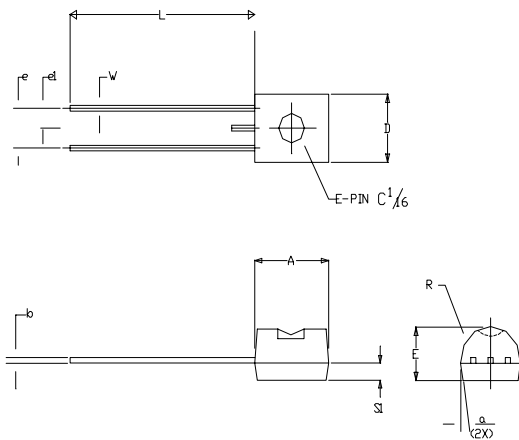

SYMBOLS	MILLIMETERS		INCHES	
	MIN	MAX	MIN	MAX
A	4.32	4.95	0.170	0.195
b	0.36	0.51	0.014	0.020
E	3.30	3.94	0.130	0.155
e	2.41	2.67	0.095	0.105
e1	1.14	1.40	0.045	0.055
L	12.70	15.49	0.500	0.610
R	2.16	2.41	0.085	0.095
S1	1.14	1.52	0.045	0.060
W	0.41	0.56	0.016	0.022
D	4.45	4.95	0.175	0.195
a	4°	6°	4°	6°

NOTE:

1. PACKAGE OUTLINE EXCLUSIVE OF ANY MOLD FLASHES DIMENSION
2. PACKAGE OUTLINE EXCLUSIVE OF BURR DIMENSION



www.analogmicro.com
E-Mail: info@analogmicro.com

Life Support Policy:

These products of Analog Microelectronics, Inc. are not authorized for use as critical components in life-support devices or systems, without the express written approval of the president of Analog Microelectronics, Inc.

Analog Microelectronics, Inc. reserves the right to make changes in the circuitry and specifications of its devices and advises its customers to obtain the latest version of relevant information.

© Analog Microelectronics, Inc. , October 2001

Document: 2003-DS41-4096-D

Corporate Headquarters
Analog Microelectronics, Inc.

3100 De La Cruz Blvd. Suite 201
Santa Clara, CA. 95054-2046
Tel : (408) 988-2388
Fax: (408) 988-2489

Asia Pacific Headquarters
AME, Inc.

2F, 187 Kang-Chien Road, Nei-Hu District
Taipei 114, Taiwan, R.O.C.
Tel : 886 2 2627-8687
Fax: 886 2 2659-2989