

■ General Description

The AME8550 series are highly precise, low power consumption voltage detectors, manufactured using CMOS and fuse trimming technologies. Detect voltage is extremely accurate with minimal temperature drift.

Both CMOS and N channel open drain output configurations are available.

■ Features

- Highly accurate: $\pm 2\%$
- Low power consumption: TYP $0.8\mu\text{A}$ ($V_{DD}=1.5\text{V}$)
- Detect voltage range: 1.6V to 6.0V in 0.1V increments
- Operating voltage range: 1.2V to 6.5V
- Detect voltage temperature characteristics: TYP $\pm 100\text{ppm}/^\circ\text{C}$
- Output configuration: N-channel open drain or CMOS
- Ultra small package :
 - SOT-23 (150mW)
 - SOT-25 (150mW)
 - SOT-89 (500mW)
 - SC-70 (100mW)
- Add an external capacitor to perform an μP reset.

■ Applications

- Microprocessor reset circuitry
- Memory battery back-up circuits
- Power-on reset circuits
- Power failure detection
- System battery life and charge voltage monitors

■ Functional Block Diagram

(1) CMOS Output without delay

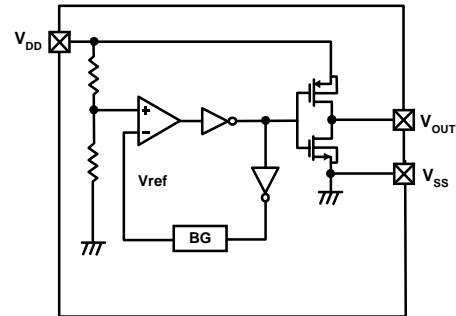

(2) Nch Open Drain Output without delay

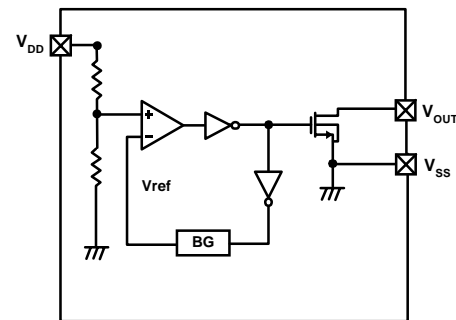

(3) CMOS Output with delay

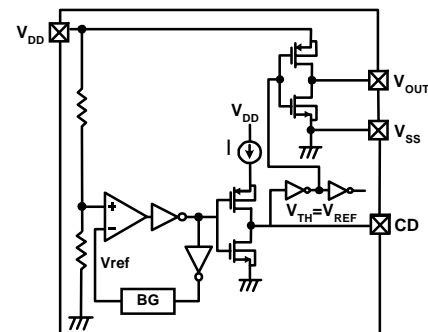

(4) Nch Open Drain Output with delay

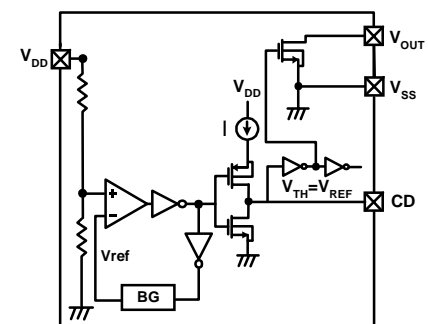

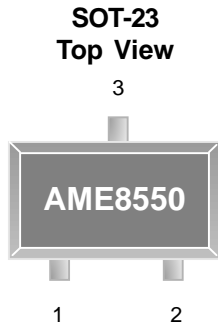
■ Pin Configuration
● Without Delay Time

AME8550AEETXXXX

1. V_{OUT}
2. V_{SS}
3. V_{DD}

AME8550AEFTXXXX

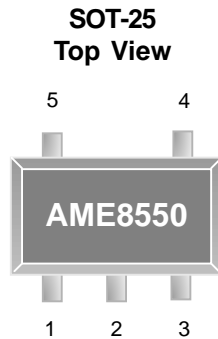
1. V_{OUT}
2. V_{DD}
3. V_{SS}

AME8550CEEVXXXX

1. V_{OUT}
2. V_{DD}
3. V_{SS}
4. NC
5. NC

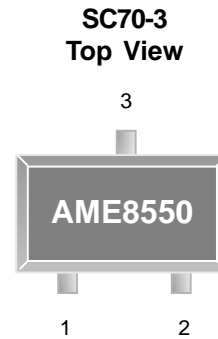
AME8550AEITXXXX

1. V_{SS}
2. V_{OUT}
3. V_{DD}

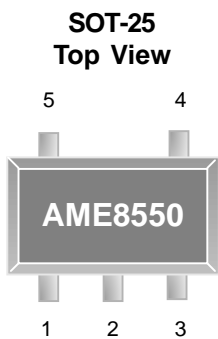
● With Delay Time

AME8550AEEVXXXX

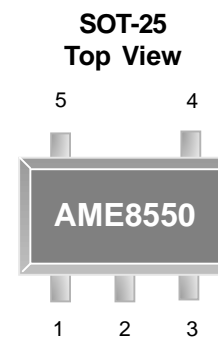
1. V_{OUT}
2. V_{DD}
3. V_{SS}
4. CD
5. NC

AME8550BEEVXXXX

1. V_{OUT}
2. V_{DD}
3. V_{SS}
4. NC
5. CD

■ Pin Description

Pin Name	Pin Description
V_{DD}	Supply Voltage Input
V_{SS}	Ground
V_{OUT}	Output
NC	No Connection
CD	Connect an external capacitor when delay function is needed



■ Ordering Information

- Without Delay Time

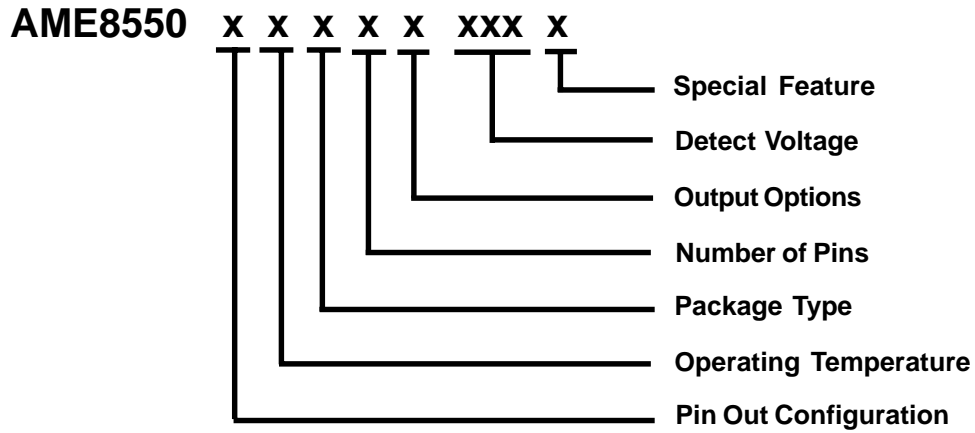

Pin Configuration	Operating Temperature Range	Package Type	Number of Pins	Output Options	Detect Voltage	Special Feature
A 1. VOUT (SOT-23) 2. VSS 3. VDD	E: -40°C to 85°C	E: SOT-2X F: SOT-89	T: 3 V: 5	A: CMOS output without delay B: Open-Drain output without delay	190: V=1.9V 200: V=2.0V 220: V=2.2V 230: V=2.3V 240: V=2.4V 250: V=2.5V 263: V=2.63V 270: V=2.7V 280: V=2.8V 360: V=3.6V 370: V=3.7V 420: V=4.2V 440: V=4.4V 460: V=4.6V	L: Low profile Y: Lead free & Low profile Z: Lead free
A 1. VOUT (SOT-89) 2. VDD 3. VSS						
A 1. VSS (SC70-3) 2. VOUT 3. VDD						
C 1. VOUT (SOT-25) 2. VDD 3. VSS 4. NC 5. NC						



■ Ordering Information

- With Delay Time

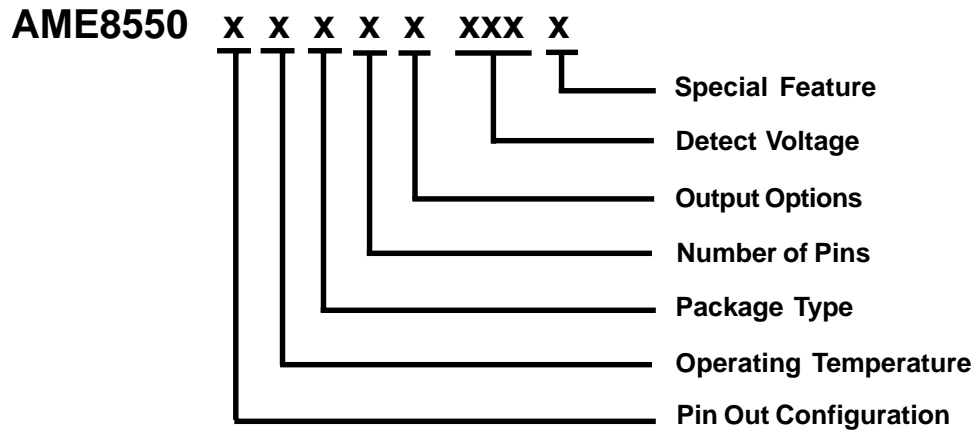

Pin Configuration	Operating Temperature Range	Package Type	Number of Pins	Output Options	Detect Voltage	Special Feature
A 1. VOUT (SOT-25) 2. VDD 3. VSS 4. CD 5. NC B 1. VOUT 2. VDD 3. VSS 4. NC 5. CD	E: -40°C to 85°C	E: SOT-2X F: SOT-89	T: 3 V: 5	C: CMOS output with delay D: Open-Drain output with delay	190: V=1.9V 200: V=2.0V 220: V=2.2V 230: V=2.3V 240: V=2.4V 250: V=2.5V 263: V=2.63V 270: V=2.7V 280: V=2.8V 360: V=3.6V 370: V=3.7V 420: V=4.2V 440: V=4.4V 460: V=4.6V	L: Low profile Y: Lead free & Low profile Z: Lead free

■ Ordering Information (contd.)

Part Number	Marking	Output Voltage	Package	Operating Temp. Range
AME8550AEEVC190	AXOww	1.9V	SOT-25	-40°C to +85°C
AME8550AEEVC190L	AXOww	1.9V	SOT-25	-40°C to +85°C
AME8550AEEVC190Z	AXOww	1.9V	SOT-25	-40°C to +85°C
AME8550AEEVC190Y	AXOww	1.9V	SOT-25	-40°C to +85°C
AME8550BEEVC190	AXPww	1.9V	SOT-25	-40°C to +85°C
AME8550BEEVC190L	AXPww	1.9V	SOT-25	-40°C to +85°C
AME8550BEEVC190Z	AXPww	1.9V	SOT-25	-40°C to +85°C
AME8550BEEVC190Y	AXPww	1.9V	SOT-25	-40°C to +85°C
AME8550AEETB210	AXQww	2.1V	SOT-23	-40°C to +85°C
AME8550AEETB210L	AXQww	2.1V	SOT-23	-40°C to +85°C
AME8550AEETB210Z	AXQww	2.1V	SOT-23	-40°C to +85°C
AME8550AEETB210Y	AXQww	2.1V	SOT-23	-40°C to +85°C
AME8550AEFTB210	A8550A B210ww	2.1V	SOT-89	-40°C to +85°C
AME8550AEFTB210Z	A8550A B210ww	2.1V	SOT-89	-40°C to +85°C
AME8550CEEVB210	AXRww	2.1V	SOT-25	-40°C to +85°C
AME8550CEEVB210L	AXRww	2.1V	SOT-25	-40°C to +85°C
AME8550CEEVB210Z	AXRww	2.1V	SOT-25	-40°C to +85°C
AME8550CEEVB210Y	AXRww	2.1V	SOT-25	-40°C to +85°C
AME8550AEETA220	AWHww	2.2V	SOT-23	-40°C to +85°C
AME8550AEETA220L	AWHww	2.2V	SOT-23	-40°C to +85°C
AME8550AEETA220Z	AWHww	2.2V	SOT-23	-40°C to +85°C
AME8550AEETA220Y	AWHww	2.2V	SOT-23	-40°C to +85°C
AME8550AEFTA220	A8550A A220ww	2.2V	SOT-89	-40°C to +85°C
AME8550AEFTA220Z	A8550A A220ww	2.2V	SOT-89	-40°C to +85°C
AME8550AEITA220	AXKw	2.2V	SC70-3	-40°C to +85°C
AME8550AEITA220Z	AXKw	2.2V	SC70-3	-40°C to +85°C



■ Ordering Information (contd.)

Part Number	Marking	Output Voltage	Package	Operating Temp. Range
AME8550AEETB240	AXVww	2.4V	SOT-23	-40°C to +85°C
AME8550AEETB240L	AXVww	2.4V	SOT-23	-40°C to +85°C
AME8550AEETB240Z	AXVww	2.4V	SOT-23	-40°C to +85°C
AME8550AEETB240Y	AXVww	2.4V	SOT-23	-40°C to +85°C
AME8550AEFTB240	A8550A B240ww	2.4V	SOT-89	-40°C to +85°C
AME8550AEFTB240Z	A8550A B240ww	2.4V	SOT-89	-40°C to +85°C
AME8550CEEVB240	AXWww	2.4V	SOT-25	-40°C to +85°C
AME8550CEEVB240L	AXWww	2.4V	SOT-25	-40°C to +85°C
AME8550CEEVB240Z	AXWww	2.4V	SOT-25	-40°C to +85°C
AME8550CEEVB240Y	AXWww	2.4V	SOT-25	-40°C to +85°C
AME8550AEEVD240	AXXww	2.4V	SOT-25	-40°C to +85°C
AME8550AEEVD240L	AXXww	2.4V	SOT-25	-40°C to +85°C
AME8550AEEVD240Z	AXXww	2.4V	SOT-25	-40°C to +85°C
AME8550AEEVD240Y	AXXww	2.4V	SOT-25	-40°C to +85°C
AME8550BEEVD240	AXYww	2.4V	SOT-25	-40°C to +85°C
AME8550BEEVD240L	AXYww	2.4V	SOT-25	-40°C to +85°C
AME8550BEEVD240Z	AXYww	2.4V	SOT-25	-40°C to +85°C
AME8550BEEVD240Y	AXYww	2.4V	SOT-25	-40°C to +85°C
AME8550AEETB250	AXZww	2.5V	SOT-23	-40°C to +85°C
AME8550AEETB250L	AXZww	2.5V	SOT-23	-40°C to +85°C
AME8550AEETB250Z	AXZww	2.5V	SOT-23	-40°C to +85°C
AME8550AEETB250Y	AXZww	2.5V	SOT-23	-40°C to +85°C
AME8550AEFTB250	A8550A B250ww	2.5V	SOT-89	-40°C to +85°C
AME8550AEFTB250Z	A8550A B250ww	2.5V	SOT-89	-40°C to +85°C

Note: ww represents the date code / w represents date code (A thru Z) : 2 work weeks per character.

* A line on top of the first letter represents lead free plating such as A[~]ME8550

Please consult AME sales office or authorized Rep./Distributor for the availability of output voltage and package type .

■ Ordering Information (contd.)

Part Number	Marking	Output Voltage	Package	Operating Temp. Range
AME8550CEEVB250	AYAww	2.5V	SOT-25	-40°C to +85°C
AME8550CEEVB250L	AYAww	2.5V	SOT-25	-40°C to +85°C
AME8550CEEVB250Z	AYAww	2.5V	SOT-25	-40°C to +85°C
AME8550CEEVB250Y	AYAww	2.5V	SOT-25	-40°C to +85°C
AME8550AEEVD260	AYVww	2.6V	SOT-25	-40°C to +85°C
AME8550AEEVD260L	AYVww	2.6V	SOT-25	-40°C to +85°C
AME8550AEEVD260Z	AYVww	2.6V	SOT-25	-40°C to +85°C
AME8550AEEVD260Y	AYVww	2.6V	SOT-25	-40°C to +85°C
AME8550BEEVD260	AYWww	2.6V	SOT-25	-40°C to +85°C
AME8550BEEVD260L	AYWww	2.6V	SOT-25	-40°C to +85°C
AME8550BEEVD260Z	AYWww	2.6V	SOT-25	-40°C to +85°C
AME8550BEEVD260Y	AYWww	2.6V	SOT-25	-40°C to +85°C
AME8550AEETA270	AWlww	2.7V	SOT-23	-40°C to +85°C
AME8550AEETA270L	AWlww	2.7V	SOT-23	-40°C to +85°C
AME8550AEETA270Z	AWlww	2.7V	SOT-23	-40°C to +85°C
AME8550AEETA270Y	AWlww	2.7V	SOT-23	-40°C to +85°C
AME8550AEFTA270	A8550A A270ww	2.7V	SOT-89	-40°C to +85°C
AME8550AEFTA270Z	A8550A A270ww	2.7V	SOT-89	-40°C to +85°C
AME8550AEITA270	AXNw	2.7V	SC70-3	-40°C to +85°C
AME8550AEITA270Z	AXNw	2.7V	SC70-3	-40°C to +85°C
AME8550AEETB270	AWVww	2.7V	SOT-23	-40°C to +85°C
AME8550AEETB270L	AWVww	2.7V	SOT-23	-40°C to +85°C
AME8550AEETB270Z	AWVww	2.7V	SOT-23	-40°C to +85°C
AME8550AEETB270Y	AWVww	2.7V	SOT-23	-40°C to +85°C
AME8550AEFTB270	A8550A B270ww	2.7V	SOT-89	-40°C to +85°C
AME8550AEFTB270Z	A8550A B270ww	2.7V	SOT-89	-40°C to +85°C



■ Ordering Information (contd.)

Part Number	Marking	Output Voltage	Package	Operating Temp. Range
AME8550CEEVB270	AYSww	2.7V	SOT-25	-40°C to +85°C
AME8550CEEVB270L	AYSww	2.7V	SOT-25	-40°C to +85°C
AME8550CEEVB270Z	AYSww	2.7V	SOT-25	-40°C to +85°C
AME8550CEEVB270Y	AYSww	2.7V	SOT-25	-40°C to +85°C
AME8550AEEVD270	AYXww	2.7V	SOT-25	-40°C to +85°C
AME8550AEEVD270L	AYXww	2.7V	SOT-25	-40°C to +85°C
AME8550AEEVD270Z	AYXww	2.7V	SOT-25	-40°C to +85°C
AME8550AEEVD270Y	AYXww	2.7V	SOT-25	-40°C to +85°C
AME8550BEEVD270	AYYww	2.7V	SOT-25	-40°C to +85°C
AME8550BEEVD270L	AYYww	2.7V	SOT-25	-40°C to +85°C
AME8550BEEVD270Z	AYYww	2.7V	SOT-25	-40°C to +85°C
AME8550BEEVD270Y	AYYww	2.7V	SOT-25	-40°C to +85°C
AME8550AEETB280	AYBww	2.8V	SOT-23	-40°C to +85°C
AME8550AEETB280L	AYBww	2.8V	SOT-23	-40°C to +85°C
AME8550AEETB280Z	AYBww	2.8V	SOT-23	-40°C to +85°C
AME8550AEETB280Y	AYBww	2.8V	SOT-23	-40°C to +85°C
AME8550AEFTB280	A8550A B280ww	2.8V	SOT-89	-40°C to +85°C
AME8550AEFTB280Z	A8550A B280ww	2.8V	SOT-89	-40°C to +85°C
AME8550CEEVB280	AYCww	2.8V	SOT-25	-40°C to +85°C
AME8550CEEVB280L	AYCww	2.8V	SOT-25	-40°C to +85°C
AME8550CEEVB280Z	AYCww	2.8V	SOT-25	-40°C to +85°C
AME8550CEEVB280Y	AYCww	2.8V	SOT-25	-40°C to +85°C
AME8550AEEVC290	AYDww	2.9V	SOT-25	-40°C to +85°C
AME8550AEEVC290L	AYDww	2.9V	SOT-25	-40°C to +85°C
AME8550AEEVC290Z	AYDww	2.9V	SOT-25	-40°C to +85°C
AME8550AEEVC290Y	AYDww	2.9V	SOT-25	-40°C to +85°C

■ Ordering Information (contd.)

Part Number	Marking	Output Voltage	Package	Operating Temp. Range
AME8550BEEVC290	AYEww	2.9V	SOT-25	-40°C to +85°C
AME8550BEEVC290L	AYEww	2.9V	SOT-25	-40°C to +85°C
AME8550BEEVC290Z	AYEww	2.9V	SOT-25	-40°C to +85°C
AME8550BEEVC290Y	AYEww	2.9V	SOT-25	-40°C to +85°C
AME8550AEETA300	AYFww	3.0V	SOT-23	-40°C to +85°C
AME8550AEETA300L	AYFww	3.0V	SOT-23	-40°C to +85°C
AME8550AEETA300Z	AYFww	3.0V	SOT-23	-40°C to +85°C
AME8550AEETA300Y	AYFww	3.0V	SOT-23	-40°C to +85°C
AME8550AEFTA300	A8550A A300ww	3.0V	SOT-89	-40°C to +85°C
AME8550AEFTA300Z	A8550A A300ww	3.0V	SOT-89	-40°C to +85°C
AME8550CEEVA300	AYGww	3.0V	SOT-25	-40°C to +85°C
AME8550CEEVA300L	AYGww	3.0V	SOT-25	-40°C to +85°C
AME8550CEEVA300Z	AYGww	3.0V	SOT-25	-40°C to +85°C
AME8550CEEVA300Y	AYGww	3.0V	SOT-25	-40°C to +85°C
AME8550AEETB340	AYHww	3.4V	SOT-23	-40°C to +85°C
AME8550AEETB340L	AYHww	3.4V	SOT-23	-40°C to +85°C
AME8550AEETB340Z	AYHww	3.4V	SOT-23	-40°C to +85°C
AME8550AEETB340Y	AYHww	3.4V	SOT-23	-40°C to +85°C
AME8550AEFTB340	A8550A B340ww	3.4V	SOT-89	-40°C to +85°C
AME8550AEFTB340Z	A8550A B340ww	3.4V	SOT-89	-40°C to +85°C
AME8550CEEVB340	AYlww	3.4V	SOT-25	-40°C to +85°C
AME8550CEEVB340L	AYlww	3.4V	SOT-25	-40°C to +85°C
AME8550CEEVB340Z	AYlww	3.4V	SOT-25	-40°C to +85°C
AME8550CEEVB340Y	AYlww	3.4V	SOT-25	-40°C to +85°C



■ Ordering Information (contd.)

Part Number	Marking	Output Voltage	Package	Operating Temp. Range
AME8550AEEVD360	AYJww	3.6V	SOT-25	-40°C to +85°C
AME8550AEEVD360L	AYJww	3.6V	SOT-25	-40°C to +85°C
AME8550AEEVD360Z	AYJww	3.6V	SOT-25	-40°C to +85°C
AME8550AEEVD360Y	AYJww	3.6V	SOT-25	-40°C to +85°C
AME8550BEEVD360	AYKww	3.6V	SOT-25	-40°C to +85°C
AME8550BEEVD360L	AYKww	3.6V	SOT-25	-40°C to +85°C
AME8550BEEVD360Z	AYKww	3.6V	SOT-25	-40°C to +85°C
AME8550BEEVD360Y	AYKww	3.6V	SOT-25	-40°C to +85°C
AME8550AEETB440	AYLww	4.4V	SOT-23	-40°C to +85°C
AME8550AEETB440L	AYLww	4.4V	SOT-23	-40°C to +85°C
AME8550AEETB440Z	AYLww	4.4V	SOT-23	-40°C to +85°C
AME8550AEETB440Y	AYLww	4.4V	SOT-23	-40°C to +85°C
AME8550AEFTB440	A8550A B440ww	4.4V	SOT-89	-40°C to +85°C
AME8550AEFTB440Z	A8550A B440ww	4.4V	SOT-89	-40°C to +85°C
AME8550CEEVB440	AYMww	4.4V	SOT-25	-40°C to +85°C
AME8550CEEVB440L	AYMww	4.4V	SOT-25	-40°C to +85°C
AME8550CEEVB440Z	AYMww	4.4V	SOT-25	-40°C to +85°C
AME8550CEEVB440Y	AYMww	4.4V	SOT-25	-40°C to +85°C
AME8550AEEVC460	AYNww	4.6V	SOT-25	-40°C to +85°C
AME8550AEEVC460L	AYNww	4.6V	SOT-25	-40°C to +85°C
AME8550AEEVC460Z	AYNww	4.6V	SOT-25	-40°C to +85°C
AME8550AEEVC460Y	AYNww	4.6V	SOT-25	-40°C to +85°C
AME8550BEEVC460	AYOww	4.6V	SOT-25	-40°C to +85°C
AME8550BEEVC460L	AYOww	4.6V	SOT-25	-40°C to +85°C
AME8550BEEVC460Z	AYOww	4.6V	SOT-25	-40°C to +85°C
AME8550BEEVC460Y	AYOww	4.6V	SOT-25	-40°C to +85°C



■ Absolute Maximum Ratings

Parameter		Symbol	Maximum	Unit
Input Voltage		V_{DD}	7	V
Output Current		I_{OUT}	50	mA
Output Voltage	CMOS	V_{OUT}	$V_{SS} - 0.3$ to $V_{DD} + 0.3$	V
	Nch open drain		$V_{SS} - 0.3$ to 7	
Power Dissipation	SOT-23		150	mW
	SOT-25		150	
	SOT-89		500	
	SC-70		100	
Operating Ambient Temperature Range		T_{opr}	-40 to +85	°C
Storage Temperature Range		T_{STG}	- 40 to +125	

Caution: Stress above the listed absolute rating may cause permanent damage to the device



■ Electrical Specifications

TA = 25°C, V_{DF}(T)=1.6 to 6.0V ± 2%

Parameter	Symbol	Test Condition	Min	Typ	Max	Units	
Detect Voltage	V _{DF}		V _{DF} x0.98	V _{DF}	V _{DF} x1.02	V	
Hysteresis Range	V _{HYS} / V _{DF}		2		8	%	
Supply Current	I _{SS}	V _{DD} =V _{DF} +0.5V	1.5 < V _{DF} < 2.0		0.9	2.7	μA
			2.0 ≤ V _{DF} < 3.0		1.0	3.0	
			3.0 ≤ V _{DF} < 4.0		1.1	3.2	
			4.0 ≤ V _{DF} ≤ 5.0		1.2	3.6	
			5.0 < V _{DF} ≤ 6.0		2	4.0	
Operating Voltage	V _{DD}	V _{DF} (T)=1.6V to 6.0V	1.2		6.5	V	
Output Current	I _{OUT}	Nch V _{DS} =0.5V V _{DD} =1.0V V _{DD} =2.0V V _{DD} =3.0V V _{DD} =4.0V V _{DD} =5.0V				mA	
			1.0	2.2			
			3.0	7.7			
			5.0	10.1			
			6.0	11.5			
			7.0	13.0			
		Pch V _{DS} =2.1V V _{DD} =7V (with CMOS output)		-10.0	-2.0		
Temperature Characteristics	$\frac{\Delta V_{DF}}{\Delta \text{Topr} \cdot V_{DF}}$	-40°C ≤ Topr ≤ 85°C		-100		ppm/°C	
Propagation Time (V _{DR} → V _{OUT} inversion)	tDLY				0.2	ms	

Note:

V_{DF}(T) : Established Detect Voltage Value

Release Voltage : V_{DR} = V_{DF} + V_{HYS}

■ Functional Description (CMOS output without delay)

1. When input voltage (V_{DD}) rises above detect voltage (V_{DF}), output voltage (V_{OUT}) will be equal to V_{DD} .
(A condition of high impedance exists with Nch open drain output configurations.)
2. When input voltage (V_{DD}) falls below detect voltage (V_{DF}), output voltage (V_{OUT}) will be equal to the ground voltage (V_{SS}) level.
3. When input voltage (V_{DD}) falls to a level below that of the minimum operating voltage (V_{MIN}), output will become unstable. In this condition, V_{DD} will equal the pulled-up output (should output be pulled-up.)
4. When input voltage (V_{DD}) rises above the ground voltage (V_{SS}) level, output will be unstable at levels below the minimum operating voltage (V_{MIN}). Between the V_{MIN} and detect release voltage (V_{DR}) levels, the ground voltage (V_{SS}) level will be maintained.
5. When input voltage (V_{DD}) rises above detect release voltage (V_{DR}), output voltage (V_{OUT}) will be equal to V_{DD} .
(A condition of high impedance exists with Nch open drain output configurations.)
6. The difference between V_{DR} and V_{DF} represents the hysteresis range.

■ Timing Chart

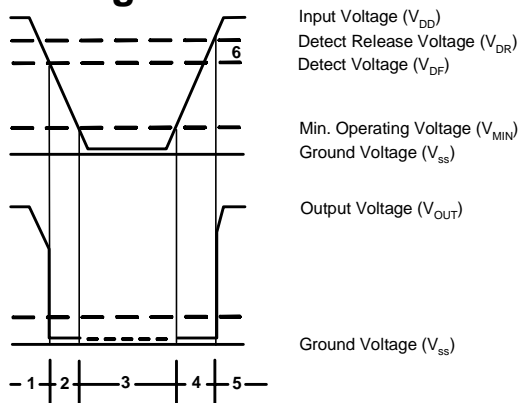

■ Functional Description (CMOS output with delay)

1. When input voltage (V_{DD}) rises above detect voltage (V_{DF}), output voltage (V_{OUT}) will be equal to V_{DD} .
(A condition of high impedance exists with Nch open drain output configurations.)
2. When input voltage (V_{DD}) falls below detect voltage (V_{DF}), output voltage (V_{OUT}) will be equal to the ground voltage (V_{SS}) level.
3. When input voltage (V_{DD}) falls to a level below that of the minimum operating voltage (V_{MIN}), output will become unstable. In this condition, V_{DD} will equal the pulled-up output (should output be pulled-up.)
4. When input voltage (V_{DD}) rises above the ground voltage (V_{SS}) level, output will be unstable at levels below the minimum operating voltage (V_{MIN}). Between the V_{MIN} and detect release voltage (V_{DR}) levels, the ground voltage (V_{SS}) level will be maintained.
5. When input voltage (V_{DD}) rises above detect release voltage (V_{DR}), output voltage (V_{OUT}) will be equal to V_{DD} after T_D delay time.

$$Q = V \times C = I \times T_D$$

$$T = \frac{V \times C}{I} \quad V = V_{REF}$$
 For Example, $T_D = \frac{V_{REF} * 1nF}{75nA}$
6. The difference between V_{DR} and V_{DF} represents the hysteresis range.

■ Timing Chart

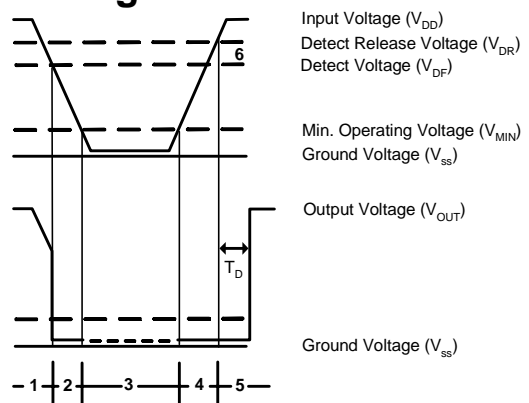

■ Notes on Use

1. When a resistor is connected between the V_{DD} pin and the input with CMOS output configurations, oscillation may occur as a result of voltage drops at R_{IN} if load current (I_{OUT}) exists. (refer to 5 - (1) below)

2. When a resistor is connected between the V_{DD} pin and the input with CMOS output configurations, irrespective of Nch output configurations, oscillation may occur as a result of through current at the time of voltage release even if load current (I_{OUT}) does not exist. (refer to 5 - (1)(2) below)

3. With a resistor connected between the V_{DD} pin and the input, detect and release voltage will rise as a result of the IC's supply current flowing through the V_{DD} pin.

4. In order to stabilise the IC's operations, please ensure that V_{DD} pin's input frequency's rise and fall times are more than several μ sec / V.

5. Oscillation

(1) Output current oscillation with the CMOS output configuration

When the voltage applied at IN rises, release operations commence and the detector's output voltage increases. Load current (I_{OUT}) will flow at R_L . Because a voltage drop ($R_{IN} \times I_{OUT}$) is produced at the R_{IN} resistor, located between the input (IN) and the V_{DD} pin, the load current will flow via the IC's V_{DD} pin. The voltage drop will also lead to a fall in the voltage level at the V_{DD} pin. When the V_{DD} pin voltage level falls below the detect voltage level, detect operations will commence. Following detect operations, load current flow will cease and since voltage drop at R_{IN} will disappear, the voltage level at the V_{DD} pin will rise and release operations will begin over again.

Oscillation may occur with this " release - detect - release " repetition.

Further, this condition will also appear via means of a similar mechanism during detect operations.

(2) Oscillation as a result of through current

Since the AME8550 series are CMOS ICs, through current will flow when the IC's internal circuit switching operates (during release and detect operations). Consequently, oscillation is liable to occur as a result of drops in voltage at the through current's resistor (R_{IN}) during release voltage operations. (refer to diagram 2)

Since hysteresis exists during detect operations, oscillation is unlikely to occur.

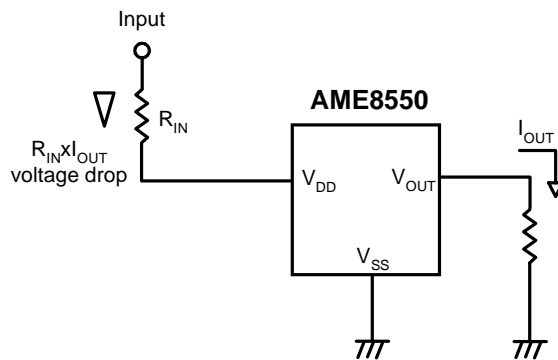

Diagram1

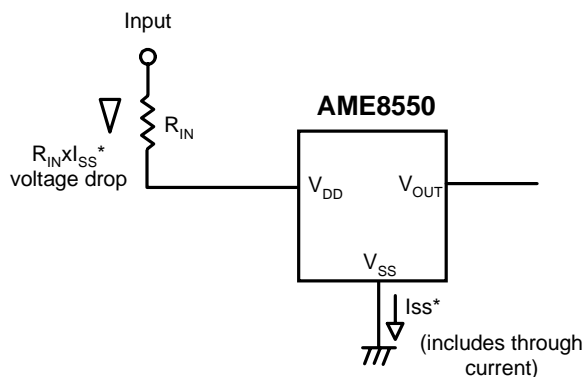
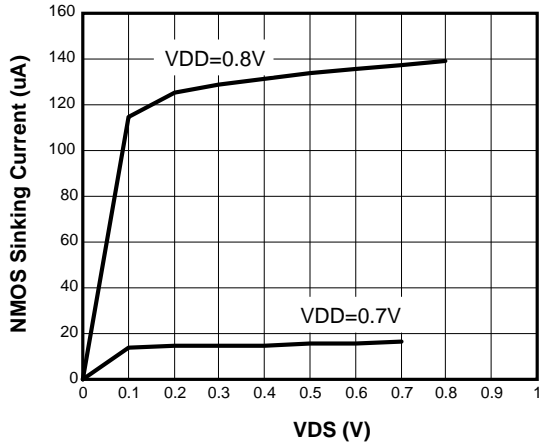

Diagram2



AME8550-1.9V



AME8550-1.9V

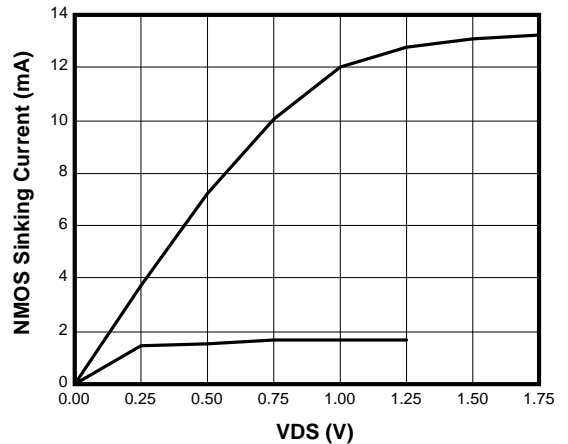

AME8550-2.7V

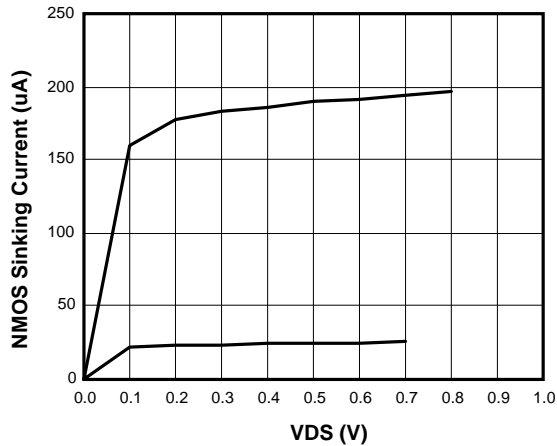

AME8550AEETA270

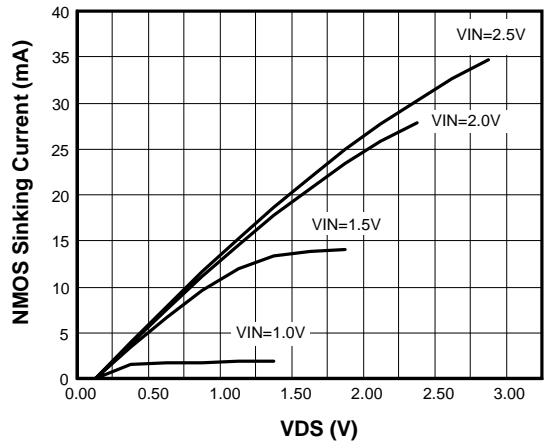

AME8550-4.6V

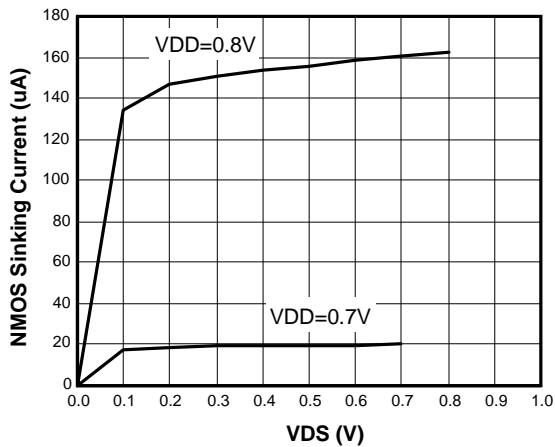

AME8550-4.6V

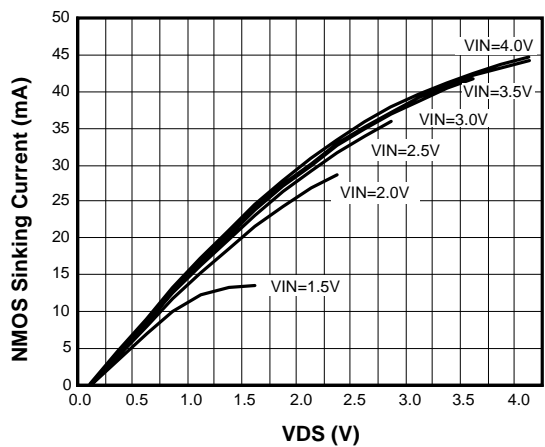



AME8550-1.9V

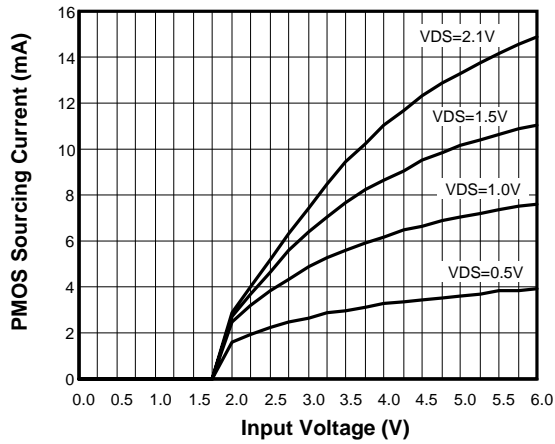

AME8550-1.9V

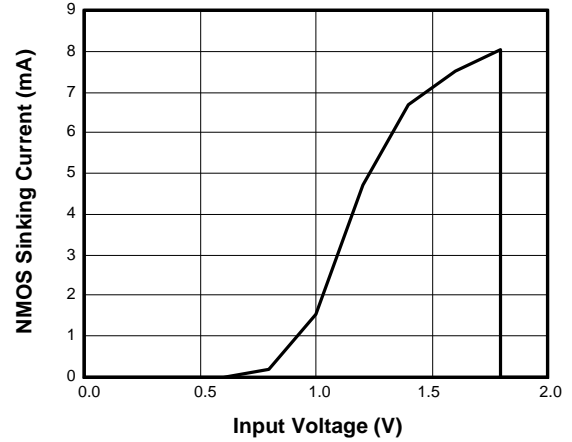

AME8550AEETA270

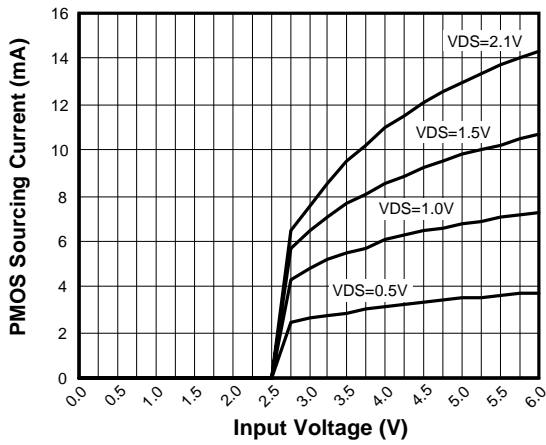

AME8550-2.7V

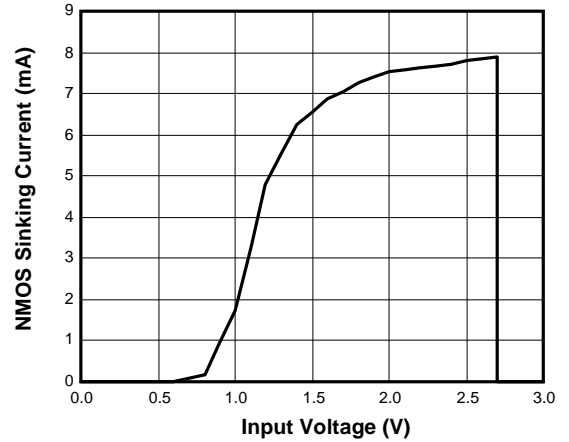

AME8550-4.6V

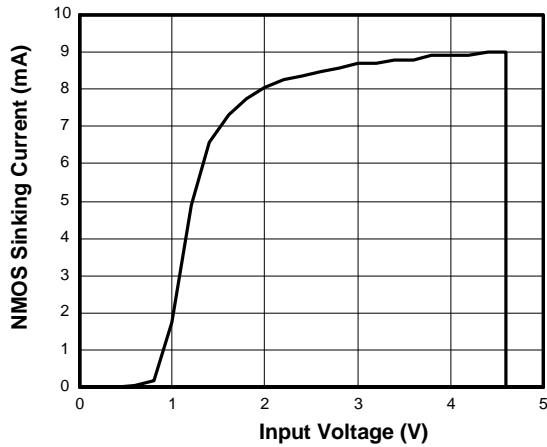

AME8550-4.6V

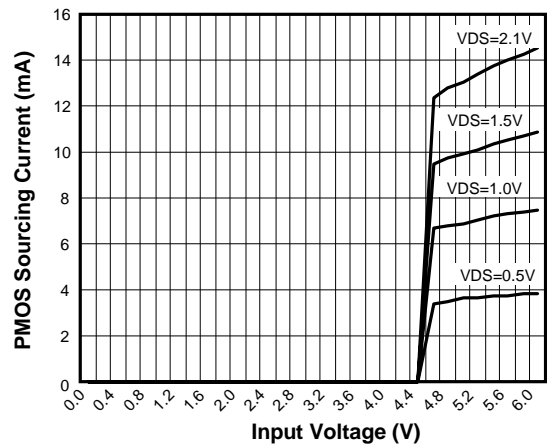



Supply Current vs. Input Voltage (2.7V)

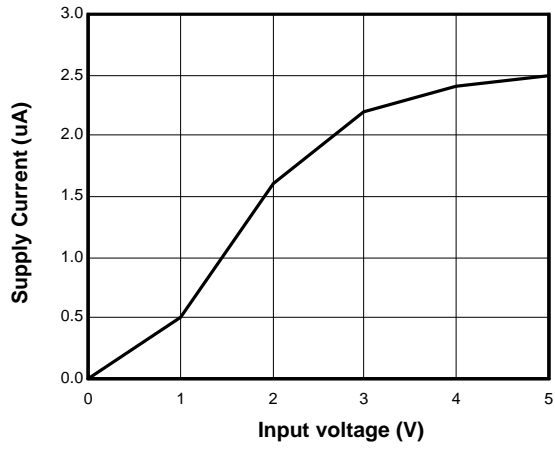

Output Voltage vs. Input Voltage (2.2V)

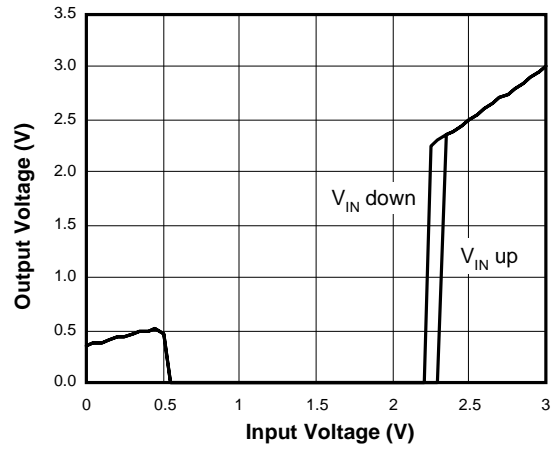

Output Voltage vs. Input Voltage (2.7V)

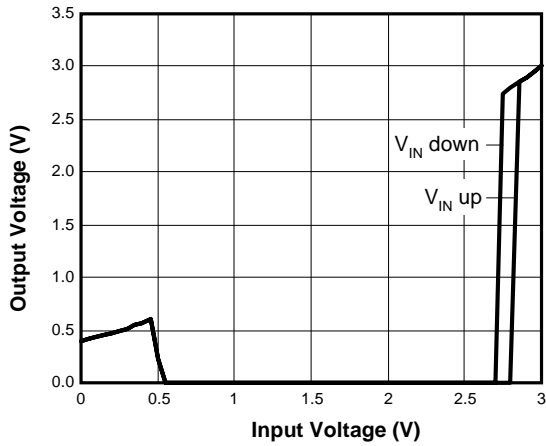

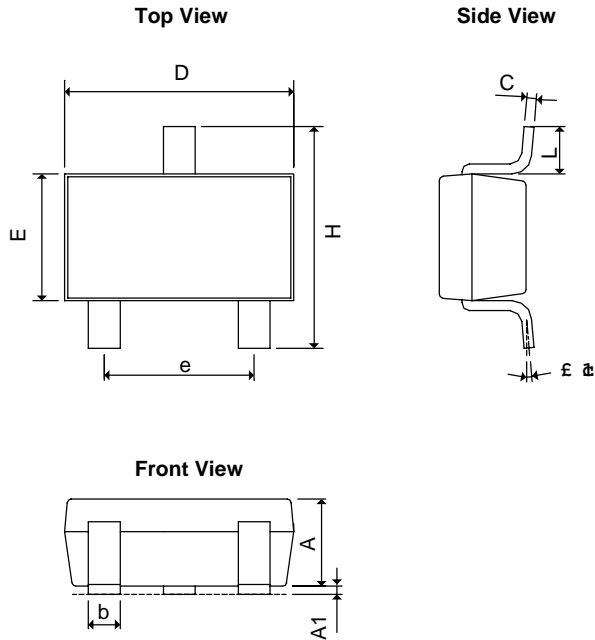
■ Package Dimension
SOT-23

SYMBOLS	MILLIMETERS		INCHES	
	MIN	MAX	MIN	MAX
A	1.00	1.40	0.0394	0.0551
A₁	0.00	0.15	0.0000	0.0059
b	0.35	0.50	0.0138	0.0197
C	0.09	0.25	0.0035	0.0098
D	2.70	3.10	0.1063	0.1220
E	1.40	1.80	0.0551	0.0709
e	1.90 BSC		0.0748 BSC	
H	2.40	3.00	0.09449	0.11811
L	0.35BSC		0.0138BSC	
θ1	0°	10°	0°	10°

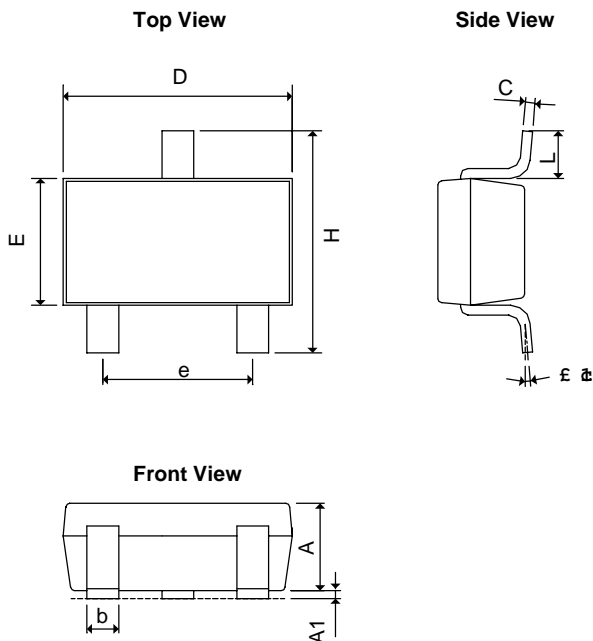
TSOT-23

SYMBOLS	MILLIMETERS		INCHES	
	MIN	MAX	MIN	MAX
A+A₁	0.80	1.30	0.0315	0.0512
b	0.35	0.50	0.0138	0.0197
C	0.08	0.25	0.0031	0.0098
D	2.70	3.10	0.1063	0.1220
E	1.20	1.80	0.0472	0.0709
e	1.90 BSC		0.0748 BSC	
H	2.40	3.00	0.09449	0.11811
L	0.35BSC		0.0138BSC	
θ1	0°	10°	0°	10°



■ Package Dimension

SOT-25

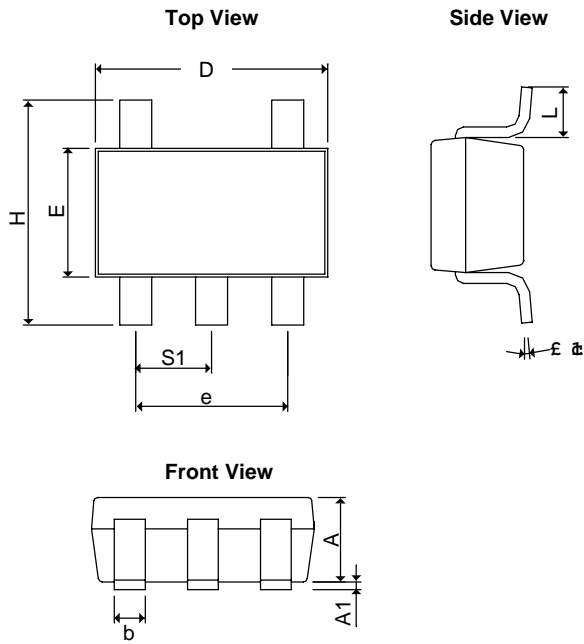

SYMBOLS	MILLIMETERS		INCHES	
	MIN	MAX	MIN	MAX
A	1.20REF		0.0472REF	
A₁	0.00	0.15	0.0000	0.0059
b	0.30	0.55	0.0118	0.0217
D	2.70	3.10	0.1063	0.1220
E	1.40	1.80	0.0551	0.0709
e	1.90 BSC		0.07480 BSC	
H	2.60	3.00	0.10236	0.11811
L	0.37BSC		0.0146BSC	
θ₁	0°	10°	0°	10°
S₁	0.95BSC		0.0374BSC	

TSOT-25

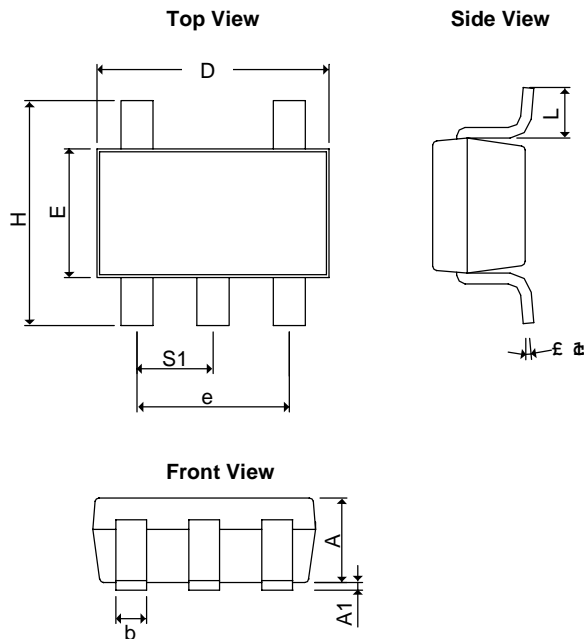

SYMBOLS	MILLIMETERS		INCHES	
	MIN	MAX	MIN	MAX
A+A₁	0.90	1.25	0.0354	0.0492
b	0.30	0.50	0.0118	0.0197
c	0.09	0.25	0.0035	0.0098
D	2.70	3.10	0.1063	0.1220
E	1.40	1.80	0.0551	0.0709
e	1.90 BSC		0.07480 BSC	
H	2.40	3.00	0.09449	0.11811
L	0.35BSC		0.0138BSC	
θ₁	0°	10°	0°	10°
S₁	0.95BSC		0.0374BSC	

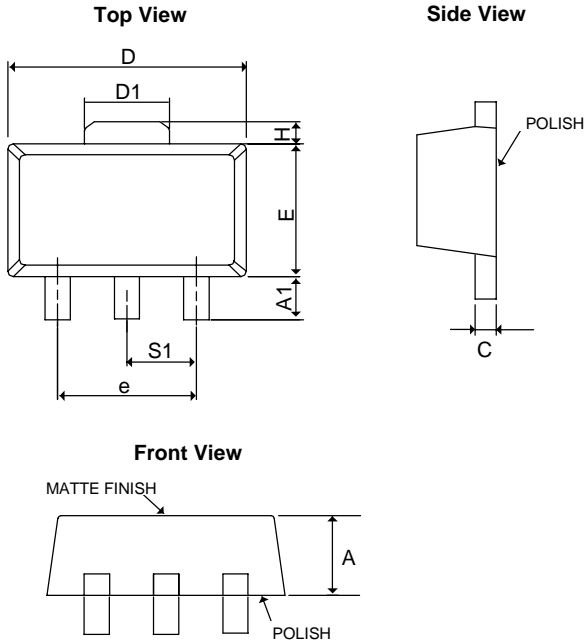
■ Package Dimension
SOT-89

SYMBOLS	MILLIMETERS		INCHES	
	MIN	MAX	MIN	MAX
A	1.39	1.60	0.05472	0.06299
A₁	0.8REF		0.0315REF	
C	0.35	0.44	0.01378	0.01732
D	4.39	4.60	0.17283	0.1811
D₁	1.35	1.83	0.05315	0.07205
E	2.28	3.60	0.08976	0.14173
e	3.00REF		0.1181REF	
H	0.70REF		0.0276REF	
S1	1.50REF		0.0590REF	



www.ame.com.tw
E-Mail: sales@ame.com.tw

Life Support Policy:

These products of AME, Inc. are not authorized for use as critical components in life-support devices or systems, without the express written approval of the president of AME, Inc.

AME, Inc. reserves the right to make changes in the circuitry and specifications of its devices and advises its customers to obtain the latest version of relevant information.

© AME, Inc. , July 2004

Document: 2051-DS8550-F

Corporate Headquarter
AME, Inc.

2F, 302 Rui-Guang Road, Nei-Hu District
Taipei 114, Taiwan, R.O.C.
Tel: 886 2 2627-8687
Fax: 886 2 2659-2989

U.S.A (Subsidiary)
Analog Microelectronics, Inc.

3100 De La Cruz Blvd., Suite 201
Santa Clara, CA. 95054-2046
Tel : (408) 988-2388
Fax: (408) 988-2489