

DATA SHEET



TZA1025

Data amplifier and laser supply
circuit for CD audio and video
optical systems (ADALASLC)

Product specification
File under Integrated Circuits, IC01

1998 Oct 30

Data amplifier and laser supply circuit for CD audio and video optical systems (ADALASLC)

TZA1025

FEATURES

- Supports a wide range of voltage output mechanisms
- RF amplifier designed for audio and video applications with 1 × data rate
- Programmable RF gain for CD-Audio/Video (CD-A/V) and CD-Read/Write (CD-R/W) discs
- Equalizer for optimal performance
- Fully Automatic Laser Power Control (ALPC) including stabilization plus a separate laser supply voltage for power efficiency
- Adjustable current range of ALPC output
- Automatic N- or P-substrate monitor diode selection
- Adjustable laser bandwidth and laser switch-on current slope using external capacitor
- Protection circuit to prevent laser damage due to laser supply voltage dip
- Optimized interconnection between data amplifier and Philips' digital signal processor CD10LC (SAA7325)
- Wide supply voltage range
- Power-down switch to reduce power consumption during standby
- Low power consumption.

GENERAL DESCRIPTION

The TZA1025 is a data amplifier and laser supply circuit for voltage output mechanisms found in a wide range of audio and video CD systems. The device contains an RF amplifier and an automatic laser power control circuit.

The preamplifier forms an interface for voltage output CD mechanisms to the Philips' digital signal processor CD10LC (SAA7325).

ORDERING INFORMATION

TYPE NUMBER	PACKAGE		
	NAME	DESCRIPTION	VERSION
TZA1025T	SO14	plastic small outline package; 14 leads; body width 3.9 mm	SOT108-1



The RF bandwidth allows this device to be used in CD-A/V applications with a data rate of $n = 1$ times speed. The RF gain can be adapted for CD-A/V discs or CD-R/W discs by means of the gain select signal.

The equalizer ensures an optimal performance.

The TZA1025 can be adapted to a wide range of voltage output mechanisms by means of external resistors.

The ALPC circuit will maintain control over the laser diode current. With an on-chip reference voltage generator, a constant and stabilized output power is ensured independent of ageing. The ALPC can accommodate N- or P-substrate monitor diodes.

A separate supply voltage connection for the laser allows the internal power dissipation to be reduced by connecting a low voltage supply. The laser output current range can be optimized to fit the requirements of the laser diode by means of one external resistor. When a DC-to-DC converter is used, in combination with the control loop of the ALPC, the adjustable output current range provides the possibility to compensate for the extra gain a DC-to-DC converter introduces in the control loop.

Data amplifier and laser supply circuit for CD audio and video optical systems (ADALASLC)

TZA1025

QUICK REFERENCE DATA

SYMBOL	PARAMETER	CONDITIONS	MIN.	TYP.	MAX.	UNIT
Supplies						
V_{DD}	supply voltage		2.4	–	5.5	V
I_{DD}	supply current		–	3	–	mA
$V_{DD(L)}$	laser supply voltage		2.4	–	5.5	V
RF amplifier						
$t_{d(f)(RF)}$	RF flatness delay		–	–	10	ns
Laser supply circuit						
$I_{o(LASER)(max)}$	maximum laser output current	$V_{DD(L)} - V_{o(LASER)} = 0.55\text{ V}$	80	–	–	mA
$V_{i(mon)}$	monitor input voltage		–	0.150	–	V
	N-substrate monitor diode		–	$V_{DD} - 0.150$	–	V
Temperature range						
T_{amb}	operating ambient temperature		0	–	70	°C

BLOCK DIAGRAM

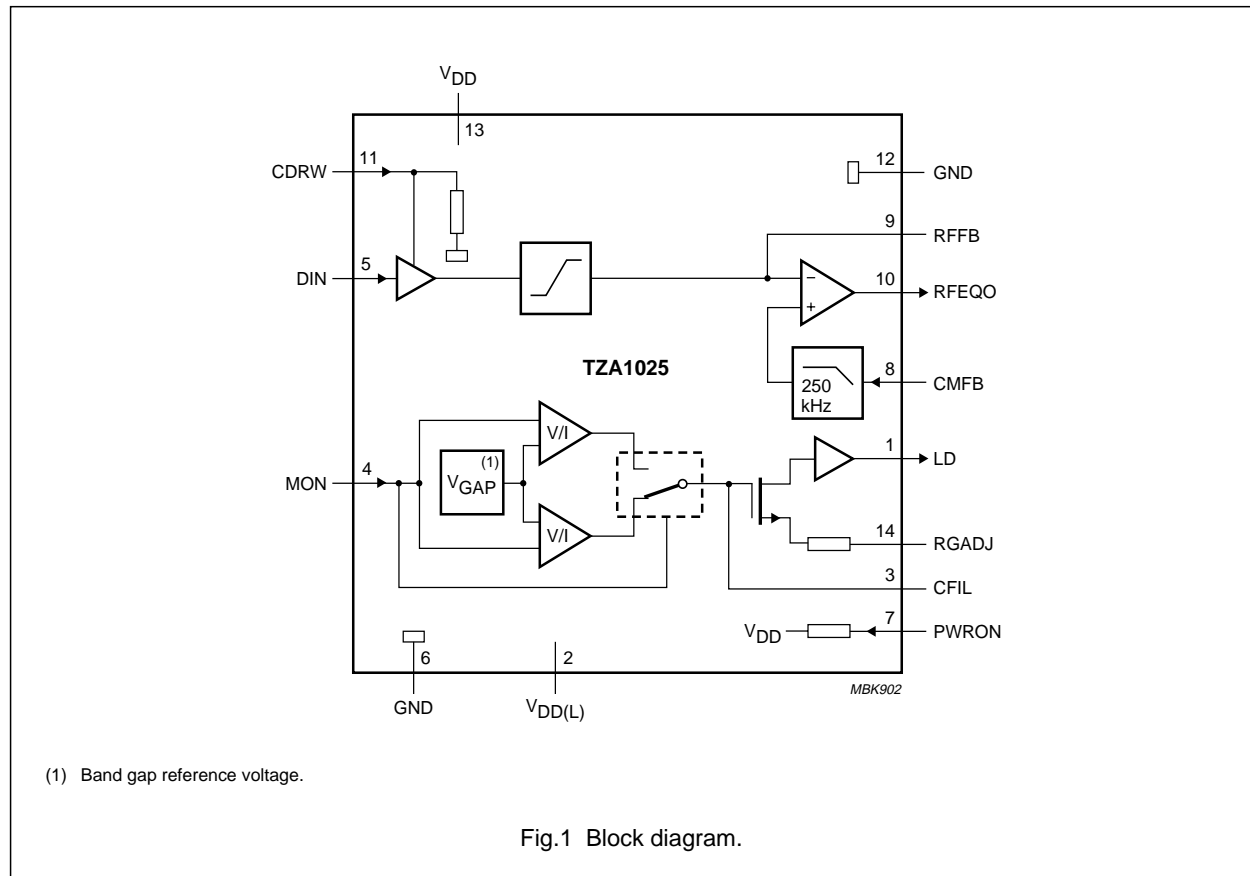

Data amplifier and laser supply circuit for CD audio and video optical systems (ADALASLC)

TZA1025

PINNING

SYMBOL	PIN	DESCRIPTION
LD	1	current output to laser diode
V _{DD(L)}	2	laser supply voltage
CFIL	3	external filter capacitor
MON	4	laser monitor diode input
DIN	5	central diode input
GND	6	ground
PWRON	7	power-on select input
CMFB	8	common mode feedback voltage input
RFFB	9	external RF feedback resistor
RFEQO	10	RF amplifier output
CDRW	11	gain select input for CD-A/V, CD-R/W
GND	12	ground
V _{DD}	13	supply voltage
RGADJ	14	external laser supply gain adjust resistor

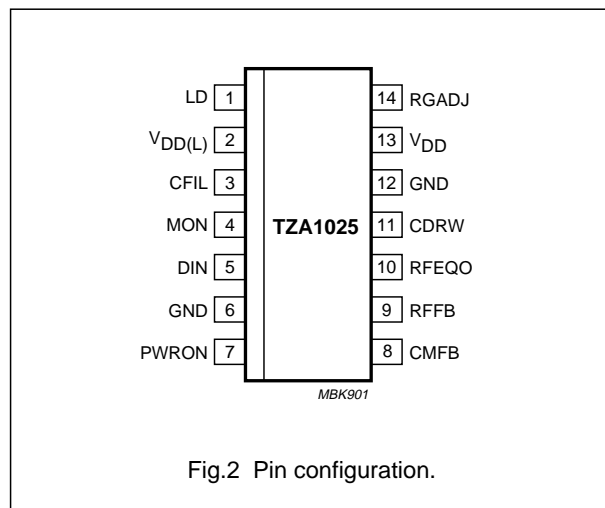

FUNCTIONAL DESCRIPTION

The TZA1025 consists of two sections, the RF amplifier and the automatic laser power control circuit.

RF amplifier

The RF amplifier consists of a current input amplifier, an equalizer/bandwidth section and a transimpedance output amplifier with an external feedback resistor of 10 kΩ (fixed value).

The gain of the RF amplifier can be adjusted by the external input resistors. Fig.3 shows the simplified schematic which can be used to determine the RF gain. The signal is AC coupled to the RF amplifier. The formula to determine the gain is shown below:

$$G_{RF} = -n \times \frac{Z_{tr(RF)}}{R2} \quad (1)$$

where:

G_{RF} is the RF amplifier gain

n is the number of input resistors

$Z_{tr(RF)}$ is the transimpedance of the amplifier (Ω)

$R2$ is the value of the input resistors (Ω).

The gain can be increased by a factor of 4 by making pin CDRW HIGH. The value of $Z_{tr(RF)}$ is 9.8 kΩ for CD-A/V (CDRW = LOW) and 38 kΩ for CD-R/W (CDRW = HIGH).

An internal equalizer ensures an optimal performance.

The DC output level of the amplifier can be set by applying a DC voltage on the common mode feedback pin CMFB. Since the input signal is AC-coupled the RF output voltage will swing (symmetrically) around this DC level.

The coupling of the TZA1025 to the signal processor (SAA7325) can be either AC or DC. When an AC-coupling is chosen (see Fig.6) the minimum supply voltage can be applied. When a DC-coupling is chosen (see Fig.7) a minimum supply voltage of 2.8 V is required.

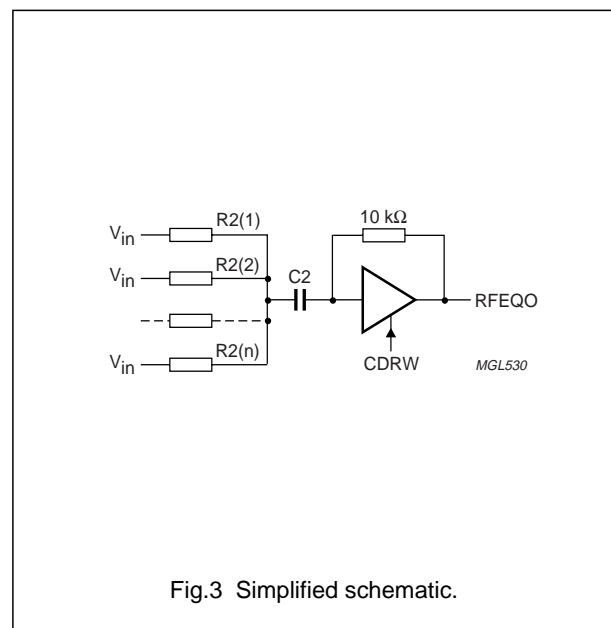

Data amplifier and laser supply circuit for CD audio and video optical systems (ADALASLC)

TZA1025

Automatic laser power control circuit

The ALPC stabilises the laser output power thereby reducing the effect of ageing of the laser.

The TZA1025 automatically detects when an N- or P-substrate monitor diode is used and selects the correct reference voltage. A simplified diagram for the use of an N- or P-substrate monitor diode is given in Fig.4.

The gain of the loop can be controlled (reduced) by adding an external resistor between pins RGADJ and GND. The loop gain then becomes:

$$G_{\text{loop}} = G_{\text{ALPC}} \times G_{\text{lm}} \times G_{\text{con}} \times \frac{250}{250 + R_{\text{RGADJ}}} \quad (2)$$

where:

G_{loop} is the loop gain

G_{ALPC} is the ALPC transfer (60 A/V)

G_{lm} is the laser-to-monitor transfer (V/A)

G_{con} is the extra gain introduced when a DC-to-DC converter is used in the loop; $G_{\text{con}} = 1$ when no DC-to-DC converter is used

250 is a fixed internal resistor value (Ω)

R_{RGADJ} is the value of the external resistor (Ω).

The minimum available output current is also reduced when an external resistor is used. The formula to determine the minimum available output current is shown in equation (3).

$$I_o = I_{o(\text{LASER})(\text{max})} \times \frac{250}{250 + R_{\text{RGADJ}}} \quad (3)$$

where:

I_o is output current (mA)

$I_{o(\text{LASER})(\text{max})}$ is the maximum laser output current (mA)

250 is a fixed internal resistor value (Ω)

R_{RGADJ} is the value of the external resistor (Ω).

The bandwidth of the loop is determined by the external filter capacitor C_{CFIL} and the loop gain. The formula to determine the bandwidth is shown in equation (4).

$$\tau_{-3\text{dB}} = \frac{C_{\text{CFIL}} \times 16 \cdot 10^6}{G_{\text{loop}}} \quad (4)$$

where:

C_{CFIL} is the value of the capacitor (F)

G_{loop} is the loop gain.

The TZA1025 has a protection circuit to prevent laser damage that can occur due to a dip of $V_{\text{DD(L)}}$. When a dip occurs the output transistor (see Fig.4) will go into saturation making it unable to supply the required laser current. Without the protection circuit the ALPC would still try to supply the required laser current by charging the filter capacitor C_{CFIL} . After the dip a fully charged capacitor would create a large output current during the few milliseconds it needs to discharge the capacitor to a normal level. The protection circuit monitors the output transistor and switches off the ALPC when saturation occurs by discharging the capacitor. The ALPC will automatically restart within a few milliseconds after the dip has passed.

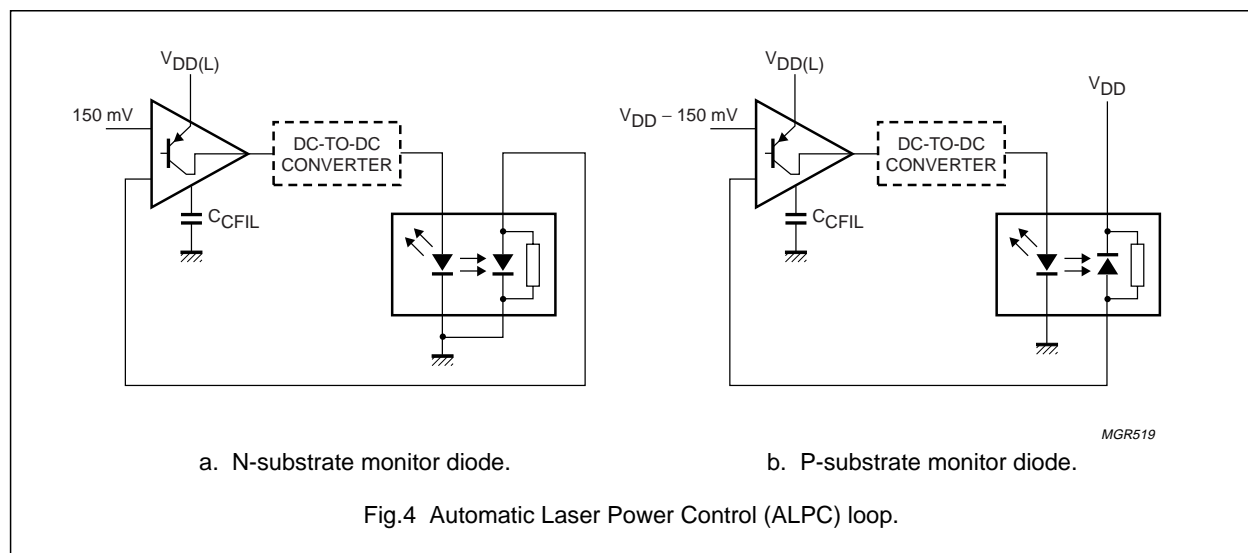

Data amplifier and laser supply circuit for CD audio and video optical systems (ADALASLC)

TZA1025

LIMITING VALUES

In accordance with the Absolute Maximum Rating System (IEC 134).

SYMBOL	PARAMETER	CONDITIONS	MIN.	MAX.	UNIT
V_{DD}	supply voltage		-0.5	+5.5	V
$V_{DD(L)}$	laser supply voltage		-0.5	+5.5	V
$V_{i(n)}$	input voltage on pins 3, 4, 7, 8, 10, 11, 12 and 14	note 1	-0.5	$V_{DD} + 0.5$	V
$V_{o(LASER)}$	laser output voltage	note 2	-0.5	$V_{DD(L)} + 0.5$	V
$V_{i(DIN)}$	central diode input voltage	note 3	-0.5	-	V
$I_{i(DIN)}$	central diode input current	note 4	-1	+1	mA
$V_{i(RFFB)}$	RF feedback voltage	note 3	-0.5	-	V
$I_{i(RFFB)}$	RF feedback current	note 4	-1	+1	mA
V_{es}	electrostatic handling	human body model; note 5	-2000	+2000	V
		machine model; note 6	-250	+250	V
T_{amb}	operating ambient temperature		0	70	°C

Notes

1. The maximum value $V_{DD} + 0.5$ must not exceed 5.5 V.
2. The maximum value $V_{DD(L)} + 0.5$ must not exceed 5.5 V.
3. Pins DIN and RFFB are current inputs with a limitation on the maximum input current.
4. The maximum peak current must not exceed ten times the absolute average input current with a maximum for the absolute average input current of 1 mA. Averaging is only allowed over a maximum time interval of 100 ms.
5. Equivalent to discharging a 100 pF capacitor via a 1.5 k Ω series resistor with a rise time of 15 ns.
6. Equivalent to discharging a 200 pF capacitor via a 2.5 μ H series inductor.

QUALITY SPECIFICATION

In accordance with "SNW-FQ-611-E".

Data amplifier and laser supply circuit for CD audio and video optical systems (ADALASLC)

TZA1025

CHARACTERISTICS

$V_{DD} = 2.4 \text{ V}$; $V_{DD(L)} - V_{O(LASER)} = 0.55 \text{ V}$; $I_{i(DIN)} = 0 \text{ mA}$; $I_{O(LASER)} = 80 \text{ mA}$; $V_{CMFB} = \frac{1}{2}V_{DD}$; $PWRON = \text{HIGH}$; $CDRW = \text{LOW}$; $C_{CFIL} = 10 \text{ nF}$; $R_{RFFB} = 10 \text{ k}\Omega$; pin RGADJ connected to ground; $T_{amb} = 25 \text{ }^\circ\text{C}$; unless otherwise specified.

SYMBOL	PARAMETER	CONDITIONS	MIN.	TYP.	MAX.	UNIT
Supplies						
V_{DD}	supply voltage		2.4	–	5.5	V
$V_{DDL(L)}$	laser supply voltage		2.4	–	5.5	V
I_{DD}	supply current		–	3	–	mA
I_q	quiescent supply current	$PWRON = \text{LOW}$	–	–	40	μA
RF amplifier						
$I_{i(DIN)}$	central diode input current		–70	–	+70	μA
$Z_{i(DIN)}$	central diode input impedance		–	100	–	Ω
V_{CMFB}	common mode feedback input voltage		0.7	$\frac{1}{2}V_{DD}$	$V_{DD} - 0.4$	V
$V_{O(RFEQO)}$	RF amplifier output DC-level	$CDRW = \text{LOW}$	$V_{CMFB} - 0.05$	–	$V_{CMFB} + 0.25$	V
		$CDRW = \text{HIGH}$	$V_{CMFB} - 0.35$	–	$V_{CMFB} + 0.35$	V
$V_{O(RFEQO)}$	RF amplifier output voltage		0.25	–	$V_{DD} - 0.25$	V
$Z_{O(RFEQO)}$	RF amplifier output impedance	note 1	–	100	–	Ω
$t_{d(f)(RF)}$	RF flatness delay		–	–	10	ns
G_{RF}	RF path gain boost	$f = 720 \text{ kHz}$; note 2	–	5	–	dB
$Z_{tr(RF)}$	RF transimpedance	note 3				
		$CDRW = \text{LOW}$	9.2	9.8	10.4	k Ω
		$CDRW = \text{HIGH}$	35.6	38	40.4	k Ω
THD_{RF}	RF total harmonic distortion	note 4	–	–50	–	dB
$PSRR_{RF}$	RF power supply ripple rejection	0 to 100 kHz	–	40	–	dB
$V_{n(\text{in-band})(rms)}$	in-band noise (RMS value)	note 4	–	2.7	–	mV
Laser supply circuit						
V_{drop}	drop voltage	note 5	0.55	–	5.5	V
$I_{O(LASER)(max)}$	maximum laser output current	$V_{drop} = 0.55 \text{ V}$; note 6	80	–	–	mA
$Z_{O(LASER)}$	laser output impedance	$V_{drop} = 0.55 \text{ V}$; note 7				
		$I_{O(LASER)} = 53 \text{ mA}$	–	500	–	Ω
		$I_{O(LASER)} = 20 \text{ mA}$	–	1200	–	Ω

Data amplifier and laser supply circuit for CD audio and video optical systems (ADALASLC)

TZA1025

SYMBOL	PARAMETER	CONDITIONS	MIN.	TYP.	MAX.	UNIT
$V_{i(\text{mon})}$	monitor input voltage					
	N-substrate		0.132	0.150	0.168	V
	P-substrate		$V_{DD} - 0.168$	$V_{DD} - 0.150$	$V_{DD} - 0.132$	V
$I_{i(\text{mon})}$	monitor input current		-200	-	+200	nA
$t_{\text{sw(ON)(LASER)}}$	laser switch-on time		-	3	-	ms
RS_{ref}	reference supply rejection	note 8	-	-	5	%
V_{clamp}	ALPC clamp voltage	note 9	-	-	0.5	V
Control inputs						
$Z_{i(\text{pd})}$	pull-down input impedance pin CDRW		-	200	-	k Ω
$Z_{i(\text{pu})}$	pull-up input impedance pin PWRON		-	200	-	k Ω
V_{IL}	LOW-level input voltage					
	pin CDRW		-0.2	-	$\frac{1}{3}V_{DD}$	V
	pin PWRON		-0.2	-	$\frac{1}{3}V_{DD}$	V
V_{IH}	HIGH-level input voltage					
	pin CDRW		$\frac{2}{3}V_{DD}$	-	$V_{DD} + 0.2$	V
	pin PWRON		$\frac{2}{3}V_{DD}$	-	$V_{DD} + 0.2$	V

Notes

- Closed-loop output impedance (10 k Ω feedback resistor connected between pins RFEQO and RFFB).
- $G_{\text{RF}} = (G_{\text{RFEQO}} \text{ at } f_{\text{EQ}}) - (G_{\text{RFEQO}} \text{ at } 720 \text{ kHz})$.
- Values to be used in equation (1).
- An RF filter of 1 k Ω and 47 pF should be used on the RF output.
- $V_{\text{drop}} = V_{\text{DD(L)}} - V_{\text{o(LASER)}}$.
- An external resistor can be used to reduce the maximum output current (and the gain) of the laser supply; see equation (4).
- The output impedance strongly depends on the drop voltage (V_{drop}). The output impedance will approximately double when the drop voltage doubles.

$$8. \quad RS_{\text{ref}} = \frac{\frac{\Delta V_{\text{mon}}}{V_{\text{mon}}}}{\frac{\Delta V_{\text{DD}}}{V_{\text{DD}}}}$$

- When a voltage dip at $V_{\text{DD(L)}}$ occurs it could cause peak currents on $I_{\text{o(LASER)}}$ coming out of the ALPC output. To protect the laser against such peak currents a protection circuit will switch-off the laser current when V_{drop} becomes lower than V_{clamp} . When $V_{\text{drop}} > V_{\text{clamp}}$ the laser will switch-on automatically again.

Data amplifier and laser supply circuit for CD audio and video optical systems (ADALASLC)

TZA1025

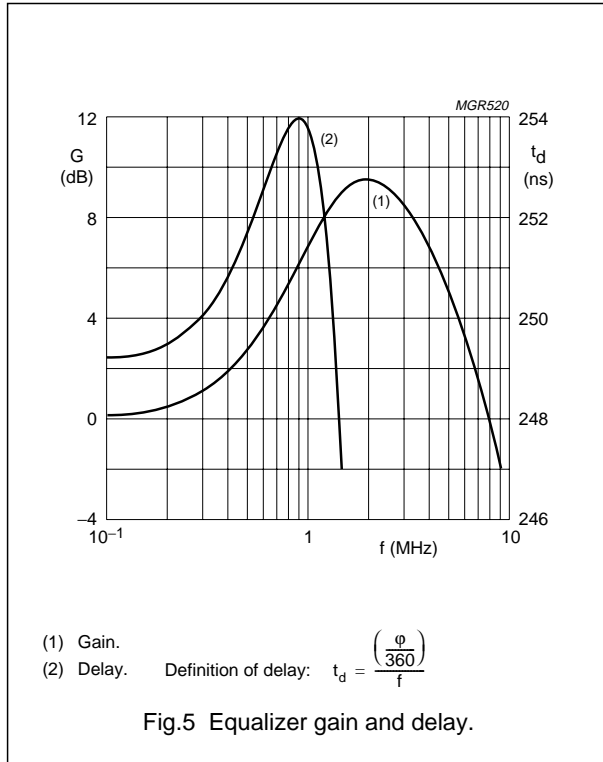

Data amplifier and laser supply circuit for CD audio and video optical systems (ADALASLC)

TZA1025

APPLICATION INFORMATION

The application for the TZA1025 (ADALASLC) with the SAA7325 (CD10LC) using a coupling capacitor of 3.3 nF is shown in Fig.6.

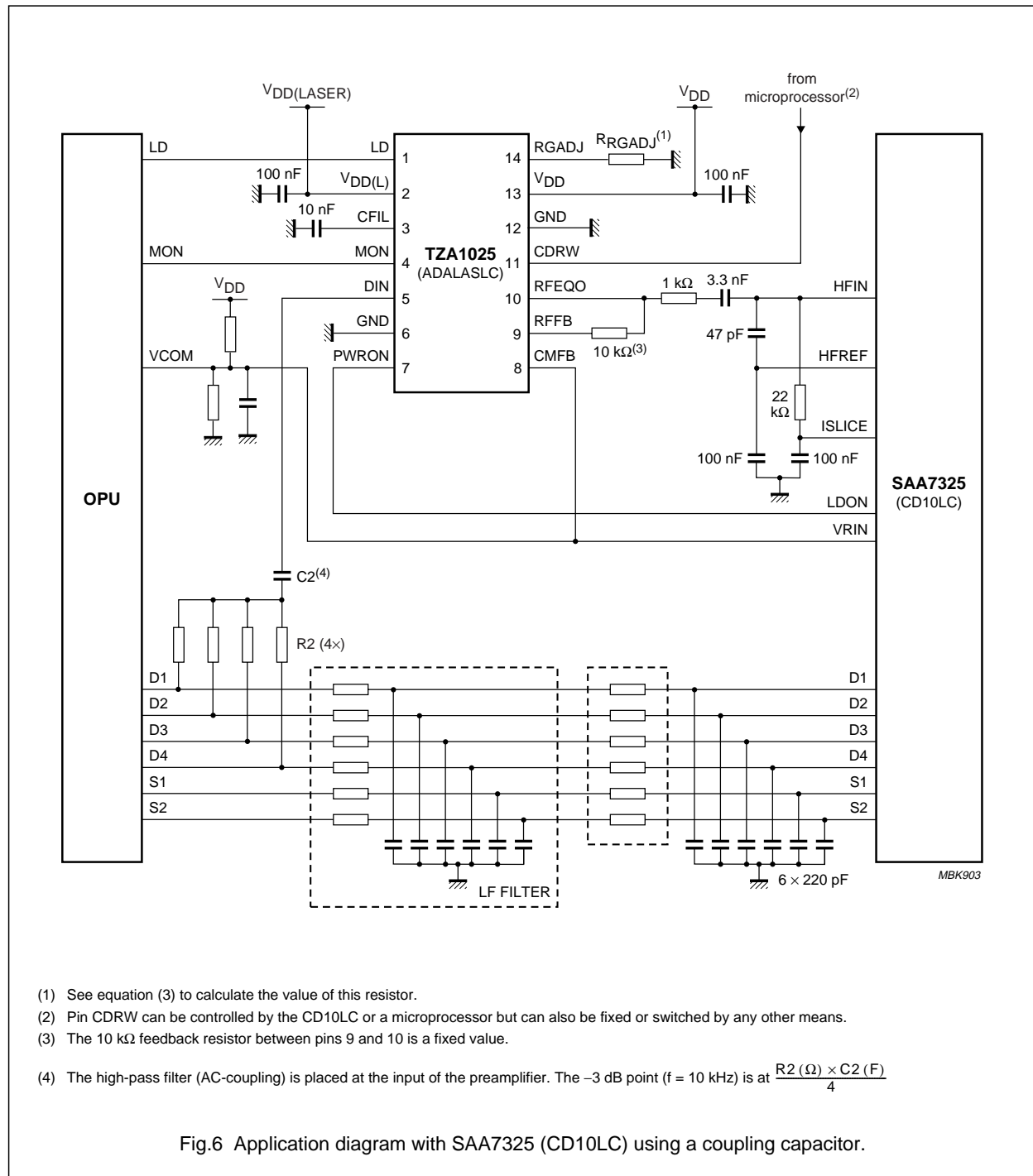

Data amplifier and laser supply circuit for CD audio and video optical systems (ADALASLC)

TZA1025

The application for the TZA1025 (ADALASLC) with the SAA7325 (CD10LC) without a coupling capacitor is shown in Fig.7. A minimum supply voltage (V_{DD}) is required for optimal performance.

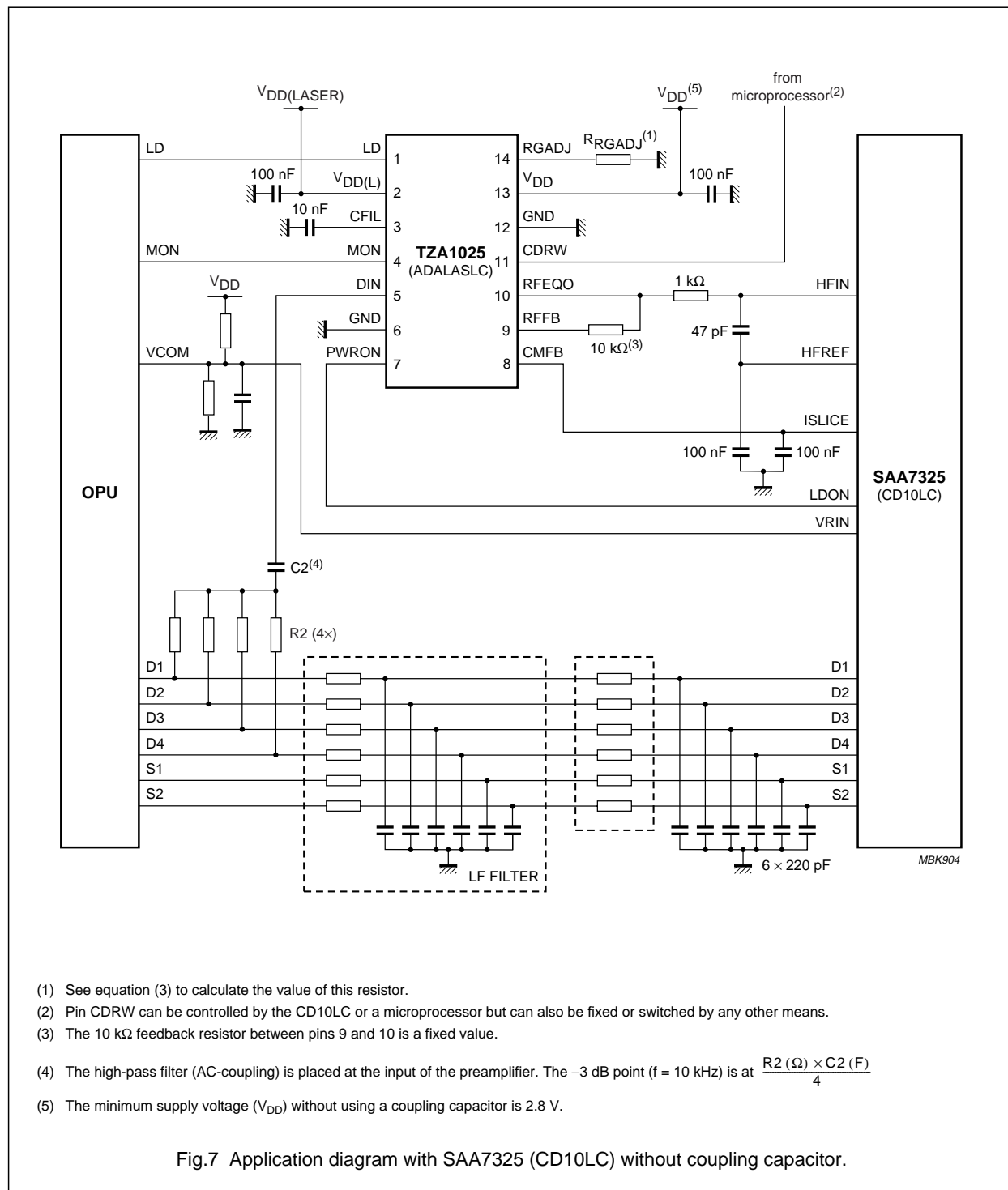

Data amplifier and laser supply circuit for CD audio and video optical systems (ADALASLC)

TZA1025

PACKAGE OUTLINE

SO14: plastic small outline package; 14 leads; body width 3.9 mm

SOT108-1

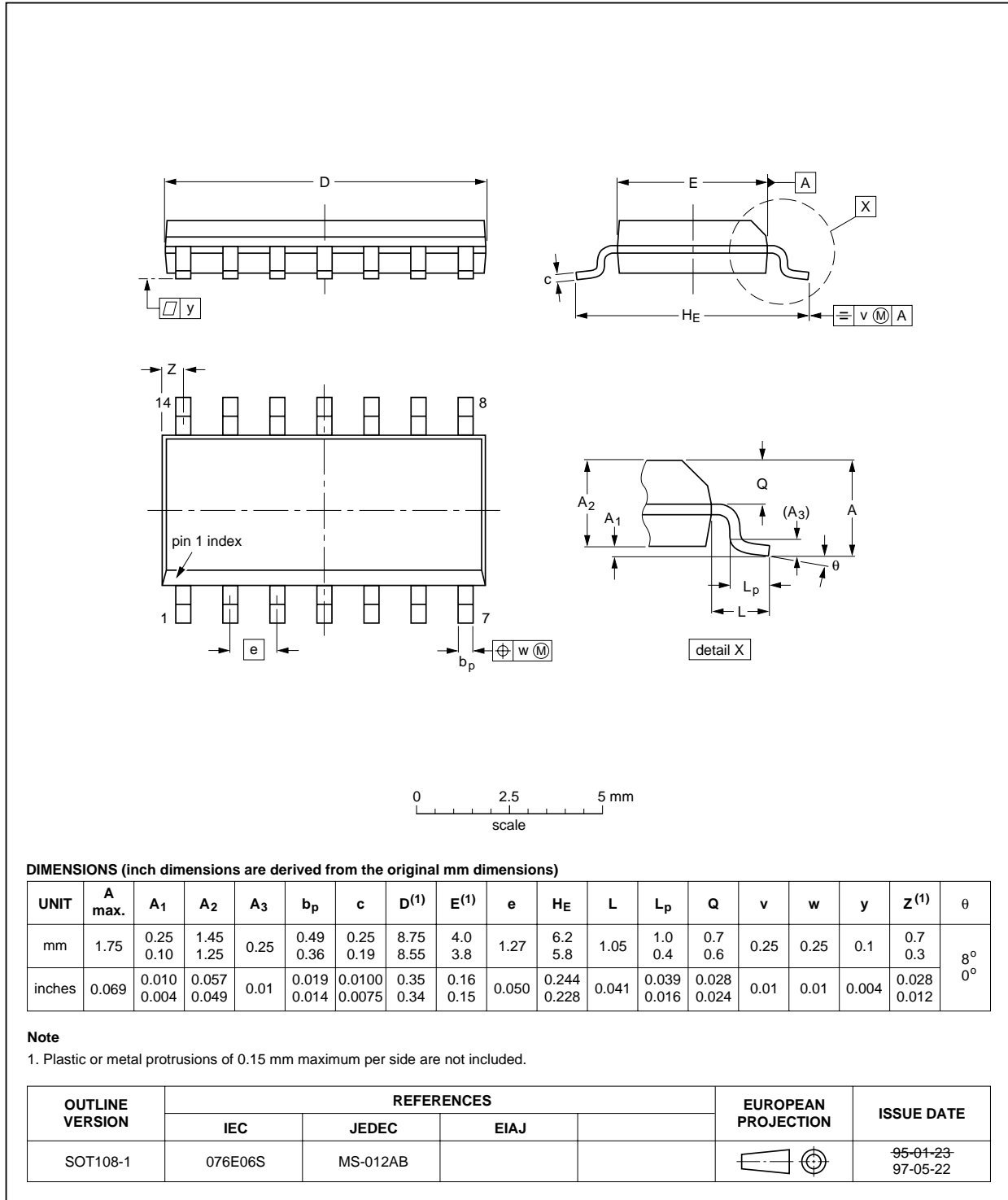

Data amplifier and laser supply circuit for CD audio and video optical systems (ADALASLC)

TZA1025

SOLDERING

Introduction

There is no soldering method that is ideal for all IC packages. Wave soldering is often preferred when through-hole and surface mounted components are mixed on one printed-circuit board. However, wave soldering is not always suitable for surface mounted ICs, or for printed-circuits with high population densities. In these situations reflow soldering is often used.

This text gives a very brief insight to a complex technology. A more in-depth account of soldering ICs can be found in our *"Data Handbook IC26; Integrated Circuit Packages"* (order code 9398 652 90011).

Reflow soldering

Reflow soldering techniques are suitable for all SO packages.

Reflow soldering requires solder paste (a suspension of fine solder particles, flux and binding agent) to be applied to the printed-circuit board by screen printing, stencilling or pressure-syringe dispensing before package placement.

Several techniques exist for reflowing; for example, thermal conduction by heated belt. Dwell times vary between 50 and 300 seconds depending on heating method. Typical reflow temperatures range from 215 to 250 °C.

Preheating is necessary to dry the paste and evaporate the binding agent. Preheating duration: 45 minutes at 45 °C.

Wave soldering

Wave soldering techniques can be used for all SO packages if the following conditions are observed:

- A double-wave (a turbulent wave with high upward pressure followed by a smooth laminar wave) soldering technique should be used.
- The longitudinal axis of the package footprint must be parallel to the solder flow.
- The package footprint must incorporate solder thieves at the downstream end.

During placement and before soldering, the package must be fixed with a droplet of adhesive. The adhesive can be applied by screen printing, pin transfer or syringe dispensing. The package can be soldered after the adhesive is cured.

Maximum permissible solder temperature is 260 °C, and maximum duration of package immersion in solder is 10 seconds, if cooled to less than 150 °C within 6 seconds. Typical dwell time is 4 seconds at 250 °C.

A mildly-activated flux will eliminate the need for removal of corrosive residues in most applications.

Repairing soldered joints

Fix the component by first soldering two diagonally-opposite end leads. Use only a low voltage soldering iron (less than 24 V) applied to the flat part of the lead. Contact time must be limited to 10 seconds at up to 300 °C. When using a dedicated tool, all other leads can be soldered in one operation within 2 to 5 seconds between 270 and 320 °C.

Data amplifier and laser supply circuit for CD audio and video optical systems (ADALASLC)

TZA1025

DEFINITIONS

Data sheet status	
Objective specification	This data sheet contains target or goal specifications for product development.
Preliminary specification	This data sheet contains preliminary data; supplementary data may be published later.
Product specification	This data sheet contains final product specifications.
Limiting values	
Limiting values given are in accordance with the Absolute Maximum Rating System (IEC 134). Stress above one or more of the limiting values may cause permanent damage to the device. These are stress ratings only and operation of the device at these or at any other conditions above those given in the Characteristics sections of the specification is not implied. Exposure to limiting values for extended periods may affect device reliability.	
Application information	
Where application information is given, it is advisory and does not form part of the specification.	

LIFE SUPPORT APPLICATIONS

These products are not designed for use in life support appliances, devices, or systems where malfunction of these products can reasonably be expected to result in personal injury. Philips customers using or selling these products for use in such applications do so at their own risk and agree to fully indemnify Philips for any damages resulting from such improper use or sale.

Data amplifier and laser supply circuit for CD
audio and video optical systems (ADALASLC)

TZA1025

NOTES

Philips Semiconductors – a worldwide company

Argentina: see South America

Australia: 34 Waterloo Road, NORTH RYDE, NSW 2113,
Tel. +61 2 9805 4455, Fax. +61 2 9805 4466

Austria: Computerstr. 6, A-1101 WIEN, P.O. Box 213, Tel. +43 160 1010,
Fax. +43 160 101 1210

Belarus: Hotel Minsk Business Center, Bld. 3, r. 1211, Volodarski Str. 6,
220050 MINSK, Tel. +375 172 200 733, Fax. +375 172 200 773

Belgium: see The Netherlands

Brazil: see South America

Bulgaria: Philips Bulgaria Ltd., Energoproject, 15th floor,
51 James Bouchier Blvd., 1407 SOFIA,
Tel. +359 2 689 211, Fax. +359 2 689 102

Canada: PHILIPS SEMICONDUCTORS/COMPONENTS,
Tel. +1 800 234 7381

China/Hong Kong: 501 Hong Kong Industrial Technology Centre,
72 Tat Chee Avenue, Kowloon Tong, HONG KONG,
Tel. +852 2319 7888, Fax. +852 2319 7700

Colombia: see South America

Czech Republic: see Austria

Denmark: Prags Boulevard 80, PB 1919, DK-2300 COPENHAGEN S,
Tel. +45 32 88 2636, Fax. +45 31 57 0044

Finland: Sinikalliontie 3, FIN-02630 ESPOO,
Tel. +358 9 615800, Fax. +358 9 61580920

France: 51 Rue Carnot, BP317, 92156 SURESNES Cedex,
Tel. +33 1 40 99 6161, Fax. +33 1 40 99 6427

Germany: Hammerbrookstraße 69, D-20097 HAMBURG,
Tel. +49 40 23 53 60, Fax. +49 40 23 536 300

Greece: No. 15, 25th March Street, GR 17778 TAVROS/ATHENS,
Tel. +30 1 4894 339/239, Fax. +30 1 4814 240

Hungary: see Austria

India: Philips INDIA Ltd, Band Box Building, 2nd floor,
254-D, Dr. Annie Besant Road, Worli, MUMBAI 400 025,
Tel. +91 22 493 8541, Fax. +91 22 493 0966

Indonesia: PT Philips Development Corporation, Semiconductors Division,
Gedung Philips, Jl. Buncit Raya Kav.99-100, JAKARTA 12510,
Tel. +62 21 794 0040 ext. 2501, Fax. +62 21 794 0080

Ireland: Newstead, Clonskeagh, DUBLIN 14,
Tel. +353 1 7640 000, Fax. +353 1 7640 200

Israel: RAPAC Electronics, 7 Kehilat Saloniki St, PO Box 18053,
TEL AVIV 61180, Tel. +972 3 645 0444, Fax. +972 3 649 1007

Italy: PHILIPS SEMICONDUCTORS, Piazza IV Novembre 3,
20124 MILANO, Tel. +39 2 6752 2531, Fax. +39 2 6752 2557

Japan: Philips Bldg 13-37, Kohnan 2-chome, Minato-ku,
TOKYO 108-8507, Tel. +81 3 3740 5130, Fax. +81 3 3740 5077

Korea: Philips House, 260-199 Itaewon-dong, Yongsan-ku, SEOUL,
Tel. +82 2 709 1412, Fax. +82 2 709 1415

Malaysia: No. 76 Jalan Universiti, 46200 PETALING JAYA, SELANGOR,
Tel. +60 3 750 5214, Fax. +60 3 757 4880

Mexico: 5900 Gateway East, Suite 200, EL PASO, TEXAS 79905,
Tel. +9-5 800 234 7381

Middle East: see Italy

Netherlands: Postbus 90050, 5600 PB EINDHOVEN, Bldg. VB,
Tel. +31 40 27 82785, Fax. +31 40 27 88399

New Zealand: 2 Wagener Place, C.P.O. Box 1041, AUCKLAND,
Tel. +64 9 849 4160, Fax. +64 9 849 7811

Norway: Box 1, Manglerud 0612, OSLO,
Tel. +47 22 74 8000, Fax. +47 22 74 8341

Pakistan: see Singapore

Philippines: Philips Semiconductors Philippines Inc.,
106 Valero St. Salcedo Village, P.O. Box 2108 MCC, MAKATI,
Metro MANILA, Tel. +63 2 816 6380, Fax. +63 2 817 3474

Poland: Ul. Lukiska 10, PL 04-123 WARSZAWA,
Tel. +48 22 612 2831, Fax. +48 22 612 2327

Portugal: see Spain

Romania: see Italy

Russia: Philips Russia, Ul. Usatcheva 35A, 119048 MOSCOW,
Tel. +7 095 755 6918, Fax. +7 095 755 6919

Singapore: Lorong 1, Toa Payoh, SINGAPORE 319762,
Tel. +65 350 2538, Fax. +65 251 6500

Slovakia: see Austria

Slovenia: see Italy

South Africa: S.A. PHILIPS Pty Ltd., 195-215 Main Road Martindale,
2092 JOHANNESBURG, P.O. Box 7430 Johannesburg 2000,
Tel. +27 11 470 5911, Fax. +27 11 470 5494

South America: Al. Vicente Pinzon, 173, 6th floor,
04547-130 SÃO PAULO, SP, Brazil,
Tel. +55 11 821 2333, Fax. +55 11 821 2382

Spain: Balmes 22, 08007 BARCELONA,
Tel. +34 93 301 6312, Fax. +34 93 301 4107

Sweden: Kottbygatan 7, Akalla, S-16485 STOCKHOLM,
Tel. +46 8 5985 2000, Fax. +46 8 5985 2745

Switzerland: Allmendstrasse 140, CH-8027 ZÜRICH,
Tel. +41 1 488 2741 Fax. +41 1 488 3263

Taiwan: Philips Semiconductors, 6F, No. 96, Chien Kuo N. Rd., Sec. 1,
TAIPEI, Taiwan Tel. +886 2 2134 2865, Fax. +886 2 2134 2874

Thailand: PHILIPS ELECTRONICS (THAILAND) Ltd.,
209/2 Sanpavuth-Bangna Road Prakanong, BANGKOK 10260,
Tel. +66 2 745 4090, Fax. +66 2 398 0793

Turkey: Talatpasa Cad. No. 5, 80640 GÜLTEPE/ISTANBUL,
Tel. +90 212 279 2770, Fax. +90 212 282 6707

Ukraine: PHILIPS UKRAINE, 4 Patrice Lumumba str., Building B, Floor 7,
252042 KIEV, Tel. +380 44 264 2776, Fax. +380 44 268 0461

United Kingdom: Philips Semiconductors Ltd., 276 Bath Road, Hayes,
MIDDLESEX UB3 5BX, Tel. +44 181 730 5000, Fax. +44 181 754 8421

United States: 811 East Arques Avenue, SUNNYVALE, CA 94088-3409,
Tel. +1 800 234 7381

Uruguay: see South America

Vietnam: see Singapore

Yugoslavia: PHILIPS, Trg N. Pasica 5/v, 11000 BEOGRAD,
Tel. +381 11 625 344, Fax. +381 11 635 777

For all other countries apply to: Philips Semiconductors,
International Marketing & Sales Communications, Building BE-p, P.O. Box 218,
5600 MD EINDHOVEN, The Netherlands, Fax. +31 40 27 24825

Internet: <http://www.semiconductors.philips.com>

© Philips Electronics N.V. 1998

SCA60

All rights are reserved. Reproduction in whole or in part is prohibited without the prior written consent of the copyright owner.

The information presented in this document does not form part of any quotation or contract, is believed to be accurate and reliable and may be changed without notice. No liability will be accepted by the publisher for any consequence of its use. Publication thereof does not convey nor imply any license under patent- or other industrial or intellectual property rights.

Printed in The Netherlands

545102/00/01/pp16

Date of release: 1998 Oct 30

Document order number: 9397 750 04251

Let's make things better.

Philips
Semiconductors



PHILIPS