

Applications

- IEEE 802.11b DSSS radios, Wireless LAN
- 2.4GHz cordless phones, ISM radios

Features

- Integrated power detector circuit
- High linear output power for IEEE802.11b: +20dBm, ACPR 1st lobe -30dBc, 2nd lobe -50dBc
- Low current consumption: 110mA at 3.3V
- High saturated output power for cordless telephone applications: +23dBm, 140mA at 3.6V
- Single supply voltage: 2.7 to 3.6V
- Wide Temperature range: -40°C to +85°C
- Integrated linear analog control for DC current and output power management
- Small plastic package: 8 Pin LPCC

Ordering Information

Type	Package	Remark
SE2522L	8 Pin LPCC	Samples
SE2522L-R	8 Pin LPCC	Shipped in Tape & Reel
SE2522L-EK1	Evaluation Kit	

Product Description

The SE2522L is a power amplifier IC designed for the 2.4GHz ISM band and compliant with the IEEE 802.11b WLAN standard. It typically provides +20dBm linear output power requiring only 110mA at 3.3V. It can also be utilized in 2.4GHz cordless telephone applications where it typically provides +23dBm saturated output power at 3.6V.

The SE2522L includes an integrated power detector circuit for closed loop monitoring of output power. It has an input power range of 15dB with an accuracy of ±1.0dB. An accurate automatic level control function can easily be implemented using this power detector circuit.

The SE2522L contains a linear analog control (0.1 to 1.6V) for minimizing DC current consumption and maximizing PAE.

The SE2522L includes a digital enable control for device on/off control where ramping is typically 1 µsec.

This device is capable of operating at a duty cycle of 100 percent.

Functional Block Diagram

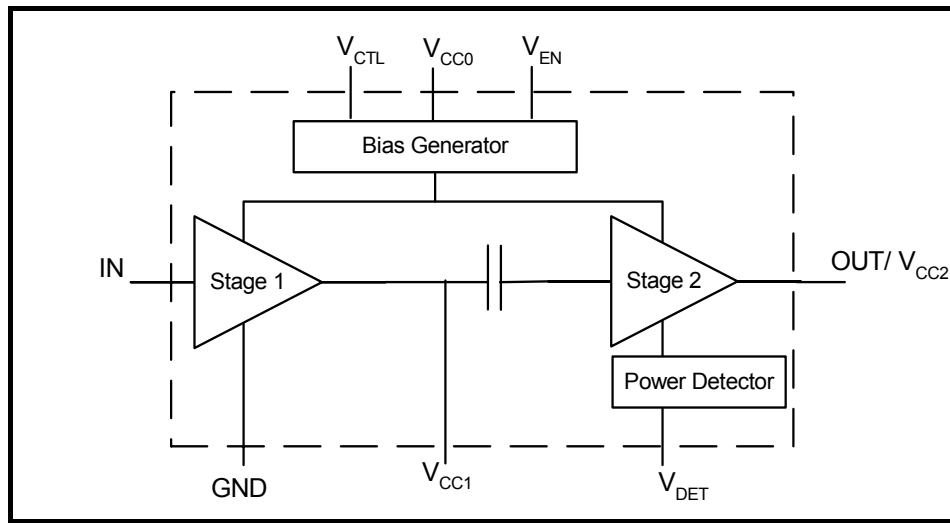

Pin Out Diagram

Note: Pads and die pad shown are at the bottom of package.

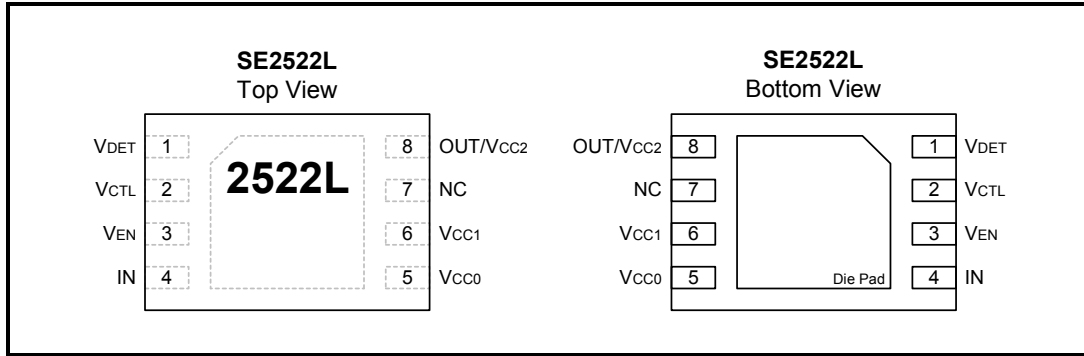

Pin Out Description

Pin No.	Name	Description
1	V _{DET}	Analog power detector output
2	V _{CTL}	Controls the RF output power and DC current level of the power amplifier. An analog control signal between 0.1V and 1.6V varies the PA output power between Min. and Max. values.
3	V _{EN}	Power Amplifier Enable pin. A digital control signal with logic high (power up) and logic low (power down) is used to turn the device on and off.
4	IN	Power amplifier RF input, external input matching network with DC blocking is required.
5	V _{CC0}	Bias supply voltage.
6	V _{CC1}	Stage 1 collector supply voltage, an external inter-stage matching network is required.
7	NC	No connect
8	OUT/V _{CC2}	PA Output and Stage2 collector supply voltage, external output matching network with DC blocking is required.
Die Pad	GND	Heatslug Die Pad is ground

Absolute Maximum Ratings

These are stress ratings only. Exposure to stresses beyond these maximum ratings may cause permanent damage to, or affect the reliability of the device. Avoid operating the device outside the recommended operating conditions defined below. This device is ESD sensitive with an ESD rating of < 600V. Handling and assembly of this device should be at ESD protected workstations.

Symbol	Parameter	Min.	Max.	Unit
V _{CC}	Supply Voltage	-0.3	+3.6	V
V _{CTL}	Control Voltage	-0.3	V _{CC}	V
V _{EN}	Ramping Voltage	-0.3	V _{CC}	V
P _{IN}	RF Input Power		+8	dBm
T _{STG}	Storage Temperature Range	-40	+150	°C
T _j	Maximum Junction Temperature		+150	°C

Recommended Operating Conditions

Symbol	Parameter	Min.	Typ.	Max.	Unit
T _A	Operating Temperature	-40		+85	°C
V _{CC}	Supply Voltage	2.7	3.3	3.6	V

DC Electrical Characteristics

Conditions: V_{CC0}=V_{CC1}=V_{CC2}=V_{EN}=3.3V, V_{CTL}=1.6V, T_A=25°C, f=2.45GHz, using IEEE802.11b modulation, Input and Output externally matched to 50Ω, unless otherwise noted.

Symbol	Parameter	Min.	Typ.	Max.	Unit
I _{CC}	Supply Current, V _{CTL} = 1.6V, P _{IN} = -7dBm	-	110	130	mA
I _{CC(sat)}	Supply Current (sat) @ P _{IN} = +2dBm	-	140	175	mA
V _{CTL}	PA Output Power Control Voltage Range	0.1		1.6	V
I _{CTL}	Current sunk by V _{CTL} Pin		55	100	μA
V _{EN}	Logic High Voltage	2.0			V
	Logic Low Voltage			0.8	V
I _{STBY}	Leakage Current when V _{EN} = 0V, V _{CTL} = 0V		0.1	200	μA

AC Electrical Characteristics

Conditions: $V_{CC0} = V_{CC1} = V_{CC2} = V_{EN} = 3.3V$, $V_{CTL} = 1.6V$, $T_A = 25^\circ C$, $f = 2.45GHz$, using IEEE802.11b modulation, and SiGe Semiconductor SE2522L-EK1 Evaluation Kit otherwise noted.

Symbol	Parameter	Note	Min.	Typ.	Max.	Unit
f_{L-U}	Frequency Range		2400		2485	MHz
P_{OUT}	Output Power @ $P_{IN} = -7dBm$, $V_{CTL} = 1.6V$, ACPR < -30dBc	2	18	20	22	dBm
	Output Power @ $P_{IN} = -7dBm$, $V_{CTL} = 0.1V$, ACPR < -30dBc	2	-	-5	5	dBm
	Output Power (sat) @ $P_{IN} = +2dBm$, $V_{CTL} = 1.6V$	3	21	23	-	dBm
dP_{OUT}/dV_{CTL}	Control Voltage Sensitivity			20		dB/V
G	Gain, small signal			27		dB
G_{VAR}	Gain Variation over band (2400-2485MHz)			1.0	2.0	dB
2f,3f,4f,5f	Harmonics	1			-50	dBc
$IS_{21} I_{OFF}$	Isolation in "OFF" State, $P_{IN} \leq +2dBm$, $V_{EN} = 0V$		20	30		dB
$IS_{12} $	Reverse Isolation		32	42		dB
t_R	Rise and Fall Time 10% to 90%			1.2		μs
STAB	Stability ($P_{IN} \leq +2dBm$, Load VSWR = 6:1)		All non-harmonically related outputs less than -50 dBc/100kHz			
PDR	Power detect range, peak power		6		23	dBm
PDT	PA power detect, response time, 5pF load	4		0.1	5	μsec
PDV_{max}	PA power detect, output voltage maximum, load > 5kOhms	4			1.8	V
PDV_{min}	PA power detect, output voltage minimum, load > 5kOhms	4		0.2		V
PDV_{p19}	PA power detect output voltage, $P_{OUT} = 13dBm$ peak	4		0.8		V
PDV_{a19}	PA power detect output voltage accuracy, $P_{OUT} = 19dBm$ peak	4		± 35		mV

- Notes:** (1) Harmonic levels and ACPR are greatly affected by topology of external matching networks.
(2) Parameter measured with RF modulation based on IEEE 802.11b standard and matching networks optimized for linear output power performance
(3) With matching networks optimized for saturated output power performance
(4) Measured at V_{DET} pin

Typical Performance Characteristics

Conditions: $V_{CC}=3.3V$, $V_{CTL}=1.6V$, $V_{EN}=3.3V$, $F=2.45GHz$, using IEEE802.11b modulation, and matching networks optimized for linear output power performance. Performance graphs are based on preliminary evaluation information and may differ from the AC and DC electrical specifications.

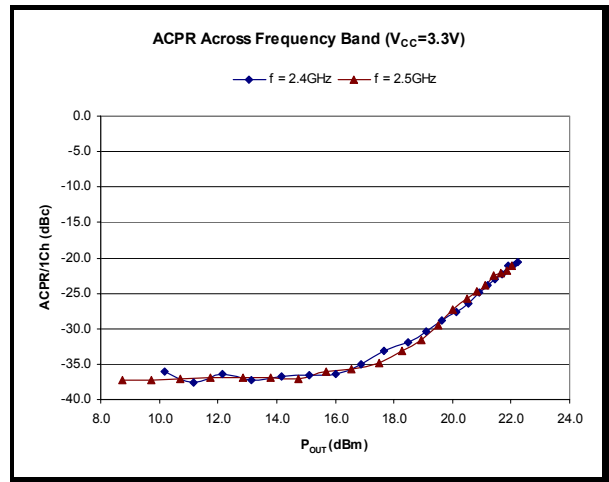
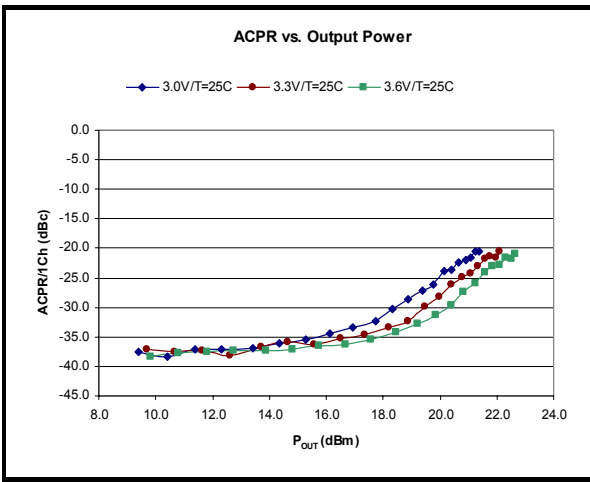
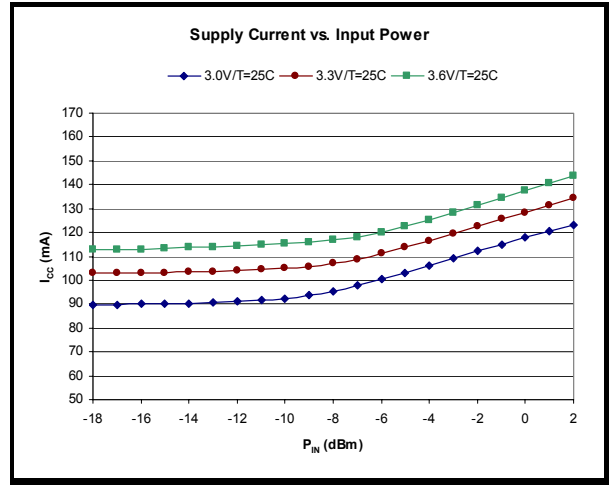
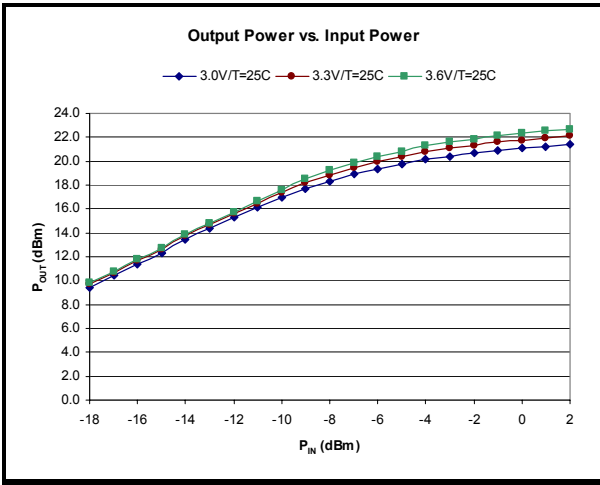

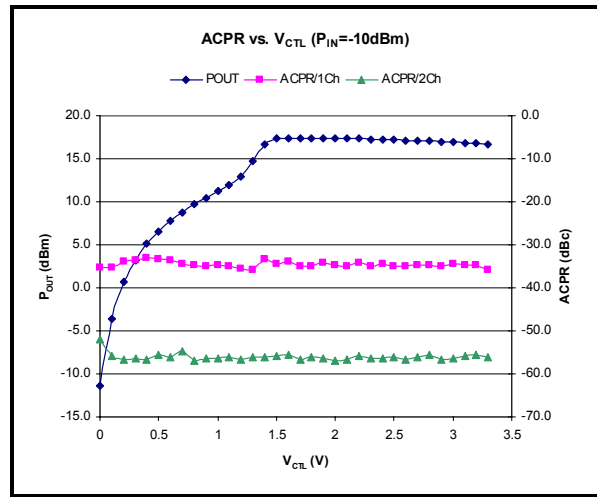
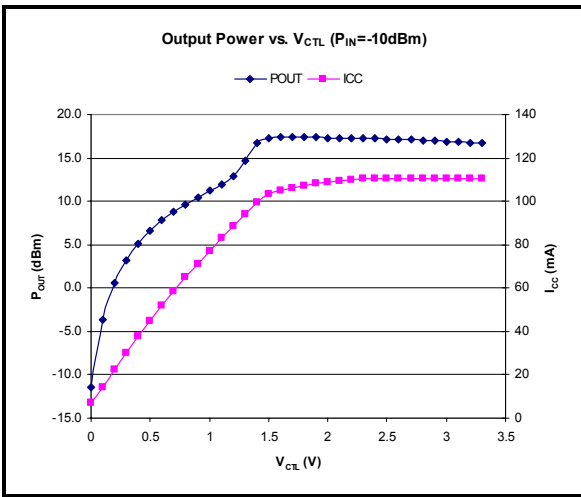
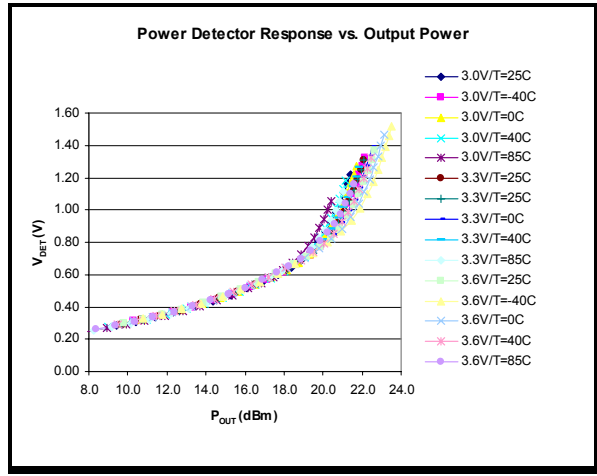
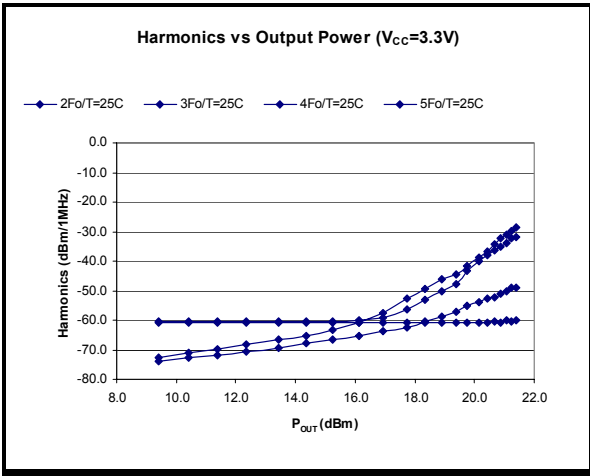

Package Information

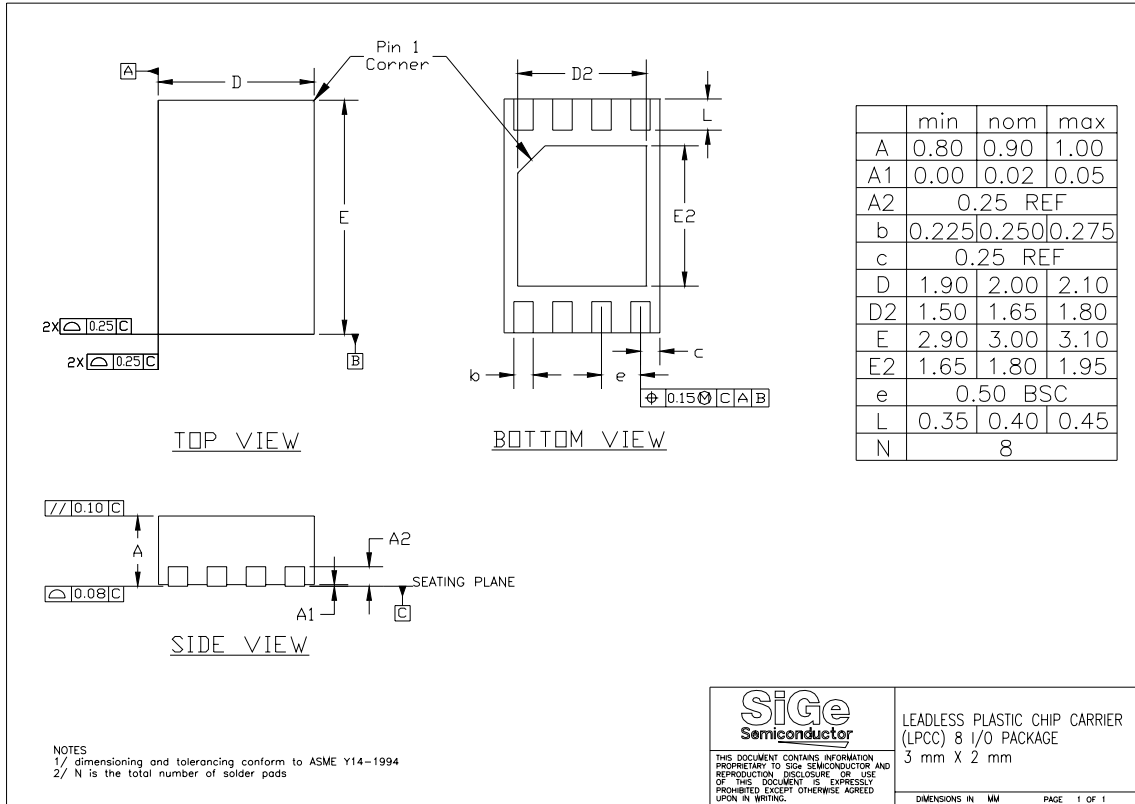

- Notes:**
1. Dimensions are in millimeters
 2. Tolerance 0.1mm unless otherwise specified
 3. Moisture/Reflow Sensitivity Classification: Level 1 (IPC/JEDEC-J-STD-020A)
 4. Lead finish is 100% lead free electrolytic tin.
 5. Exposed heat/electrical ground pad at bottom of package

<http://www.sige.com>

Headquarters: Canada

Phone: +1 613 820 9244

Fax: +1 613 820 4933

2680 Queensview Drive

Ottawa ON K2B 8J9 Canada

sales@sige.com

San Diego

Phone: +1 858 668 3541

Fax: +1 858 668 3546

Hong Kong

Phone: +1 852 9177 1917

United Kingdom

South Building, Walden Court
Parsonage Lane, Bishop's Stortford
Hertfordshire CM23 5DB

Phone: +44 1279 464 200

Fax: +44 1279 464 201

Product Preview

The datasheet contains information from the product concept specification. SiGe Semiconductor Inc. reserves the right to change information at any time without notification.

Preliminary Information

The datasheet contains information from the design target specification. SiGe Semiconductor Inc. reserves the right to change information at any time without notification.

Final

The datasheet contains information from the final product specification. SiGe Semiconductor Inc. reserves the right to change information at any time without notification. Production testing may not include testing of all parameters.

Information furnished is believed to be accurate and reliable and is provided on an "as is" basis. SiGe Semiconductor Inc. assumes no responsibility or liability for the direct or indirect consequences of use of such information nor for any infringement of patents or other rights of third parties, which may result from its use. No license or indemnity is granted by implication or otherwise under any patent or other intellectual property rights of SiGe Semiconductor Inc. or third parties. Specifications mentioned in this publication are subject to change without notice. This publication supersedes and replaces all information previously supplied. SiGe Semiconductor Inc. products are NOT authorized for use in implantation or life support applications or systems without express written approval from SiGe Semiconductor Inc.

RangeCharger™, StreamCharger™, PointCharger™, and LightCharger™ are trademarks owned by SiGe Semiconductor Inc.

Copyright 2002 SiGe Semiconductor
All Rights Reserved