

---

# MSM9006-01, -02

---

## LCD Driver with Keyscan Function

---

### GENERAL DESCRIPTION

The MSM9006-01 is an LCD driver for a 1/3 duty dynamic display. It can directly drive an LCD with a maximum of 123 segments.

The MSM9006-02 is an LCD driver for a 1/4 duty dynamic display, and can directly drive an LCD with a maximum of 164 segments.

The MSM9006-01, -02 are capable of directly driving one LED, and up to five ports can be used by simply switching the LCD pin.

The internal 5 x 5 keyscan circuit enables keyboard input, decreasing the number of interconnections between the front panel and the CPU.

### FEATURES

- 41 segment outputs (when LED and output port are not used)
  - A maximum of 123 segments can be displayed (MSM9006-01)
  - A maximum of 164 segments can be displayed (MSM9006-02)
- One LED can be driven directly ( $I_O = -15\text{mA}$  max.)
- Up to five output ports are available ( $I_O = -2\text{mA}$  to  $+1\text{mA}$ )
- The state of up to 25 key switches can be read through the internal 5 x 5 keyscan circuit
- The interface with the CPU is a serial interface using LOAD, DATA I/O, and CLOCK
- Built-in RC oscillation circuit for LCD alternating current drive
- Built-in voltage dividing resistor for bias voltage generation
- Power supply voltage:  $5\text{V} \pm 10\%$
- Temperature range :  $-40$  to  $+85^\circ\text{C}$
- Package:
  - 64-pin plastic QFP (QFP64-P-1414-0.80-BK) (Product name : MSM9006-01GS-BK)
  - (Product name : MSM9006-02GS-BK)

**BLOCK DIAGRAM**

**MSM9006-01**

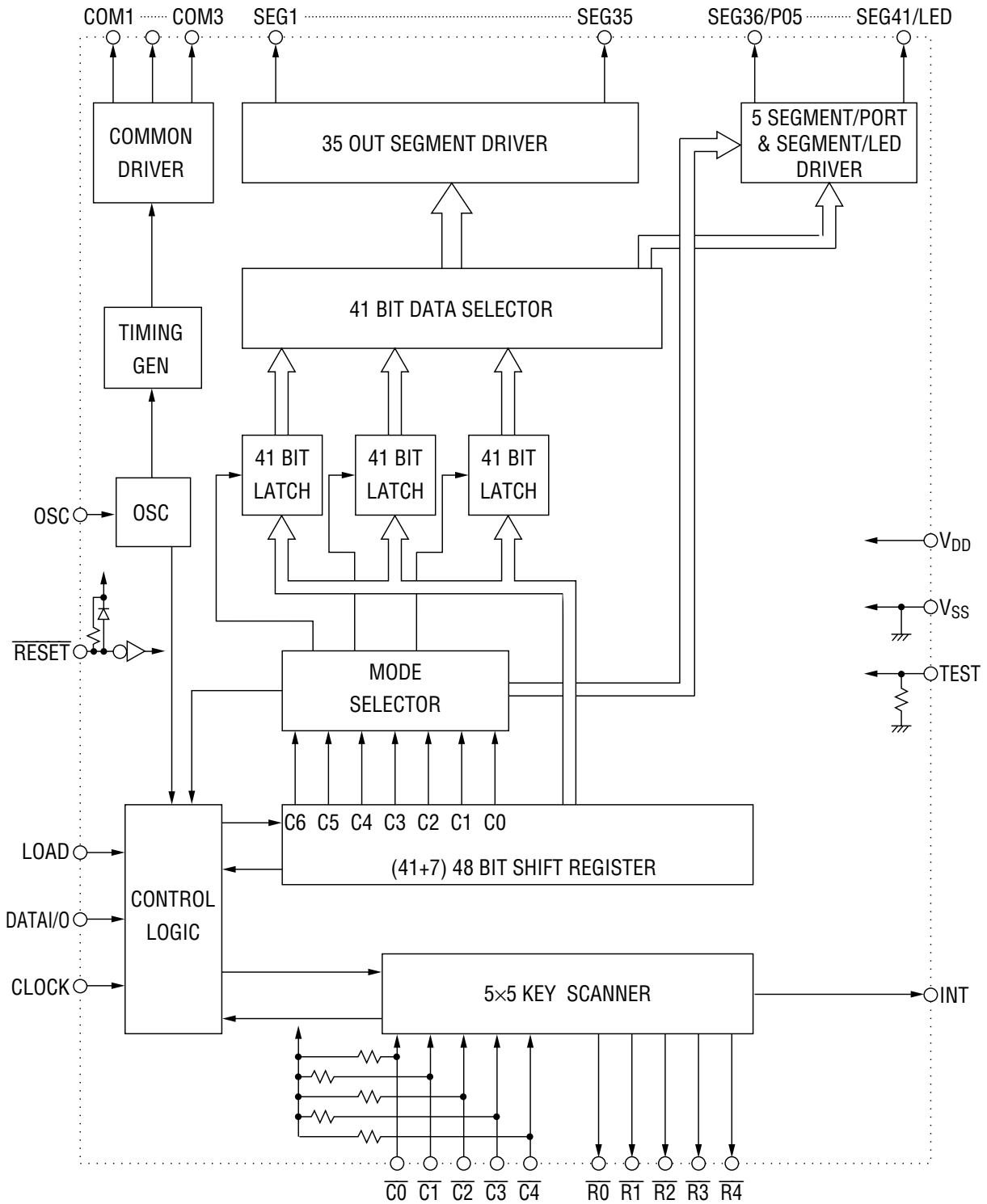

**BLOCK DIAGRAM**

**MSM9006-02**

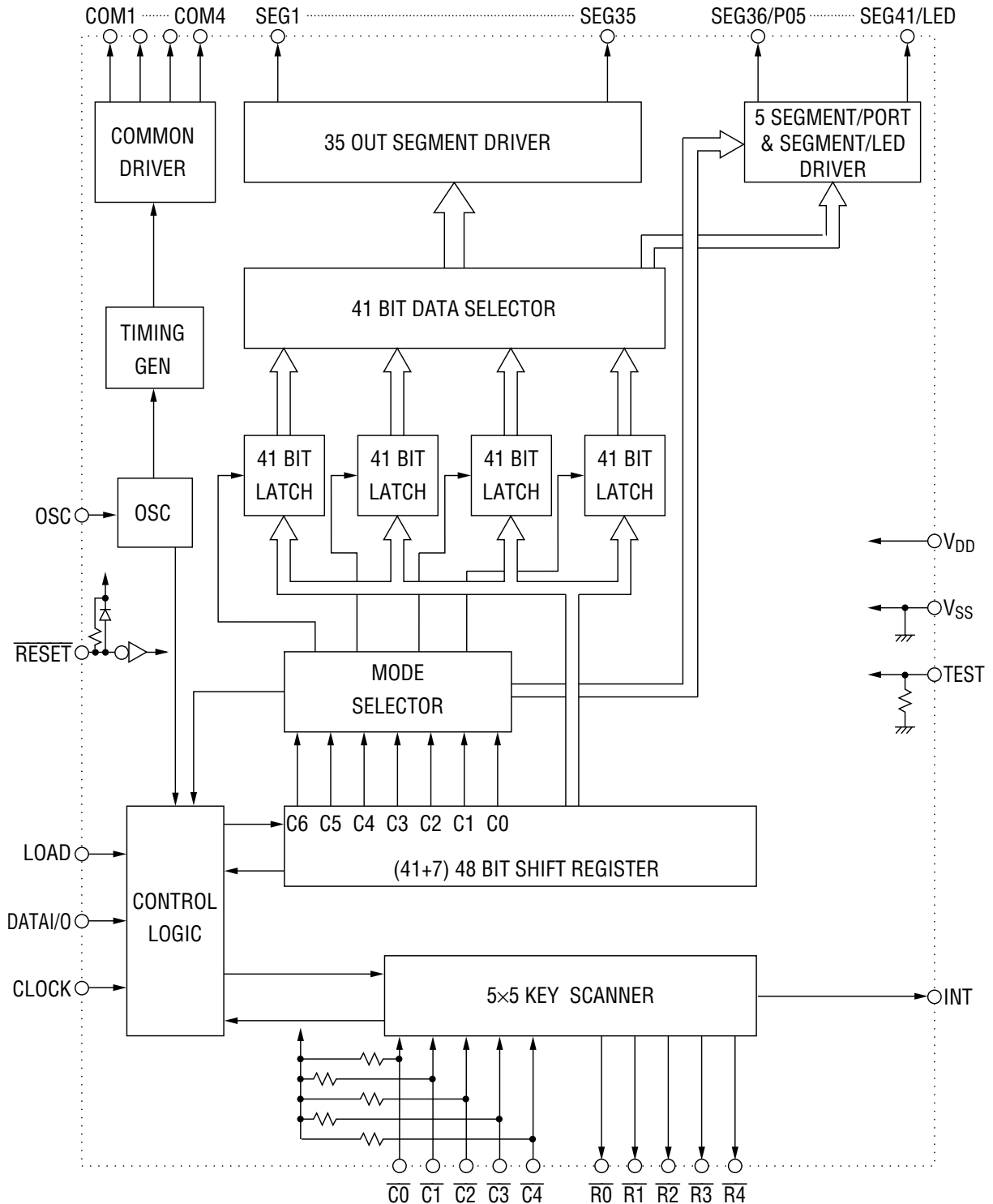

**PIN CONFIGURATION (TOP VIEW)**

**MSM9006-01**

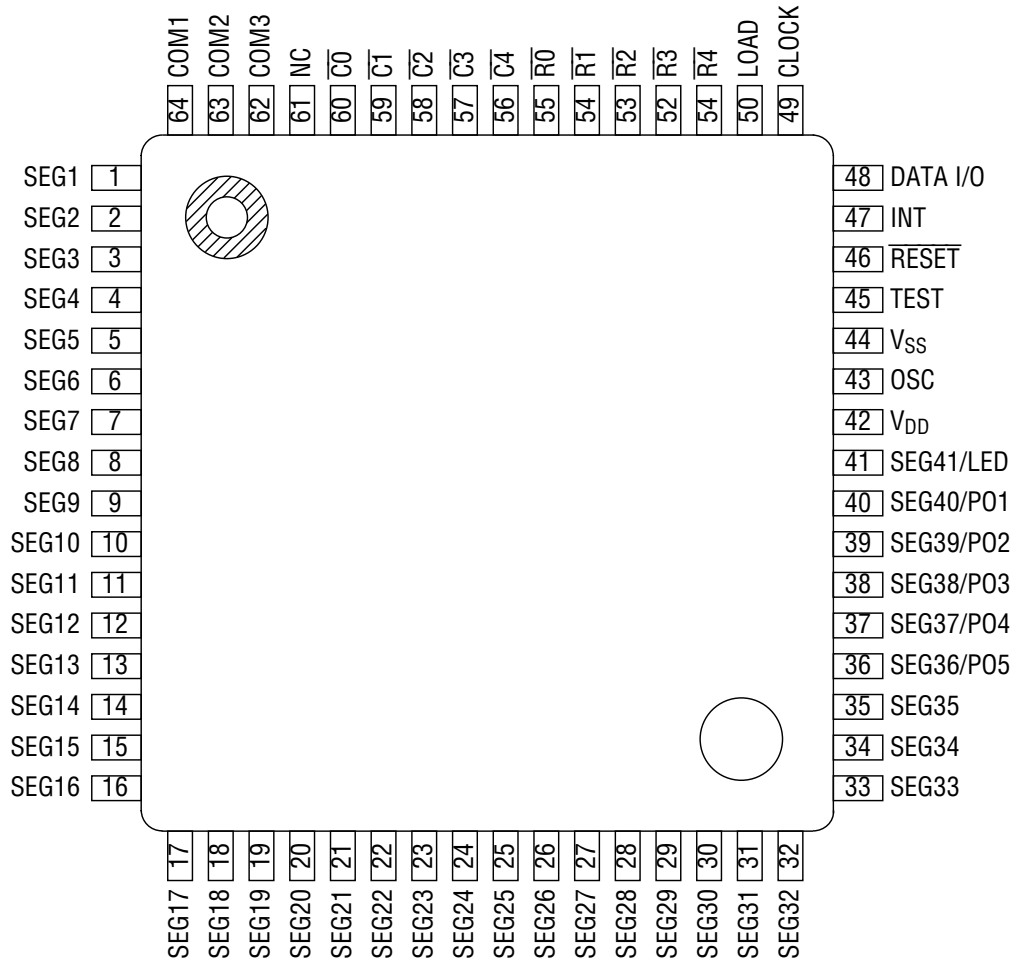

NC: No-connection pin

**64-Pin Plastic QFP**

**PIN CONFIGURATION (TOP VIEW)**

**MSM9006-02**

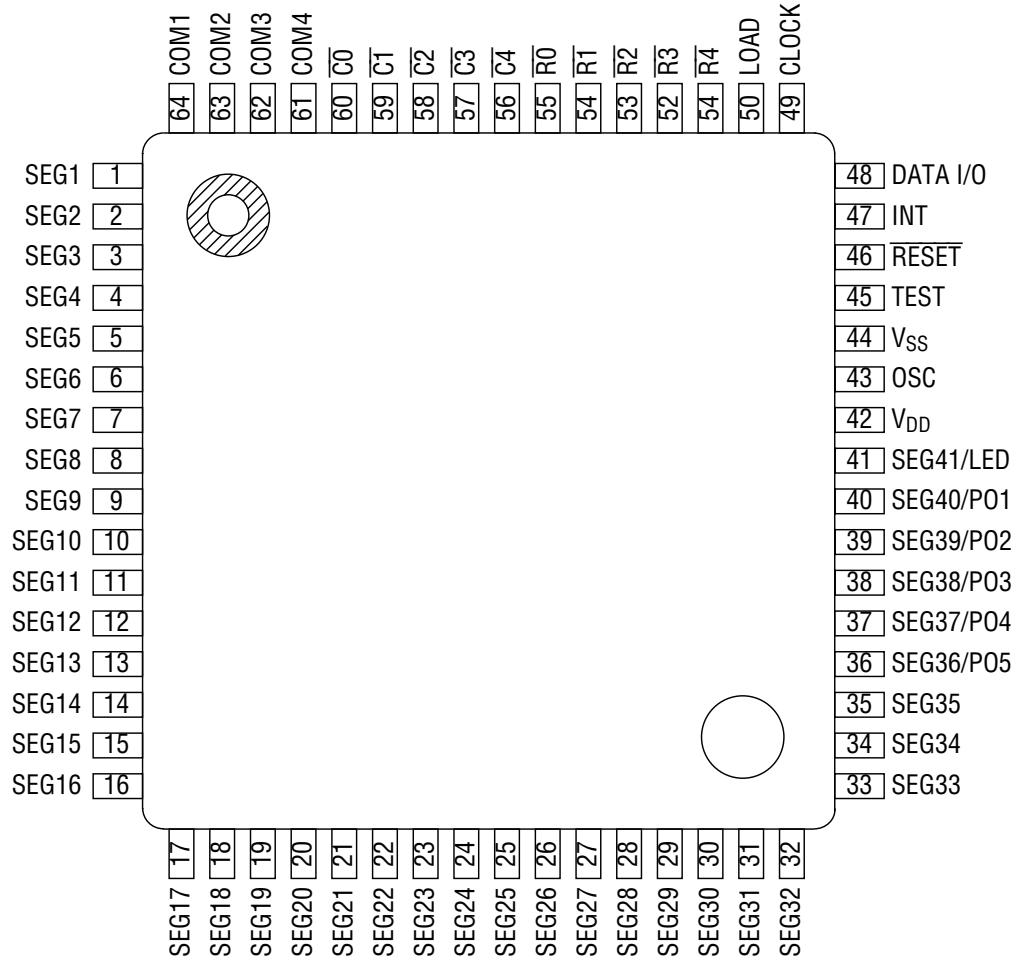

**64-Pin Plastic QFP**

**ABSOLUTE MAXIMUM RATINGS**

Paramater	Symbol	Condition	Rating	Unit
Supply Voltage	$V_{DD}$	$T_a=25^{\circ}\text{C}$	-0.3 to +6.5	V
Input Voltage	$V_I$	$T_a=25^{\circ}\text{C}$	-0.3 to $V_{DD}+0.3$	V
Output Current	$I_O$	$T_a=25^{\circ}\text{C}$ *1	-20	mA
		$T_a=25^{\circ}\text{C}$ *2	-3	mA
Storage Temperature	$T_{STG}$	—	-55 to +150	$^{\circ}\text{C}$

\*1 Applies to LED output.

\*2 Applies to port output.

**RECOMMENDED OPERATING CONDITIONS**

Paramater	Symbol	Condition	Range	Unit
Supply Voltage	$V_{DD}$	$V_{SS}=0\text{V}$	4.5 to 5.5	V
Operating Temperature	$T_{op}$	—	-40 to +85	$^{\circ}\text{C}$

**Recommended Oscillation Circuit Conditions**

Paramater	Symbol	Condition	Min.	Max.	Unit
Oscillation Resistance	$R_O$	—	20	82	$\text{k}\Omega$
Oscillation Capacitance	$C_O$	—	0.01	0.047	$\mu\text{F}$

## ELECTRICAL CHARACTERISTICS

## DC Characteristics

(V<sub>DD</sub>=5V±10%, Ta=-40 to +85°C)

Parameter	Symbol	Condition	Min.	Max.	Unit	Applicable Pin		
"H" Input Voltage	V <sub>IH1</sub>	—	0.8V <sub>DD</sub>	V <sub>DD</sub>	V	*1		
"L" Input Voltage	V <sub>IL1</sub>	—	V <sub>SS</sub>	0.2V <sub>DD</sub>	V			
"H" Input Voltage	V <sub>IH2</sub>	—	0.7V <sub>DD</sub>	V <sub>DD</sub>	V	$\overline{C0}$ to $\overline{C4}$		
"L" Input Voltage	V <sub>IL2</sub>	—	V <sub>SS</sub>	0.3V <sub>DD</sub>	V			
"H" Input Current	I <sub>IH1</sub>	V <sub>DD</sub> =5.5V	V <sub>I</sub> =V <sub>DD</sub>	—	1	CLOCK, LOAD		
"L" Input Current	I <sub>IL1</sub>		V <sub>I</sub> =0V	—	-1		μA	
"H" Input Current	I <sub>IH2</sub>		V <sub>I</sub> =V <sub>DD</sub>	—	10	DATA I/O		
"L" Input Current	I <sub>IL2</sub>		V <sub>I</sub> =0V	—	-10		μA	
"L" Input Current	I <sub>IL3</sub>	V <sub>DD</sub> =5.0V	V <sub>I</sub> =0V	-0.18	-0.9	$\overline{C0}$ to $\overline{C4}$		
"L" Input Current	I <sub>IL4</sub>		V <sub>I</sub> =0V	-0.02	-0.1	RESET		
Segment Output Voltage	V <sub>OS0</sub>	V <sub>DD</sub> =4.5V	I <sub>O</sub> =-10μA	V <sub>DD</sub> -0.7	—	SEG1 to SEG35, SEG36/PO5 to SEG41/LED *2		
	V <sub>OS1</sub>		I <sub>O</sub> =±10μA	2/3V <sub>DD</sub> -0.7	2/3V <sub>DD</sub> +0.7		V	
	V <sub>OS2</sub>		I <sub>O</sub> =±10μA	1/3V <sub>DD</sub> -0.7	1/3V <sub>DD</sub> +0.7		V	
	V <sub>OS3</sub>		I <sub>O</sub> =10μA	—	V <sub>SS</sub> +0.7		V	
Common Output Voltage	V <sub>OC0</sub>	V <sub>DD</sub> =4.5V	I <sub>O</sub> =-10μA	V <sub>DD</sub> -0.65	—	COM1 to COM4		
	V <sub>OC1</sub>		I <sub>O</sub> =±10μA	2/3V <sub>DD</sub> -0.65	2/3V <sub>DD</sub> +0.65		V	
	V <sub>OC2</sub>		I <sub>O</sub> =±10μA	1/3V <sub>DD</sub> -0.65	1/3V <sub>DD</sub> +0.65		V	
	V <sub>OC3</sub>		I <sub>O</sub> =10μA	—	V <sub>SS</sub> +0.65		V	
"H" Output Voltage	V <sub>OH1</sub>	V <sub>DD</sub> =4.5V	I <sub>O</sub> =-15mA	3.0	—	SEG41/LED		
"L" Output Voltage	V <sub>OL1</sub>		I <sub>O</sub> =0.1mA	—	0.4	V	*3	
"H" Output Voltage	V <sub>OH2</sub>		I <sub>O</sub> =-2mA	3.5	—	V	SEG36/PO5 to SEG40/PO1 *4	
"L" Output Voltage	V <sub>OL2</sub>		I <sub>O</sub> =1mA	—	1.0	V		
"H" Output Voltage	V <sub>OH3</sub>		I <sub>O</sub> =-0.4mA	4.1	—	V	DATA I/O	
"L" Output Voltage	V <sub>OL3</sub>		I <sub>O</sub> =0.4mA	—	0.4	V	INT	
"H" Output Voltage	V <sub>OH4</sub>		I <sub>O</sub> =-50μA	2.5	—	V	$\overline{R0}$ to $\overline{R4}$	
"L" Output Voltage	V <sub>OL4</sub>		I <sub>O</sub> =1.0mA	—	0.4	V	*5	
Current Consumption	I <sub>DD</sub>		V <sub>DD</sub> =5.5V	No load	—	0.45	mA	V <sub>DD</sub>

\*1 CLOCK, LOAD, DATA I/O and RESET

\*2 When SEG36/PO5-SEG41/LED are used as LCD segment output pins.

\*3 When SEG41/LED is used as output pin for LED driving.

\*4 When SEG36/PO5-SEG40/PO1 are used as general purpose port output pins.

\*5 When key data that corresponds to  $\overline{C0}$ - $\overline{C4}$  is on one of the lines to which the  $\overline{R0}$ - $\overline{R4}$  pins are connected, the key data is not identified if the line is at a "H" level.Therefore, as long as the value of V<sub>OH4</sub> is 2.5V or greater, key data is identified correctly.

Switching Characteristics

( $V_{DD}=5V\pm 10\%$ ,  $T_a=-40$  to  $+85^\circ C$ )

Paramater	Symbol	Condition	Min.	Max.	Unit
Clock Frequency	$f_{CP}$	—	—	2.0	MHz
Clock Pulse Width	$t_{WCP}$	—	200	—	ns
Rise/Fall Time	$t_r, t_f$	—	—	50	ns
Data Setup Time	$t_{DSU}$	—	100	—	ns
Data Hold Time	$t_{DHD}$	—	100	—	ns
Load Pulse Width	$t_{WLD}$	—	200	—	ns
Clock→Load Time	$t_{CL}$	—	100	—	ns
Load→Clock Time	$t_{LC}$	—	200	—	ns
Output Delay Time 1	$t_{pd1}$	$C_L=50pF$	—	300	ns
Output Delay Time 2	$t_{pd2}^{*1}$	—	—	300	ns

\*1 Since the DATA I/O pin input-output state is undefined for 300ns after the rising edge of LOAD when changing from output mode to input mode, do not input any signal to the DATA I/O pin for this period.

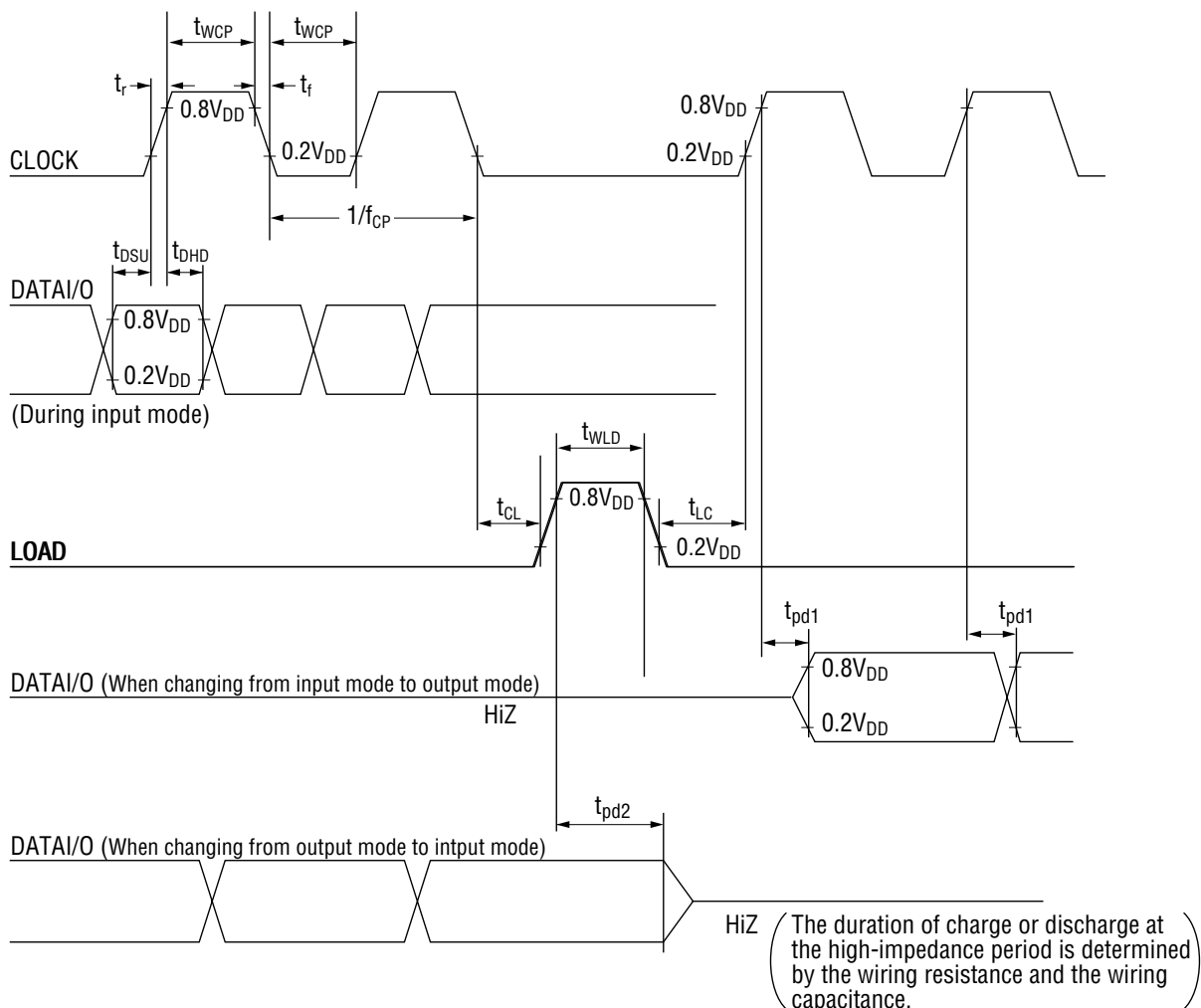



## FUNCTIONAL DESCRIPTION

### Pin Functional Description

#### • OSC

This is an input pin for the oscillator to generate LCD AC lighting and keyscan signals. Connect external capacitor and resistor as shown below to form RC oscillation circuit.

The relationship between frame frequency  $f_{FRM}$ , keyscan period  $T_{SCN}$ , and oscillation frequency  $f_{OSC}$  is:

$$f_{FRM} = f_{OSC}/24, T_{SCN} = 20/f_{OSC}$$

(See REFERENCE DATA for information on the relationship between  $C_O$ ,  $R_O$  values, frame frequency, and keyscan periods.)

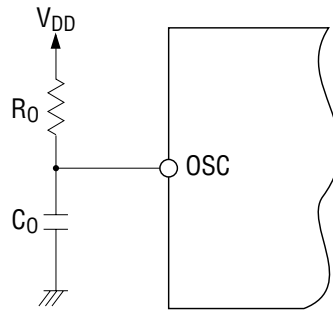

#### • DATA I/O

This is a serial data input/output. The pin is in output state for the duration from the first shift clock rising after "Key Data Output" command is entered, to the load signal rising, and in input state otherwise. (The pin is in input state after reset.)

The relationship between data level and operation is shown below.

Data Level	LCD and LED Display	Port	Key Status
"H"	ON	"H"	ON
"L"	OFF	"L"	OFF

#### • CLOCK

This is an input pin for the shift clock. DATA I/O pin data is either input or output in synchronization with the rising of the clock.

#### • LOAD

This is a load signal input pin. It is used for transferring serial input data to a latch for display, entering commands, or resetting the output state of the DATA I/O pin.

- $\overline{R0} - \overline{R4}$

These are keyswitch scan signal output pins. During the scan operation, "L" level is output in the order of  $\overline{R0}$ ,  $\overline{R1}$ , ...,  $\overline{R4}$ . All signals go to "L" level when scanning stops. (See keyscan)

- $\overline{C0} - \overline{C4}$

These are input pins that detect the key status. Pull-up resistor is included. Key matrices are formed with  $\overline{R0} - \overline{R4}$  pins.

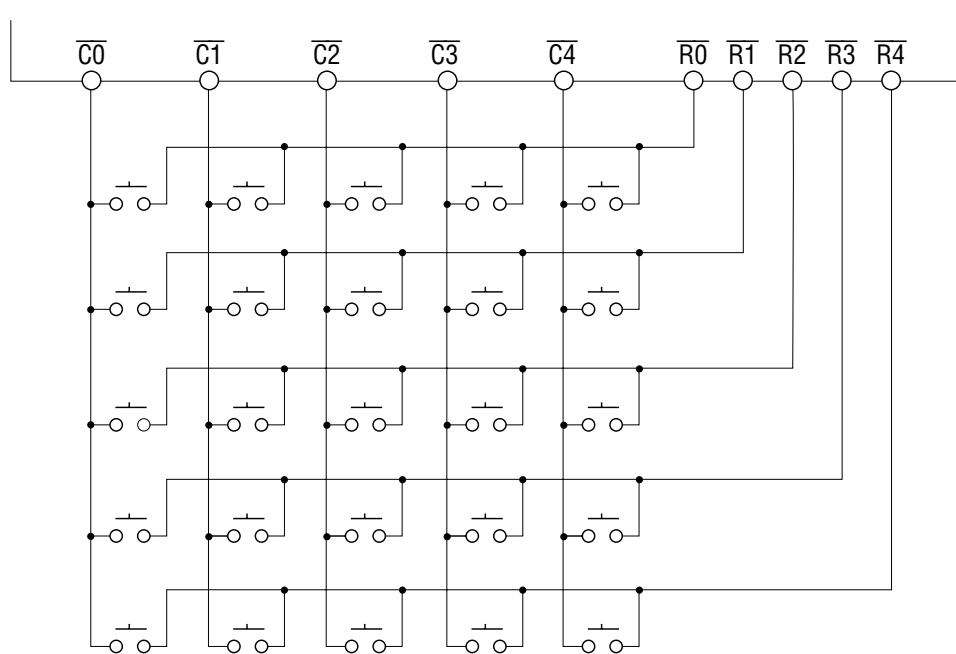

- INT

This is the keyscan end signal output pin. This pin goes to "H" level when one scan cycle ends, and returns to "L" level by a load signal after data is output or after the "Keyscan Stop" command is entered. (This pin also returns to "L" level at reset.)

- **RESET**

This is the reset signal input pin that initializes the device, and it is activated at "L" level. Pull-up resistor is included. The power-on reset operation is performed by externally connecting a capacitor. (See "Power-on Reset" in REFERENCE DATA)

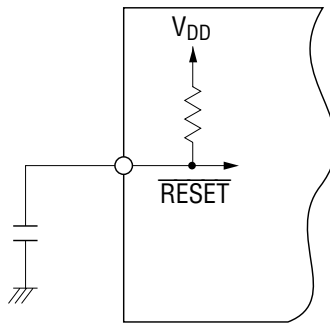

- **SEG1 - SEG35**

These are output pins for the LCD display, and are connected to the segment pins of the LCD panel. See the section on data configuration for the correspondence between SEG output and input data.

- **COM1 - COM4**

These are output pins for the LCD display, and are connected to the common pins of the LCD panel.

In the case of MSM9006-01, the COM1 to COM3 pins apply.

- **SEG36/PO5 - SEG40/PO1**

These pins can select the output pins for the LCD display (segment pins) or general port output pins by setting with commands.

- **SEG 41/LED**

This is an output pin for the LCD display (segment), or LED drive selection with command. If LED drive is selected, the LED and current limit resistor are externally connected.

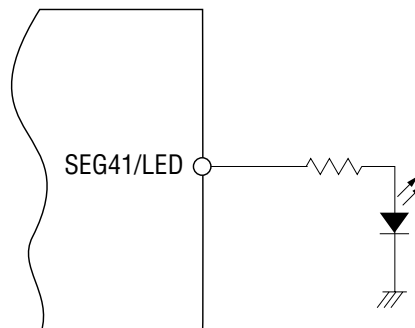

- **TEST**

This is an input pin for IC testing. This pin should be connected to  $V_{SS}$ .

- **$V_{DD}$ ,  $V_{SS}$**

These are power supply and ground pins.

### Display Data Input

As shown in the section on data configuration, the data for display consists of data field corresponding to segments ON/OFF and of command field indicating display data input.

Set the C0 and C1 bits of the command field according to the COM pins corresponding to the display data. LED display data when LED display pin is selected and output port data when output port pin is selected correspond to common 1. Data input to the DATA I/O pin is captured by a shift register at the rising edge of a clock signal, then it is transferred to a data latch for display when the LOAD signal is at "H" level, and is then output through a segment driver.

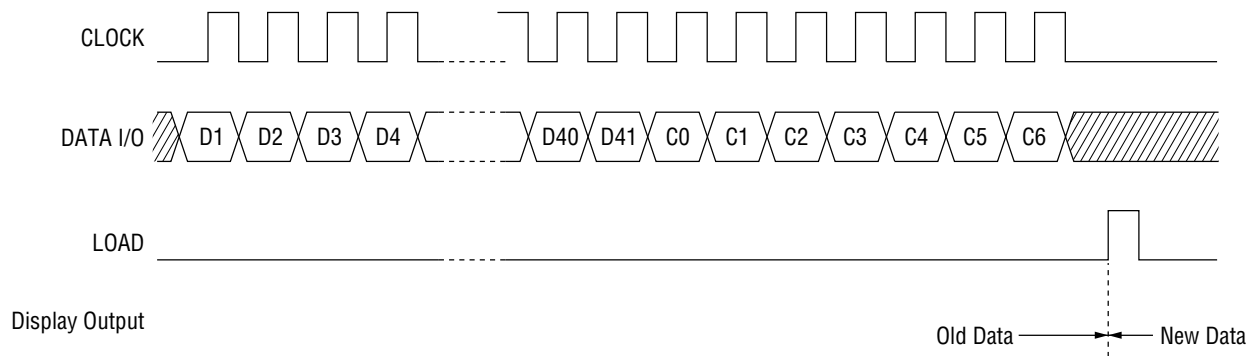

### Key Data Output

The status of a key switch is indicated by ON = 1, OFF = 0, and is read as 25-bit serial data. (For information on the sequence, see the section on data configuration.) To output data, the "Key Data Output" command is first entered. Then data is output synchronizing with the rising edge of a clock signal. If a LOAD pulse is then added, the DATA I/O pin returns to the input status, and the next data or command can be input.

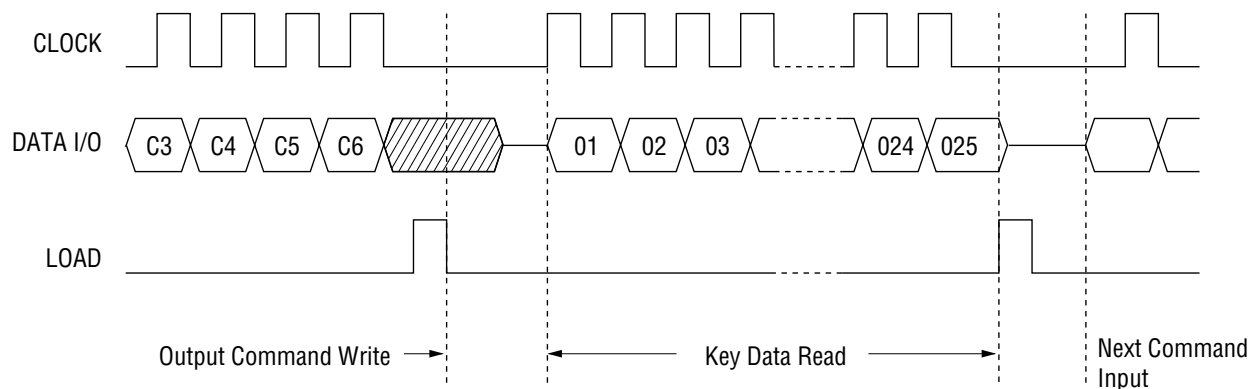

## Keyscan

Keyscan starts when the key status is changed, or when the "Keyscan Start + key data output" command is entered. Scan continues until the "Keyscan Stop" command is entered. (Scan is in stop state at power-on reset.)

When 1 keyscan cycle ends, the INT signal goes to "H" level, so this signal can be used as an interrupt flag. The INT signal is reset when the LOAD pulse is input after the key data is output, when the "Keyscan Stop" command is entered, or when a reset signal is applied.

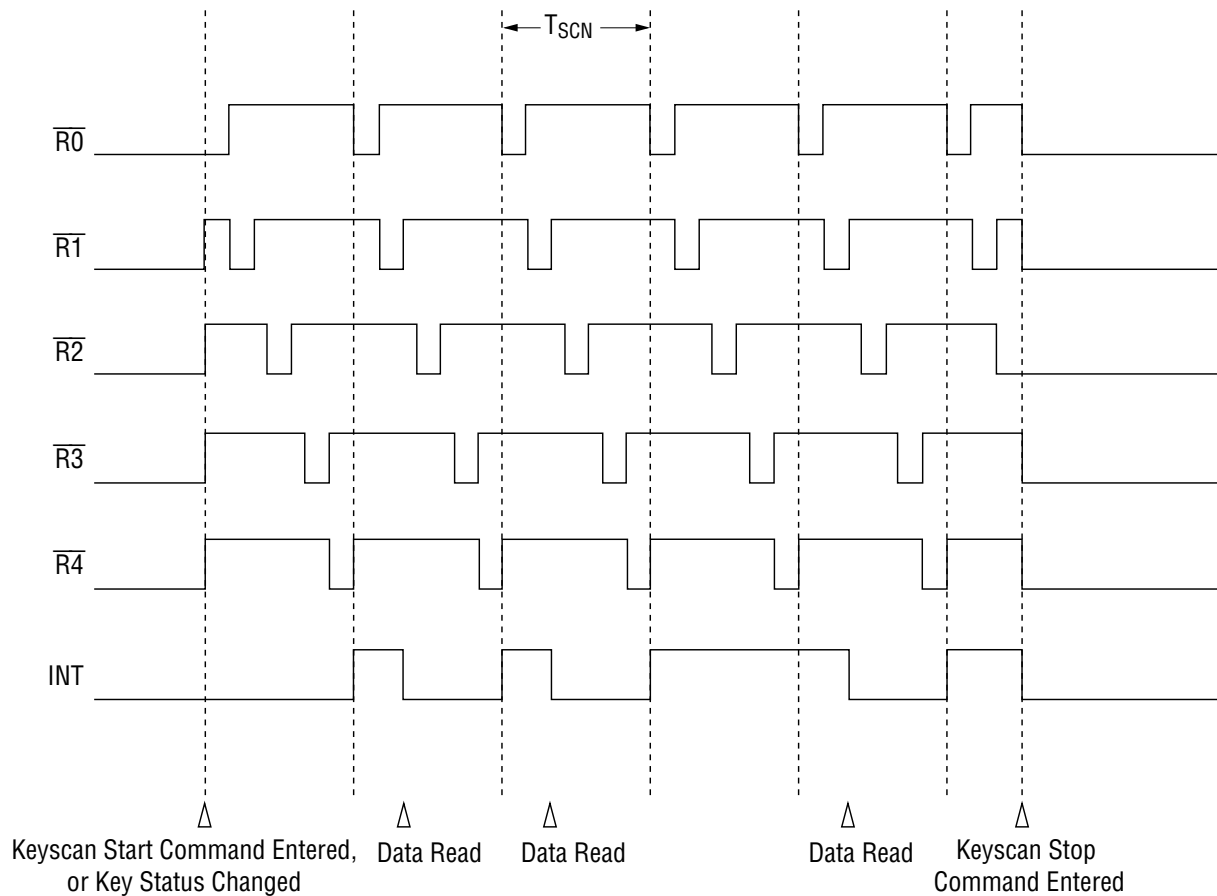

- Notes:
1. A recognition error (that is, a switch that was not pressed is recognized as being pressed) may occur when three or more key switches are pressed at the same time. If simultaneous pressing of three or more key switches must be recognized, insert diodes serially to each switch. If simultaneous pressing of three or more key switches is required not to be recognized, a possible approach is to program so that the entire key information will be ignored if there are three or more 1s in read data.
  2. A change of key status is detected as a change of column inputs ( $\overline{C0} - \overline{C4}$ ). Therefore if multiple switches which connected to the same column are pressed at the same time, it will not be detected as a change of key status.

### Display ON, Display OFF

Upon power-on reset, the display is put in off state. To turn on the display, enter the Display ON command.

Regardless of the display data, the display goes out by entering the Display OFF command because the Display OFF command turns off all segments and LED display and changes the state of the output port from "H" to "L" level.

The display returns to the initial state by entering the Display ON command because the Display ON command resets the off-state of the display.

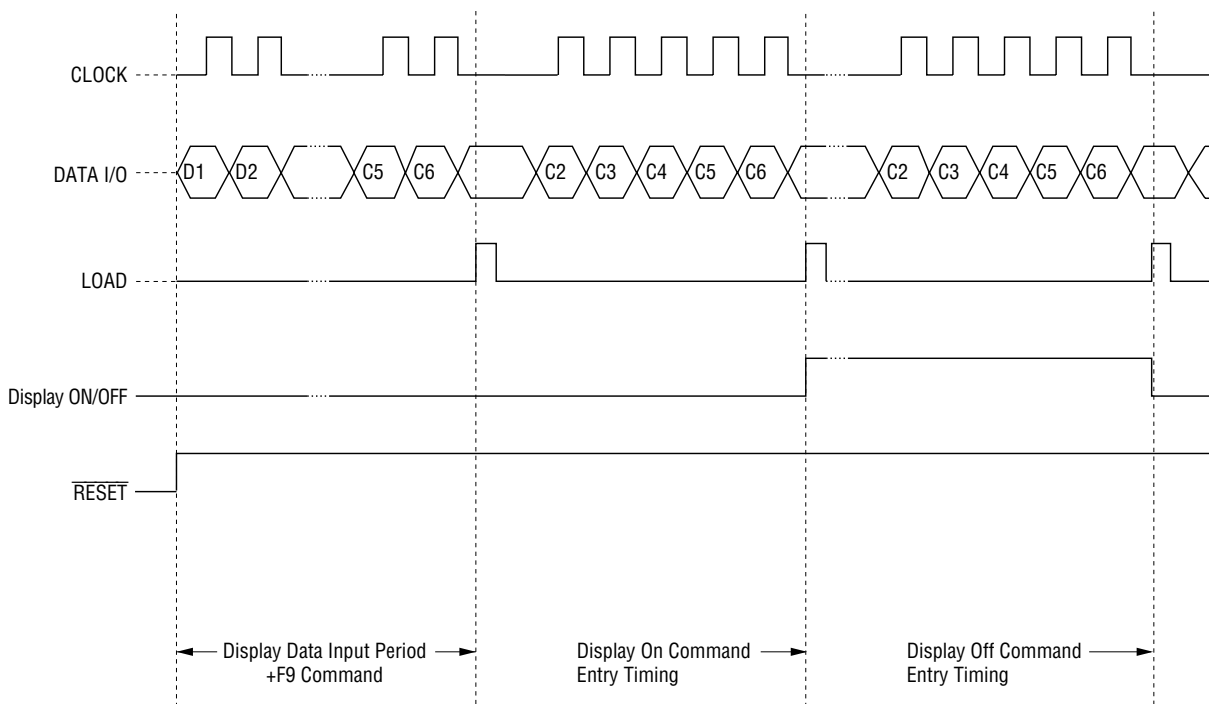

## Command List

Command	C6	C5	C4	C3	C2	C1	C0	Operation
F1	0	0	0	1	0	0	0	Display Data Input (Corresponds to common 1)
							1	Display Data Input (Corresponds to common 2)
						1	0	Display Data Input (Corresponds to common 3)
							1	Display Data Input (Corresponds to common 4) (*2)
F2	0	0	1	0	×	×	×	Key Data Output
F3	0	0	1	1	0	0	0	Display Data Input (1) + Key Data Output
							1	Display Data Input (2) + Key Data Output
						1	0	Display Data Input (3) + Key Data Output
							1	Display Data Input (4) + Key Data Output (*2)
F4	0	1	0	1	0	×	×	Display OFF
F5	0	1	0	1	1	×	×	Display ON
F6	0	1	1	0	×	×	×	Keyscan Stop + Key Data Output
F7	0	1	0	0	×	×	×	Keyscan Stop
F8	0	1	1	1	×	×	×	Keyscan Start + Key Data Output
F9	1	S/P5	S/P4	S/P3	S/P2	S/P1	S/L	LCD/Output Port, LED Pin Setting (*1)

× : Don't care

\*1 The bits C5-C0 correspond to SEG36/PO5, SEG37/PO4, SEG38/PO3, SEG39/PO2, SEG40/PO1, and SEG41/LED pin, respectively.  
The high level selects the LCD (SEG36-SEG41) output. The low level selects the output port (PO5-PO1) and LED output (any pin combination is selectable).

Because the pin select mode is not set upon power-on reset, be sure to put the device into pin select mode before entering the Display On command.

\*2 Out of the eight F1 and F3 commands, only those that correspond to common 1-3 are valid in the case of the MSM9006-01. (Common 4 is not available in the MSM9006-01.)

### Data Configuration

#### Input data

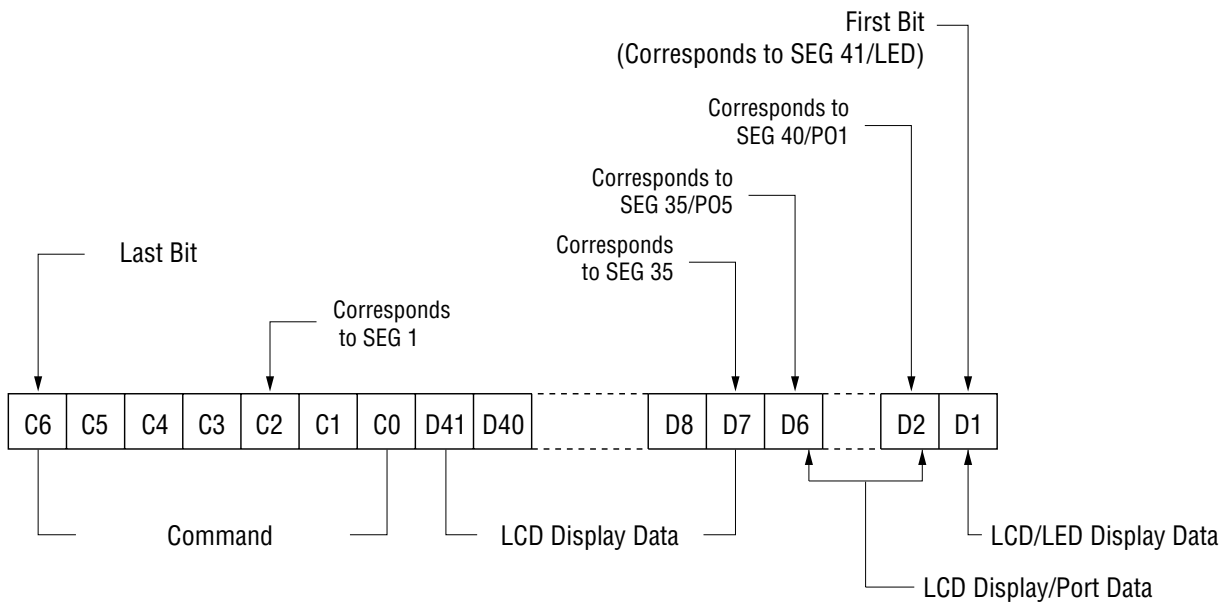

- Notes:
1. LED data when the LED pin is selected and output port data when an output port pin is selected, correspond to common 1 side (C0, C1=0).
  2. The commands F2, F6-F8 are enabled when only the 4 bits of C3-C6 are input. The commands F4 and F5 are enabled when only the 5 bits of C2-C6 are input. (Bits D1-D41, C0-C1 are not required.)
  3. If dummy bits are required depending on the number of transfer bits, insert them into the first bit side.

#### Output data

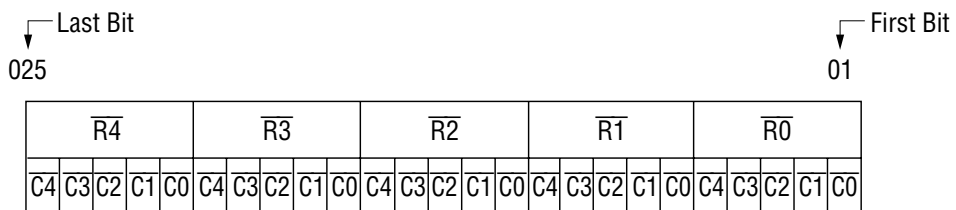



REFERENCE DATA

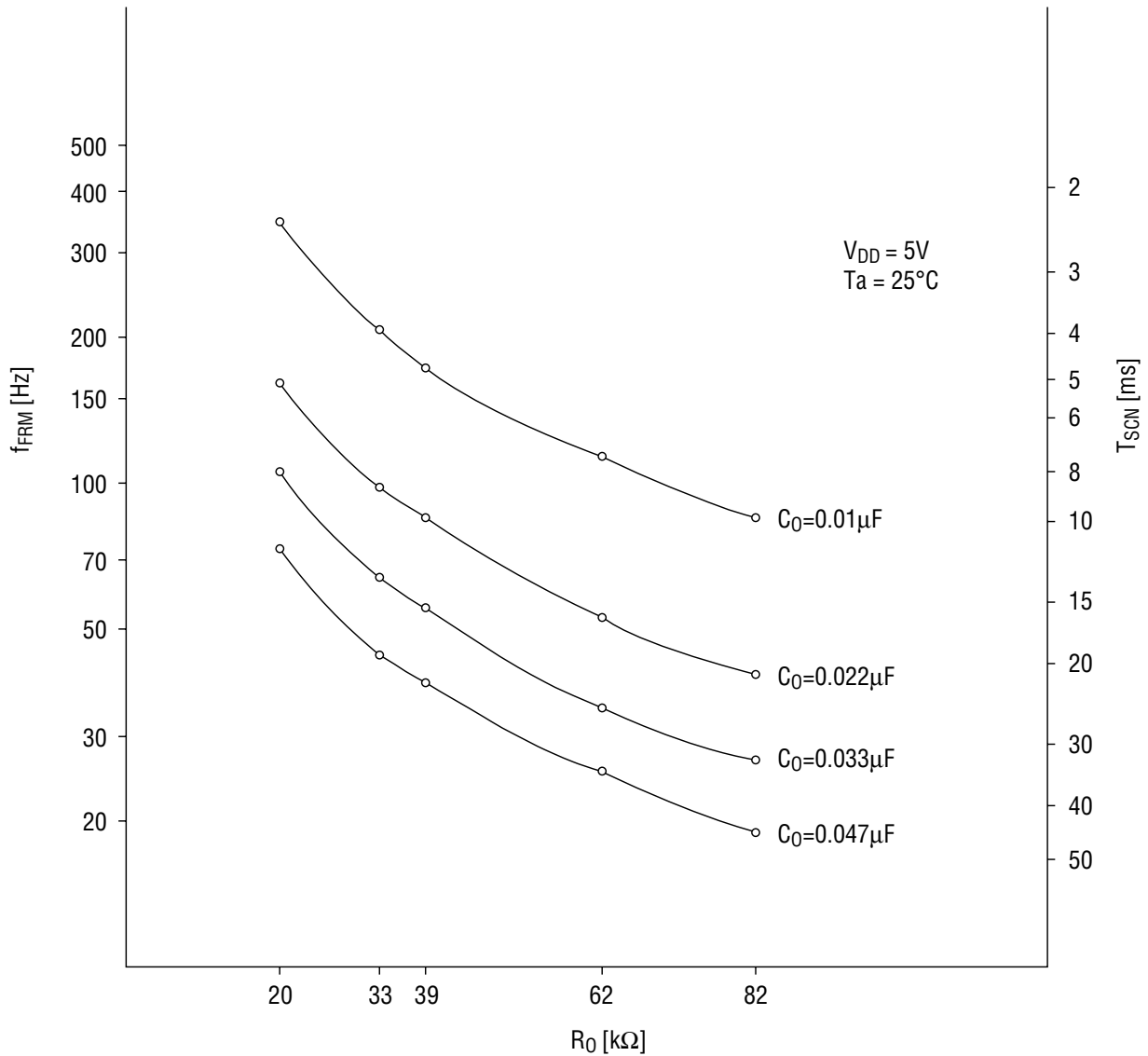

$f_{FRM}$  and  $T_{SCN}$  vs.  $R_0$  vs.  $C_0$

• Power-on Reset

The capacitance of an external capacitor connected to the  $\overline{RESET}$  pin should be:

$$C_{RST} \geq 12.5 \times T_R (\mu F)$$

(ex.  $C_{RST} \geq 0.125 (\mu F)$  if  $T_R = 10 (ms)$ )

When  $T_R$  is the rise time for power supply connected to the MSM9006 and  $C_{RST}$  is the capacitance of a capacitor connected to the  $\overline{RESET}$  pin.

The pulse width of an external reset signal should be more than  $T_R$ .

PACKAGE DIMENSIONS

(Unit : mm)

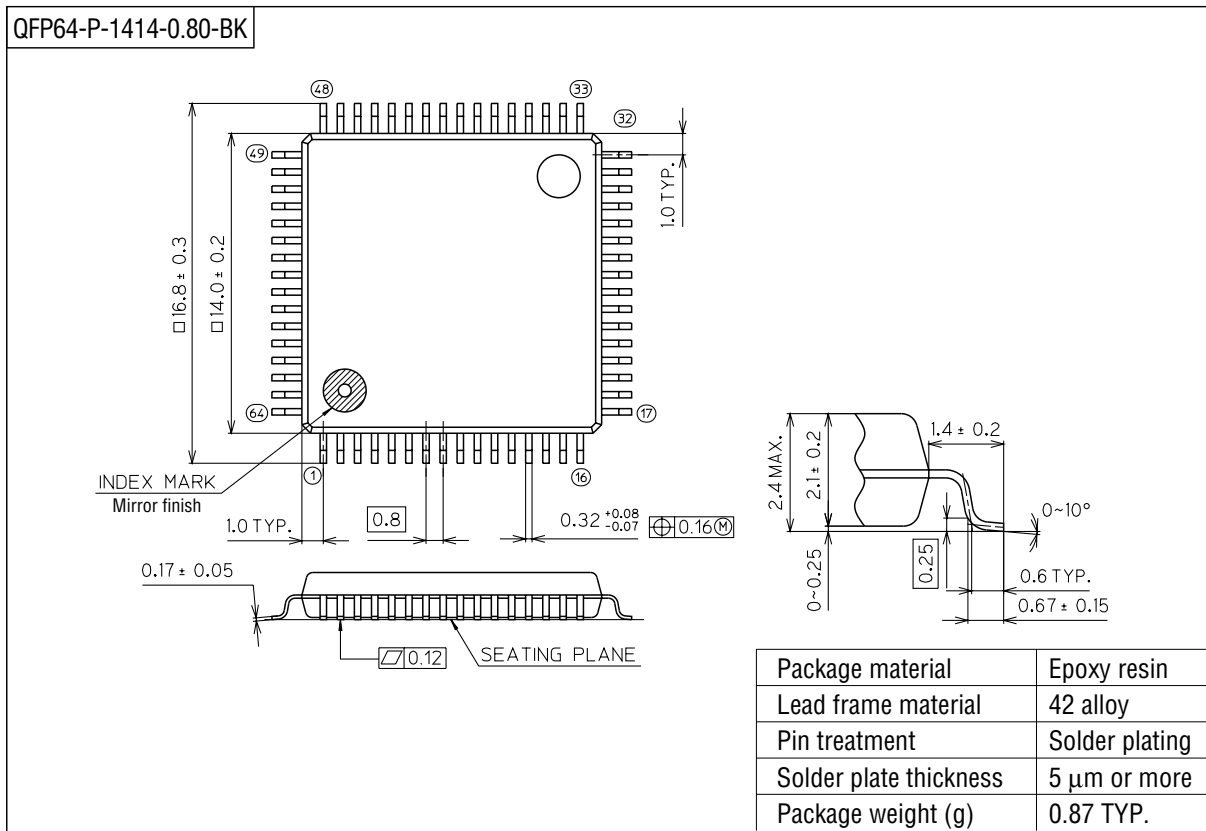

Notes for Mounting the Surface Mount Type Package

The SOP, QFP, TSOP, SOJ, QFJ (PLCC), SHP and BGA are surface mount type packages, which are very susceptible to heat in reflow mounting and humidity absorbed in storage. Therefore, before you perform reflow mounting, contact Oki's responsible sales person for the product name, package name, pin number, package code and desired mounting conditions (reflow method, temperature and times).