

MSM9004-01/02**1/3, 1/4 DUTY LCD DRIVER WITH 4-DOT COMMON DRIVER AND 49-DOT SEGMENT DRIVER****GENERAL DESCRIPTION**

The MSM9004-01/02 is an LCD driver for dynamic display with a 1/3 or 1/4 duty select function. When the 1/3 duty is selected, it can display up to 147 segments, and when the 1/4 duty is selected, up to 196 segments.

FEATURES

- Logic power supply voltage (V_{DD}) : 5.0 V \pm 10%
- LCD drive power supply voltage (V_{LCD}) : 3.7 V to 5.5 V
- Serial transfer clock frequency : 2 MHz max.
- LCD output resistance
 - Common driver : 20 k Ω
 - Segment driver : 60 k Ω
- Display duty : 1/3, 1/4 selectable
- LCD segment output : 49
- Maximum number of display segments
 - For 1/3 duty : 147 segments max.
 - For 1/4 duty : 196 segments max.
- Display blanking terminal attached
- Operating temperature range : -40 to +85 $^{\circ}$ C
- Interface with microcontroller
 - MSM9004-01 : LOAD, DATA, CLOCK1, CLOCK2
 - MSM9004-02 : LOAD, DATA, CLOCK2
- System clock
 - MSM9004-01 : external input
 - MSM9004-02 : internal oscillation circuit (external resistor and capacitor required)
- Package:
 - 64-pin plastic QFP (QFP64-P-1414-0.80-BK) (Product name : MSM9004-01GS-BK)
 - (Product name : MSM9004-02GS-BK)
- Comparison of device codes and functions

Function Device code	LCD segment output		Duty		System clock	
	50	49	1/3	1/4	External input	Internal oscillation circuit
MSM9004-01	—	○	○	○	○	—
MSM9004-02	—	○	○	○	—	○
MSM9004-03	○	—	—	○	○	—
MSM9004-04	○	—	—	○	—	○

BLOCK DIAGRAM

MSM9004-01

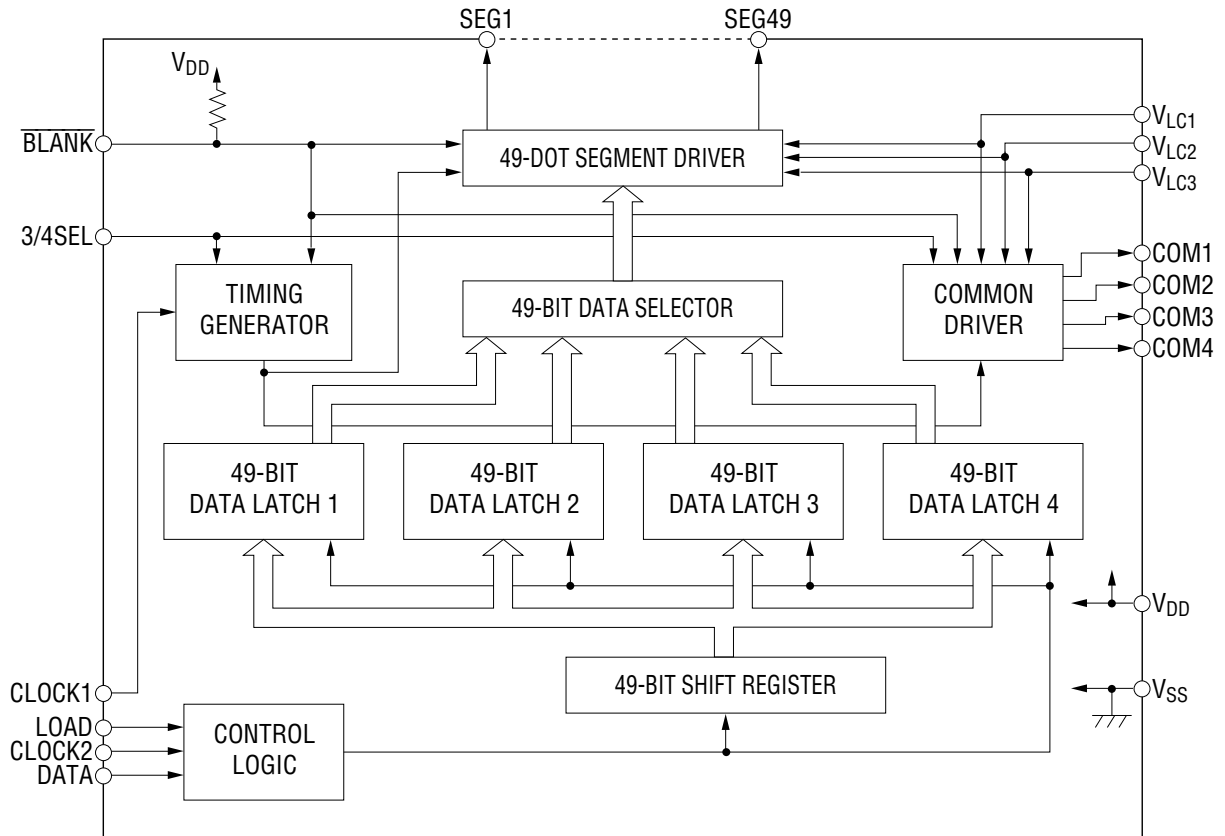

BLOCK DIAGRAM

MSM9004-02

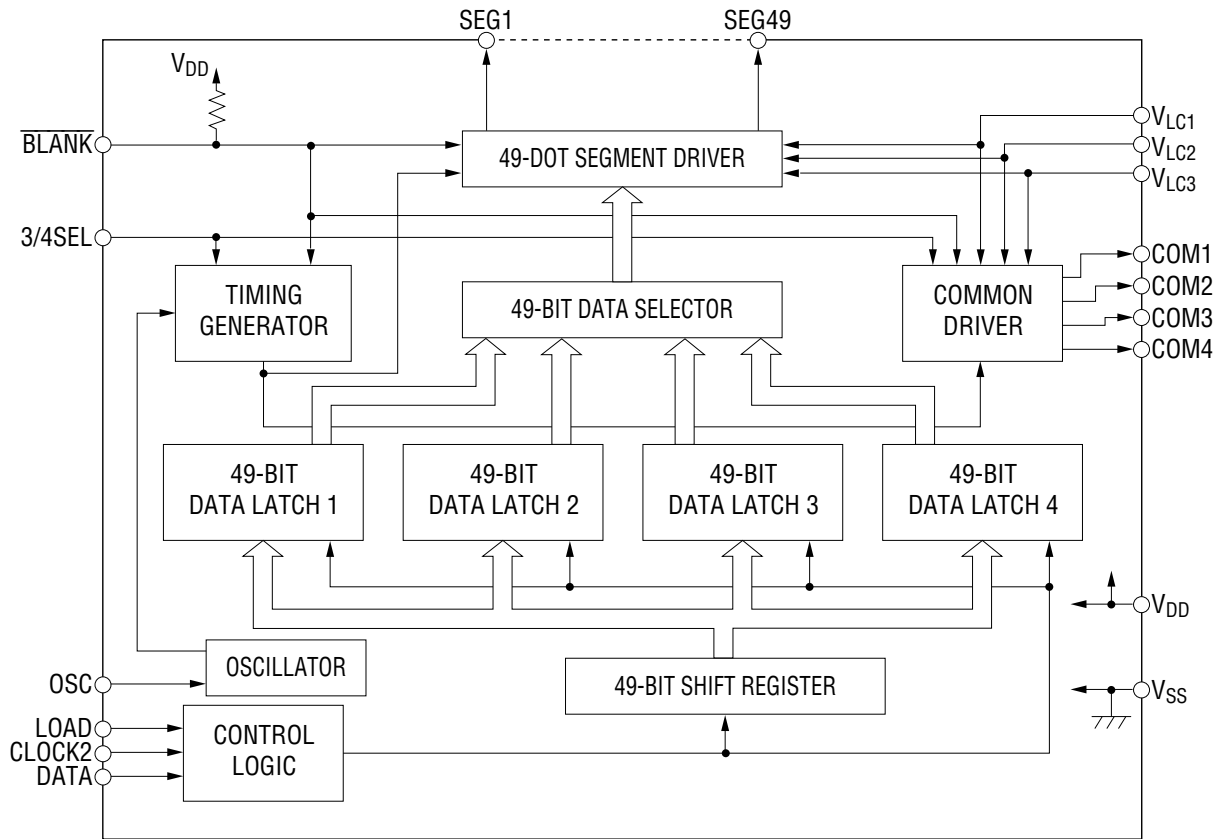

MSM9004-01

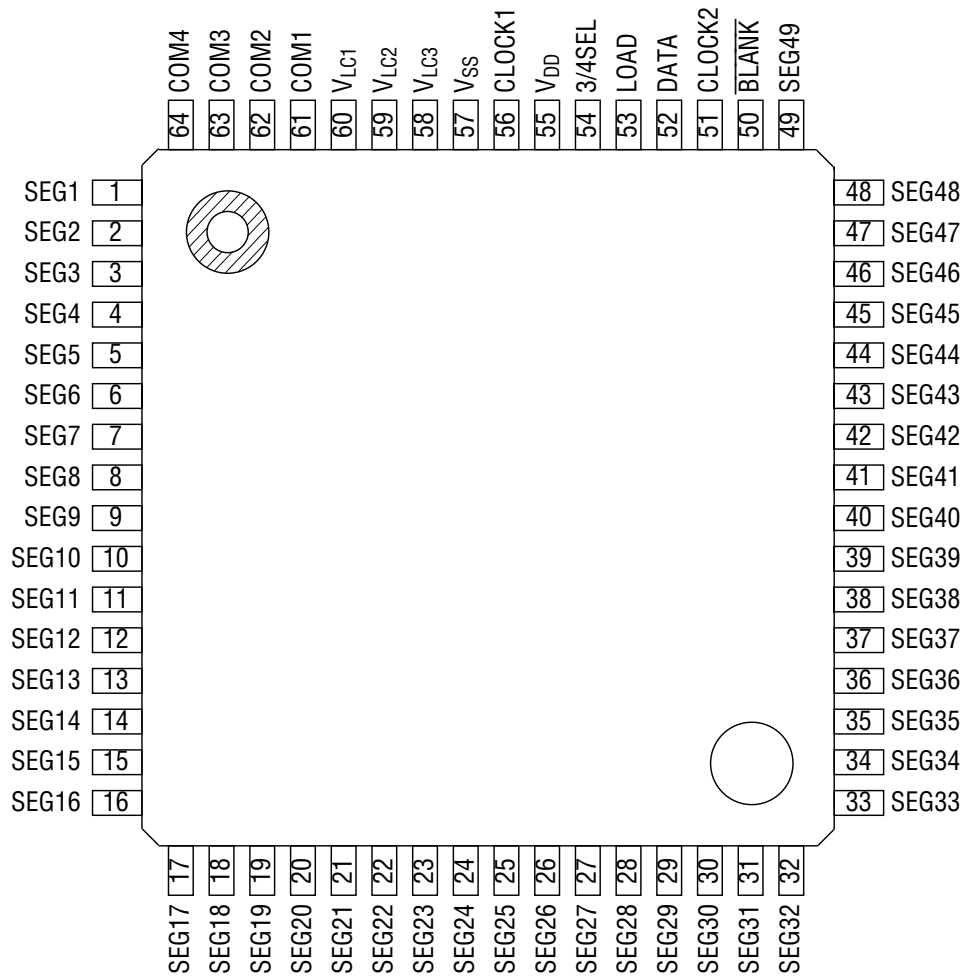

64-Pin Plastic QFP

PIN CONFIGURATION (TOP VIEW)

MSM9004-02

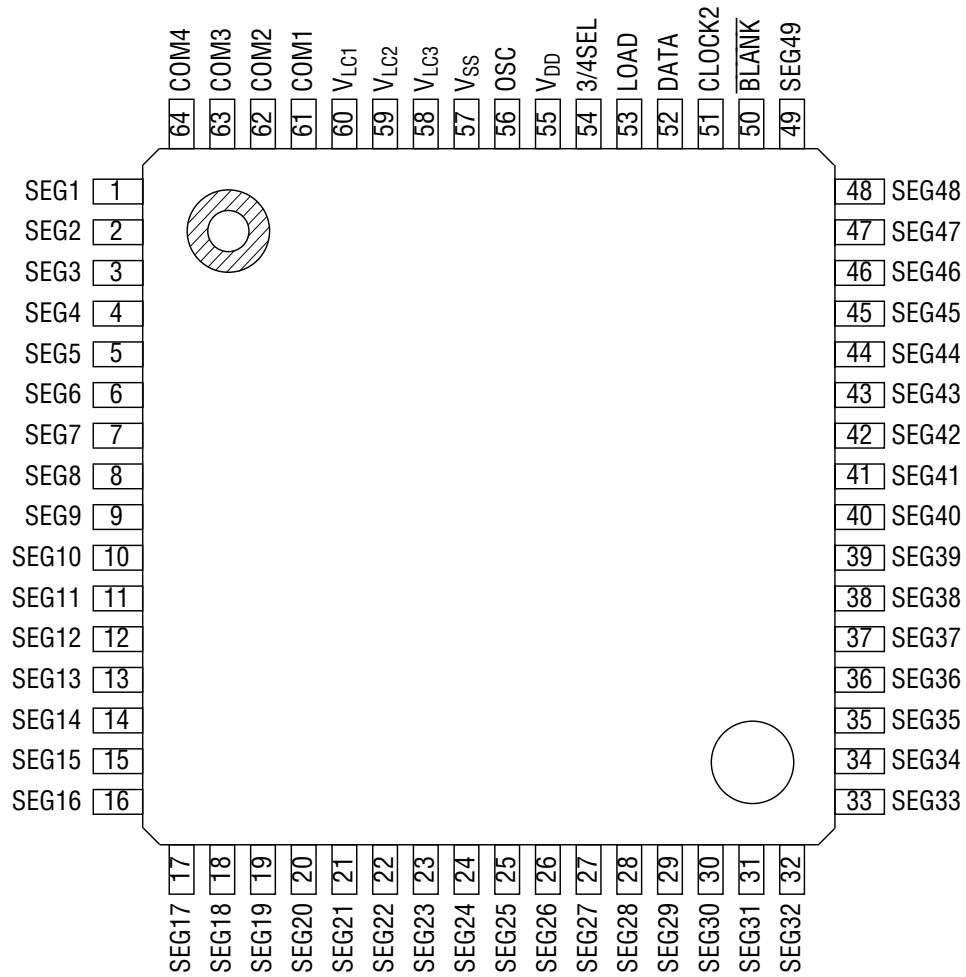

64-Pin Plastic QFP

PIN DESCRIPTIONS

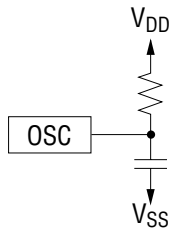
Pin	Symbol	Type	Connected to	Description
56	CLOCK1 *1	I	Micro-controller	System clock input pin. For details, see "MSM9004-02 Oscillation Circuit Characteristics".
56	OSC *2	I	External resistor Capacitor	Pin for oscillation. Connecting the external resistor and capacitor to configure the oscillation circuit. Connect the resistor and capacitor as shown in the right figure. Make the length of wiring between this pin and the external resistor and capacitor as short as possible. <div style="float: right; text-align: center;">  <p>The diagram shows a rectangular box labeled 'OSC' connected to a vertical line. This line has a resistor symbol (zigzag) connected to an upward-pointing arrow labeled 'V_{DD}'. Below the resistor, the line continues to a capacitor symbol (two parallel lines) connected to a downward-pointing arrow labeled 'V_{SS}'.</p> </div>
52	DATA	I	Micro-controller	Serial data input. For details on the configuration of input data, see "Data Configuration".
51	CLOCK2	I	Micro-controller	Shift clock input (Schmitt circuit included). Input data is read synchronizing with the rising edge of this clock.
53	LOAD	I	Micro-controller	Load signal input (Schmitt circuit included). Serial input data is transferred to the display latch when this LOAD signal is at a "H" level.
50	BLANK	I	—	Input pin for turning off all segments. All segments turn off, regardless of the display data, when this pin is at a "L" level, and all segments return to the status before turning off.
54	3/4SEL	I	—	Input pin for selecting 1/3 or 1/4 duty. 1/3 duty drive is selected when this pin is at a "H" level, and 1/4 duty drive is selected when this pin is at a "L" level.
61 to 64	COM1-4	O	LCD	LCD common outputs. Leave COM4 open for 1/3 duty drive.
1 to 49	SEG1-49	O	LCD	LCD segment outputs.
60 59 58	V _{LC1} V _{LC2} V _{LC3}	Power supply	—	Bias power supply pins for driving the LCD. Conditions for bias voltage are as follows : $3.7V \leq V_{DD} - V_{LC3} \leq 5.5V$ $V_{LC1} = V_{DD} - \frac{1}{3}(V_{DD} - V_{LC3})$ $V_{LC2} = V_{DD} - \frac{2}{3}(V_{DD} - V_{LC3})$ $V_{LC3} \geq V_{SS}$
55 57	V _{DD} V _{SS}	Power supply	—	Power supply pins. Normally used as V _{DD} = 4.5 to 5.5 V and V _{SS} = 0 V.

*1: Applied to MSM9004-01.

*2: Applied to MSM9004-02.

ABSOLUTE MAXIMUM RATINGS

Parameter	Symbol	Condition	Rating	Unit
Power Supply Voltage	V_{DD}	—	-0.3 to +6.5	V
LCD Driver Voltage	V_{LCD}	—	-0.3 to $V_{DD} + 0.3$	V
Input Voltage	V_{IN}	—	-0.3 to $V_{DD} + 0.3$	V
Power Dissipation	P_D	$T_a = +85^\circ\text{C}$	450	mW
Storage Temperature	T_{STG}	—	-55 to 150	$^\circ\text{C}$

RECOMMENDED OPERATING CONDITIONS

Parameter	Symbol	Condition	Range	Unit
Power Supply Voltage	V_{DD}	—	4.5 to 5.5	V
LCD Driver Voltage	$V_{LCD} * 1$	* 2	3.7V to $V_{DD} * 3$	V
System Clock Frequency	f_{CP1}	Applied to MSM9004-01	1.5 to 4.3	kHz
Self Oscillation Frequency	f_{OSC}	Applied to MSM9004-02	1.5 to 4.3	kHz
Shift Frequency (Max)	f_{CP2}	—	2.0	MHz
Operating Temperature	T_{op}	—	-40 to +85	$^\circ\text{C}$

*1: $V_{DD} - V_{LC3}$

*2: The following relationship must be kept:

$$V_{DD} > V_{LC1} > V_{LC2} \geq V_{SS}$$

$$V_{LC1} = V_{DD} - \frac{1}{3} (V_{DD} - V_{LC3})$$

$$V_{LC2} = V_{DD} - \frac{2}{3} (V_{DD} - V_{LC3})$$

$$V_{LC3} = V_{DD} - \frac{3}{3} (V_{DD} - V_{LC3})$$

*3: V_{DD} is the reference potential for the LCD driving voltage. To decide the LCD driving voltage, change the voltage between V_{LC3} and V_{SS} ($V_{LC3} > 0$).

ELECTRICAL CHARACTERISTICS

DC Characteristics (MSM9004-01)

(Ta= -40 to +85°C, V_{DD}=4.5 to 5.5 V, V_{DD}-V_{LC3}=3.7 V to V_{DD})

Parameter	Symbol	Condition	Min.	Max.	Unit	Applicable pin
"H" Input Voltage	V _{IH1}	—	0.8V _{DD}	V _{DD}	V	LOAD, CLOCK2 DATA, 3/4SEL <u>BLANK</u>
	V _{IH2}	—	0.85V _{DD}	V _{DD}	V	CLOCK1
"L" Input Voltage	V _{IL1}	—	0.0	0.2V _{DD}	V	LOAD, CLOCK2 DATA, 3/4SEL <u>BLANK</u>
	V _{IL2}	—	0.0	0.15V _{DD}	V	CLOCK1
"H" Input Current	I _{IH1}	V _{IN} =V _{DD}	-1.0	1.0	μA	LOAD, CLOCK1 CLOCK2, DATA 3/4SEL
	I _{IH2}	V _{IN} =V _{DD}	-3.0	3.0	μA	<u>BLANK</u>
"L" Input Current	I _{IL1}	V _{DD} =5.5 V, V _{IN} =0 V	-1.0	1.0	μA	LOAD, CLOCK1 CLOCK2, DATA 3/4SEL
	I _{IL2}	V _{DD} =5.5 V, V _{IN} =0 V	-160	-20	μA	<u>BLANK</u>
ON Resistance (SEG)	R _{ONV0}	I _O =-10 μA	—	60	kΩ	SEG1-49
	R _{ONV1}	I _O =±10 μA				
	R _{ONV2}	I _O =±10 μA				
	R _{ONV3}	I _O = 10 μA				
ON Resistance (COM)	R _{ONV0}	I _O =-30 μA	—	20	kΩ	COM1-4
	R _{ONV1}	I _O =±30 μA				
	R _{ONV2}	I _O =±30 μA				
	R _{ONV3}	I _O = 30 μA				
Dynamic Supply Current	I _{DD}	f _{CP1} =2.4 kHz * 1 f _{CP2} =1 MHz 1/4 duty COM1-4 : No Load SEG1-49 : No Load	—	0.65	mA	V _{DD}

* 1 For input data, input a logic "0" and a logic "1" to LCD display bits alternately. The t_r and t_f time for the CLOCK1, CLOCK2, DATA and LOAD pins must be less than 20ns.

DC Characteristics (MSM9004-02)

(Ta= -40 to +85°C, V_{DD}=4.5 to 5.5 V, V_{DD}-V_{LC3}=3.7 V to V_{DD})

Parameter	Symbol	Condition	Min.	Max.	Unit	Applicable pin
"H" Input Voltage	V _{IH1}	—	0.8V _{DD}	V _{DD}	V	LOAD, CLOCK2 DATA, 3/4SEL BLANK
"L" Input Voltage	V _{IL1}	—	0.0	0.2V _{DD}	V	LOAD, CLOCK2 DATA, 3/4SEL BLANK
"H" Input Current	I _{IH1}	V _{IN} =V _{DD}	-1.0	1.0	μA	LOAD, CLOCK2 DATA, 3/4SEL
	I _{IH2}	V _{IN} =V _{DD}	-3.0	3.0	μA	BLANK
"L" Input Current	I _{IL1}	V _{DD} =5.5 V, V _{IN} =0 V	-1.0	1.0	μA	LOAD, CLOCK2 DATA, 3/4SEL
	I _{IL2}	V _{DD} =5.5 V, V _{IN} =0 V	-160	-20	μA	BLANK
ON Resistance (SEG)	R _{ONV0}	I _O =-10 μA	—	60	kΩ	SEG1-49
	R _{ONV1}	I _O =±10 μA				
	R _{ONV2}	I _O =±10 μA				
	R _{ONV3}	I _O = 10 μA				
ON Resistance (COM)	R _{ONV0}	I _O =-30 μA	—	20	kΩ	COM1-4
	R _{ONV1}	I _O =±30 μA				
	R _{ONV2}	I _O =±30 μA				
	R _{ONV3}	I _O = 30 μA				
Dynamic Supply Current	I _{DD}	f _{CP2} =1 MHz 1/4 duty COM1-4 : No Load SEG1-49 : No Load	—	1.00	mA	V _{DD}

* 1: For input data, input a logic "0" and a logic "1" to LCD display bits alternately.
 External resistor for oscillation : R_O = 62 kΩ
 External capacitor for oscillation : C_O = 0.01 μF
 The t_r, and t_f time for the CLOCK2, DATA and LOAD pins must be less than 20ns.
 The current that flows through the external resistor and capacitor is not included.

AC Characteristics

($T_a = -40$ to $+85^\circ\text{C}$, $V_{DD} = 4.5$ to 5.5 V, $V_{DD} - V_{LC3} = 3.7$ V to V_{DD})

Parameter	Symbol	Condition	Min.	Max.	Unit
System Clock Frequency	f_{CP1}	Not applied to MSM9004-02	1.5	4.3	kHz
System Clock Pulse Width	t_{WCP1}	Not applied to MSM9004-02	1.0	—	μs
Data Clock Frequency	f_{CP2}	—	—	2.0	MHz
Data Clock Pulse Frequency	t_{WCP2}	—	200	—	ns
Data Setup Time	t_{SU}	—	100	—	ns
Data Hold Time	t_{HD}	—	100	—	ns
Load Pulse Width	t_{WLD}	—	200	—	ns
Clock-Load Time	t_{CL}	—	200	—	ns
Load-Clock Time	t_{LC}	—	200	—	ns
Rise Time	t_r	—	—	100	ns
Fall Time	t_f	—	—	100	ns

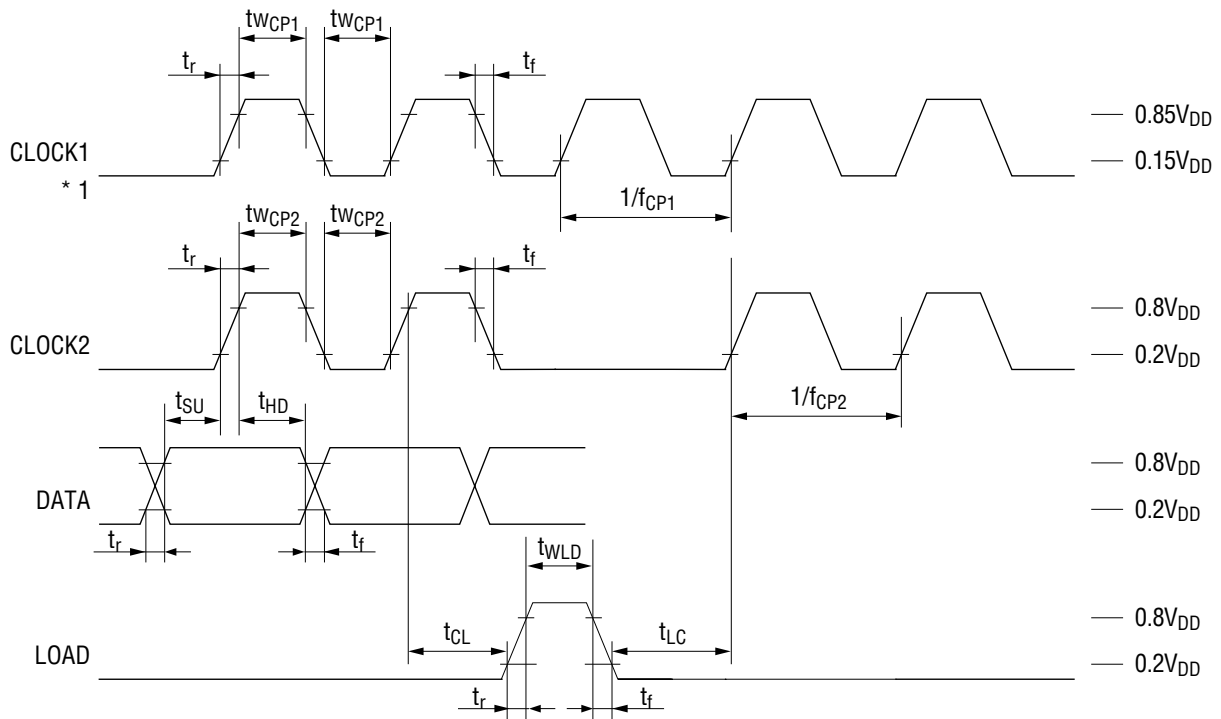

*1 Not applied to MSM9004-02.

FUNCTIONAL DESCRIPTION

Display Data Input

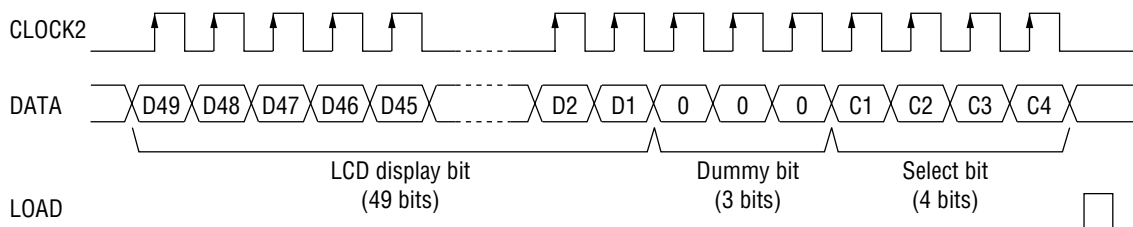

Note: Always set a logic "0" to the dummy bit.

LCD Display Bit - LCD Panel Lighting Status Correspondence Table

LCD display bit (D1 to D49)	LCD panel lighting status
1	ON
0	OFF

LCD Display Bit - Segment Output Correspondence Table

LCD display bit	D1	D2	-----	D45	D46	D47	D48	D49
Segment output	SEG1	SEG2	-----	SEG45	SEG46	SEG47	SEG48	SEG49

Select Bit - Data Latch Correspondence Table

C4	C3	C2	C1	Display data writing data latch	Corresponding common output
0	0	0	1	Data latch 1	COM1
0	0	1	0	Data latch 2	COM2
0	1	0	0	Data latch 3	COM3
1	0	0	0	Data latch 4	COM4

The select bits C1 to C4 select Data latch 1 to Data latch 4 corresponding to COM 1 to COM 4 independently. If logic "1s" are selected to multiple select bits, the LCD display bits are written to all corresponding data latches.

Example:

When logic "1s" are set to all select bits C1 to C4, and logic "0s" are set to all LCD display bits D1 to D49, logic "0s" are written to Data latch 1 to Data latch 4 by one data input. This leads to turning off the entire LCD panel.

How to Decrease Transfer Time When Unused Segments Exist

The MSM9004-01/02 can operate even if segment data is not full. Input data as shown in the figure below. In this case, the last 4 bits are the select bits.

Transfer example: for 30 segments

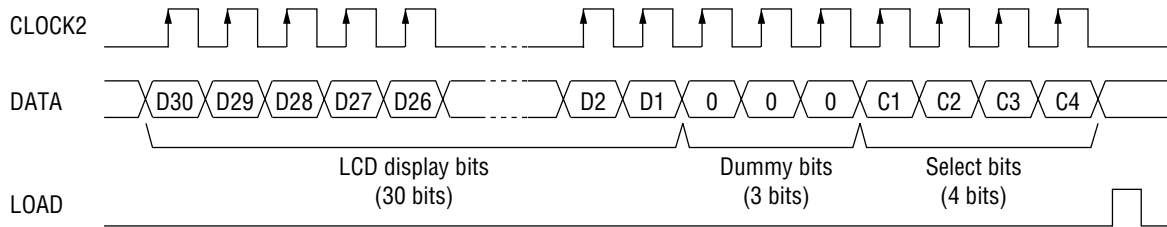

Note: Always set "0" to the dummy bits.

Recommended RC Values for MSM9004-02 Oscillation Circuit

Shown below are the recommended oscillation resistor (R_O) and capacitor (C_O) values for providing frame frequency f_{FRM} of approximately 62 Hz to 190 Hz.

- $R_O = 62 \text{ k}\Omega \pm 5\%$
- $C_O = 0.01 \text{ }\mu\text{F} \pm 5\%$

(Resistance and capacitance variations due to temperature change are not included.)

For requirements of supply voltage (V_{DD}), ambient temperature range (T_a), and frame frequency (f_{FRM}):

- $V_{DD} = 5.0 \text{ V}$
- $T_a = -40 \text{ to } +85^\circ\text{C}$
- $f_{FRM} = \frac{1}{24}$ oscillation frequency

APPLICATION CIRCUITS

MSM9004-01

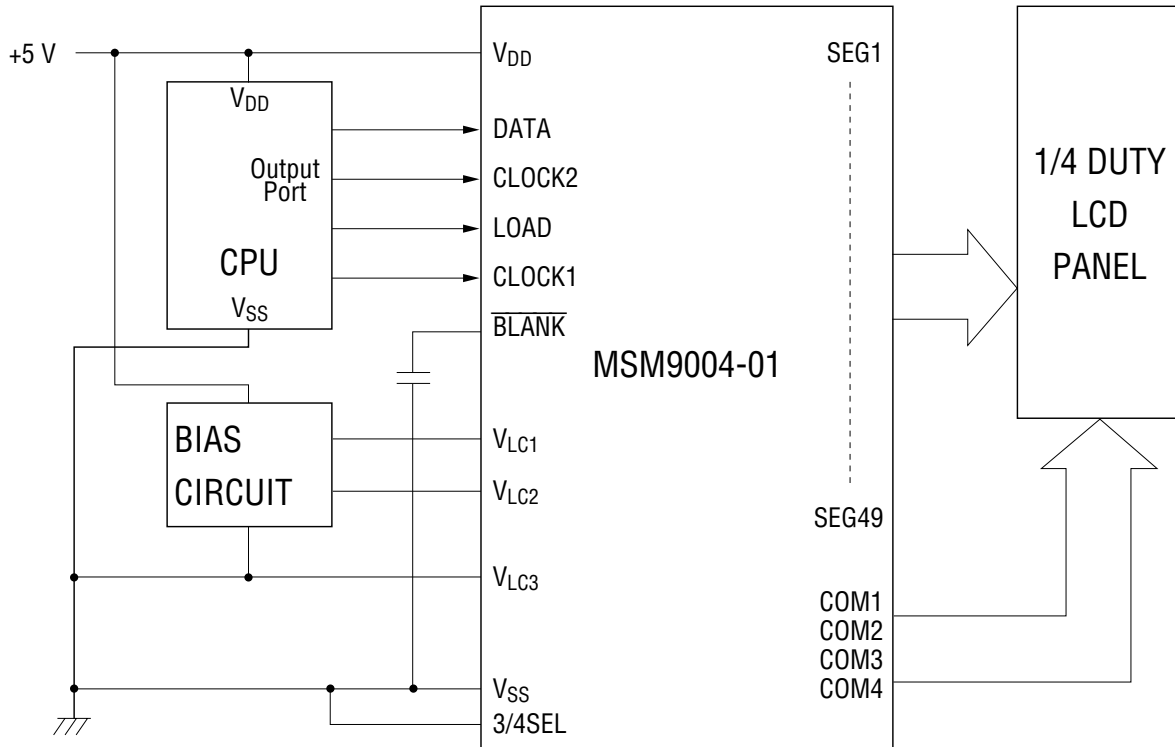

MSM9004-02

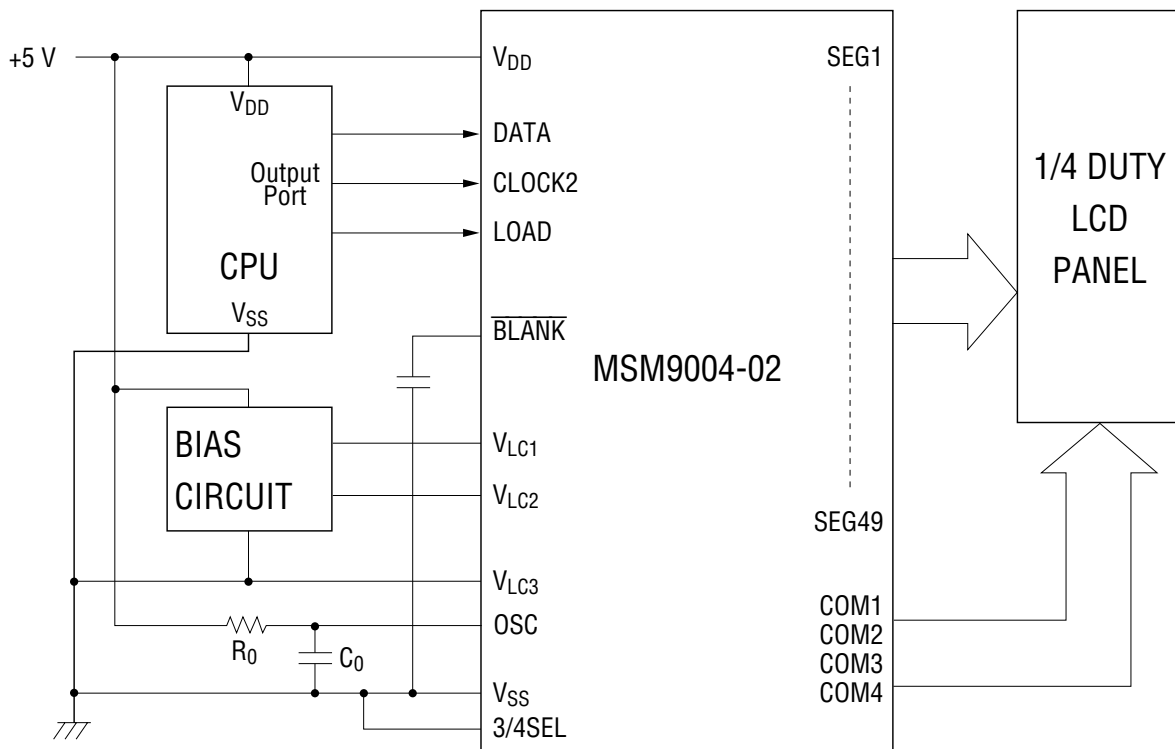

REFERENCE DATA

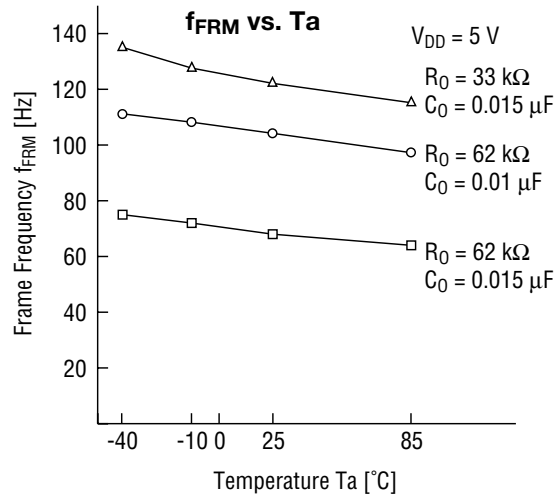
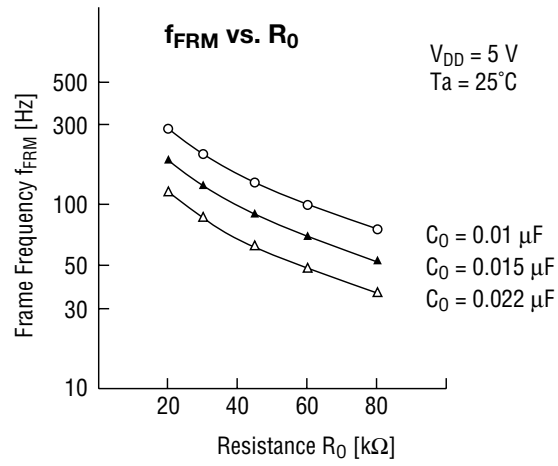

PACKAGE DIMENSIONS

(Unit : mm)

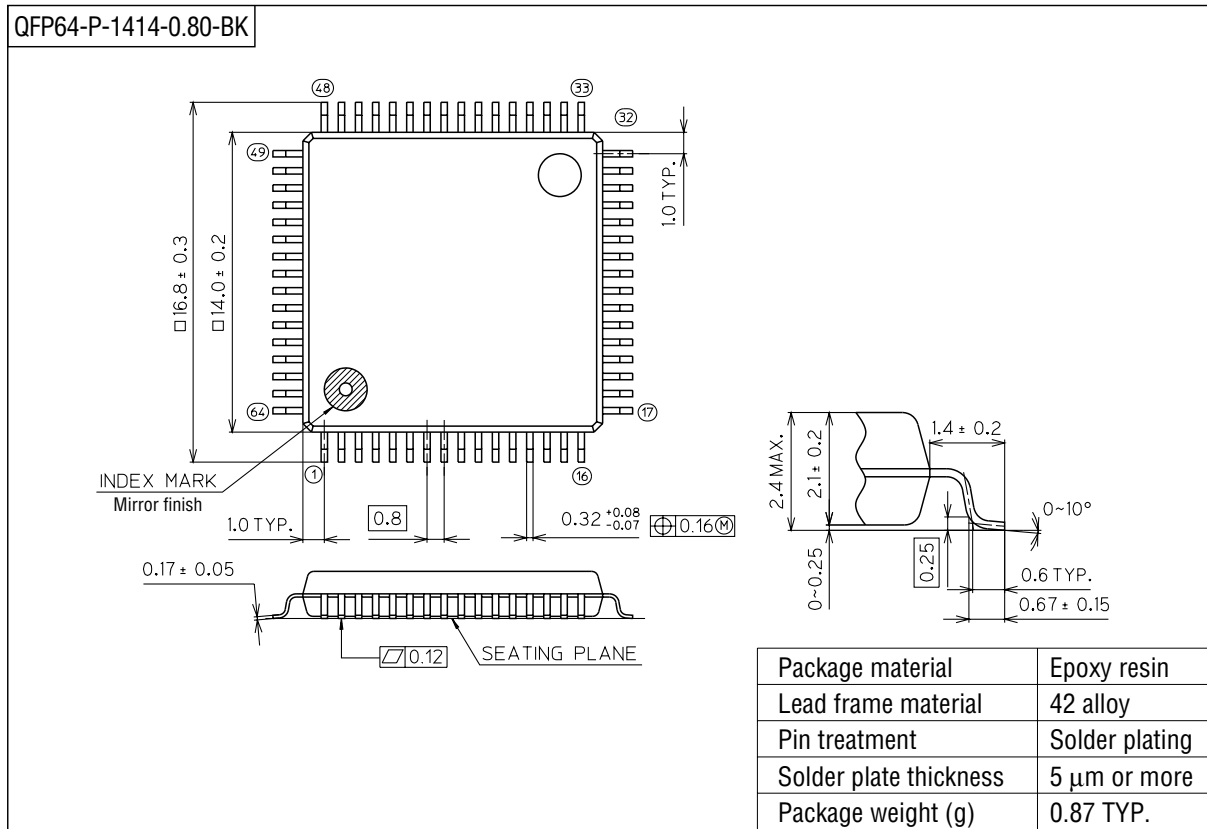

Notes for Mounting the Surface Mount Type Package

The SOP, QFP, TSOP, SOJ, QFJ (PLCC), SHP and BGA are surface mount type packages, which are very susceptible to heat in reflow mounting and humidity absorbed in storage. Therefore, before you perform reflow mounting, contact Oki's responsible sales person for the product name, package name, pin number, package code and desired mounting conditions (reflow method, temperature and times).