



UP TO 1A STEP DOWN SWITCHING REGULATOR

- UP TO 1A OUTPUT CURRENT
- OPERATING INPUT VOLTAGE FROM 4.4V TO 36V
- 3.3V / ($\pm 2\%$) / REFERENCE VOLTAGE
- OUTPUT VOLTAGE ADJUSTABLE FROM 1.2V TO 35V
- LOW DROPOUT OPERATION: 100% DUTY CYCLE
- 250KHz INTERNALLY FIXED FREQUENCY
- VOLTAGE FEEDFORWARD
- ZERO LOAD CURRENT OPERATION
- INTERNAL CURRENT LIMITING
- INHIBIT FOR ZERO CURRENT CONSUMPTION
- SYNCHRONIZATION
- PROTECTION AGAINST FEEDBACK DISCONNECTION
- THERMAL SHUTDOWN

APPLICATIONS:

- CONSUMER: STB, DVD, TV, VCR, CAR RADIO, LCD MONITORS
- NETWORKING: XDSL, MODEMS, DC-DC MODULES
- COMPUTER: PRINTERS, AUDIO/GRAPHIC CARDS, OPTICAL STORAGE, HARD DISK DRIVE
- INDUSTRIAL: CHARGERS, CAR BATTERY DC-DC CONVERTERS

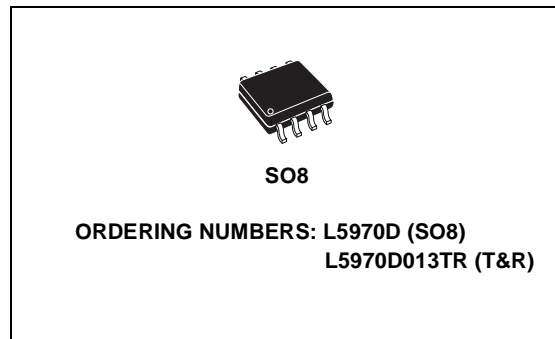

DESCRIPTION

The L5970D is a step down monolithic power switching regulator capable to deliver up to 1A at output voltages from 1.2V to 35V.

The device uses an internal P-Channel D-MOS transistor (with a typical $R_{ds(on)}$ of 250m Ω) as switching element to minimize the size of the external components.

An internal oscillator fixes the switching frequency at 250KHz.

Having a minimum input voltage of 4.4V only, it is particularly suitable for 5V bus, available in all computer related applications.

Pulse by pulse current limit with the internal frequency modulation offers an effective constant current short circuit protection.

TEST APPLICATION CIRCUIT

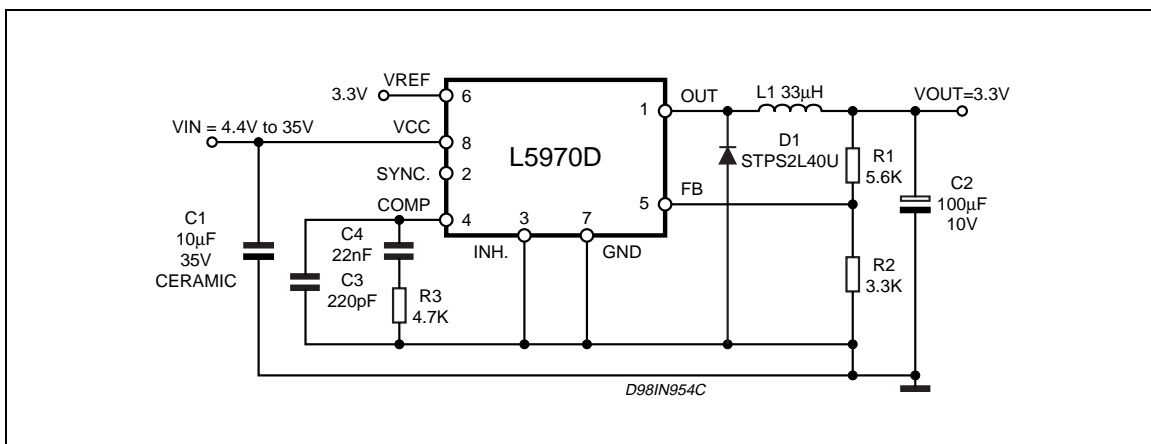

L5970D

PINS CONNECTION (Top View)

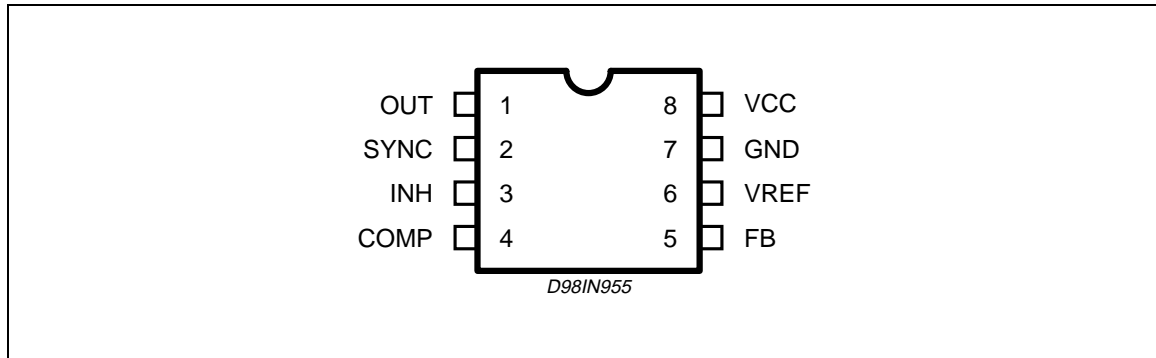

PINS FUNCTION

N.	Name	Description
1	OUT	Regulator Output.
2	SYNC	Master/slave synchronization.
3	INH	A logical signal (active high) disables the device. If INH not used the pin must be grounded. When it is open an internal pull-up disable the device.
4	COMP	E/A output for frequency compensation.
5	FB	Feedback input. Connecting directly to this pin results in an output voltage of 1.23V. An external resistive divider is required for higher output voltages.
6	V _{REF}	3.3V V _{REF} . No cap is requested for stability.
7	GND	Ground.
8	V _{CC}	Unregulated DC input voltage.

THERMAL DATA

Symbol	Parameter	Value	Unit
R _{th(j-amb)}	Thermal Resistance Junction to ambient Max.	120 (*)	°C/W

(*) Package mounted on board

ABSOLUTE MAXIMUM RATINGS

Symbol	Parameter	Value	Unit
V ₈	Input Voltage	40	V
V ₁	Output DC voltage	-1 to 40	V
	Output peak voltage at t = 0.1μs	-5 to 40	V
I ₁	Maximum output current	int. limit.	
V _{4, V5}	Analog pins	4	V
V ₃	INH	-0.3V to V _{CC}	
V ₂	SYNC	-0.3 to 4	V
P _{tot}	Power dissipation at T _{amb} ≤ 60°C	0.75	W
T _j	Operating junction temperature range	-40 to 150	°C
T _{stg}	Storage temperature range	-55 to 150	°C

ELECTRICAL CHARACTERISTICS ($T_j = 25^\circ\text{C}$, $V_{CC} = 12\text{V}$, unless otherwise specified.)(*) Specification Referred to T_j from -40 to $+125^\circ\text{C}$ (1).

Symbol	Parameter	Test Condition		Min.	Typ.	Max.	Unit
V_{CC}	Operating input voltage range	$V_o = 1.235\text{V}$; $I_o = 1\text{A}$	*	4.4		36	V
V_d	Dropout voltage	$V_{CC} = 4.4\text{V}$; $I_o = 1\text{A}$	*		0.25	0.5	V
I_l	Maximum limiting current	$V_{CC} = 4.4\text{V}$ to 36V	*	1.5	1.87	2.25	A
f_s	Switching frequency		*	212	250	280	KHz
				225	250	275	KHz
	Duty cycle			0		100	%
DYNAMIC CHARACTERISTICS (see test circuit fig. xx note 1).							
V_5	Voltage feedback	$4.4\text{V} < V_{CC} < 36\text{V}$, $20\text{mA} < I_o < 1\text{A}$		1.220	1.235	1.25	V
			*	1.198	1.235	1.272	V
η	Efficiency	$V_o = 5\text{V}$, $V_{CC} = 12\text{V}$			90		%
DC CHARACTERISTICS							
I_{qop}	Total operating quiescent current		*		3	5	mA
I_q	Quiescent current	Duty Cycle = 0; VFB = 1.5V				2.5	mA
I_{qst-by}	Total stand-by quiescent current	$V_{inh} > 2.2\text{V}$ $V_{CC} = 36\text{V}$; $V_{inh} > 2.2\text{V}$	*		50	100	μA
			*		80	150	μA
INHIBIT							
	INH Threshold voltage	Device ON				0.8	V
		Device OFF		2.2			V
ERROR AMPLIFIER							
V_{OH}	High level output voltage	$V_{FB} = 1\text{V}$		3.5			V
V_{OL}	Low level output voltage	$V_{FB} = 1.5\text{V}$				0.4	V
$I_{o\ source}$	Source output current	$V_{COMP} = 1.9\text{V}$; $V_{FB} = 1\text{V}$		200	300		μA
$I_{o\ sink}$	Sink output current	$V_{comp} = 1.9\text{V}$; $V_{FB} = 1.5\text{V}$		1	1.5		mA
I_b	Source bias current				2.5	4	μA
	DC open loop gain	$R_L = \infty$		50	65		dB
g_m	Transconductance	$I_{comp} = -0.1\text{mA}$ to 0.1mA $V_{comp} = 1.9\text{V}$			2.3		mS
SYNC FUNCTION							
	High Input Voltage	$V_{CC} = 4.4\text{V}$ to 36V		2.5		V_{REF}	V
	Low Input Voltage	$V_{CC} = 4.4\text{V}$ to 36V				0.74	V
	Slave Sink Current	$V_{sync} = 0.74\text{V}$ (2) $V_{sync} = 2.33\text{V}$		0.11		0.25	mA
				0.21		0.45	mA
	Master Output Amplitude	$I_{source} = 3\text{mA}$		2.75	3		V
	Output Pulse Width	no load, $V_{sync} = 1.65\text{V}$		0.20	0.35		μs
REFERENCE SECTION							
	Reference Voltage	$I_{REF} = 0$ to 5mA $V_{CC} = 4.4\text{V}$ to 36V		3.234	3.3	3.366	V
			*	3.2	3.3	3.399	V
	Line Regulation	$I_{REF} = 0\text{mA}$ $V_{CC} = 4.4\text{V}$ to 36V			5	10	mV
	Load Regulation	$I_{REF} = 0$ to 5mA			8	15	mV
	Short Circuit Current			10	8	30	mA

Note (1): Specification over the -40 to $+125^\circ\text{C}$ T_j Temperature range are assured by design, characterization and statistical correlation.

Note (2): Guaranteed by design.



Figure 1. Junction Temperature vs. Output Current (SO8) *)

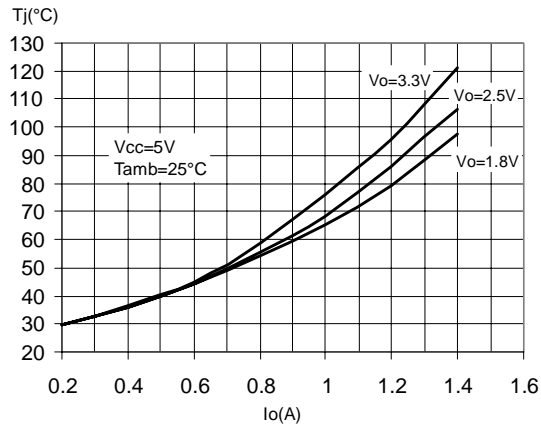

Figure 2. Junction Temperature vs. Output Current (SO8) *)

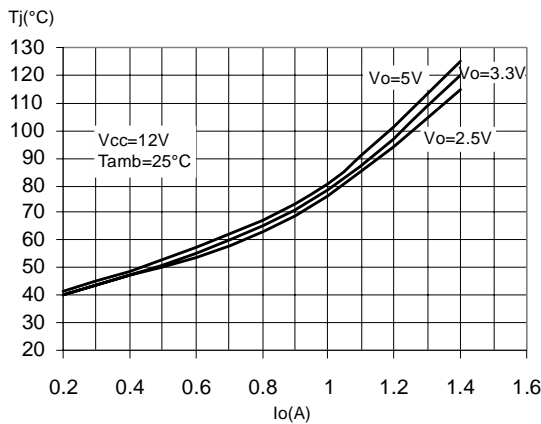

Figure 3. Junction Temperature vs. Output Current (SO8) *)

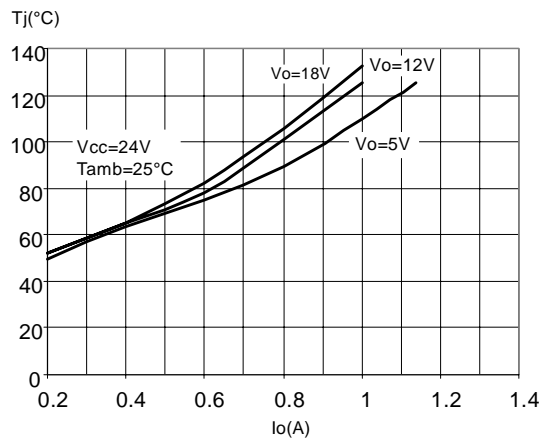

Figure 4. Load Regulation

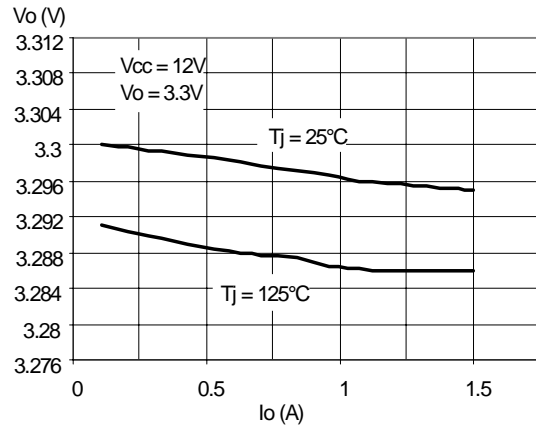

Figure 5. Line Regulation

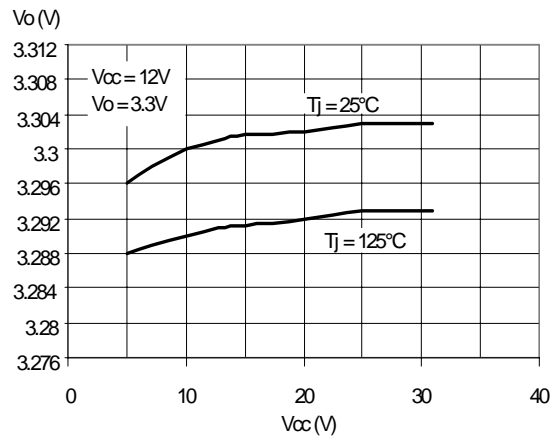
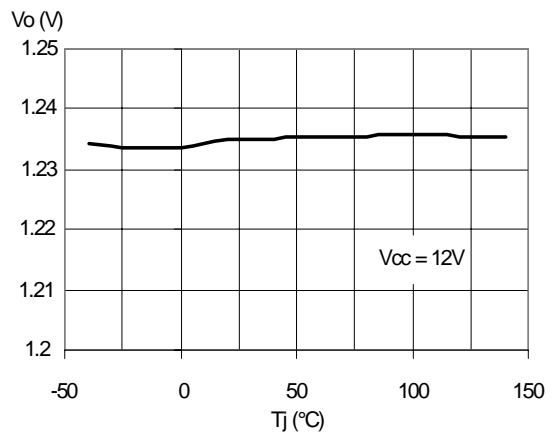
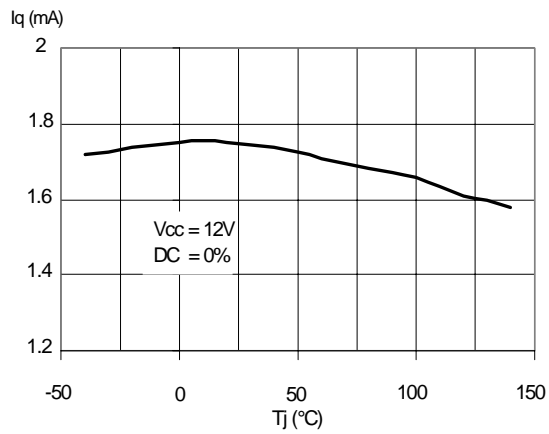
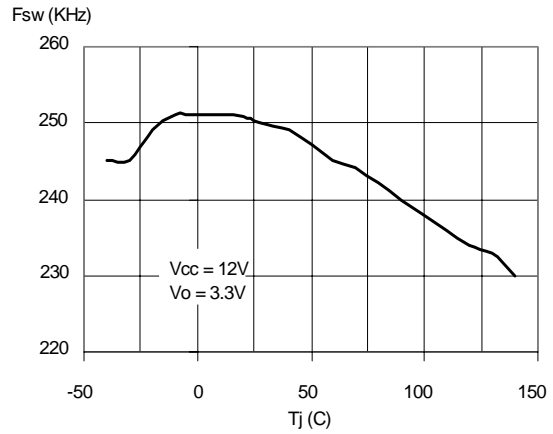
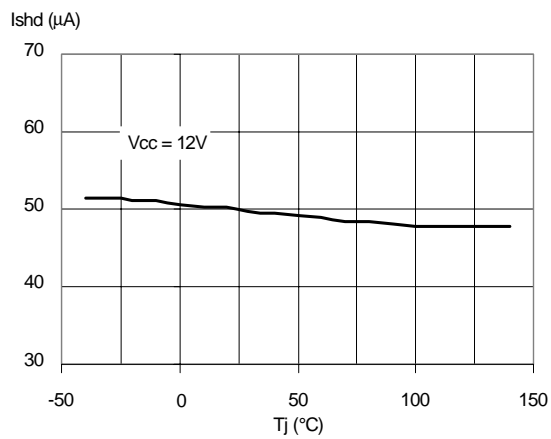

Figure 6. Output Voltage vs. Junction Temperature



*) Package mounted on demoboard

Figure 7. Quiescent Current vs. Junction Temperature**Figure 9. Switching Frequency vs. Junction Temperature****Figure 8. Shutdown Current vs. Junction Temperature**

L5970D

Figure 10. Demoboard schematic

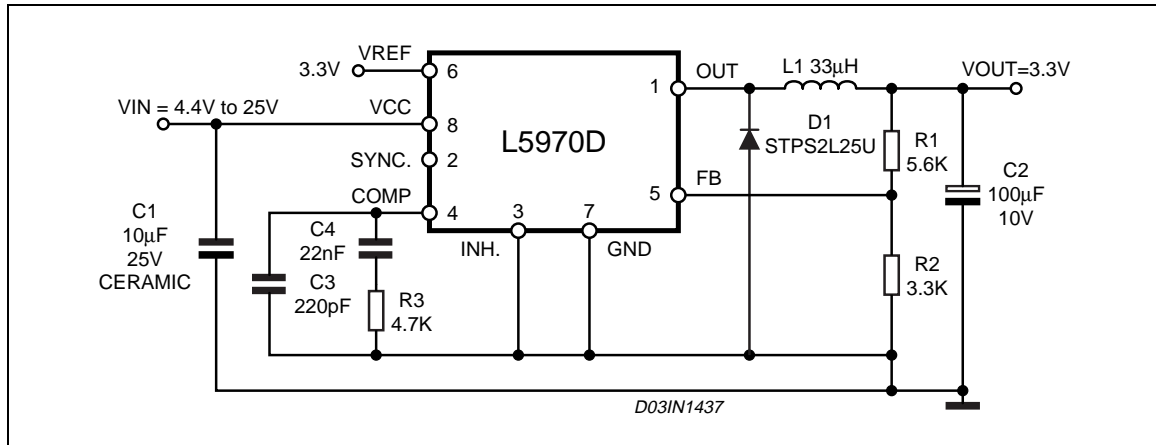

Part list demoboard

Reference	Part Number	Description	Manufacturer
C1		10µF, 25V	TOKIN
C2	POSCAP 10TPB100M	100µF, 10V	Sanyo
C3	C1206C221J5GAC	220pF, 5%, 50V	KEMET
C4	C1206C223K5RAC	22nF, 10%, 50V	KEMET
R1		5.6K, 1%, 0.1W 0603	Neohm
R2		3.3K, 1%, 0.1W 0603	Neohm
R3		4.7K, 1%, 0.1W 0603	Neohm
D1	STPS2L25U	2A, 25V	STMicroelectronics
L1	DO3316P-333	33µH, 2A	COILCRAFT

Figure 11. Efficiency vs. Output Current

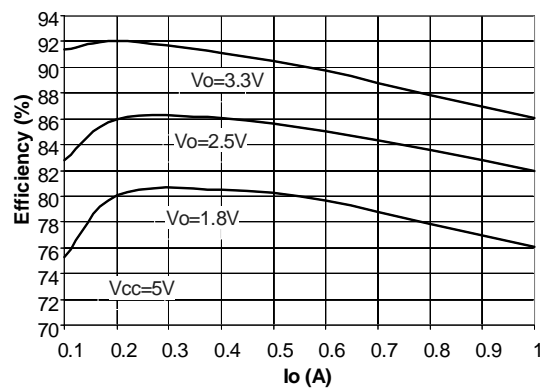

Figure 12. Efficiency vs. Output Current

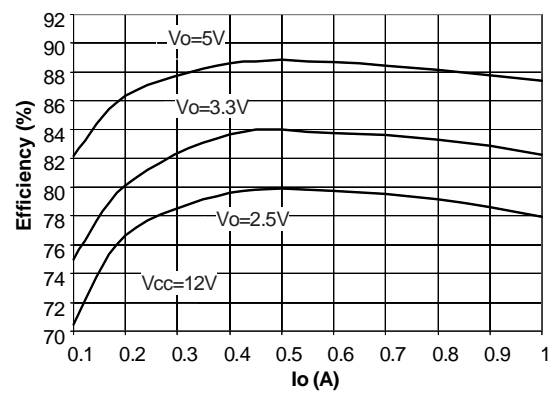

Figure 13. PCB layout (component side)

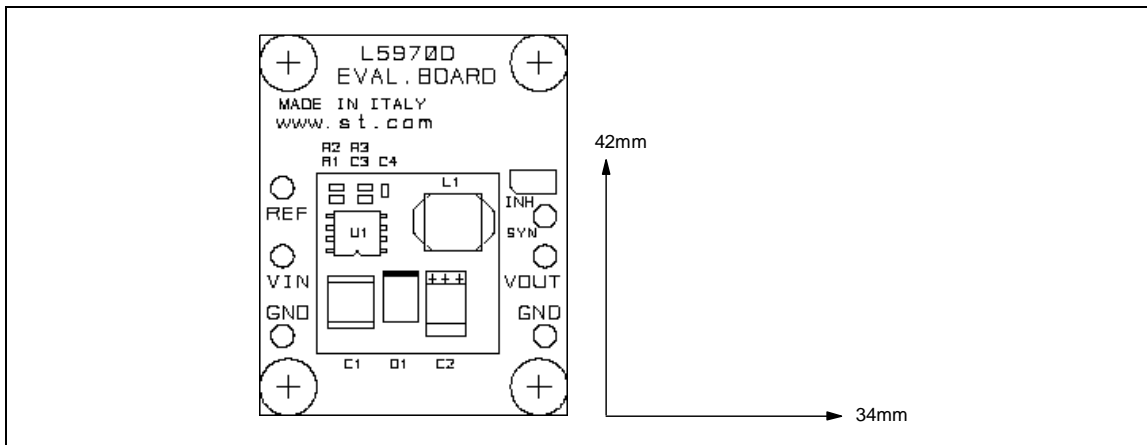

Figure 14. PCB layout (bottom side)

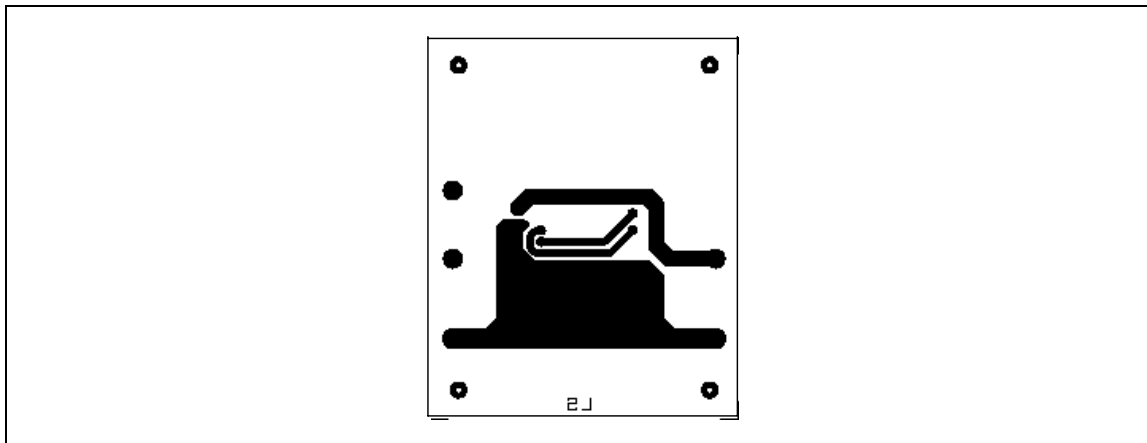
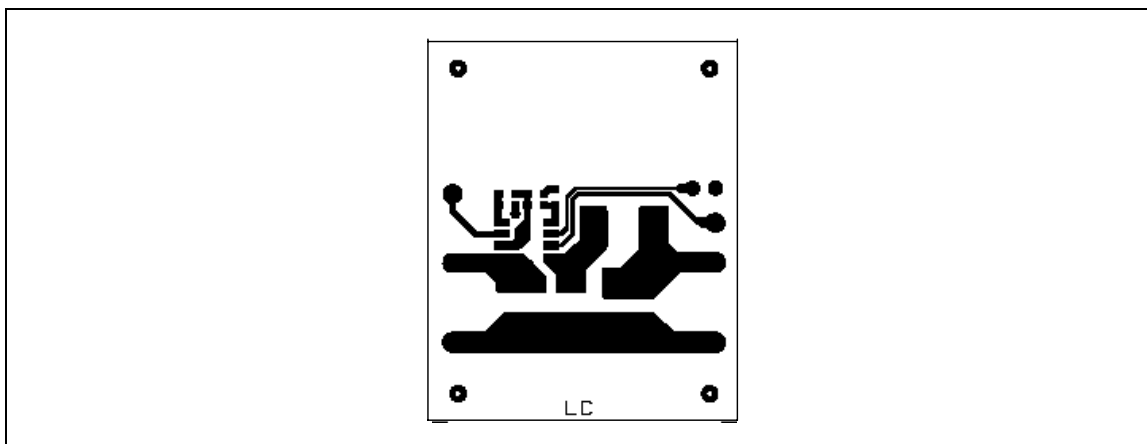

Figure 15. PCB layout (front side)



APPLICATION IDEAS

Figure 16. Dual output voltage with auxiliary winding

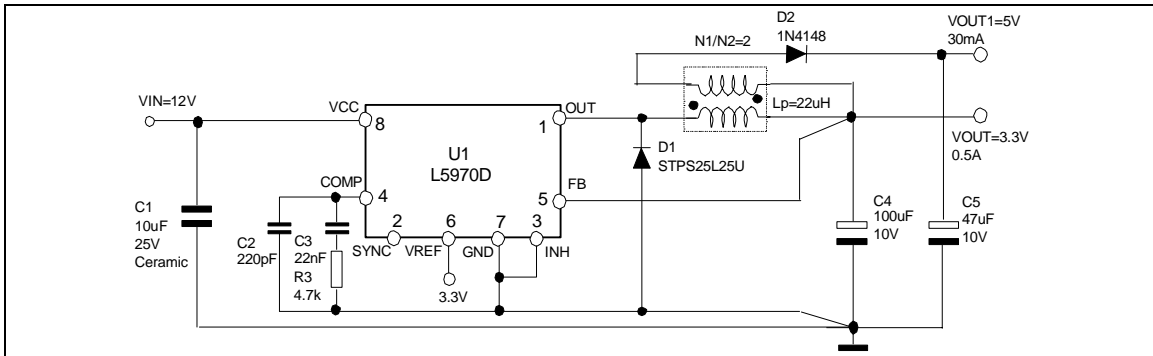

Figure 17. Buck-Boost regulator

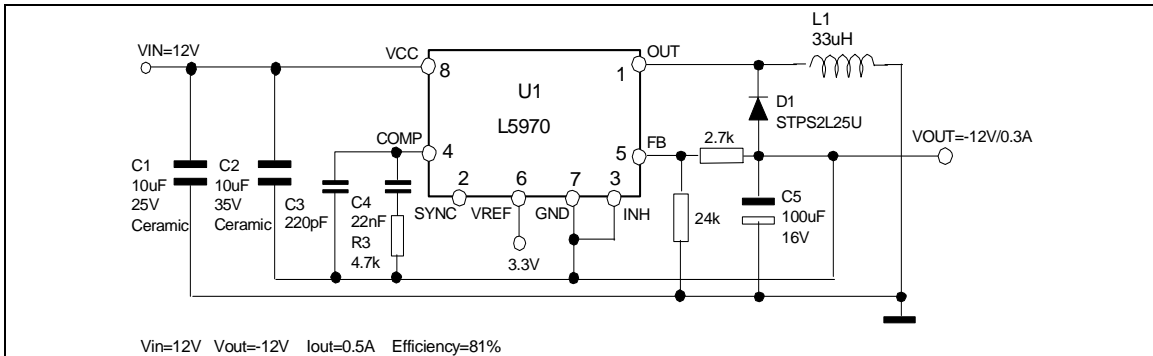

Figure 18. Positive Buck-Boost regul

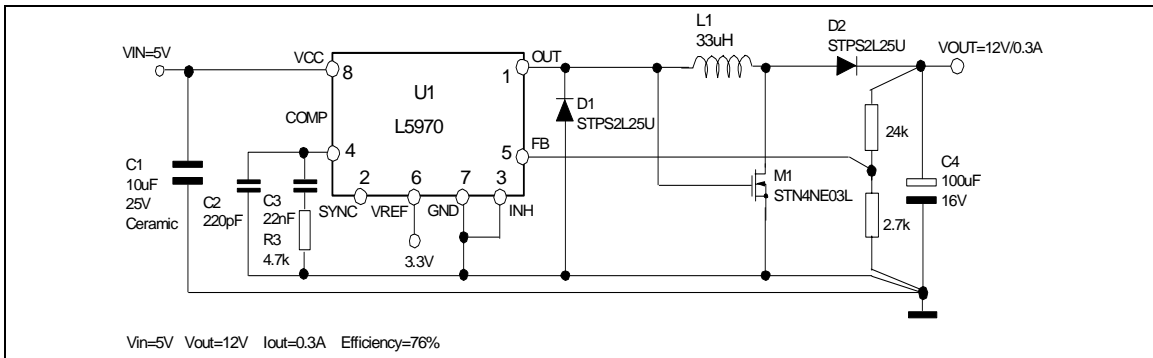
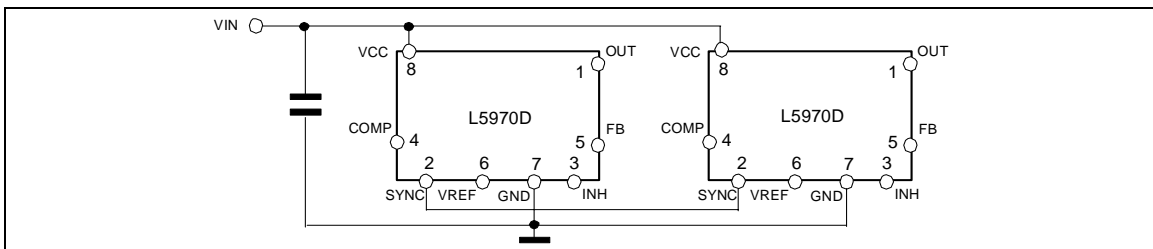
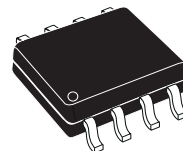

Figure 19. Synchronization example



DIM.	mm			inch		
	MIN.	TYP.	MAX.	MIN.	TYP.	MAX.
A			1.75			0.069
a1	0.1		0.25	0.004		0.010
a2			1.65			0.065
a3	0.65		0.85	0.026		0.033
b	0.35		0.48	0.014		0.019
b1	0.19		0.25	0.007		0.010
C	0.25		0.5	0.010		0.020
c1	45° (typ.)					
D (1)	4.8		5.0	0.189		0.197
E	5.8		6.2	0.228		0.244
e		1.27			0.050	
e3		3.81			0.150	
F (1)	3.8		4.0	0.15		0.157
L	0.4		1.27	0.016		0.050
M			0.6			0.024
S	8° (max.)					

OUTLINE AND MECHANICAL DATA



SO8

(1) D and F do not include mold flash or protrusions. Mold flash or protrusions shall not exceed 0.15mm (.006inch).

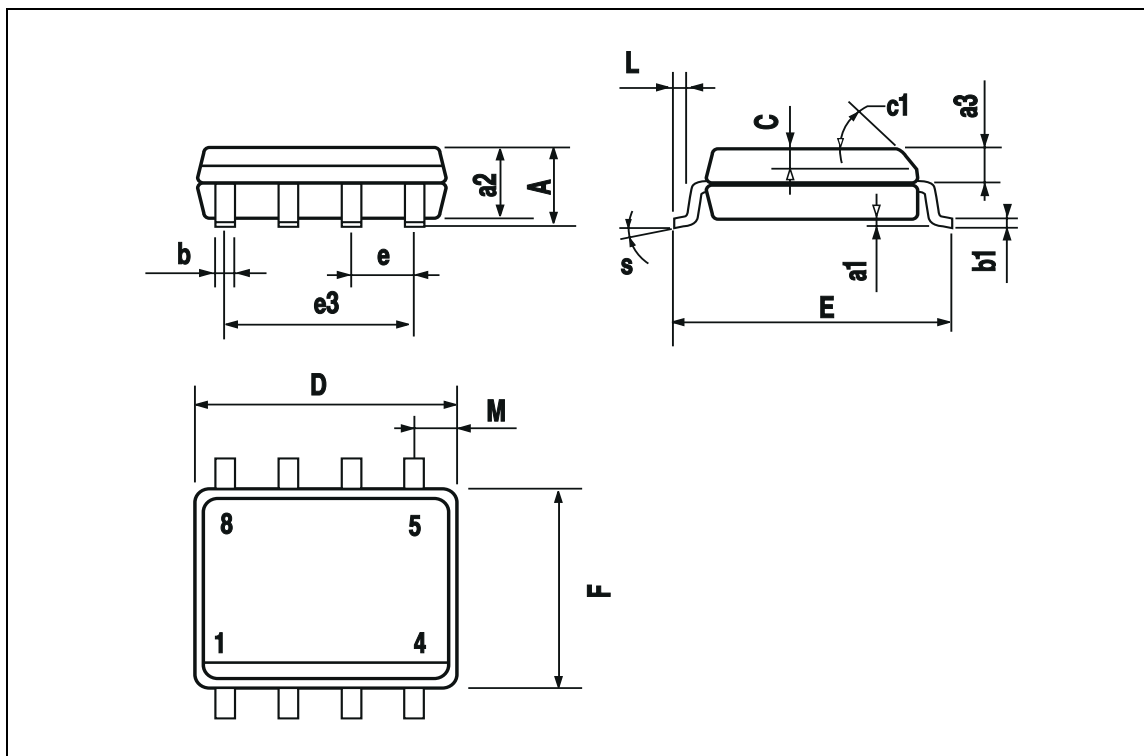

Information furnished is believed to be accurate and reliable. However, STMicroelectronics assumes no responsibility for the consequences of use of such information nor for any infringement of patents or other rights of third parties which may result from its use. No license is granted by implication or otherwise under any patent or patent rights of STMicroelectronics. Specifications mentioned in this publication are subject to change without notice. This publication supersedes and replaces all information previously supplied. STMicroelectronics products are not authorized for use as critical components in life support devices or systems without express written approval of STMicroelectronics.

STMicroelectronics acknowledges the trademarks of all companies referred to in this document.

The ST logo is a registered trademark of STMicroelectronics
© 2003 STMicroelectronics - All Rights Reserved

STMicroelectronics GROUP OF COMPANIES
Australia - Brazil - Canada - China - Finland - France - Germany - Hong Kong - India - Israel - Italy - Japan -Malaysia - Malta - Morocco -
Singapore - Spain - Sweden - Switzerland - United Kingdom - United States.
<http://www.st.com>