

# AN3389SB

## Recording/Playback Amplifier IC for 4-Head VCR

### ■ Overview

The AN3389SB is a multi-functional recording and playback IC with built-in auto-tracking interface, and automatic head selector at special playback for 4-head VCR.

### ■ Features

- Single power supply :  $V_{CC}=5V$  typ.
- Built-in AGC circuit for recording current control
- Automatic head switching for special playback
- Built-in an automatic tracking interface

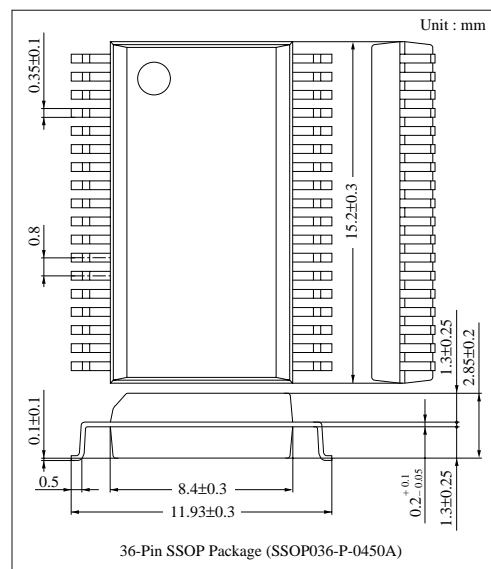

### ■ Absolute Maximum Ratings (Ta=25 °C)

Parameter	Symbol	Rating	Unit
Supply voltage <sup>Note 2)</sup>	$V_{CC}$	5.6	V
Supply current <sup>Note 2)</sup>	$I_{CC}$	160	mA
Power dissipation <sup>Note 3)</sup>	$P_D$	930	mW
Operating ambient temperature <sup>Note 1)</sup>	$T_{opr}$	-20 to + 70	°C
Storage temperature <sup>Note 1)</sup>	$T_{stg}$	-55 to + 125	°C

Note 1) Ta=25°C except operating ambient temperature and storage temperature.

Note 2) Guaranteed values if RADJ is 20kΩ or more.

If RADJ is less than 20kΩ, ensure that the stated power dissipation is not exceeded.

Note 3) The power dissipation is that of a package at Ta=70°C as mounted on the standard PC board.

### ■ Recommended Operating Range (Ta=25°C)

Parameter	Symbol	Range
Operating supply voltage range	$V_{CC}$	4.5V to 5.5V

■ Block Diagram

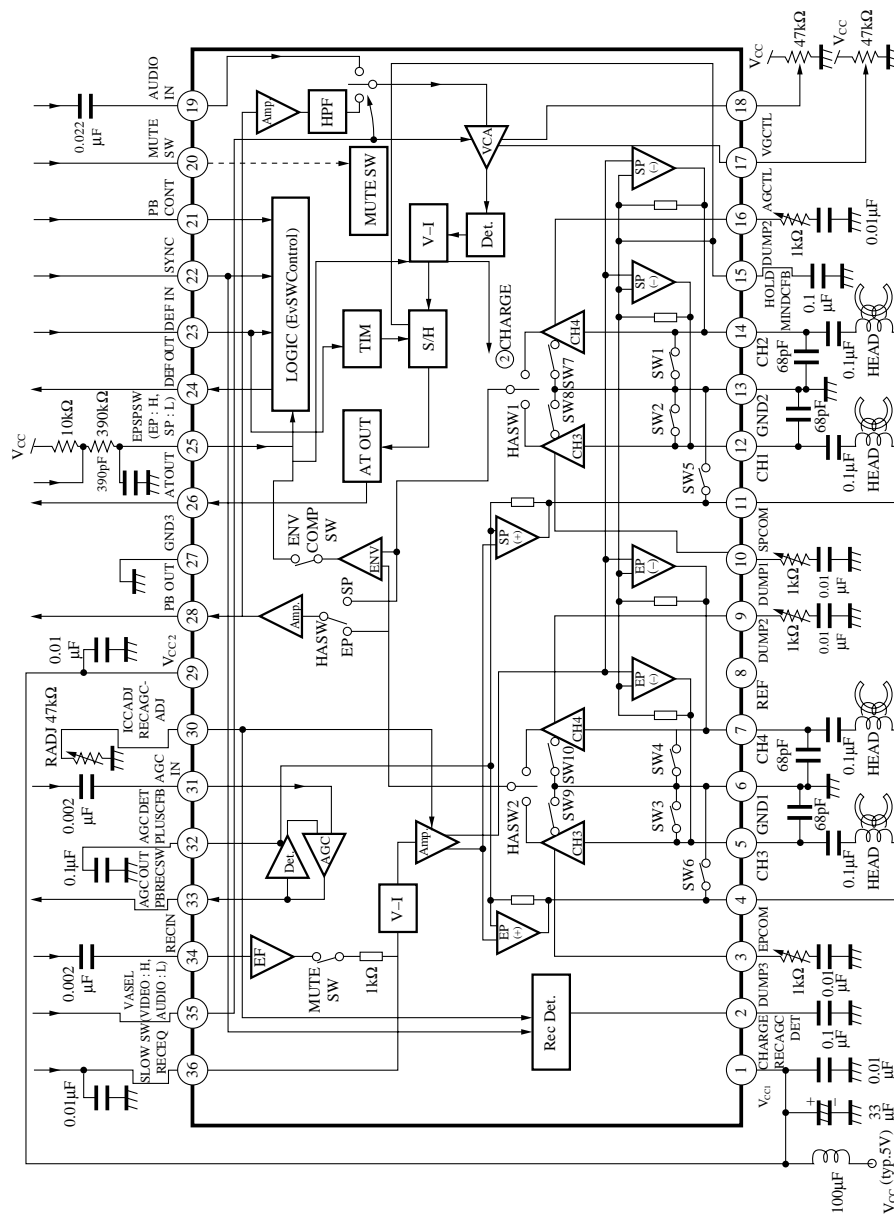

### ■ Electrical Characteristics (Ta=25±2°C)

Parameter	Symbol	Condition	min	typ	max	Unit	Note
PB quiescent current	I <sub>PCQ</sub>	At PB	60	85	110	mA	—
Rec quiescent current	I <sub>RCQ</sub>	At Rec	90	120	150	mA	—
SLOW SW input "L" (Pin36)	V <sub>SL</sub>	Input level at SLOW	0	—	1.8	V	—
Rec/PB input "L" (Pin33)	V <sub>RP</sub>	Input level at Rec	0	—	1.3	V	—
MUTE SW input "L" (Pin20)	V <sub>MS</sub>	Input level at MUTE OFF	0	—	1.4	V	—
EP/SP input "H" (Pin25)	V <sub>ESH</sub>		2.9	—	5.0	V	—
EP/SP input "L" (Pin25)	V <sub>ESL</sub>		0	—	2.1	V	—
DRUM FF input "H" (Pin23)	V <sub>DFH</sub>		1.7	—	5.0	V	—
DRUM FF input "L" (Pin23)	V <sub>DFL</sub>		0	—	1.0	V	—
SYNC input "H" (Pin22)	V <sub>SYH</sub>		1.5	—	5.0	V	—
SYNC input "L" (Pin22)	V <sub>SYL</sub>		0	—	0.7	V	—
PB CONT input "H" (Pin21)	V <sub>PCH</sub>		3.8	—	5.0	V	—
PB CONT input "M" (Pin21)	V <sub>PCM</sub>		1.9	—	3.1	V	—
PB CONT input "L" (Pin21)	V <sub>PCL</sub>		0	—	1.1	V	—
DRUM FF output "H" (Pin24)	V <sub>DOH</sub>	I <sub>OUT</sub> = -2mA	4.0	—	5.0	V	—
DRUM FF output "L" (Pin24)	V <sub>DOL</sub>	I <sub>IN</sub> = 2mA	0	—	1.0	V	—
PB voltage gain	GV	f= 4MHz, 0.5mV <sub>P-P</sub> , CH1 to CH4	57.5	60.0	62.5	dB	PB
Between CHs gain difference	ΔGV	f= 4MHz, 0.5mV <sub>P-P</sub> , CH1 to CH4	-1.0	0	1.0	dB	PB
PB output 2nd harmonics distortion	HDP2	f= 4MHz, 0.5mV <sub>P-P</sub> , 8MHz/4MHz	—	-45	-40	dB	PB
Input-conversion noise	NV	Rg= 10Ω, 1MHzBPF, output/GV	—	—	1.0	μVrms	PB
Head change-over DC unbalance	ΔV <sub>23</sub>	Rg= 10Ω, output DC difference	-100	0	100	mV	PB
SP selection in AUTO	V <sub>SP</sub>	CH1, CH4 input, Pin24 DC measurement	0	—	1.0	V	PB
EP selection in AUTO	V <sub>EP</sub>	CH2, CH3 input, Pin24 DC measurement	4.0	—	5.0	V	PB
AGC level	V <sub>AGC</sub>	f= 4MHz, 40mV <sub>P-P</sub>	255	320	390	mV <sub>P-P</sub>	PB
AGC control characteristics	ΔV <sub>AGC</sub>	f= 4MHz, 500mV <sub>P-P</sub>	0	—	2	dB	PB
AGC output 2nd harmonics distortion	HDA2	f= 4MHz, 500mV <sub>P-P</sub>	—	-50	-40	dB	PB
Rec amp. gain	IOR	f= 4MHz, 20mV <sub>P-P</sub>	260	360	465	mS	Rec
Rec AGC level	I <sub>AGC</sub>	f= 4MHz, 125mV <sub>P-P</sub> R <sub>AGC</sub> = 18kΩ	17.8	20.0	22.4	mA <sub>P-P</sub>	Rec
Rec AGC control characteristics	ΔI <sub>AGC</sub>	f= 4MHz, 250mV <sub>P-P</sub> R <sub>AGC</sub> = 18kΩ	0	—	1.2	dB	Rec
Recording current 2nd harmonics distortion	HDR2	f= 4MHz, 125mV <sub>P-P</sub> R <sub>AGC</sub> = 18kΩ	—	-40	-35	dB	Rec
Muting ratio	MR	f= 4MHz, 125mV <sub>P-P</sub> R <sub>AGC</sub> = 18kΩ	—	-45	-40	dB	Rec
Common terminal ON resistance	R <sub>C</sub>	SW5, SW6 ON	—	5	10	Ω	—
Input terminal ON resistance	R <sub>I</sub>	SW1 to SW4 ON	—	5	10	Ω	—
Output DC drift	ΔV <sub>CC</sub>	Supply voltage when Rec circuit is not operating in PB	4.5	—	—	V	—
VCA output voltage 1 (amp. gain)	V <sub>CA1</sub>	Video side 6dB amp. f= 4MHz, 1mV <sub>P-P</sub>	-0.15	0.05	0.30	V	PB
VCA output voltage 2 (amp. f characteristics)	V <sub>CA2</sub>	Video side 6dB amp. f= 4MHz/6MHz, 1mV <sub>P-P</sub>	-0.15	0.05	0.30	V	PB
VCA output voltage 3 CHARGE Pin2	V <sub>CA3</sub>	AUDIO-SP mode 1.2V <sub>P-P</sub> input VIR= 120kΩ	0.30	0.70	1.20	V	PB
VCA output voltage 4 CHARGE Pin2	V <sub>CA4</sub>	AUDIO-SP mode 0.2V <sub>P-P</sub> input VIR= 120kΩ	0.50	0.75	1.00	V	PB

### Electrical Characteristics (cont.) (Ta=25±2°C)

Parameter	Symbol	Condition	min	typ	max	Unit	Note
VCA output voltage 5 CHARGE Pin2	V <sub>CAS</sub>	AUDIO-SP mode 0.1V <sub>P-P</sub> input VIR=120kΩ	0.50	0.75	1.00	V	PB
Droop voltage HOLD Pin15	V <sub>DLP</sub>	AUDIO-SP mode 0.4V <sub>P-P</sub> input HOLDC= 0.01μF	—	50	150	mV	PB
Saturation voltage (V <sub>CC</sub> side) ATOUT Pin26	V <sub>SAT</sub>	AUDIO-SP mode 0.6V <sub>P-P</sub> input HOLDC= 0.01μF	4.6	4.9	—	V	PB
Saturation voltage(GND side) ATOUT Pin26	G <sub>SAT</sub>	AUDIO-SP mode 0.6V <sub>P-P</sub> input HOLDC= 0.01μF	—	0.1	0.4	V	PB
Offset voltage ATOUT Pin26	V <sub>OFs</sub>	AUDIO-SP mode in no signal	—	0.1	0.4	V	PB
V/A SEL input "L" (Pin35)	V <sub>ATH</sub>	Input condition	0	—	0.7	V	PB
Crosstalk	CT	HSW, HASW change-over R <sub>g</sub> =10Ω	—	—	(-35)	dB	—
PB output 3rd harmonics distortion	HDP3	f= 4MHz, 0.5mV <sub>P-P</sub> 12MHz/4MHz	—	(-45)	(-40)	dB	—
AGC output 3rd harmonics distortion	HDA3	f= 4MHz, 500mV <sub>P-P</sub>	—	(-50)	(-40)	dB	—
Recording current 3rd harmonics distortion	HDR3	f= 4MHz, 125mV <sub>P-P</sub>	—	(-45)	(-40)	dB	—
Recording current cross modulation (±fc)	CM1	f <sub>y</sub> = 4MHz, 20mA <sub>P-P</sub> f <sub>c</sub> = 630kHz, -13dB	—	—	(-50)	dB	—
Recording current cross modulation (±2fc)	CM2	f <sub>y</sub> = 4MHz, 20mA <sub>P-P</sub> f <sub>c</sub> = 630kHz, -13dB	—	—	(-50)	dB	—

Note) Values with an asterisk are typical ones and not guaranteed values.

### Pin Descriptions

Pin No.	Pin name	Pin No.	Pin name
1	V <sub>CC</sub>	17	AFM signal gain control input
2	CHARGE	18	VFM signal gain control input
	Rec AGC detection	19	AFM signal input
3	Ch3 damping adjustment	20	Rec. mute switch input
4	Playback common	21	Playback mode control input
	Rec. EP (+) amp. output	22	SYNC signal input
5	Playback amp. ch3 signal input	23	DRUM FF signal input
	Rec. EP (-) amp. output	24	DRUM FF signal output
6	GND	25	EP/SP switch input
7	Playback amp. ch4 signal input	26	Automatic tracking signal output
	Rec. EP (-) amp. output	27	GND
8	Playback ref. voltage output	28	Playback amp. output
9	Ch4 damping adjustment	29	V <sub>CC</sub>
10	Ch1 damping adjustment	30	Rec. AGC level adjustment
11	Playback common	31	Playback AGC signal input
	Rec. SP (+) amp. output	32	Playback AGC detection
12	Playback amp. ch1 signal input	33	Rec. positive amp. DCFB
	Rec. SP (-) amp. output		Playback AGC signal output
13	GND		Playback/Rec. switch input
14	Playback amp. ch2 signal input	34	Rec. amp. signal input
	Rec. SP (-) amp. output	35	VFM/AFM switch input
15	HOLD	36	Slow switch input
	Rec. (-) amp. DCFB		Rec. equalization
16	Ch2 damping adjustment		

### Reference

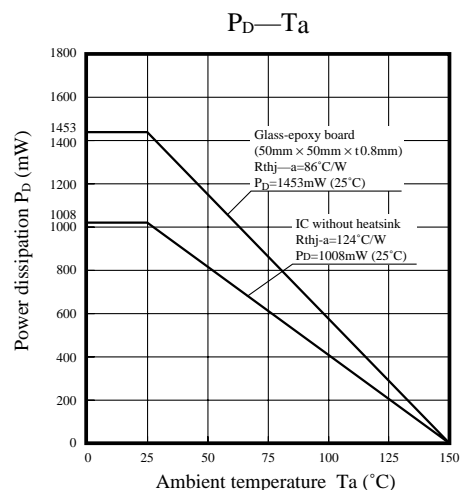

■ Pin Descriptions

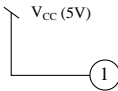
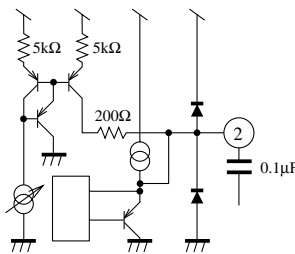
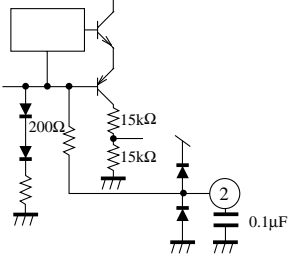
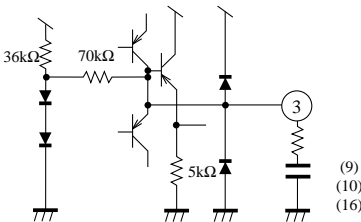
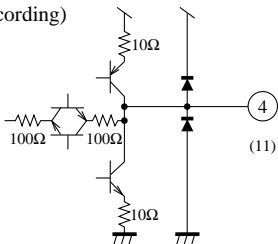
Pin No.	Pin name	DC voltage (V <sub>CC</sub> =5V)	Equivalent circuit	Description
1	V <sub>CC1</sub>	5V		Power supply input for playback and recording amplifiers
2	CHARGE	1.25V (PB)	<p>(For playback)</p> 	Integration output of automatic tracking interface peak detection signal for the playback mode. An external capacitor is connected to this pin for integration function.
2	Rec. AGC Det.		<p>(For recording)</p> 	Recording AGC detection. Connected to an external capacitor for the recording mode
3 9 10 16	DUMP3 DUMP4 DUMP1 DUMP2	1.65V (PB)		Head amplifier damping adjustment. Connected to an external resistor
4 11	EPCOM SPCOM	2.2V (Rec)	<p>(For recording)</p> 	Recording current output for the recording mode. Pin4 (EPCOM) is terminated in the SP mode, and Pin11 (SPCOM) is terminated in the EP mode.

■ Pin Descriptions (cont.)

Pin No.	Pin name	DC voltage (V <sub>CC</sub> =5V)	Equivalent circuit	Description
5 7 12 14	CH3 CH4 CH1 CH2	0.69V (PB)	<p>(For playback)</p>	Playback amplifier input for the playback mode
5 7 12 14	CH3 CH4 CH1 CH2	2.2V (Rec)	<p>(For recording)</p>	Recording current output for the recording mode
6	GND1	0V		Ground for playback and recording amplifiers in the EP mode
8	REF	3.2V		Reference voltage output for playback amplifiers
13	GND2	0V		Ground for playback and recording amplifiers in the SP mode

■ Pin Descriptions (cont.)

Pin No.	Pin name	DC voltage (V <sub>CC</sub> =5V)	Equivalent circuit	Description
15	HOLD	1.25V (PB)	<p>(For playback)</p>	Peak hold of automatic tracking interface peak detection integration signal for the playback mode. An external capacitor is connected to this pin for peak hold function.
15	MIN DCFB	2.2V (Rec)	<p>(For recording)</p>	Connecting to an external capacitor for recording amplifier DC voltage feedback at the recording mode
17 18	AGCTL VGCTL	2.5V 2.5V		Gain control of automatic tracking interface amplifiers. Pin 17 (AGCTL) controls the gain in the audio mode, and Pin 18 (VGCTL) controls the gain in the video mode.
19	AUDIO -IN	2.5V for playback, and 0.7V for recording	<p>(For playback)</p>	Automatic tracking interface audio FM signal input
20	MUTE SW	—	<p>(For recording)</p>	Mute control for the recording mode. Muting is on at low and OFF at high (open).

### ■ Pin Descriptions (cont.)

Pin No.	Pin name	DC voltage (V <sub>CC</sub> =5V)	Equivalent circuit	Description
21	PBCONT	—	<p>(For playback)</p>	Playback mode control. Manual, auto, or still/slow mode is selected when this pin is high, middle, or low respectively. Pin36 selects still or slow mode.
22	SYNC	—		SYNC signal input. Recording AGC operates when this pin is high.
23	DFF IN	—		DRUM.FF signal input
24	DFF OUT	—		Color rotation control signal output. This pin goes low when + azimuth head (ch1 or ch3) is selected, and goes high when - azimuth head (ch2 or ch4) is selected.
25	EPSPSW	5V		EP/SP mode selection control. The EP mode is selected when this pin is high, and the SP mode is selected when this pin is low.



## ■ Pin Descriptions (cont.)

Pin No.	Pin name	DC voltage (V <sub>CC</sub> =5V)	Equivalent circuit	Description
26	AT OUT	0.1V		Peak hold voltage output of automatic tracking interface peak detection integration signal for the playback mode. In the recording mode, this pin is forcibly terminated.
27	GND3	0V		Ground
28	FM OUT	3.2V for playback		Playback amplifier output
29	V <sub>CC2</sub>	5V		V <sub>CC</sub>
30	I <sub>CC</sub> ADJ Rec AGC ADJ	3.4V		Recording amplifier idle-current control as well as recording AGC level control

### ■ Pin Descriptions (cont.)

Pin No.	Pin name	DC voltage ( $V_{CC}=5V$ )	Equivalent circuit	Description
31	AGC IN	3.6V for playback		AGC amplifier input
32	AGC Det.	—	<p>(For playback)</p>	AGC amplifier detection. Connected to an external capacitor
32	PLUS DCFB	2.2V for recording		Connecting to an external capacitor for recording amplifier DC voltage feedback for the recording mode.
33	AGC OUT PB Rec SW	3.1V for playback		AGC amplifier output as well as playback/recording mode selection control. Recording mode is selected when this pin is low.
34	Rec IN	3V		Recording signal input

### ■ Pin Descriptions (cont.)

Pin No.	Pin name	DC voltage ( $V_{CC}=5V$ )	Equivalent circuit	Description
35	VASEL	5V		Video/audio mode-selection control for automatic tracking interface. Video mode is selected when this pin is high (open), and audio mode is selected when this pin is low.
36	SLOW SW	5V for playback		Still/slow mode selection control. Still mode is selected when this pin is high (open), and slow mode is selected when this pin is low, under the condition that Pin21 (PB CONT) is low.
36	Rec EQ	3.7V for recording		Recording equalization