



## LB1863M, 1869M

### Two-Phase Unipolar Brushless Motor Driver Automatic Recovery Type Circuit in a Miniature Flat Package

#### Overview

The LB1863M and LB1869 (LB1669M) are 2-phase unipolar brushless motor drivers that are provided in a miniature flat package that contributes to end product miniaturization and supports automatic mounting. These products support the implementation of motor drive lock protection and automatic recovery circuits, and alarm specifications with a minimal number of external components.

#### Features and Functions

- Hall elements can be connected directly to the IC itself.
- 1.5-A output current output transistors built in
- Rotation detection function that provides a low-level output during motor drive and a high-level output when the motor is stopped
- Motor lock protection and automatic recovery functions built in
- Thermal shutdown circuit
- Switching noise can be reduced with an external ceramic capacitor.

#### Classification

Package	MFP-10S	MFP-14S
System voltage		
12 V	LB1669M	LB1869M*
24 V		LB1863M*

Note: \* The LB1869M and LB1863M are pin compatible so that the same printed circuit board can be used for both 12 V and 24 V products.

#### Specifications

##### Absolute Maximum Ratings at Ta = 25°C

Parameter	Symbol	Conditions	Ratings	Unit
Maximum input current	$I_{CC \text{ max}}$	$t \leq 20 \text{ ms}$	200	mA
Output voltage	$V_{OUT}$	LB1863M	-0.3 to +85	V
		LB1869M	-0.3 to +60	V
Output current	$I_{OUT}$		1.5	A
RD influx current	$I_{RD}$		10	mA
RD voltage	$V_{RD}$		30	V
Allowable power dissipation	$P_d \text{ max}$	When mounted (on a $20 \times 15 \times 1.5\text{-mm}^3$ glass-epoxy printed circuit board)	800	mW
Operating temperature	$T_{opr}$		-30 to +80	°C
Storage temperature	$T_{stg}$		-55 to +150	°C

#### Package Dimensions

unit: mm

##### 3111-MFP14S

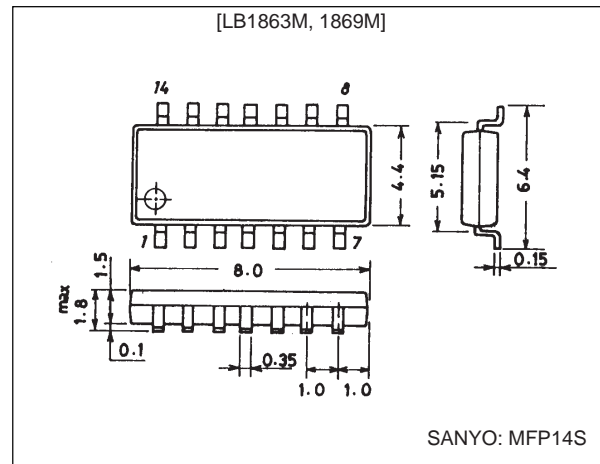

## LB1863M, 1869M

### Allowable Operating Ranges at $T_a = 25^\circ\text{C}$

Parameter	Symbol	Conditions	Ratings	Unit
Input current range	$I_{CC}$		6.0 to 50	mA
Common-mode input voltage range	$V_{ICM}$		0 to $V_{IN} - 1.5$	V

### Electrical Characteristics at $T_a = 25^\circ\text{C}$ , $I_{CC} = 10\text{ mA}$

Parameter	Symbol	Conditions	Ratings			Unit
			min	typ	max	
Output voltage 1	$V_{OR}$	LB1863M	80			V
		LB1869M	60			V
Output voltage 2	$V_{O(SUS)}$	LB1863M : $I_O = 0.1\text{ A}$	65			V
		LB1869M : $I_O = 0.1\text{ A}$	40			V
Output saturation voltage	$V_{O(sat)1}$	$I_O = 0.5\text{ A}$		0.95	1.2	V
	$V_{O(sat)2}$	$I_O = 1.0\text{ A}$		1.15	1.5	V
Input voltage	$V_{IN}$	$I_{CC} = 7.0\text{ mA}$	6.4	6.7	7.0	V
Amplifier input offset voltage	$V_{OFF}$		-7	0	7.0	mV
Amplifier input bias current	$I_{BA}$		-250			nA
RD output saturation voltage	$V_{RD(sat)}$	$I_{RD} = 5\text{ mA}$		0.1	0.3	V
Capacitor discharge current	$I_{C1}$		2.1	3	3.9	$\mu\text{A}$
	$I_{C2}$		0.31	0.44	0.59	$\mu\text{A}$
Comparator input threshold voltage	$V_{TH1}$		0.77	$0.8V_{IN}$	0.83	V
	$V_{TH2}$		0.42	$0.45V_{IN}$	0.48	V

### Pin Assignment

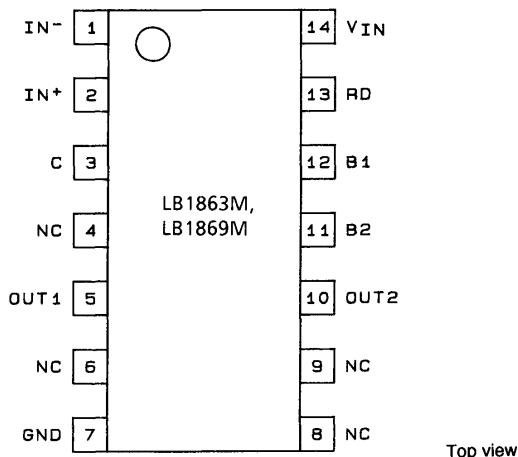

A02884

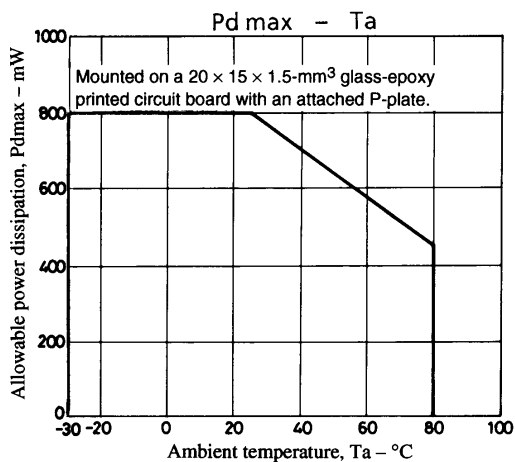

Equivalent Circuit, Block Diagram, and Sample Application

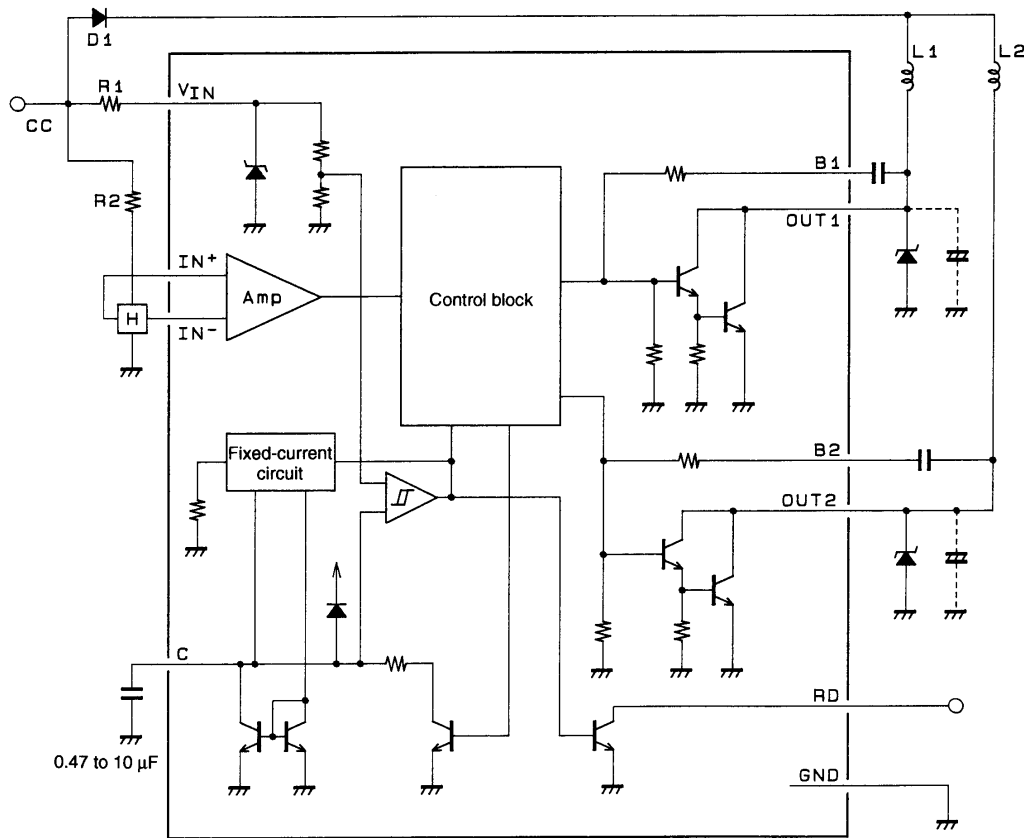

A02886

Sample Application Circuit

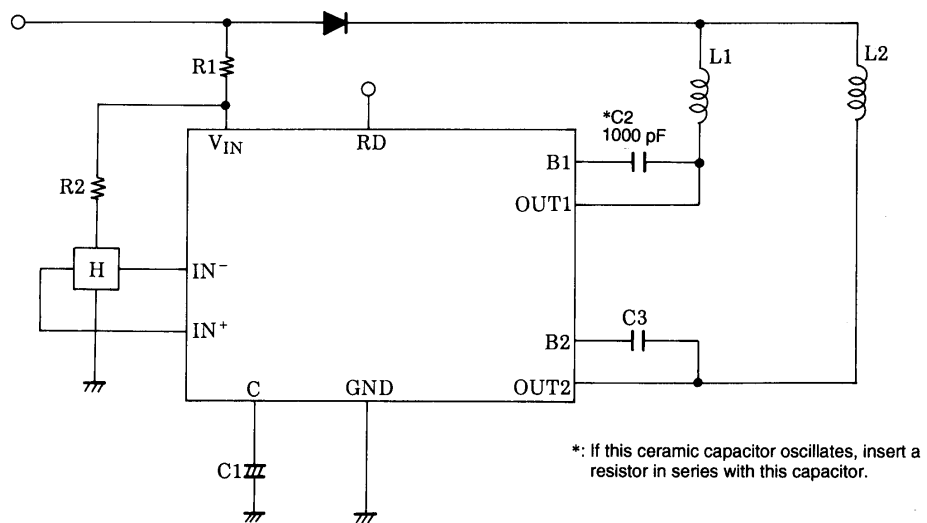

**Sample Application Circuit Output Waveforms**

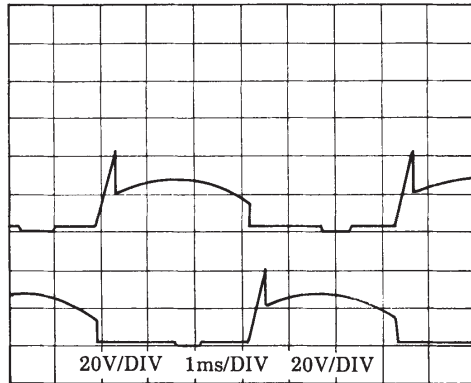

**Truth Table**

IN <sup>+</sup>	IN <sup>-</sup>	C	OUT1	OUT2	RD
H	L	L	H	L	L
L	H	L	L	H	L
H	L	H	H	H	H
L	H	H	H	H	H

**Design Documentation (See the application circuit diagram.)**

1. Power-supply voltage (V<sub>IN</sub> pin)

Since these miniature flat package products supply power to the Hall amplifier block and the control block from an internal parallel regulator, they operate with good stability with respect to kickback currents from the motor and variations in the power-supply voltage. They also provide an adequate ability to withstand surges. The resistor R1 between the V<sub>CC</sub> and V<sub>IN</sub> pins should be set up so that a current in the range I<sub>CC</sub> = 6 to 50 mA flows into the V<sub>IN</sub> pin in the fan motor power-supply voltage range.

V<sub>IN</sub> has a typical value of 6.7 volts when I<sub>CC</sub> is 7 mA. The current flowing into V<sub>IN</sub> can be calculated with the following formula.

$$I_{CC} = \frac{V_{CC} - V_{IN}}{R1} \dots\dots\dots(1)$$

• Abnormal voltage considerations

The maximum allowable current for the V<sub>IN</sub> pin is 200 mA. Therefore, the IC design allows it to withstand voltages up to the plus side abnormal voltage V<sub>surge</sub> give by formula (2).

$$V_{surge} = V_{IN} + R1 \times 200 \text{ mA} \dots\dots(2)$$

2. Hall input pin voltages (IN<sup>-</sup> and IN<sup>+</sup> pins)

The Hall element output voltages to the Hall element input pins must be in the range 0 to (V<sub>IN</sub> - 1.5 V). The gain from the Hall input pins to the output pin is over 100 dB. The Hall input amplifier offset voltage is ±7 mV. This means that the Hall element output must be set up taking this ±7 mV offset into account.

3. Output transistors (OUT1 and OUT2 pins)

- Output current: I<sub>O</sub> = 1.5 A maximum
- Output saturation voltage: V<sub>Osat</sub> = 1.15V/1.0 A (typical)

Applications should adopt one of the following three output protection techniques.

- ① If a capacitor is inserted between OUT and ground, use a capacitor with a value up to C = 10 μF, and design that value so that the kickback and reverse voltages do not exceed V<sub>OR</sub>.
- ② If a Zener diode is added, determine a value for the Zener voltage that is lower than V<sub>O(SUS)</sub>. If radio-frequency noise is a problem, insert a capacitor between B1 and B2.
- ③ If a capacitor is inserted between OUT and B1, set the capacitor value so that the kickback voltage is lower than V<sub>O(SUS)</sub>. If oscillation occurs, insert a resistor in series with the capacitor.

## 4. Output protection function (C pin)

This pin connects the capacitor that forms the automatic recovery circuit. If rotation stops due to, for example, a motor overload, the pin voltage rises and the output stops. The system automatically recovers from stopped to drive mode when the load is set to an appropriate level. The lock detection time can be set by changing the value of the capacitor.

For a 1- $\mu\text{F}$  capacitor: Lock detection time About 2 seconds  
 Lock protection time (output on) About 1 second  
 (output off) About 6 seconds

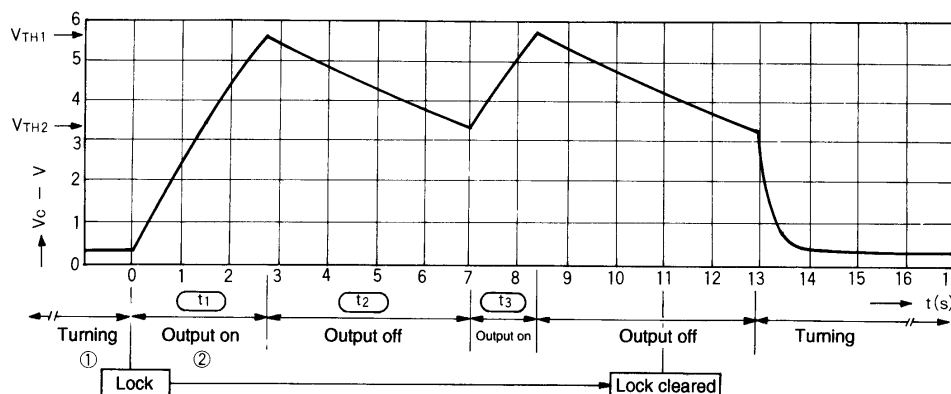

Automatic recovery circuit pin C voltage

- ① While the blades are turning, the capacitor is charged with a current of about  $3\ \mu\text{A}$  (typical), and C is discharged by pulses that correspond to the motor speed.
- ② When the blades lock, the capacitor is no longer discharged, and the voltage across the capacitor increases. The output is turned off when that voltage reaches  $0.8 \times V_{\text{IN}}$ .
- ③ When the output is turned off, the capacitor is discharged at a current of about  $0.44\ \mu\text{A}$  (typical). When the capacitor voltage falls under  $V_{\text{TH}2}$ , if the lock state is not yet cleared the capacitor continues discharging until  $V_{\text{TH}1}$ . (Note that the output is turned on at this time.) These operations, i.e. items ② and ③, are repeated with a ton:toff ratio of about 1:6 to protect the motor.
- ④ If the lock state has been cleared when the capacitor voltage reaches  $V_{\text{TH}2}$ , motor rotation is started by turning the output on.

## 5. Rotation detection signal (RD pin)

This is an open collector output, and outputs a low level in drive mode and a high level when the motor is stopped.

## 6. Radio-frequency noise reduction function (B1 and B2 pins)

These are base pins for Darlington pair outputs. Add capacitors of about 0.01 to 0.1  $\mu\text{F}$  if radio-frequency noise is a problem.

## 7. Thermal shutdown function

Turns off the output in response to coil shorting or IC overheating.

- No products described or contained herein are intended for use in surgical implants, life-support systems, aerospace equipment, nuclear power control systems, vehicles, disaster/crime-prevention equipment and the like, the failure of which may directly or indirectly cause injury, death or property loss.
- Anyone purchasing any products described or contained herein for an above-mentioned use shall:
  - ① Accept full responsibility and indemnify and defend SANYO ELECTRIC CO., LTD., its affiliates, subsidiaries and distributors and all their officers and employees, jointly and severally, against any and all claims and litigation and all damages, cost and expenses associated with such use:
  - ② Not impose any responsibility for any fault or negligence which may be cited in any such claim or litigation on SANYO ELECTRIC CO., LTD., its affiliates, subsidiaries and distributors or any of their officers and employees jointly or severally.
- Information (including circuit diagrams and circuit parameters) herein is for example only; it is not guaranteed for volume production. SANYO believes information herein is accurate and reliable, but no guarantees are made or implied regarding its use or any infringements of intellectual property rights or other rights of third parties.

This catalog provides information as of January, 1997. Specifications and information herein are subject to change without notice.