

**PSM DC-to-DC Controller**

**General Description**

The RT9568 is a DC-to-DC controller IC for step-down (Buck), step-up (Boost), inverting (Buck-Boost), and Flyback converters.

The device consists of an internal temperature compensated reference, comparator, controlled duty cycle oscillator with an active current limit circuit, driver, and high current output switch.

**Features**

- Pluse-Skipping Modulation
- Precision  $\pm 2\%$  Reference
- Operation from 3.0V to 30V Input
- Internal Switch Peak Current to 1.5A
- Design Flexibility
- Output Voltage Adjustable
- Current Limiting Adjustable
- Frequency Adjustable up to 200KHz

**Applications**

- DC-DC Converter Module

**Ordering Information**

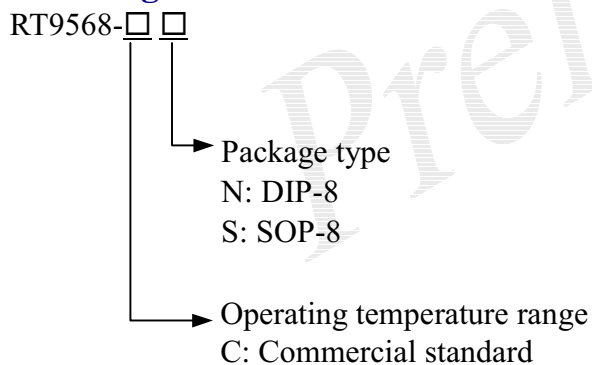

**Marking Information**

Part Number	Marking
RT9568CN	RT9568CN
RT9568CS	RT9568CS

**Pin Description**

Pin No.	Pin Name	Pin Function
1	SE	Emitter of Darlington transistor
2	OSC	Oscillator timing capacitor
3	GND	GND
4	FB	Feedback comparator inverting input
5	VCC	Power supply input
6	ICL	Current limit voltage input
7	DRI	Driver collector
8	SC	Collector of Darlington transistor

**Pin Configurations**

Part Number	Pin Configurations
RT9568CN (Plastic DIP-8)	
RT9568CS (Plastic SOP-8)	

**Absolute Maximum Ratings**

- Power Supply Voltage,  $V_{CC}$  ..... 30V
- Feedback Input Voltage Range ..... 0.3V to  $V_{CC}$
- Switch Collector Voltage,  $V_C(\text{switch})$  ..... 30V
- Switch Emitter Voltage( $V_{PIN8}=30V$ ),  $V_E(\text{switch})$  ..... 30V
- Switch Collector to Emitter Voltage,  $V_{CE}(\text{switch})$  ..... 30V
- Driver Collector Voltage,  $V_C(\text{driver})$  ..... 30V
- Driver Collector Current (see Note 1),  $I_C(\text{driver})$  ..... 100mA
- Switch Current,  $I_{SW}$  ..... 1.5A
- Power Dissipation and Thermal Characteristics:
  - DIP Plastic Package,  $P_D @ T_A=25^\circ C$  ..... 1.25W
  - Thermal Resistance,  $R_{\theta JA}$  .....  $100^\circ C/W$
  - SOP Plastic Package,  $P_D @ T_A=25^\circ C$  ..... 0.625W
  - Thermal Resistance,  $R_{\theta JA}$  .....  $160^\circ C/W$
- Operating Junction Temperature,  $T_J$  .....  $+150^\circ C$
- Storage Temperature Range,  $T_{STG}$  .....  $-60$  to  $+150^\circ C$

Note: 1. Maximum package power dissipation limits must be observed.

**Electrical Characteristics**

$V_{CC}=5.0V$ ,  $T_A = 25^\circ C$ , unless otherwise specified.

Parameter	Test Conditions	Min	Typ	Max	Units
Supply Current	$V_{CC} = 5.0V$ to $30V$ , $C_T = 1.0nF$ , Pin6 = $V_{CC}$ , $V_{pin4} > V_{ref}$ , Pin1 = GND, Remaining pins open	--	3.0	4.5	mA
Current Limit Sense Voltage	$I_{chg} = I_{dischg}$	280	330	380	mV
Charge Current	$5.0V \leq V_{CC} \leq 30V$	25	36	43	$\mu A$
Discharge Current	$5.0V \leq V_{CC} \leq 30V$	160	250	290	$\mu A$
Discharge to Charge Current Ratio	Pin6 to $V_{CC}$	5.5	6.9	7.9	--
Saturation Voltage, Darlington Connection	$I_{SW} = 1.0A$ , Pins 7, 8 connected	--	1.0	1.3	V
Saturation Voltage, Darlington Connection	$I_{SW} = 1.0A$ , $R_{PIN7} = 82\Omega$ to $V_{CC}$ , Forced $\beta \doteq 20$	--	0.5	0.7	V
DC Current Gain	$I_{SW} = 1.0A$ , $V_{CE} = 5.0V$	50	75	--	--
Collector Off-state Current	$V_{CE} = 30V$	--	0.01	100	$\mu A$
Reference Voltage	-	1.225	1.25	1.275	V
Reference Voltage Line Regulation	$3.0V \leq V_{CC} \leq 30V$	--	1.4	5.0	mV
Input Bias Current	$V_{in} = 0V$	--	-20	-400	nA

**Function Block Diagram**

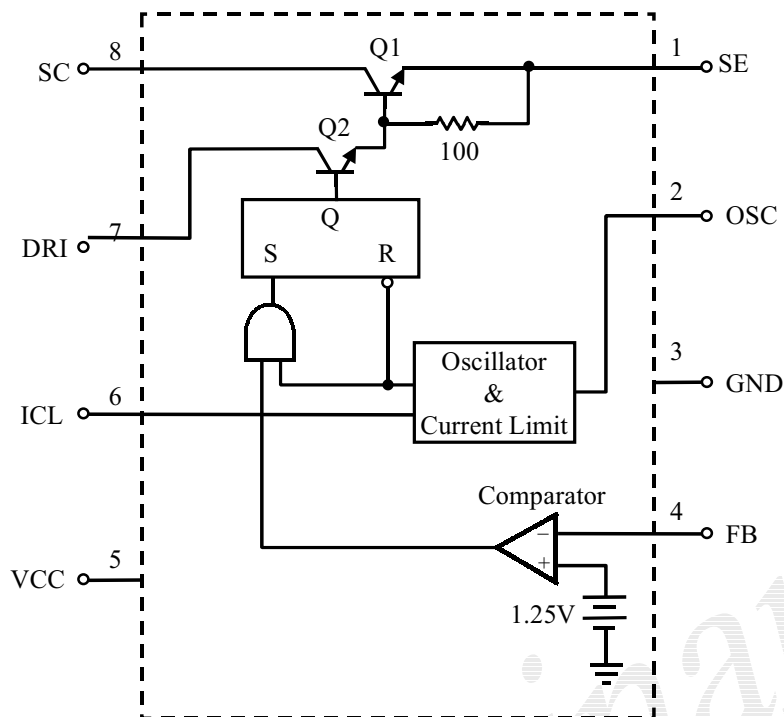

**Typical Application Circuit**

**Step-down Converter use Internal Switch**

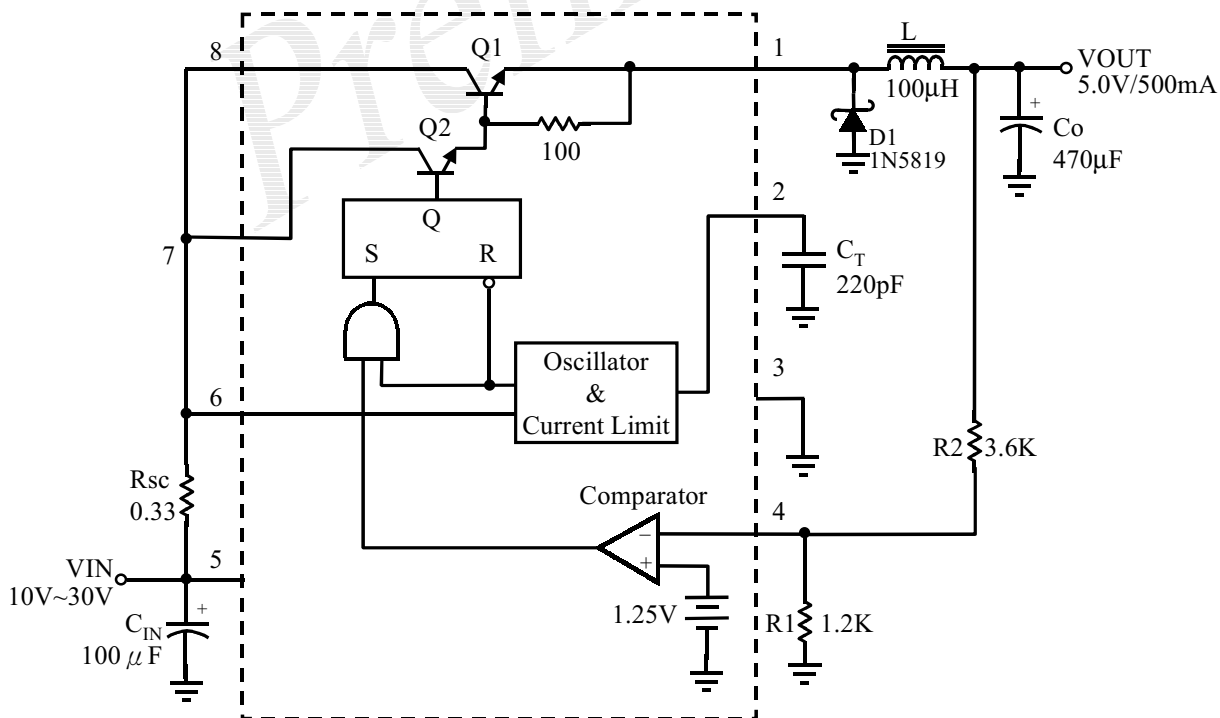

**Package Information**

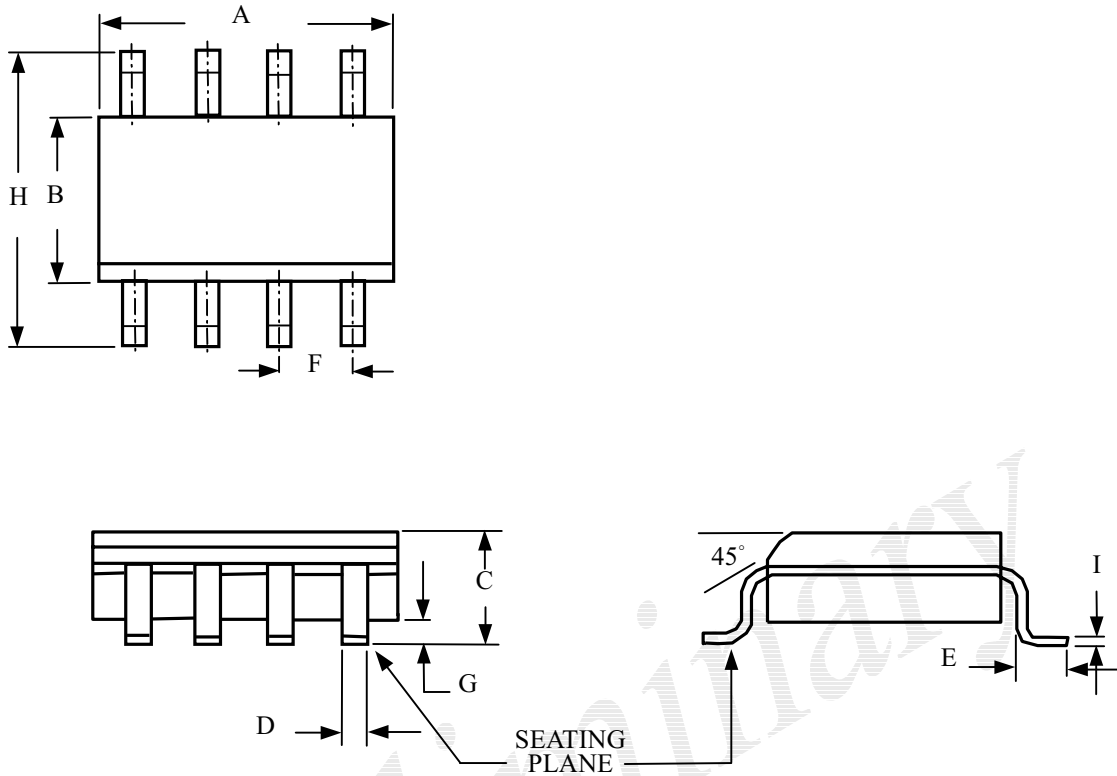

Symbols	Dimensions In Inches			Dimensions In Millimeter		
	Min	Norm	Max	Min	Norm	Max
A	0.185	0.191	0.197	4.70	4.85	5.00
B	0.150	0.153	0.157	3.80	3.90	4.00
C	0.054	0.061	0.068	1.35	1.55	1.75
D	0.012	0.016	0.020	0.30	0.40	0.50
E	0.016	--	0.050	0.40	--	1.27
F	--	0.050	--	--	1.27	--
G	0.004	0.006	0.009	0.10	0.17	0.25
H	0.229	0.237	0.244	5.80	6.00	6.20
I	0.007	0.008	0.009	0.18	0.22	0.25

**8-Lead SOP Plastic Package**

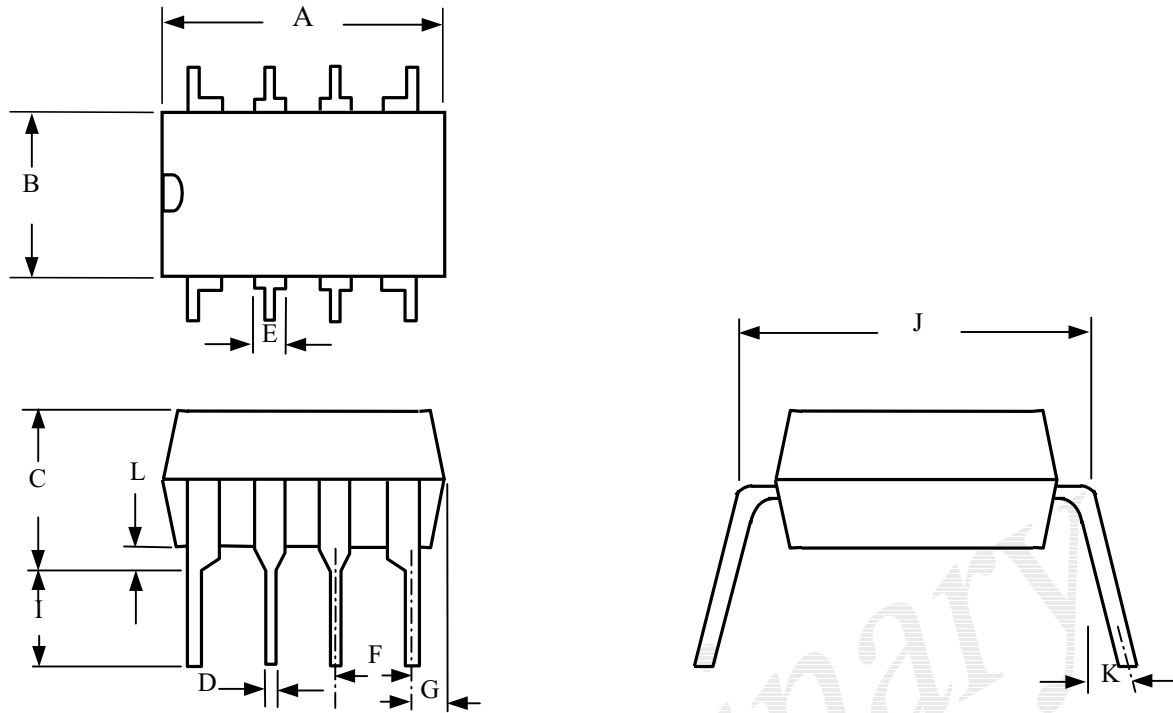

Symbols	Dimensions In Inches			Dimensions In Millimeter		
	Min	Norm	Max	Min	Norm	Max
A	0.357	0.362	0.367	9.00	9.30	9.60
B	0.244	0.254	0.264	6.20	6.45	6.70
C	--	--	0.180	--	--	4.57
D	0.016	0.018	0.020	0.35	0.45	0.55
E	0.040	0.055	0.070	1.02	1.40	1.78
F	--	0.100	--	--	2.54	--
G	--	0.035	0.050	--	0.89	1.27
I	0.120	0.130	0.140	3.05	3.30	3.55
J	0.290	0.300	0.310	7.60	8.00	8.40
K	--	--	15°	--	--	15°
L	0.015	0.025	0.035	0.39	0.64	0.89

**8-Lead DIP Plastic Package**