

## Microprocessor Supervisory Circuit with Pull Up Resistor

### FEATURES

- Holds Microcontroller in Reset
- Reset Microcontroller during power loss
- 4.375 Voltage Trip Point
- Active Low  $\overline{\text{RESET}}$  Pin
- Internal Pull-up Resistor
- Holds  $\overline{\text{RESET}}$  for 350ms (typical)
- $\overline{\text{RESET}}$  valid down to  $V_{\text{DD}} 1.0\text{V}$
- 45 $\mu\text{A}$  Typical Operating Current
- Offered in a 3 Pin SOT-23 Package

### APPLICATIONS

- Portable Electronic Devices
- Electrical Power Meter
- Computer System Board
- Modem

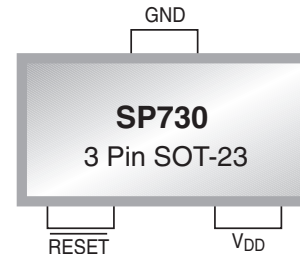

*Now Available in Lead Free Packaging*

### DESCRIPTION

The SP730 is a voltage supervisory device designed to keep a microcontroller in reset until the system voltage has reached the proper level and stabilized. It also operates as protection from brown-out conditions when the supply voltage drops below a safe operating level. The SP730 has an internal 5k pull-up resistor. The device has an active low  $\overline{\text{RESET}}$  pin and will assert the  $\overline{\text{RESET}}$  signal whenever the voltage on the  $V_{\text{DD}}$  pin is below the trip-point voltage. The part is available in a small 3 pin SOT-23 package. Contact factory for other trip voltage options.

### TYPICAL APPLICATION CIRCUIT

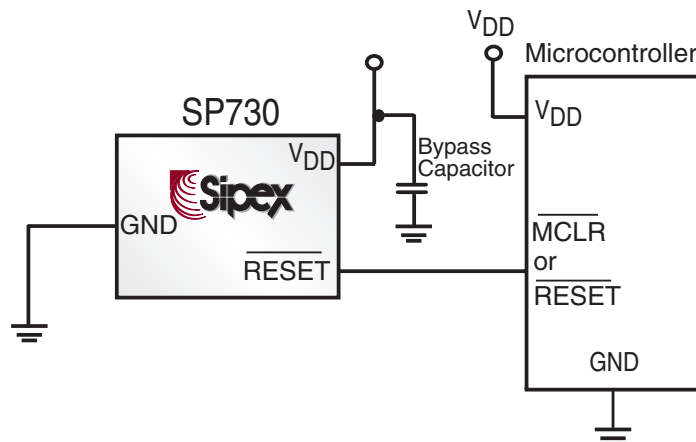

## ABSOLUTE MAXIMUM RATINGS

$V_{DD}$ .....	6.0V
All inputs and outputs w.r.t. GND .....	-0.6 to $V_{DD} + 1.0V$
Storage Temperature .....	-65°C to +150°C
Ambient Temperature with power applied.....	-65°C to +125°C
ESD Protection on all pins .....	$\geq 2kV$

These are stress ratings only and functional operation of the device at these ratings or any other above those indicated in the operation sections of the specifications below is not implied. Exposure to absolute maximum rating conditions for extended periods of time may affect reliability.

## ELECTRICAL CHARACTERISTICS

$V_{DD} = 1.0V - 5.5V$  ; -40°C to 85°C. The ♦ denotes the specifications which apply over the full operating temperature range, unless otherwise specified.

Parameter	Symbol	Min.	Typ.	Max.		Units	Conditions
Operating Voltage Range	$V_{DD}$	1.0		5.5	♦	V	
$V_{DD}$ Value to $\overline{\text{RESET}}$	$V_{DDMIN}$	1.0			♦	V	
Operating Current	$I_{DD}$		45	60	♦	$\mu A$	$V_{DD} = 5.5V$ (no load)
$V_{DD}$ Trip Point	$V_{TRIP}$	4.25	4.375	4.50	♦	V	
Threshold Hysteresis	$V_{HYS}$		50		♦	mV	
$\overline{\text{RESET}}$ Low Level Output Voltage	$V_{OL}$			0.6	♦	V	$I_{OL} = 8.5mA$ , $V_{DD} = V_{TRIP MIN}$
$\overline{\text{RESET}}$ High Level Output Voltage	$V_{OH}$	$V_{DD} - .7$			♦	V	$I_{OH} = 50\mu A$ , $V_{DD} > V_{TRIP MAX}$
Pull up Resistor			5		♦	K	
$V_{DD}$ Detect to $\overline{\text{RESET}}$ Inactive	$t_{RPU}$	150	350	700	♦	ms	
$V_{DD}$ Detect to $\overline{\text{RESET}}$	$t_{RPD}$		10		♦	$\mu S$	$V_{DD}$ ramped from $V_{TRIP MAX}$ ( $V_{TRIP MAX} + 250mV$ ) to ( $V_{TRIP MIN} - 250mV$ )

## FUNCTIONAL DIAGRAM

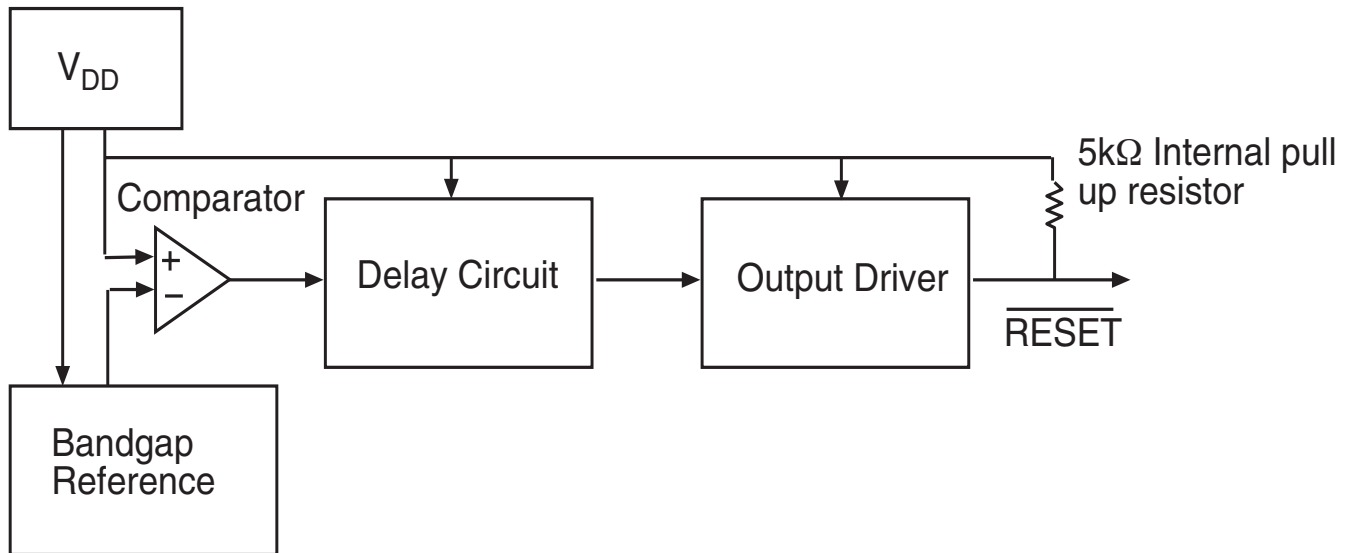

## TIMING DIAGRAM

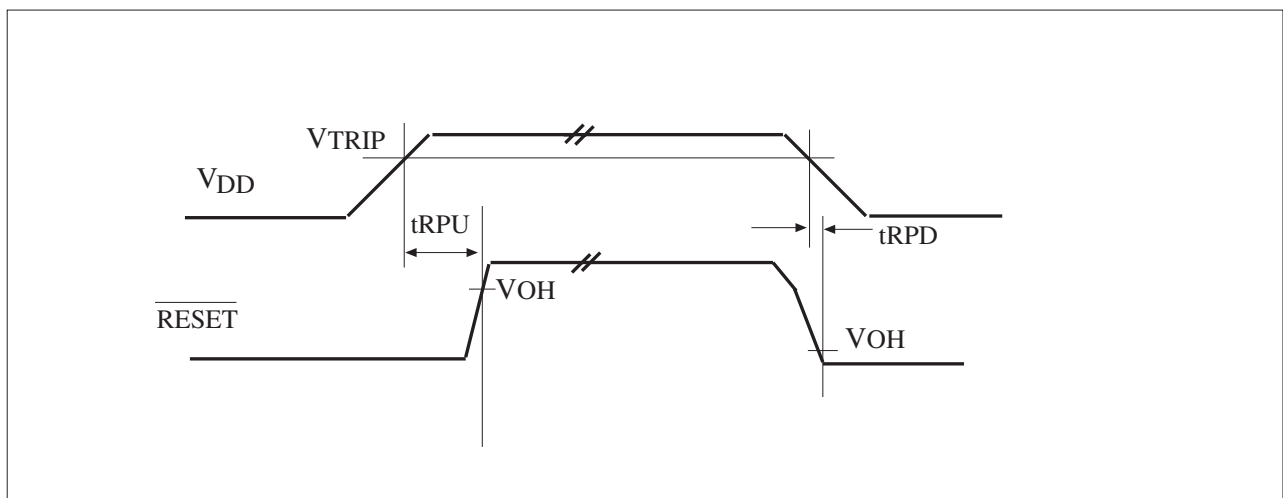

Figure 1: SP730 Timing Diagram

## PIN DESCRIPTION

PIN NUMBER	PIN NAME	3 PIN SOT-23 DESCRIPTION
1	$\overline{\text{RESET}}$	Active Low. This pin goes low whenever $V_{\text{DD}}$ falls below the reset threshold.
2	$V_{\text{DD}}$	Supply input.
3	GND	Ground.

# TYPICAL PERFORMANCE CHARACTERISTICS

### I<sub>dd</sub> vs Temperature

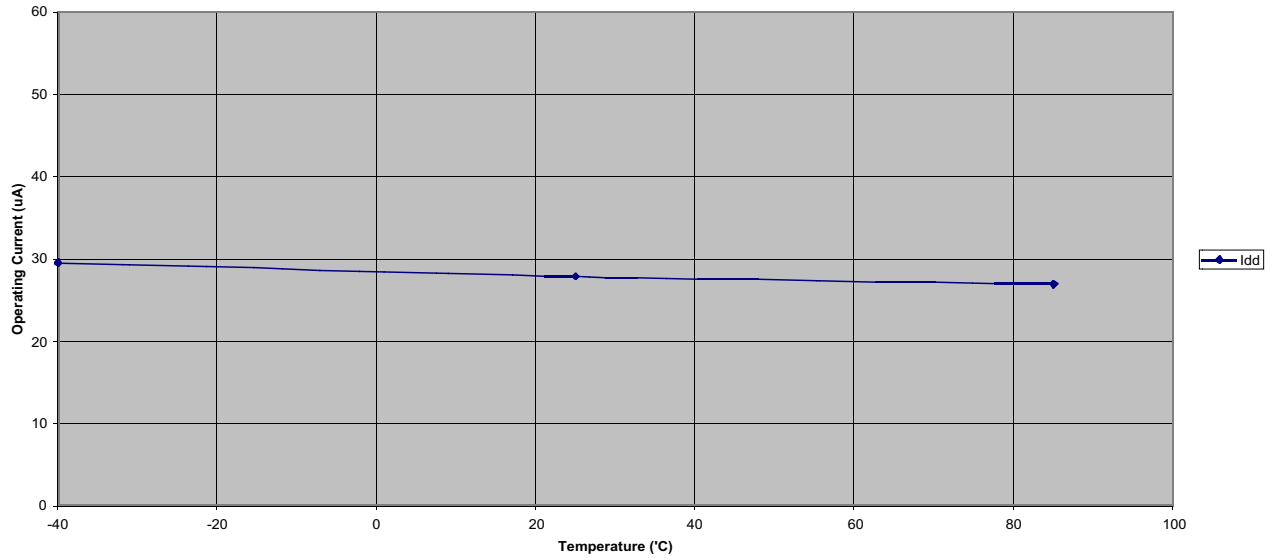

### tRPU vs Temperature

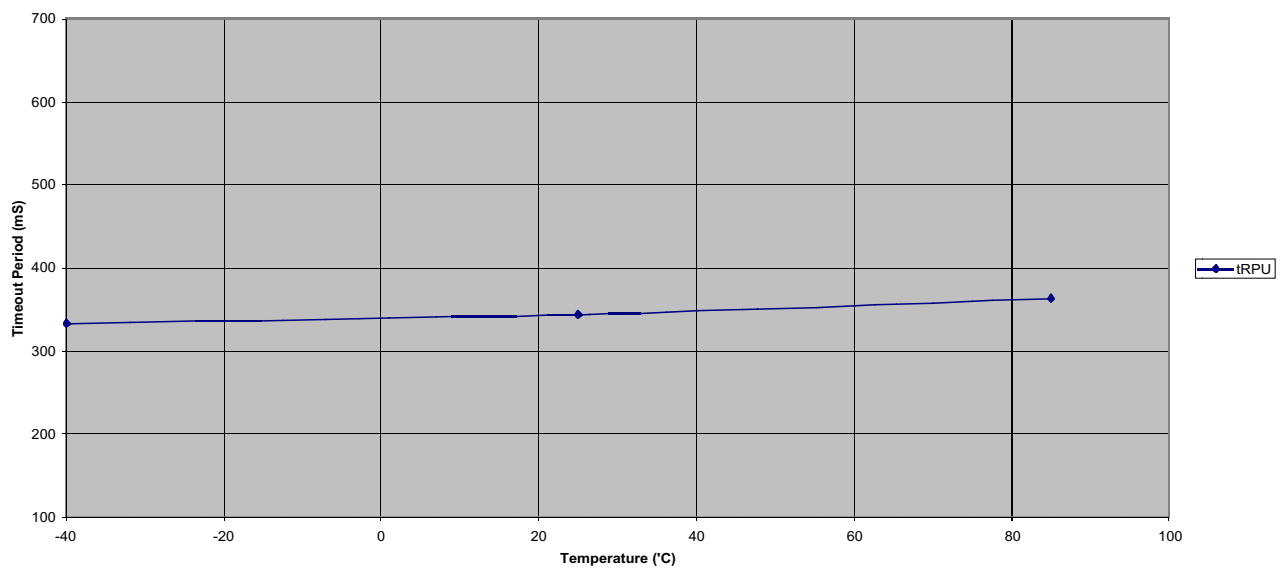

# TYPICAL PERFORMANCE CHARACTERISTICS

### Normalized VTRIP vs Temperature

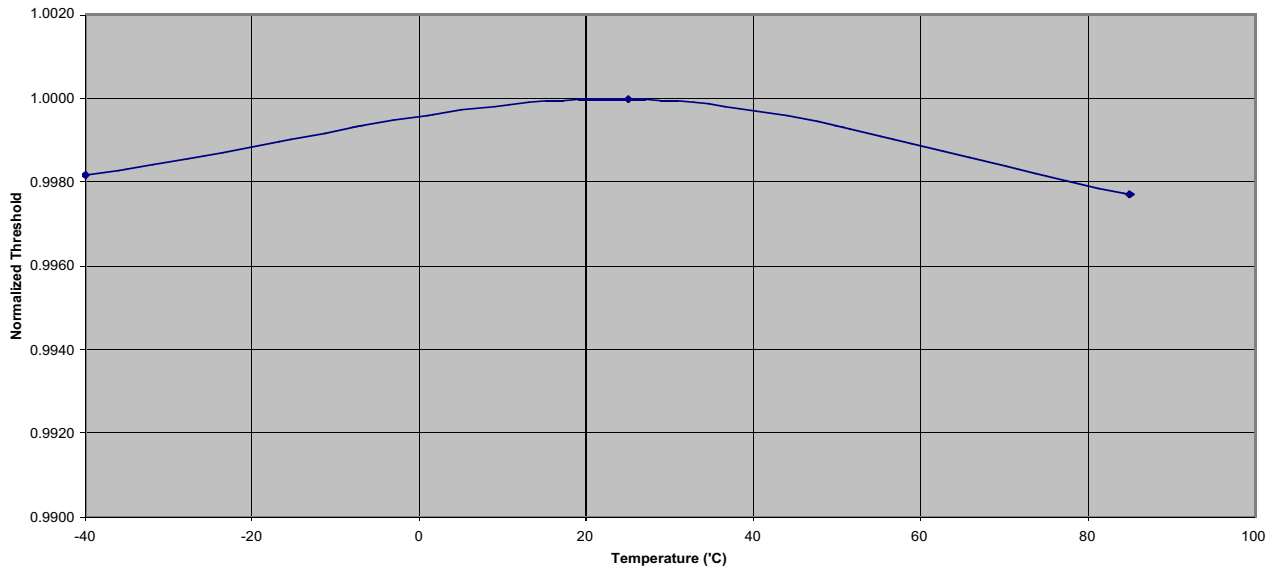

### VOL vs IOL

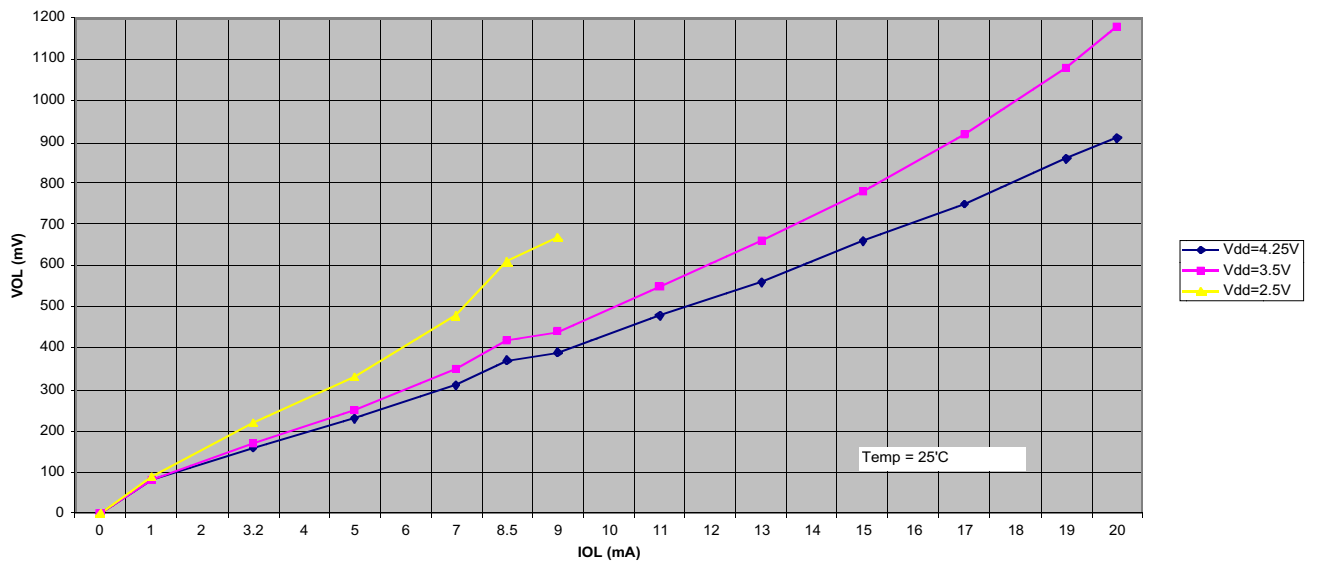

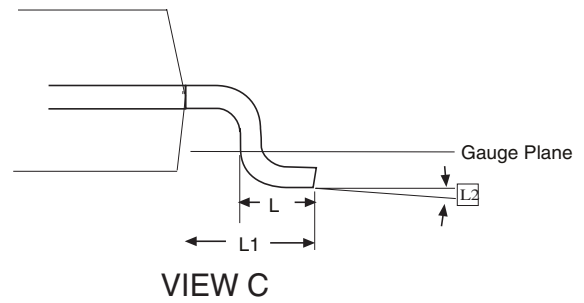
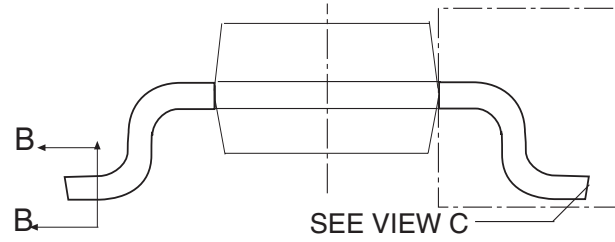
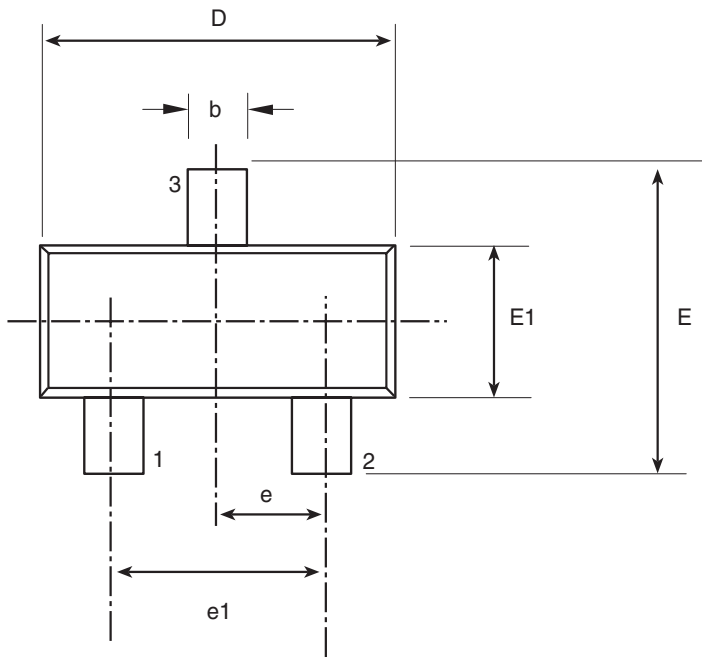

Dimensions in (mm)	3 PIN SOT-23 JEDEC TO-236 (AB) Variation		
	MIN	NOM	MAX
A	0.89	-	1.12
A1	0.01	-	0.10
A2	0.88	.95	1.02
b	0.30	-	0.50
c	0.08	-	0.20
D	2.80	2.90	3.04
E	2.10	-	2.64
E1	1.20	1.30	1.40
L	0.30	0.45	0.60
L1	0.54 REF		
Ø	0°	-	8°

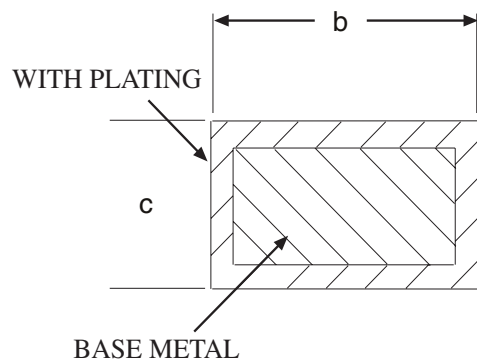
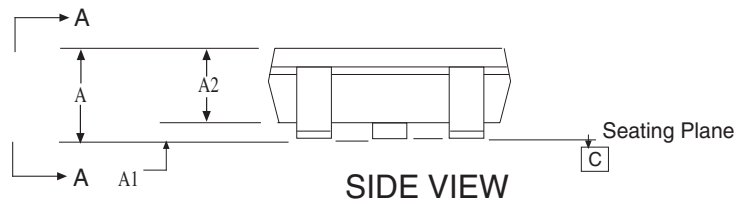

---

## ORDERING INFORMATION

Part number	Top Mark	Temperature	Package
SP730EK-4.375.....	V3WW.....	-40°-85°.....	3 Pin SOT-23
SP730EK-4.375/TR.....	V3WW.....	-40°-85°.....	3 Pin SOT-23

Contact factory for other trip voltage options.

Available in lead free packaging. To order add "-L" suffix to part number.

Example: SP730EK-4.375/TR = standard; SP730EK-4.375-L/TR = lead free

/TR = Tape and Reel

Pack quantity is 2500 for SOT-23.



ANALOG EXCELLENCE

**Sipex Corporation**

**Headquarters and  
Sales Office**  
233 South Hillview Drive  
Milpitas, CA 95035  
TEL: (408) 934-7500  
FAX: (408) 935-7600

Sipex Corporation reserves the right to make changes to any products described herein. Sipex does not assume any liability arising out of the application or use of any product or circuit described herein; neither does it convey any license under its patent rights nor the rights of others.