

## High Power LED Driver for Parallel Configuration

### FEATURES

- Drives up to 8 WLEDs
- Low Profile Inductorless Regulator
- 1x/1.5x Mode Charge Pump
- 200mA Output Using 1 $\mu$ F Ceramic Caps
- +2.7V to +5.5V Input Voltage Range
- 0.9mA Quiescent Current
- 1 $\mu$ A Shutdown Current
- Built-in 1.2MHz Oscillator
- Programmable Output Current or Voltage
- PWM Dimming Control via Enable Pin
- Shutdown to Disconnect Output from Input via Shutdown
- Soft Start to limit In-Rush Current
- Space Saving 10-pin 3 x 3mm DFN Package

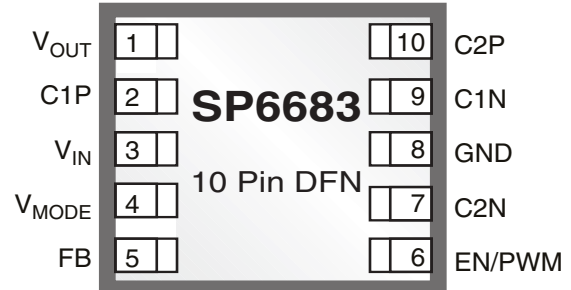

*Now Available in Lead Free Packaging*

### APPLICATIONS

- Mobile Phone
- PDA
- Digital Still Camera
- Digital Camcorder
- Palmtop Computer
- Color LCD Module

### DESCRIPTION

The SP6683 is a high power current regulated charge pump ideal for converting a Li-Ion battery input for driving up to 8 white LED's used in backlighting color displays. The SP6683 operates with an internal 1.2MHz clock, enabling the use of small external components. Output current can be accurately regulated by modulating the switcher between the charge pump and output capacitor. In shutdown mode, the SP6683 discharges the output to ground and draws less than 1 $\mu$ A current. The SP6683 utilizes 1 $\mu$ F capacitors to deliver up to 200mA current regulated WLED drive capability. The SP6683 is offered in 10-pin DFN or MSOP package.

### TYPICAL APPLICATION SCHEMATIC

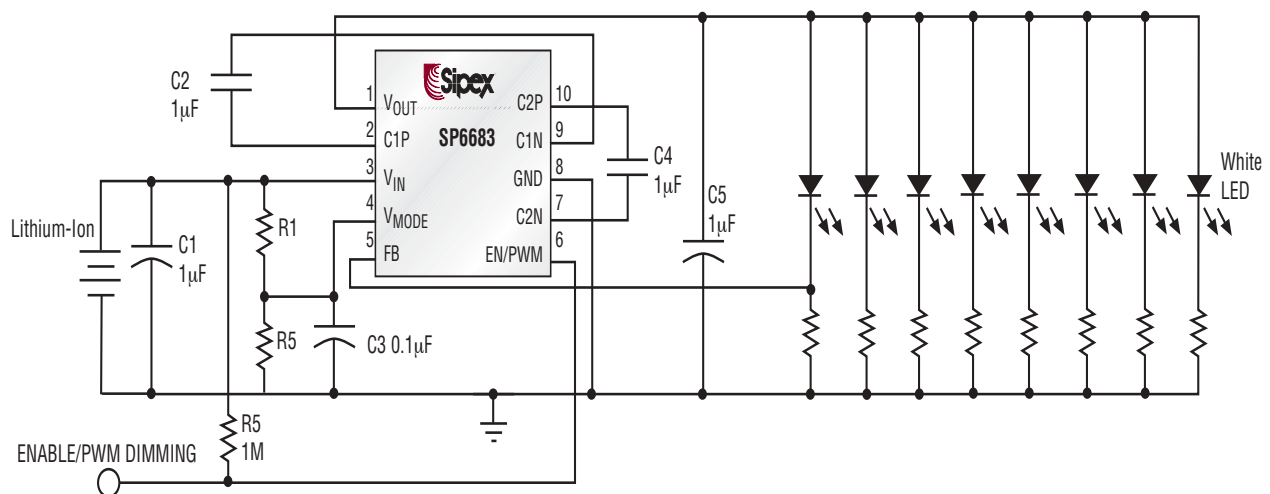

## ABSOLUTE MAXIMUM RATINGS

$V_{IN}$ , $V_{MODE}$ , $V_{OUT}$ and EN/PWM .....	-0.3V to 6V
$V_{IN} - V_{OUT}$ .....	0.7V
Output Current ( $I_{OUT}$ ) .....	300mA
Power Dissipation per Package - 10-pin MSOP (derate 8.84mW/°C above +70°C) .....	720mW
Junction Temperature .....	+125°C
Storage Temperature .....	-65°C to +150°C
ESD Rating .....	2kV HBM

These are stress ratings only and functional operation of the device at these ratings or any other above those indicated in the operation sections of the specifications below is not implied. Exposure to absolute maximum rating conditions for extended periods of time may affect reliability.

## ELECTRICAL CHARACTERISTICS

Unless otherwise specified:  $V_{IN} = +2.7V$  to  $+5.0V$ ,  $C1=C2=C4=C5=1.0\mu F$  (Ceramic,  $ESR=0.03\Omega$ ) and  $T_{AMB} = -40^\circ C$  to  $+85^\circ C$  unless otherwise noted.

PARAMETER	MIN	TYP	MAX	UNITS	CONDITIONS
Input Voltage	2.7		5.5	V	
Quiescent Current		0.9	3	mA	$V_{IN} = 4.2V$ , $V_{OUT} = 3.6V$ , $I_{OUT} = 100\mu A$
Shutdown Current		1.0	1.5	$\mu A$	$V_{EN/PWM} = 0V$ , $V_{IN} = 5.5V$
Maximum Load Current		280		mA	$V_{IN} = 4.2V$ , $V_{OUT} = 3.6V$
Oscillator Frequency	0.8	1.2	1.6	MHz	$V_{IN} = 3.6V$
$V_{FB}$ Reference Voltage	0.275	0.306	0.337	V	
Output Resistance		7.5		$\Omega$	1.5X Mode, 100mA Load
		5		$\Omega$	1.0X Mode, 100mA Load
$V_{MODE}$ Threshold Voltage	1.15	1.25	1.35	V	$V_{IN}$ Falling @ 25°C
$V_{MODE}$ Hysteresis		30		mV	$V_{IN} = 3.6V$ @ 25°C
$V_{MODE}$ Pin Current		0.01	0.5	$\mu A$	$V_{MODE} = 1.25V$
EN/PWM Logic Low			0.4	V	
EN/PWM Logic High	1.6			V	
EN/PWM Pin Current		0.01	0.5	$\mu A$	$V_{EN/PWM} = 4.2V$
FB Pin Current			0.5	$\mu A$	$V_{FB} = 1V$
$V_{OUT}$ Ripple		80		mV	$V_{IN} = 5V$ , $V_{OUT} = 4V$ , $I_{OUT} = 100mA$ , 1.5x Mode
$V_{OUT}$ Turn-On Time		175	500	$\mu s$	$V_{IN} = 3.6V$ , FB within 90% regulation

## PIN DESCRIPTION

PIN NUMBER	PIN NAME	DESCRIPTION
1	V <sub>OUT</sub>	Regulated charge pump output.
2	C1P	Positive terminal to the charge pump flying capacitor C2.
3	V <sub>IN</sub>	Input supply voltage.
4	V <sub>MODE</sub>	Charge pump mode program pin. When V <sub>MODE</sub> is greater than 1.25V, a X1 charge pump is used. Otherwise, charge pump switches to X1.5 mode. A voltage divider shown in typical application circuit programs the V <sub>IN</sub> threshold for charge pump mode switching.
5	FB	This is the feedback pin for output current or voltage regulation. The voltage of this pin is compared with an internal 306mV reference.
6	EN/PWM	Enable and PWM dimming control input. Pull this pin low to disconnect V <sub>OUT</sub> from V <sub>IN</sub> and shutdown the SP6683. V <sub>OUT</sub> is pulled to ground in shutdown.
7	C2N	Negative terminal to the charge pump flying capacitor, C4.
8	GND	Ground reference.
9	C1N	Negative terminal to the charge pump flying capacitor, C2.
10	C2P	Positive terminal to the charge pump flying capacitor C4.

## FUNCTIONAL DIAGRAM

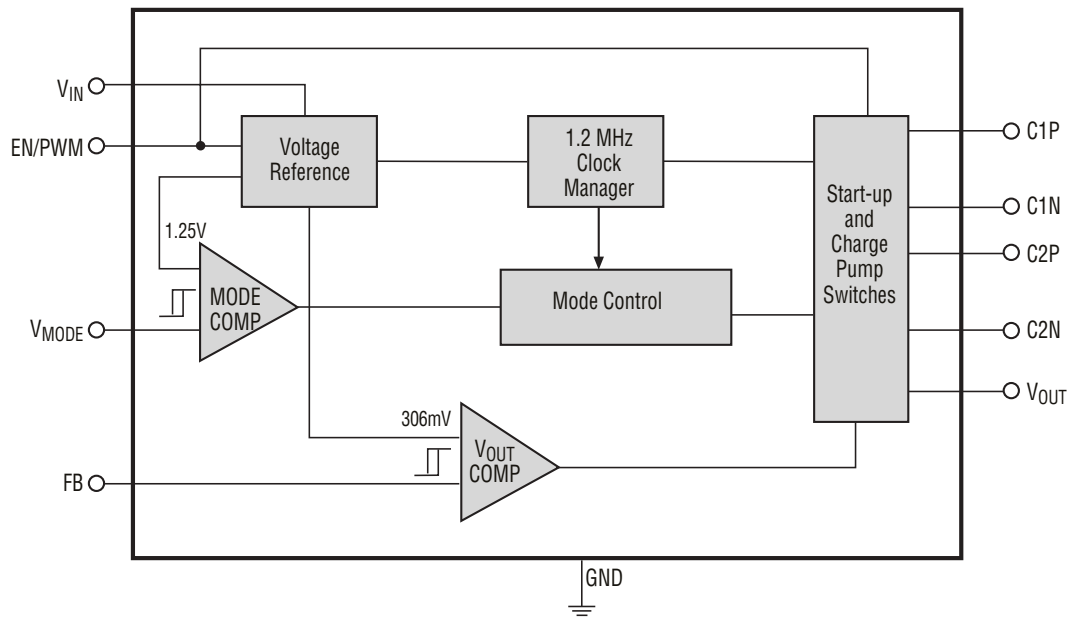

## General Overview

The SP6683 is a current regulated charge pump ideal for converting a Li-Ion battery input for driving white LEDs used in backlighting color displays in cellular phones, PDAs, digital cameras and MP3 players. The SP6683 is able to efficiently drive up to eight 20mA white LEDs in parallel and maintain a constant brightness over a very wide operating voltage range (2.7V to 5.5V). The SP6683 operates with an internal 1.2MHz clock, enabling the use of small external components. Other features of SP6683 include PWM dimming control as well as complete input/out disconnect in shutdown. In shutdown mode the IC draws less than 1.5µA current. The output regulation is achieved by sensing the voltage at the feedback pin and modulating the switch between the charge pump and output capacitor.

## Theory of Operation

The SP6683 regulated charge pump block diagram consists of four main blocks (Voltage Reference, Mode Control, Clock Manager, Start-up and Charge-Pump Switches) and two comparators ( $V_{MODE}$  Comparator and  $V_{OUT}$  Comparator).

**1) Voltage Reference.** This block provides the 306mV and 1.25V reference voltages needed for the two comparators.

**2) Mode Control.** An external voltage divider connected to the  $V_{MODE}$  pin will define an input voltage to the mode comparator which sets the logic state of the mode selection outputs to the X1 or X1.5 modes.  $V_{MODE}$  is compared to a 1.25V bandgap voltage. For example, if one makes a 158K/100K divider, the mode will change at  $2.58 \times 1.25 \text{ V} = 3.23\text{V}$ . A comparator-based cycle by cycle regulation ensures that no mode change occurs during cycles.

**3) Clock Manager.** An internal 1.2MHz clock is generated in this block. Depending on the mode control, the appropriate clock phasing is generated here and sent to the start-up and charge-pump switches block.

**4)  $V_{OUT}$  Comparator and Output Control.** A 306mV reference voltage is compared to feedback output voltage to control the  $V_{out}$  needed for the application. Output current is set by a bias resistor from FB pin to GND pin chosen by the relationship:

$$I_{OUT} = \frac{V_{FB}}{R_{FB}}$$

where  $V_{FB} = 306\text{mV}$ .

## Configuring the SP6683 as Voltage or Current Source

The white LED load configuration used by customers can be discrete white LEDs or a white LED module. Inside the white LED module, there may or may not be resistors in series with the white LEDs. According to the different application requirements, the SP6683 can be configured as either a voltage source or a current source to provide solutions for these different applications, as shown in [figure 9~12](#). [Figure 9](#) shows using the SP6683 to drive discrete white-LEDs as a current source.

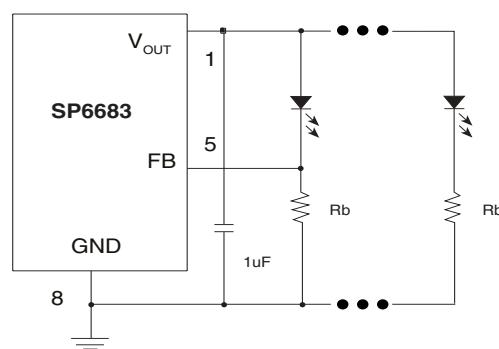

**Figure 9. Driving discrete white LEDs as current source**

The current in one white LED current is set by the ratio of the feedback pin voltage (306mV) and the bias resistor  $R_B$ . To set the operating current,  $R_B$  can be selected by:

$$R_B = \frac{V_{FB}}{I_{LED}}$$

The current of the remaining white LEDs is set according to the similarity of the white LEDs. 3-wire white LED module with internal series resistors as shown in [figure 10](#) can also be driven

in this way.

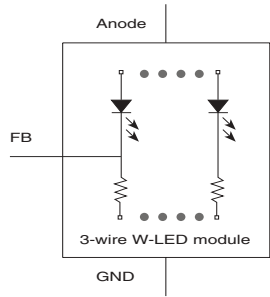

**Fig 10. 3-wire white LED module**

In figure 11, SP6683 was used to drive a 2-wire white LED module without internal series resistors as a current source. The bias resistor  $R_B$  is selected to regulate the total current of the white LED module instead of the current of single LED as in figure 9.

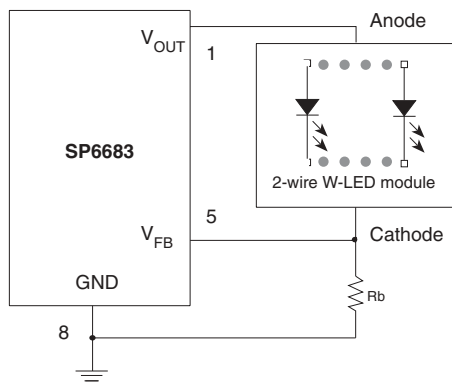

**Figure 11. Driving 2-wire white LED module as current source**

In this application, the bias resistor can be selected by:

$$R_B = \frac{V_{FB}}{I_{LED(TOTAL)}}$$

where  $I_{LED(TOTAL)}$  is the total operating current of all the white LEDs.

To use SP6683 as a voltage source for fixed voltage applications, a voltage divider is needed to program the output voltage, as shown in figure 12.

The output voltage is set by the ratio of the two resistors and the feedback control voltage as shown by:

$$V_{OUT} = \left(1 + \frac{R_5}{R_6}\right) \cdot V_{FB}$$

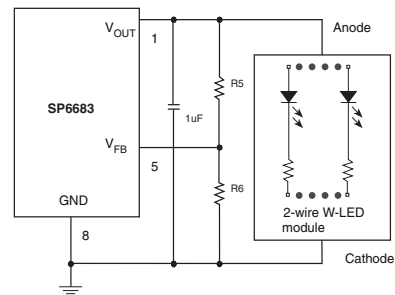

**Figure 12. Driving 2-wire white LED module as voltage source**

**PROGRAMMING THE OPERATING MODE**

SP6683 can automatically change from X1 mode to X1.5 mode for highest efficiency. To use this feature, divider resistors should be chosen according to the specific application, as shown in figure 13.

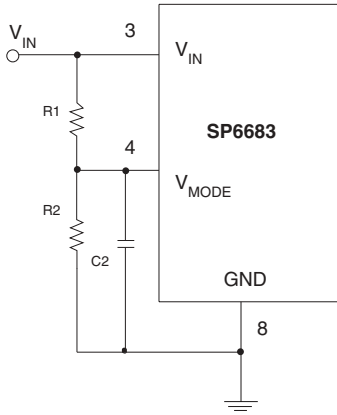

Figure 13. Programming the Vmode Resistors

The guideline for divider resistor selections is as follows. For high input voltage, the SP6683 will work in X1 mode. When the input voltage drops to Vth threshold voltage, it will switch to X1.5 mode automatically. The Vth threshold voltage for mode change can be calculated by:

$$V_{TH} = (V_F + 0.306 + m \cdot I_{LED} \cdot R_{OUT})$$

Where  $V_F$  and  $m$  are the forward voltage and number of the white LEDs,  $R_{out}$  is the output resistance of the SP6683.

The equation for the voltage divider  $R_1$  and  $R_2$  with  $V_{MODE} = 1.25V$  is:

$$V_{TH} = 1.25V \cdot (1 + R_1/R_2)$$

Table: 1

**SUGGESTED LOW ESR CAPACITORS**

MANUFACTURERS/ TELEPHONE#	PART NUMBER	CAPACITANCE/ VOLTAGE	CAPACITOR/ SIZE/TYPE	ESR AT 100kHz
TDK/847-803-6100	C2012X5R1A225K	2.2µF/10V	0805/X5R	0.030Ω
TDK/847-803-6100	C2012X5R0J475K	4.7µF/6.3V	0805/X5R	0.020Ω
MURATA/770-436-1300	GRM188R60J225KE01D	2.2µF/6.3V	0603/X5R	0.030Ω
MURATA/770-436-1300	GRM219R60J475KE01D	4.7µF/6.3V	0805/X5R	0.020Ω

Which can be expressed as  $R_1$ :

$$R_1 = V_{TH}/(1.25 - 1) \cdot R_2$$

For the typical SP6683 application, using  $V_F = 3.6V$ ,  $m = 8$ ,  $I_{LED} = 15mA$ ,  $R_{OUT} = 6\Omega$ ,  $V_{TH}$  will be 4.63V, Select  $R_2 = 100k\Omega$ , then  $R_1 = 270k\Omega$

**Capacitor Selection**

Ceramic capacitors are recommended for their inherently low ESR, which will help produce low peak to peak output ripple, and reduce high frequency spikes.

The fly capacitor controls the strength of the charge pump. Selection of the fly capacitor is a trade-off between the output voltage ripple and the output current capability. Decreasing the fly capacitor will reduce the output voltage ripple because less charge will be delivered to the output capacitor. However, smaller fly capacitor leads to larger output resistance, thus decreasing the output current capability and the circuit efficiency. Place all the capacitors as close to the SP6683 as possible for layout. Increasing the value of the input and output capacitors could further reduce the input and output ripple.

Refer to table 1 for some suggested low ESR capacitors.

## APPLICATION INFORMATION: Continued

### Brightness Control Using PWM

Dimming control can be achieved by applying a PWM control signal to the EN/PWM pin. The brightness of the white LEDs is controlled by increasing and decreasing the duty cycle of the PWM signal. While operating frequency range is from 60Hz to 700Hz, the recommended maximum brightness frequency range is from 60Hz to 200Hz. A repetition rate of at least 60Hz is required to prevent flicker.

### Brightness Matching

For white LEDs, the forward voltage drop is a function of the operating current. However, for a given current, the forward voltage drops do not always match due to normal manufacturing tolerance, thus causing uneven brightness of the white LEDs.

In [figure 14](#), assume high-precision bias resistors were used, the operating current ratio of two different branches can be easily derived as shown by:

$$\frac{I_1}{I_2} = \frac{V_{OUT} - V_{F1}}{V_{OUT} - V_{F2}}$$

where  $I_1$   $I_2$  are the operating current of the white

LEDs,  $V_{F1}$ ,  $V_{F2}$  are the forward voltage of the white LEDs.

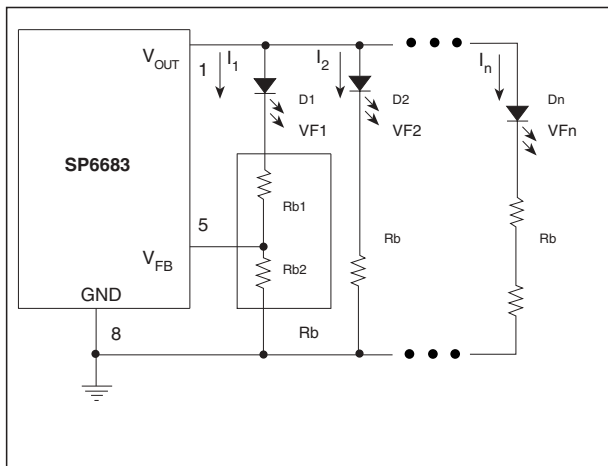

Figure 14. Increasing brightness matching

Since the brightness of the white LED is proportional to the operating current, for better brightness matching, a higher output voltage could be used. This could be done by using larger resistor, as shown in [figure 14](#).  $R_{b2}$  is used to bias the operating current of the white LED,  $R_{b1}$  is used to increase the output voltage. Better brightness matching was achieved at the cost of the power wasted on the bias resistor.

### Power Efficiency

The efficiency of driving the white LEDs can be calculated by

$$\eta = \frac{V_F \cdot I_F}{V_i \cdot I_i} = \frac{V_F \cdot I_F}{V_i \cdot (n \cdot I_F + I_Q)} \approx \frac{V_F}{V_i \cdot n}$$

Where  $V_i$ ,  $I_i$  are input voltage and current  $V_F$ ,  $I_F$  are the forward voltage and operating current of White LEDs  $I_Q$  is quiescent current, which is considered small compared with  $I_F$ .

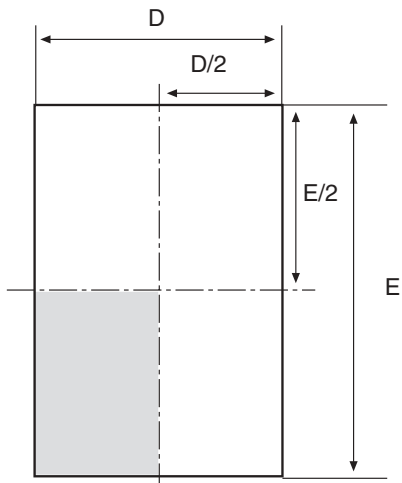

Top View

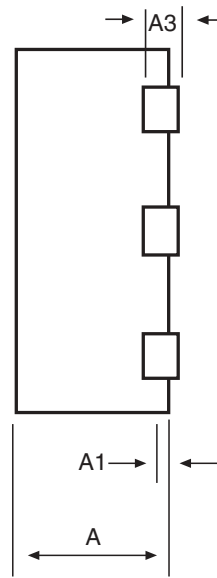

Side View

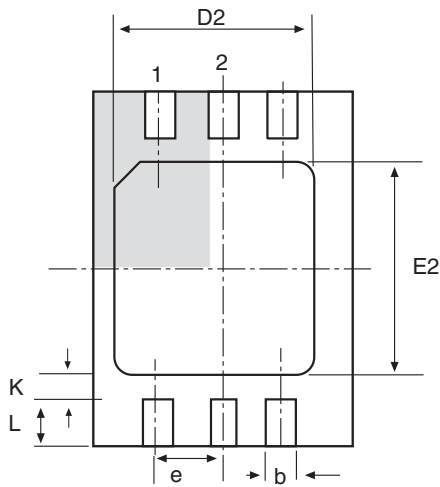

Bottom View

SYMBOL	DIMENSIONS in (mm)		
	MIN	NOM	MAX
A	0.80	0.90	1.00
A1	0	0.02	0.05
A3	0.20 REF		
b	0.18	0.25	0.30
D	3.00 BSC		
D2	2.20	-	2.70
e	0.50 PITCH		
E	3.00 BSC		
E2	1.40	-	1.75
K	0.20	-	-
L	0.30	0.40	0.50

## 10 Pin DFN



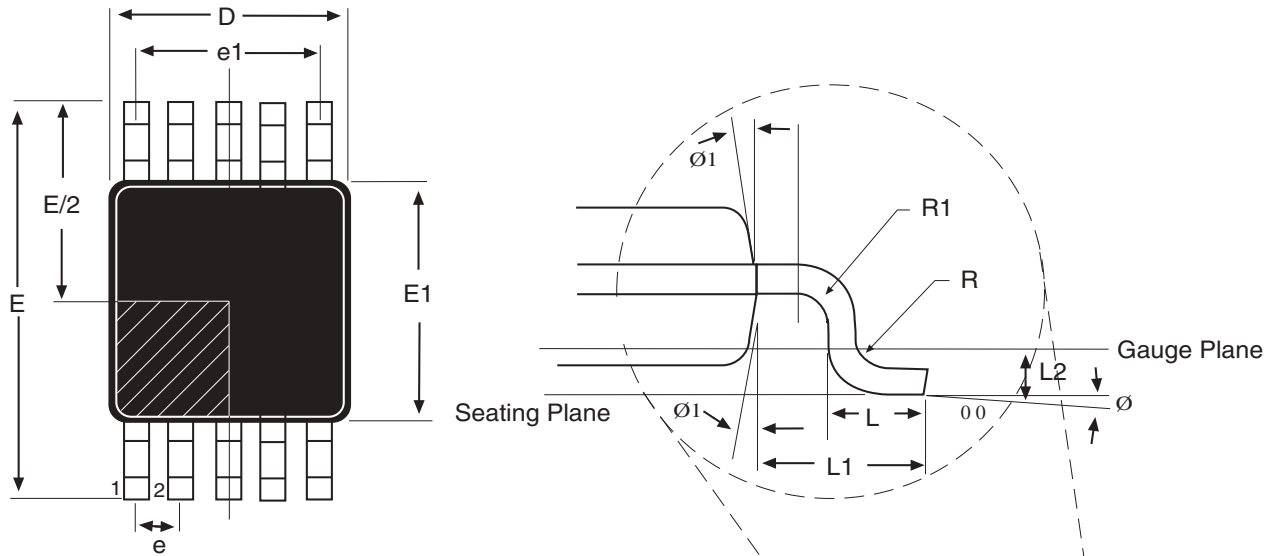

Pin #1 identifier must be indicated within this shaded area ( $D/2 * E1/2$ )

10-PIN MSOP JEDEC MO-187 (BA) Variation	Dimensions in (mm)		
	MIN	NOM	MAX
A	-	-	1.10
A1	0.00	-	0.15
A2	0.75	0.85	0.95
b	0.17	-	0.27
c	0.08	-	0.23
D	3.00 BSC		
E	4.90 BSC		
E1	3.00 BSC		
e	0.50 BSC		
e1	2.00 BSC		
L	0.4	0.60	0.80
L1	0.95 REF		
L2	0.25 BSC		
N	10		
R	0.07	-	-
R1	0.07	-	-
$\theta$	0°	-	8°
$\phi1$	5°	-	15°

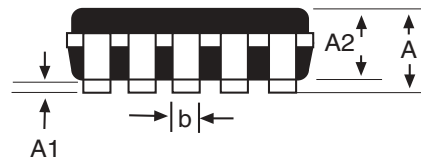
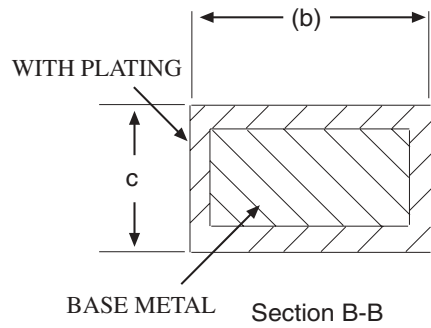

**10-PIN MSOP**

<b>Part Number</b>	<b>Operating Temperature Range</b>	<b>Package Type</b>
SP6683ER .....	-40°C to +85°C .....	10 Pin DFN
SP6683ER/TR .....	-40°C to +85°C .....	10 Pin DFN
SP6683EU .....	-40°C to +85°C .....	10 Pin MSOP
SP6683EU/TR .....	-40°C to +85°C .....	10 Pin MSOP

Available in lead free packaging. To order add "-L" suffix to part number.

Example: SP6683ER/TR = standard; SP6683ER-L/TR = lead free

/TR = Tape and Reel

Pack quantity is 3000 for DFN.



ANALOG EXCELLENCE

**Sipex Corporation**

**Headquarters and  
Sales Office**

233 South Hillview Drive  
Milpitas, CA 95035  
TEL: (408) 934-7500  
FAX: (408) 935-7600

Sipex Corporation reserves the right to make changes to any products described herein. Sipex does not assume any liability arising out of the application or use of any product or circuit described herein; neither does it convey any license under its patent rights nor the rights of others.