

Precision Adjustable Shunt Regulator

FEATURES

- **Wide Operating Current.....1mA to 150mA**
- **Extended Temperature Range..... 105°C**
- Low Temperature Coefficient 30 ppm/°C
- **Offered in TO-92, SOT-89 & SOT-23-5 Packages**
- **Improved** Replacement in Performance for TL431
- **Low Cost Solution**

APPLICATIONS

- Battery Operating Equipments
- Adjustable Supplies
- Switching Power Supplies
- Error Amplifiers
- Single Supply Amplifier
- Monitors / VCR / TV
- Personal Computers

PRODUCT DESCRIPTION

The SPX431C is a 3-Terminal Adjustable Shunt Voltage Regulator providing a highly accurate bandgap reference. SPX431C acts as an open-loop error amplifier with a 2.5V temperature compensation reference. The SPX431C thermal stability, wide operating current (150mA) and temperature range (105°C) makes it suitable for all variety of applications that are looking for a low cost solution with high performance.

The output voltage may be adjusted to any value between V_{REF} and 36V with 2 external resistors. The SPX431C is operating in full industrial temperature range of 0°C to 105°C. The SPX431C is available in TO-92, SOT-23-5 and SOT-89 packages.

PIN CONFIGURATION

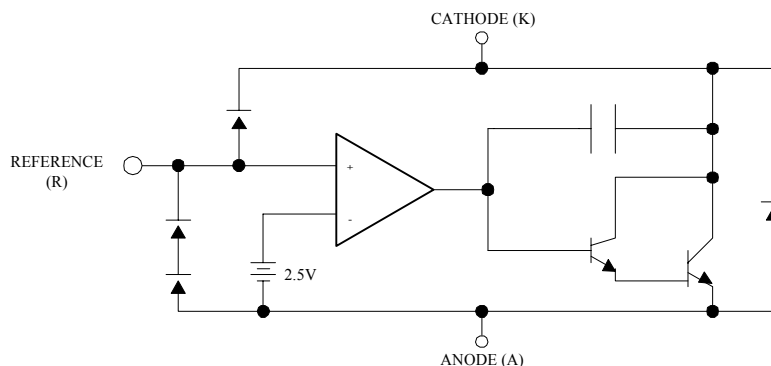
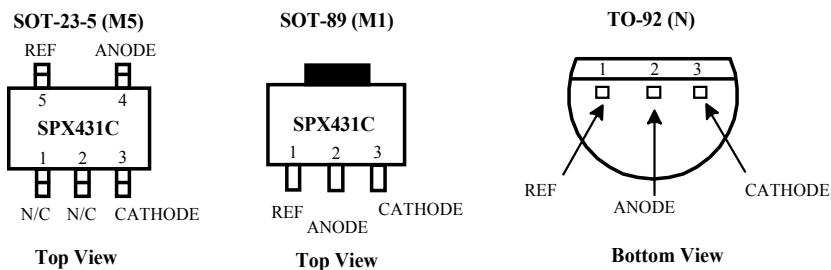

ABSOLUTE MAXIMUM RATINGS

Parameter	Symbol	Rating	Units
Cathode-Anode Reverse Breakdown	V_{KA}	37	V
Anode-Cathode Forward Current	I_{AK}	1	A
Operating Cathode Current	I_{KA}	150	mA
Reference Input Current	I_{REF}	10	mA
Continuous Power Dissipation at 25°C	P_D		
TO-92		775	mW
SOT-23		200	mW
SOT-89		1000	mW
Junction Temperature	T_J	150	°C
Storage Temperature	T_{STG}	- 65 to +150	°C
Lead Temperature (Soldering 10 sec.)	T_L	30	°C

Stresses greater than those listed under ABSOLUTE MAXIMUM RATINGS may cause permanent damage to the device. This is a stress rating only and functional operation of the device at these or any other conditions above those indicated in the operational sections of this specification is not implied. Exposure to absolute maximum rating conditions for extended periods may affect reliability.

RECOMMENDED CONDITIONS

Parameter	Symbol	Rating	Unit
Cathode Voltage	V_{KA}	V_{REF} to 20	V
Cathode Current	I_K	10	mA

TYPICAL THERMAL RESISTANCE

Package Type	θ_{JA}	θ_{JC}	Typical Derating
TO-92	160°C/W	80°C/W	6.3 mW/°C
SOT-23	575°C/W	150°C/W	1.7 mW/°C
SOT-89	110°C/W	8°C/W	9.1 mW/°C

ELECTRICAL CHARACTERISTICS at 25°C $I_K @ 10mA$ $V_K = V_{ref}$, unless otherwise specified.

Parameter	Symbol	Test Conditions	SPX431C			Unit
			Min	Typ	Max	
Reference Voltage	V_{REF}	$T_A = 25^\circ C$ TC = 1	2.445	2.495	2.545	V
Ratio of Change in V_{REF} to Cathode Voltage	$\frac{\Delta V_{REF}}{\Delta V_K}$	V_{REF} to 10V 10V to 36V TC = 2	-2.7 -2	-1.0 -0.4	0.3	mV/V
Reference Input Current	I_{REF}	TC = 2		0.7	4	μA
I_{REF} Temp Deviation	ΔI_{REF}	Over Temp. TC = 2		0.4	1.2	μA
Min I_K for Regulation	$I_{K(MIN)}$	TC = 1		0.4	1	mA
Off State Leakage	$I_{K(OFF)}$	$V_{REF} = 0V$, $V_{KA} = 36V$ TC=3		0.04	1	μA
Dynamic Output Impedance	Z_{KA}	TC = 1		0.15	0.5	Ω

TC = Test Circuit

*CALCULATING AVERAGE TEMPERATURE COEFFICIENT (TC)

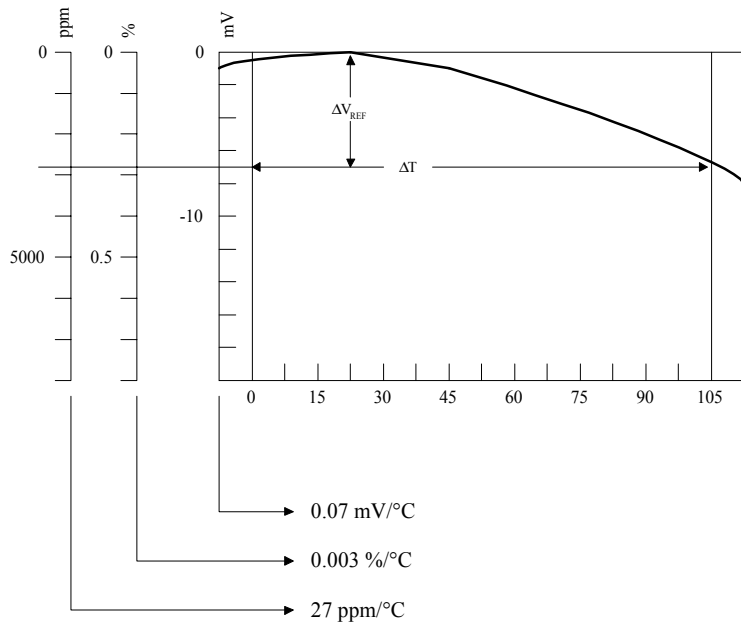

- TC in mV/°C = $\frac{\Delta V_{REF} \text{ (mV)}}{\Delta T_A}$
- TC in mV/°C = $\frac{\left(\frac{\Delta V_{REF}}{\Delta V_{REF} \text{ at } 25^\circ\text{C}}\right) \times 100}{\Delta T_A}$
- TC in ppm/°C = $\frac{\left(\frac{\Delta V_{REF}}{\Delta V_{REF} \text{ at } 25^\circ\text{C}}\right) \times 10^6}{\Delta T_A}$

TEST CIRCUITS

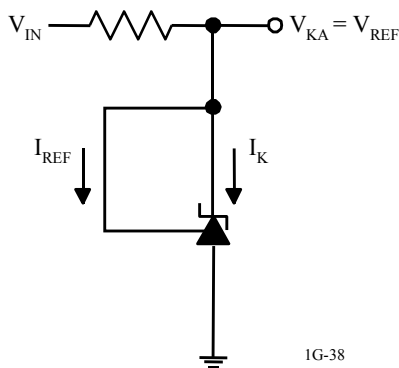

TEST CIRCUIT
For $V_{KA} = V_{REF}$

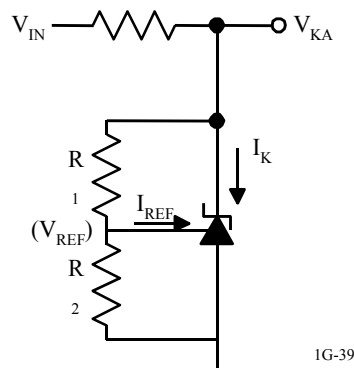

TEST CIRCUIT
For $V_{KA} > V_{REF}$

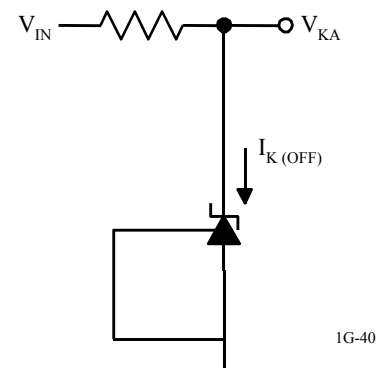

TEST CIRCUIT
For $I_{K(OFF)}$

TYPICAL PERFORMANCE CURVES

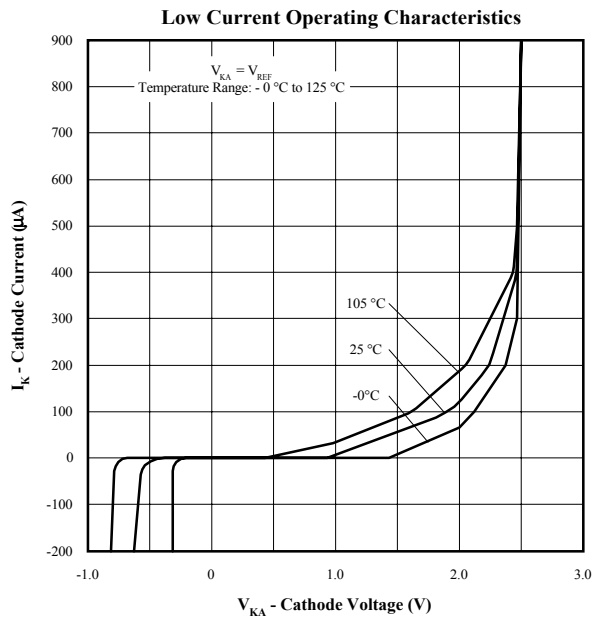

Figure 2

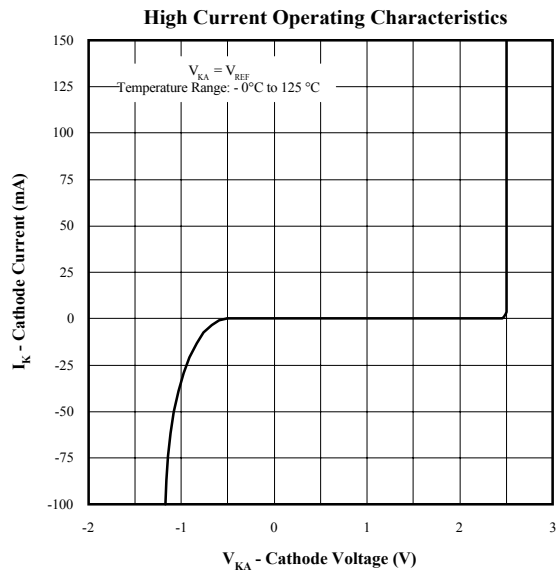

Figure 3

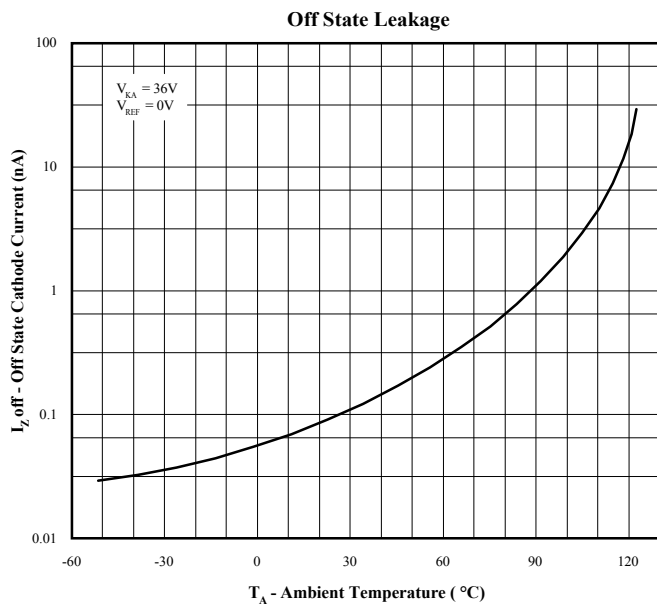

Figure 4

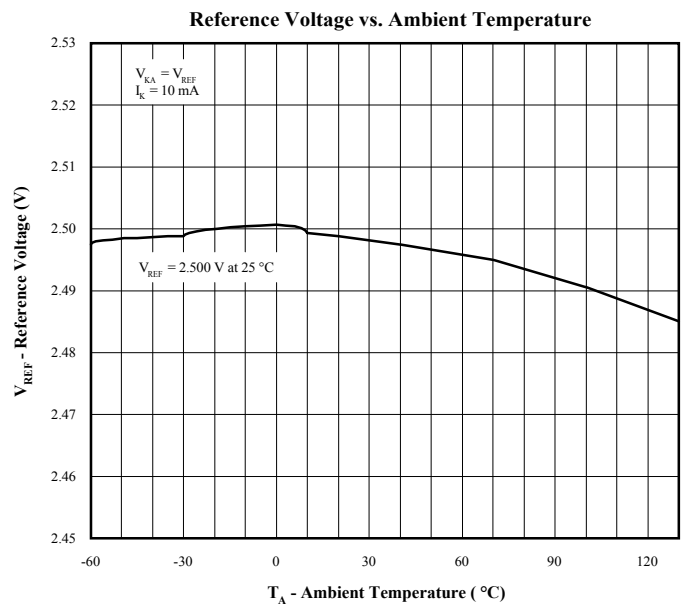

Figure 5

TYPICAL PERFORMANCE CURVES

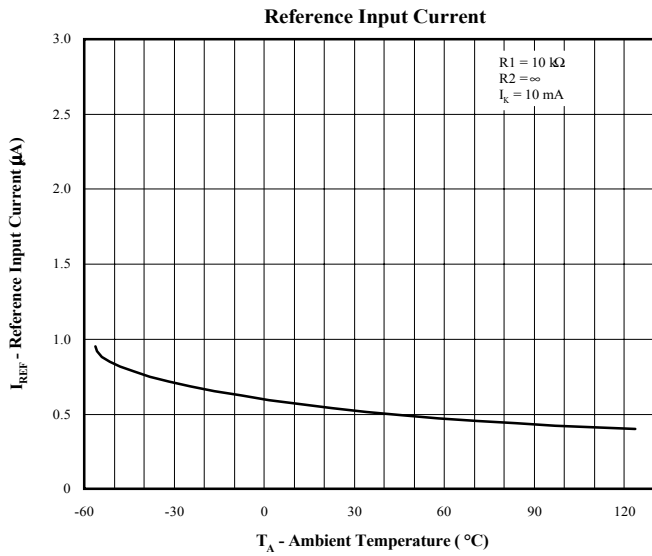

Figure 6

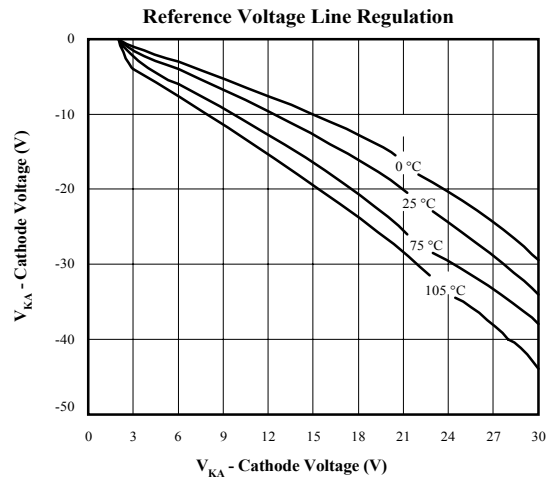

Figure 7

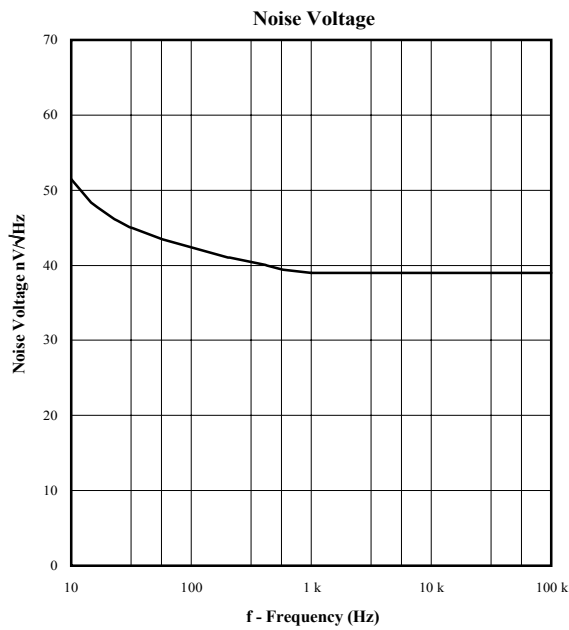

Figure 8

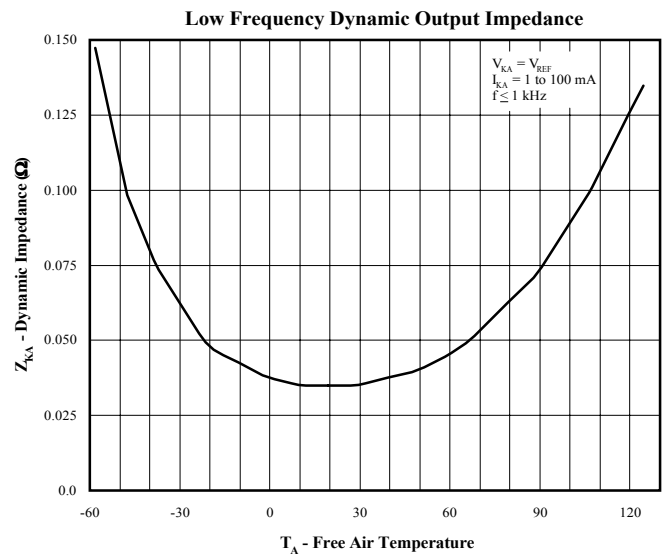
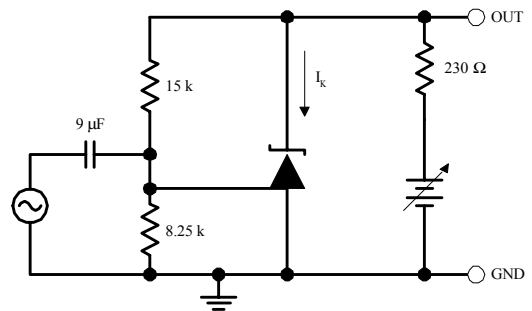
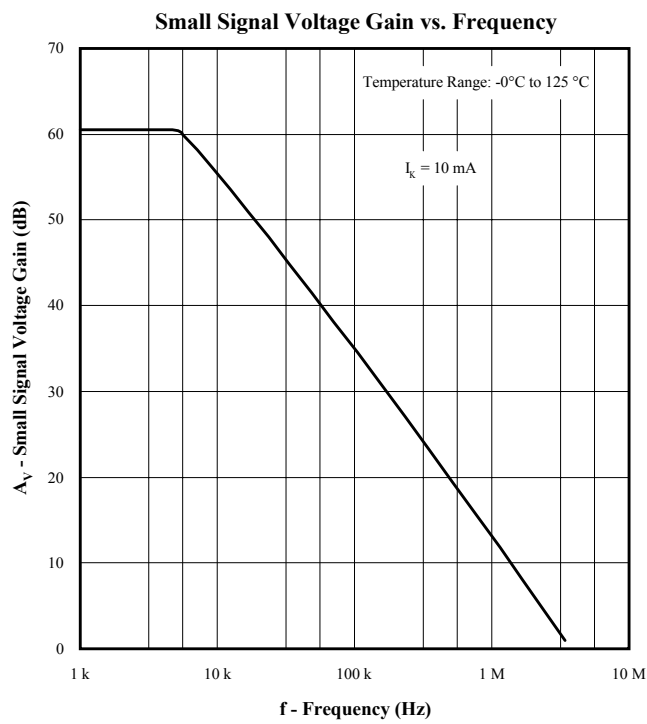
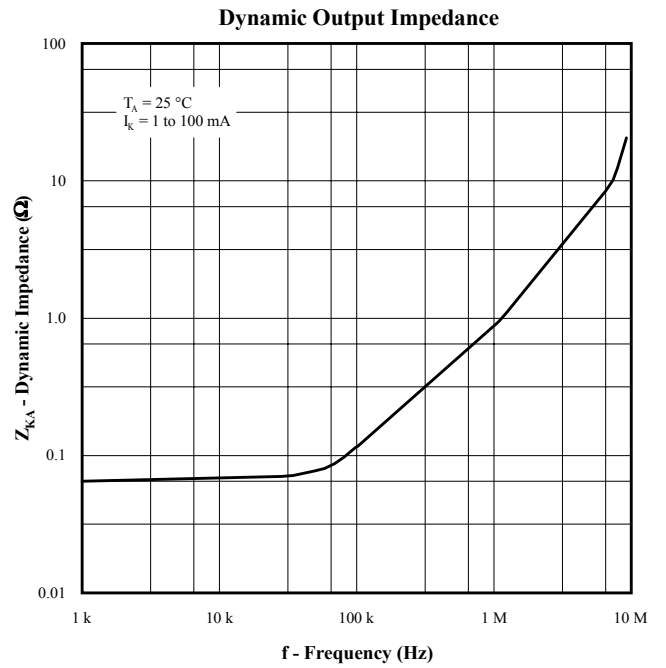

Figure 9

TYPICAL PERFORMANCE CURVES



TYPICAL PERFORMANCE CURVES

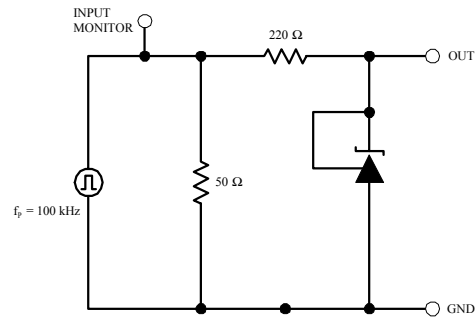
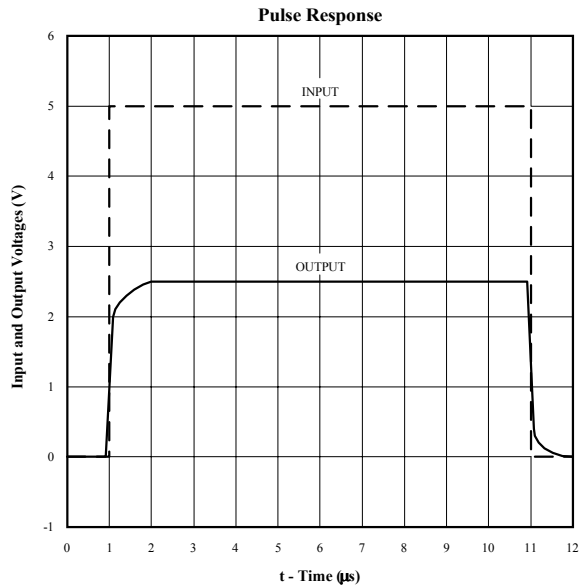

Figure 12

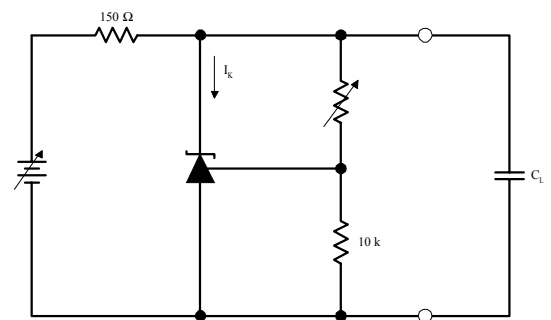
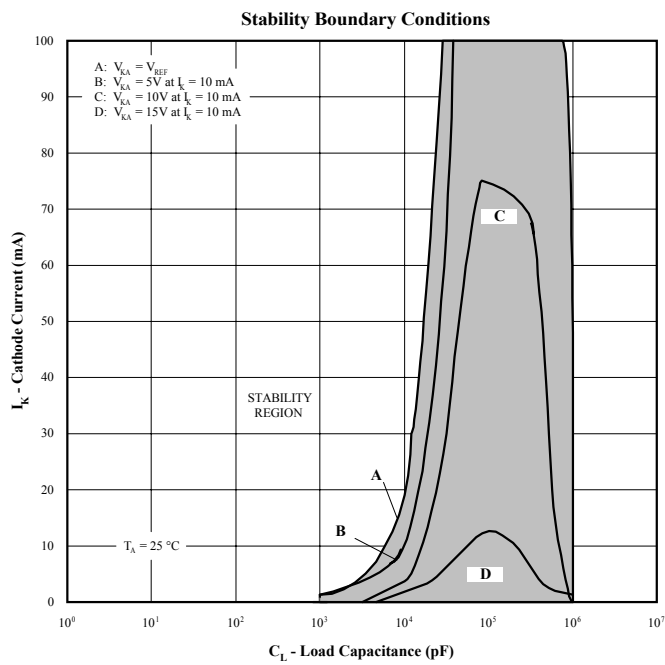

Figure 13

ORDERING INFORMATION

Ordering No.	Precision	Output Voltage	Packages
SPX431CM5	2%	2.5V	5 Lead SOT-23
SPX431CM1	2%	2.5V	3 Lead SOT-89
SPX431CN	2%	2.5V	3 Lead TO-92



SIGNAL PROCESSING EXCELLENCE

Sipex Corporation

Headquarters and Main Offices:

22 Linnell Circle
Billerica, MA 01821
TEL: (978) 667-8700
FAX: (978) 670-9001
e-mail: sales@sipex.com

233 South Hillview Drive
Milpitas, CA 95035
TEL: (408) 935-7600
FAX: (408) 934-7500

Sipex Corporation reserves the right to make changes to any products described herein. Sipex does not assume any liability arising out of the application or use of any product or circuit described hereing; neither does it convey any license under its patent rights nor the rights of others.

