

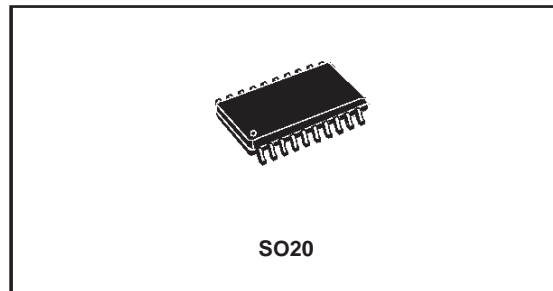

# L6911B

## 5 BIT PROGRAMMABLE POWER SUPPLY CONTROLLER FOR PENTIUM II PROCESSOR

- OPERATING SUPPLY VOLTAGE FROM 5V TO 12V
- TTL-COMPATIBLE 5BIT PROGRAMMABLE OUTPUT FROM:
  - 1.3V TO 2.05V WITH 0.05V BINARY STEPS
  - 2.1V TO 3.5V WITH 0.1V BINARY STEPS
- VOLTAGE MODE PWM CONTROL
- EXCELLENT OUTPUT ACCURACY +/-1% OVERLINE, AND TEMPERATURE VARIATIONS
- HIGH PRECISION INTERNAL REFERENCE DIGITALLY TRIMMED
- VERY FAST LOAD TRANSIENT 0% TO 100% DUTY CYCLE
- POWER GOOD OUTPUT
- OVERVOLTAGE PROTECTION
- OVERCURRENT PROTECTION REALISED USING THE MOSFET'S  $R_{DS(on)}$
- OPERATING FREQUENCY FROM 50KHz TO 1MHz
- MEETS INTEL PENTIUM II SPECIFICATION
- DISABLE FUNCTION



### Applications

- POWER SUPPLY FOR ADVANCED MICRO-PROCESSOR SUPPLIES
- POWER SUPPLY FOR PENTIUM II INTEL PROCESSORS

### DESCRIPTION

The L6911B is a power supply controller specifically designed to provide a high performance DC/DC conversion for Pentium II Microprocessors. A precise 5 bit digital to analog converter

### APPLICATION CIRCUIT

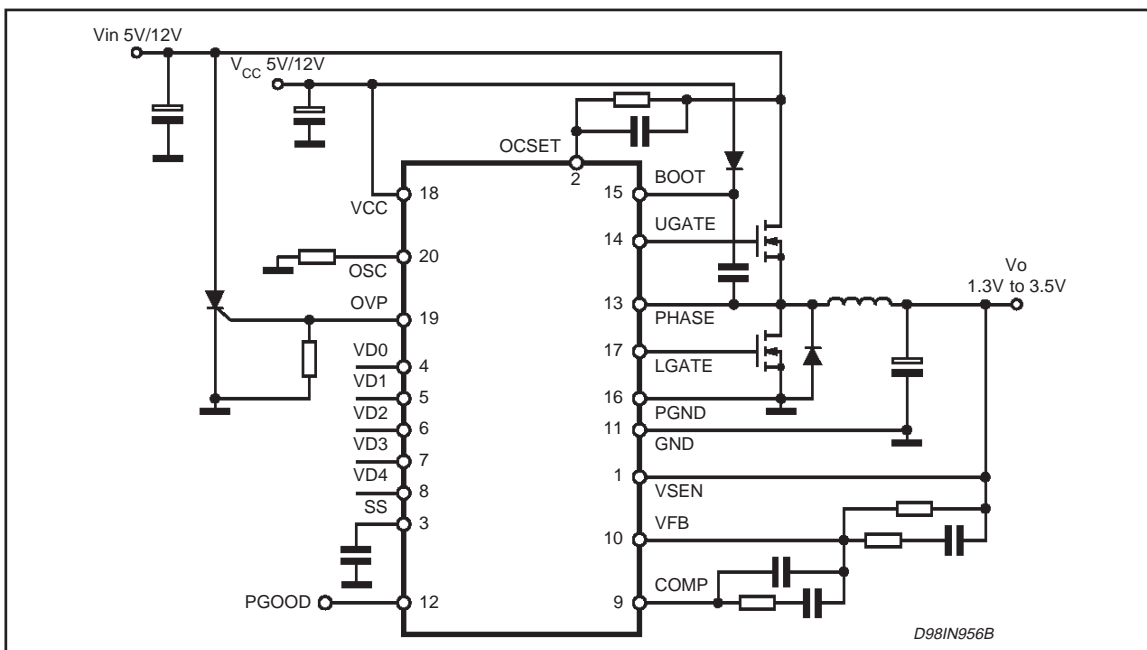

## L6911B

### DESCRIPTION (continued)

(DAC) allows to adjust the output voltage from 1.3V to 2.05V with 0.05V binary steps and from 2.1V to 3.5V with 0.1V binary steps. The high precision internal reference, digitally trimmed, assures the selected output voltage to within +/-1%. Thanks to the window comparator system, the device provides excellent load transient performance. The high peak current gate drive affords to

have fast switching to the external power mos, performing a high efficiency. The L6911B assures a fast protection against load overvoltage and load overcurrent. An external SCR is triggered to crowbar the input supply in case of overvoltage. In case of output short circuit the soft start capacitor is discharged and the system works in hiccup mode.

### ABSOLUTE MAXIMUM RATINGS

Symbol	Parameter	Value	Unit
$V_{CC}$	$V_{CC}$ to PGND	15	V
$V_{BOOT}-V_{PHASE}$	Boot Voltage	15	V
	Input, Output or I/O Voltage	-0.3 to $V_{CC}+0.3$	V

### BLOCK DIAGRAM

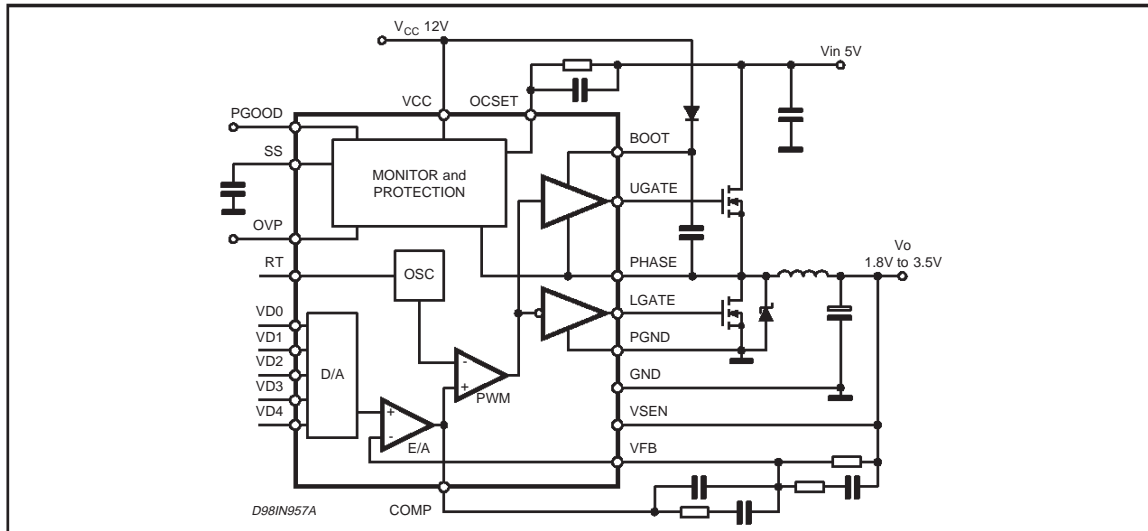

### THERMAL DATA

Symbol	Parameter	Value	Unit
$R_{thj-amb}$	Thermal Resistance Junction to Ambient	110	°C/W
$T_{max}$	Maximum Junction Temperature	150	°C
$T_{stg}$	Storage Temperature Range	-65 to 150	°C

### RECOMMENDED OPERATING CONDITION

Symbol	Parameter	Value	Unit
$V_{CC}$	$V_{CC}$ to PGND	$5V \pm 10\%/12V \pm 10\%$	V
$T_{amb}$	Ambient Temperature Range	0 to 70	°C
$T_J$	Junction Temperature Range	0 to 125	°C

## PIN CONNECTION

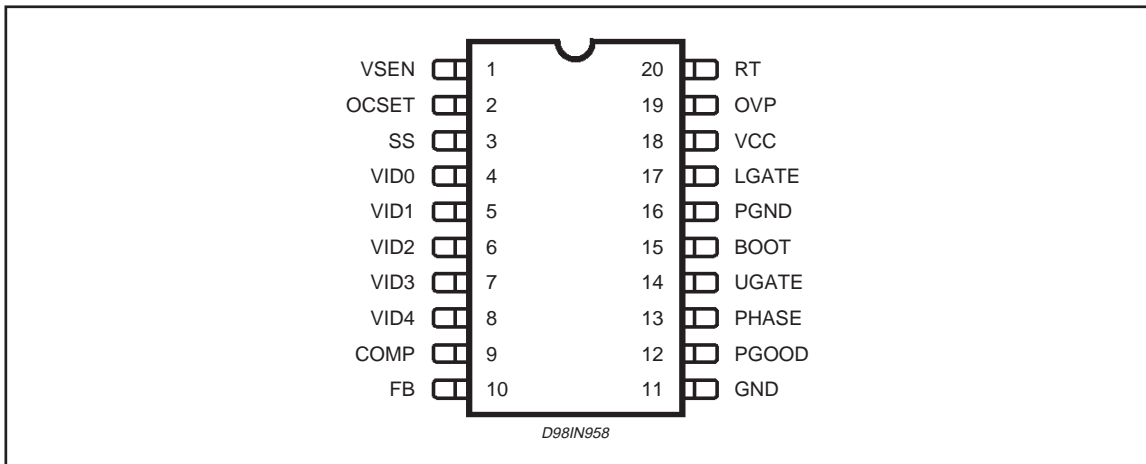

## PIN FUNCTIONS

N°	Name	Description
1	VSEN	Connected to the output voltage is able to manage overvoltage conditions and the PGOOD signal.
2	OCSET	A resistor connected from this pin and the upper Mos Drain sets the current limit protection. The internal 200µA current generator sinks a current from the drain through the external resistor. The overcurrent threshold is due to the following equation: $I_P = \frac{I_{OCS} \cdot R_{OCS}}{R_{dson}}$
3	SS	The soft start time is programmed connecting an external capacitor from this pin and GND. The internal current generator forces through the capacitor 10µA. This pin can be used to disable the device forcing a voltage lower than 0.4V.
4 - 8	VID0 - 4	Voltage Identification code pins. These input are open collector and TTL compatible. Are used to program the output voltage as specified in Table 1 and to set the overvoltage and powergood thresholds.
9	COMP	This pin is connected to the error amplifier output and is used to compensate the voltage control feedback loop.
10	FB	This pin is connected to the error amplifier inverting input and is used to compensate the voltage control feedback loop.
11	GND	All internal voltage reference are referred to this pin.
12	PGOOD	This pin is an open collector output and is pulled low if the output voltage is not within ±10% of the programmed voltage. This pin is forced high if the "11111" VID is set.
13	PHASE	This pin is connected to the source of the upper mosfet and provides the return path for the high side driver. This pin monitors the drop across the upper mosfet for the current limit.
14	UGATE	High side gate driver output.
15	BOOT	Bootstrap capacitor pin. Through this pin is supplied the high side driver and the upper mosfet.
16	PGND	Power ground pin. This pin has to be connected closely to the low side mosfet source in order to reduce the noise injection into the device.
17	LGATE	This pin is the lower mosfet gate driver output.
18	VCC	Device supply voltage. The operative supply voltage range is 4.5V to 12V. Do not connect V <sub>IN</sub> to 12V if V <sub>CC</sub> is 5V.
19	OVP	Over voltage protection. If the output voltage reach the 15% above the programmed voltage this pin is driven high and can be used to drive an external SCR that crowbar the supply voltage.

## PIN FUNCTION (continued)

N°	Name	Description
20	RT	<p>Oscillator Switching frequency pin. Connecting an external resistor from this pin to ground the switching frequency is increased according to the equation:</p> $f_s = 200\text{kHz} + \frac{5 \cdot 10^6}{R_T(\text{K}\Omega)}$ <p>Connecting the resistor from this pin and the V<sub>CC</sub> the Switching frequency is reduced according to the equation:</p> $f_s = 200\text{kHz} - \frac{4 \cdot 10^7}{R_T(\text{K}\Omega)}$ <p>If the pin is not connected the switching frequency is 200kHz.</p>

## ELECTRICAL CHARACTERISTICS

Symbol	Parameter	Test Condition	Min.	Typ.	Max.	Unit
<b>VCC SUPPLY CURRENT</b>						
I <sub>CC</sub>	Supply current	UGATE and LGATE open	-	5	-	mA
<b>POWER-ON</b>						
	Rising V <sub>CC</sub> Threshold	VOCSET = 4.5V	-	-	4.6	V
	Falling V <sub>CC</sub> Threshold	VOCSET = 4.5V	3.6	-	-	V
	Rising VOCSET Threshold		-	1.26	-	V
<b>OSCILLATOR</b>						
	Free Running Frequency	RT = open	185	200	215	kHz
	Total Variation	R <sub>T</sub> to GND >6kΩ, R <sub>T</sub> to V <sub>CC</sub> = 12V > 200kΩ	-15	-	15	%
ΔV <sub>osc</sub>	Ramp Amplitude	RT = open	-	1.9	-	V
<b>REFERENCE and DAC</b>						
	DACOUT voltage Accuracy	VID0, VID1, VID2, VID3 see Table1	-1	-	1	%
<b>ERROR AMPLIFIER</b>						
	DC Gain		-	88	-	dB
GBW	Gain-Bandwidth Product		-	15	-	MHz
SR	Slew Rate	COMP = 10pF	-	10	-	V/μs
<b>GATE DRIVERS</b>						
I <sub>UGATE</sub>	Upper Gate Source	V <sub>BOOT</sub> - V <sub>phase</sub> = 12V, V <sub>UGATE</sub> = 6V	0.6	1	-	A
R <sub>UGATE</sub>	Upper Gate Sink	I <sub>LGATE</sub> = 0.3A	-	1.5	3	Ω
I <sub>LGATE</sub>	Lower Gate Source	V <sub>CC</sub> = 12V, V <sub>LGATE</sub> = 6V	1.2	2	-	A
R <sub>LGATE</sub>	Lower Gate Sink	I <sub>LGATE</sub> = 0.3A	-	1	2	Ω
<b>PROTECTION</b>						
	Overvoltage Trip (V <sub>SEN</sub> /DACOUT)		-	115	120	%
I <sub>OCSET</sub>	OCSET Current Source	V <sub>OCSET</sub> = 4.5VDC	170	200	230	μA
I <sub>OVP</sub>	OVP Sourcing Current	V <sub>SEN</sub> = 5.5V, V <sub>OVP</sub> = 0V	60			mA
I <sub>SS</sub>	Soft Start Current			10		μA

**ELECTRICAL CHARACTERISTICS** (continued)

Symbol	Parameter	Test Condition	Min.	Typ.	Max.	Unit
	Upper Threshold (V <sub>SEN/DACOUT</sub> )	V <sub>SEN</sub> Rising	106	-	111	%
	Upper Threshold (V <sub>SEN/DACOUT</sub> )	V <sub>SEN</sub> Rising	89	-	94	%
	Hysteresis (V <sub>SEN/DACOUT</sub> )	Upper and Lower Threshold	-	2	-	%
V <sub>PGOOD</sub>	PGOOD Voltage Low	I <sub>PGOOD</sub> = -5mA	-	0.5	-	V

**Table 1.**

VID4	VID3	VID2	VID1	VID0	OUTPUT VOLTAGE (V)
0	1	1	1	1	1.3
0	1	1	1	0	1.35
0	1	1	0	1	1.4
0	1	1	0	0	1.45
0	1	0	1	1	1.5
0	1	0	1	0	1.55
0	1	0	0	1	1.6
0	1	0	0	0	1.65
0	0	1	1	1	1.7
0	0	1	1	0	1.75
0	0	1	0	1	1.8
0	0	1	0	0	1.85
0	0	0	1	1	1.9
0	0	0	1	0	1.95
0	0	0	0	1	2
0	0	0	0	0	2.05
1	1	1	1	1	0
1	1	1	1	0	2.1
1	1	1	0	1	2.2
1	1	1	0	0	2.3
1	1	0	1	1	2.4
1	1	0	1	0	2.5
1	1	0	0	1	2.6
1	1	0	0	0	2.7
1	0	1	1	1	2.8
1	0	1	1	0	2.9
1	0	1	0	1	3
1	0	1	0	0	3.1
1	0	0	1	1	3.2
1	0	0	1	0	3.3
1	0	0	0	1	3.4
1	0	0	0	0	3.5

# L6911B

DIM.	mm			inch		
	MIN.	TYP.	MAX.	MIN.	TYP.	MAX.
A	2.35		2.65	0.093		0.104
A1	0.1		0.3	0.004		0.012
B	0.33		0.51	0.013		0.020
C	0.23		0.32	0.009		0.013
D	12.6		13	0.496		0.512
E	7.4		7.6	0.291		0.299
e		1.27			0.050	
H	10		10.65	0.394		0.419
h	0.25		0.75	0.010		0.030
L	0.4		1.27	0.016		0.050
K	0° (min.)8° (max.)					

## OUTLINE AND MECHANICAL DATA

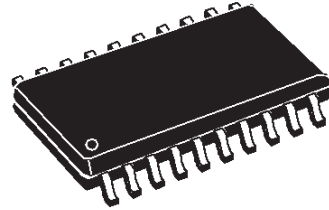

**SO20**

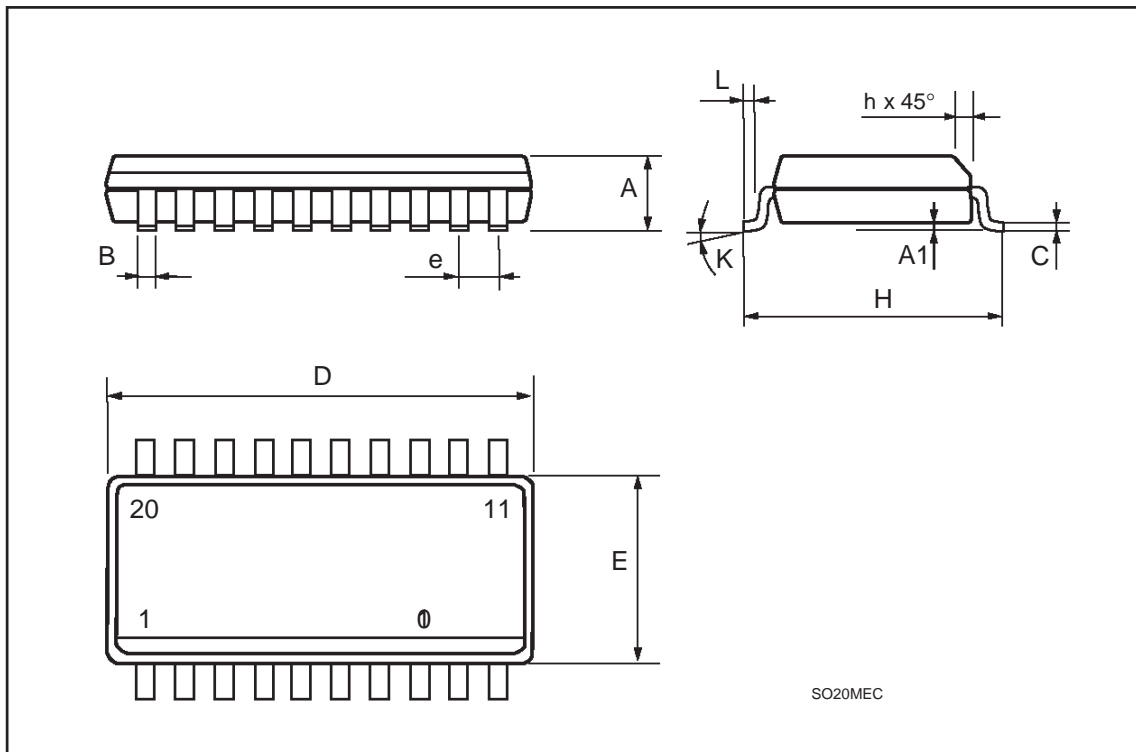

Information furnished is believed to be accurate and reliable. However, STMicroelectronics assumes no responsibility for the consequences of use of such information nor for any infringement of patents or other rights of third parties which may result from its use. No license is granted by implication or otherwise under any patent or patent rights of STMicroelectronics. Specification mentioned in this publication are subject to change without notice. This publication supersedes and replaces all information previously supplied. STMicroelectronics products are not authorized for use as critical components in life support devices or systems without express written approval of STMicroelectronics.

The ST logo is a registered trademark of STMicroelectronics

© 1999 STMicroelectronics – Printed in Italy – All Rights Reserved

STMicroelectronics GROUP OF COMPANIES

Australia - Brazil - Canada - China - France - Germany - Italy - Japan - Korea - Malaysia - Malta - Mexico - Morocco - The Netherlands - Singapore - Spain - Sweden - Switzerland - Taiwan - Thailand - United Kingdom - U.S.A.

<http://www.st.com>

