

LM64032 Additional Info

The Datasheet only gives pinout information for a 10 Pin connector which is in the centre of the LCD Pcb.

My LCD actually has a 2nd connector which is a 14 Pin this is how the two connectors relate.

14 Pin Conn	10 Pin Conn
1	N/C
2	1
3	2
4,7,14	4
5	3
6,8	5
9	6
10	7
11	8
12	9
13	10

Simon Hampton (23-06-99)

www.DataSheet.in

PREPARED BY:	DATE	<h1>SHARP</h1> <p>ELECTRONIC COMPONENTS GROUP SHARP CORPORATION</p> <h2>SPECIFICATION</h2>	SPEC No. LC 62921A
APPROVED BY:	DATE		FILE No.
			ISSUE Sep. 5, 1987
			PAGE Pages
			REPRESENTATIVE DIVISION
			<input type="checkbox"/> SEMICONDUCTOR APPLICATION DIV. <input checked="" type="checkbox"/> LCD DIV. <input type="checkbox"/> ELECTRONIC COMPONENTS DIV. <input type="checkbox"/>

DEVICE SPECIFICATION FOR
640 X 200 Dot
 Graphic LCD Unit

MODEL No.
LM64032B

www.DataSheet.in

CUSTOMER'S APPROVAL

DATE _____

BY _____

PRESENTED
 BY H. Nakajima

H. Nakajima
 Department General Manager
 Engineering Department 1
 LCD Division
 ELECOM Group
 SHARP CORPORATION

MODEL No. LM 64032 B

PAGE 1

SHARP**1. Application**

This data sheet is to introduce the specification of the Dot-Matrix LCD Unit LM 64032B

2. Construction and Outline

Construction : 640X200 full dot graphic display unit consisting of an LCD panel ,PWB(printed wiring board) with electric components mounted onto,TAB(tape automated bonding) to connect the LCD panel and PWB electrically, and plastic chassis and bezel to fix them mechanically.

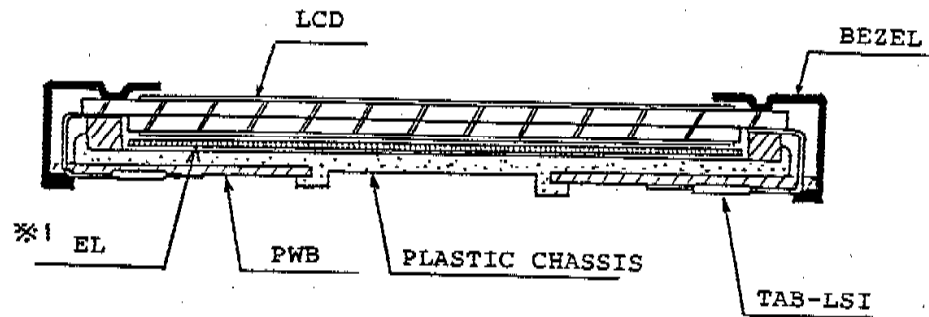

Outline: See Fig. 8

Connection: See Fig. 8 and Table 6

There shall be no scratches, chips, stains, distortions and other external drawbacks that may affect the display function.

Rejection criteria shall be noted in Inspection Standard S-U-006

(*1) Three types of EL backlight are available as optional;

LFOB	(White)
LFOB	(Blue-green)
LFOB	(Green)

For each model, refer to the separate specification please.

v.

MODEL No.

LM64032B

PAGE

2

SHARP

3. Mechanical Specifications

Table 1

Parameter	Specifications	Unit
Outline dimensions * 1	256(W) x 128(H) x 12(D Max)	mm
Effective viewing area	223.9(W) x 97.9(H)	mm
Display format	640 (W) x 200(H) full dots	-
Dot size	0.32(W) x 0.46(H)	mm
Dot spacing	0.03	mm
Dot color * 2	WHITE	-
Background color * 2	DARK BLUE	-
Weight	Approx. 320	g

* 1 Excluded the mounting tab. (See Fig.8)

* 2 Due to the characteristics of the LC Material, the colors vary with environmental temperature.

4. Absolute Maximum Ratings

4-1. Electrical Absolute Maximum Ratings

Table 2

Parameter	Symbol	Min.	Max.	Unit	Remark
Supply voltage (Logic)	$V_{DD}-V_{SS}$	0	6.0	V	Ta = 25°C
Supply voltage (LCD drive)	$V_{DD}-V_{EE}$	0	31.5	V	Ta = 25°C
Input voltage	V_{IN}	0	V_{DD}	V	Ta = 25°C

MODEL No

LM64032B

PAGE

3

SHARP4-2. Environmental Conditions Table 3

Item	Tstg		Topr		Remark
	MIN.	MAX.	MIN.	MAX.	
Ambient temperature	-25°C	+60°C	0°	+45°C	Note 4
Humidity	Note 1		Note 1		No condensation
Vibration	Note 2		Note 2		3 directions (X/Y/Z)
Shock	Note 3		Note 3		6 directions (±X/±Y/±Z)

Note 1) $T_a \leq 40^\circ\text{C}$ 95% RH Max
 $T_a > 40^\circ\text{C}$ Absolute humidity shall be less than $T_a = 40^\circ\text{C}/$
 95% RH.

Note 2) Frequency: 10 ~ 55Hz
 Vibration width: 1.5mm
 Interval: 10Hz ~ 55Hz ~ 10Hz
 (1 min)
 2 hours for each direction of X/Y/Z (6 hours as total)

Note 3) Acceleration: 50G
 Pulse width: 1ms
 3 times for each direction of ±X/±Y/±Z.

Note 4) Care should be taken so that the LCD Unit
 may not be exposed the temperature ranges out of
 this specifications.

SHARP

MODEL No

LM64032 B

PAGE

4

5. Electrical Specifications

5-1. Electrical characteristics

Table 4

$T_a = 25^\circ\text{C}$, $V_{DD} - 5V \pm 5\%$

Parameter	Symbol	Conditions	Min.	Typ.	Max.	Unit
Supply voltage (Logic)	$V_{DD}-V_{SS}$		4.75	5.0	5.25	V
Supply voltage (LCD drive)	$V_{EE}-V_{SS}$	Note	-26.2	-21.1	-14.6	V
Input signal voltage	V_{IN}	"H" level	$0.8V_{DD}$		V_{DD}	V
		"L" level	0		$0.2V_{DD}$	V
Input leakage current	I_{IL}	"H" level			20	μA
		"L" level	-20			μA
Supply current (Logic)	I_{DD}	$V_{EE} = -21.1V$ $V_{DD} = 5V$, Frame frequency = 60Hz display high frequency pattern		26.5	33	mA
Supply current (LCD drive)	I_{EE}			19	23.5	mA
Power consumption	P_d			534	661	mW

Note) The viewing angle θ where obtains the maximum contrast can be set by adjusting above $V_{EE} - V_{SS}$. Refer to Fig. for the definition of θ .
 Max. and Min. values are specified as the Max. and Min. voltage within the condition of operational temperature range ($0^\circ\text{C} \sim 45^\circ\text{C}$).
 Typ. values are specified as the typical voltage at 25°C .

5-2. Input capacitance

Table 5

Signal	Input capacitance
S	40 pF TYP
CP ₁	110 pF TYP
CP ₂	90 pF TYP
D ₀ ~D ₃	90 pF TYP
	pF TYP
	pF TYP

MODEL No
LM64032BPAGE
5**SHARP****5-3. Interface signals****Table 6**

Pin No.	Symbol	Description	Level
1	S	Scan start-up signal	"H"
2	CP ₁	Input data latch signal	H → L
3	CP ₂	Data input clock signal	H → L
4	VDD	Power supply for logic and LCD (+)	-
5	VSS	Ground potential	-
6	VEE	Power supply for LCD (-)	-
7	D ₀	Display data signal	H(ON), L(OFF)
8	D ₁		
9	D ₂		
10	D ₃		

Used connector: FFC (P 1.25)

MODEL No.
LM64032B

PAGE
6

SHARP

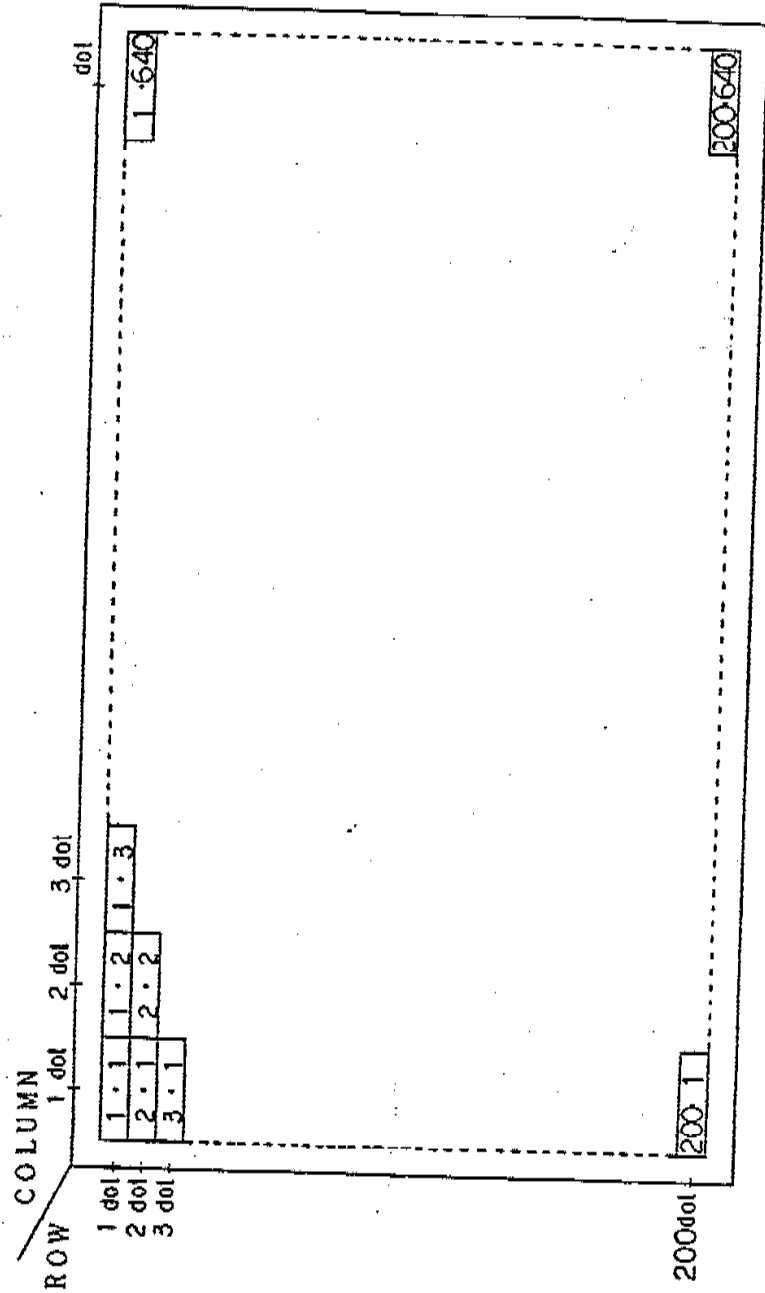

Note: 1 dot 2 dot means 1st row 2nd column dot.

Fig.1 Dot Chart of Display Area

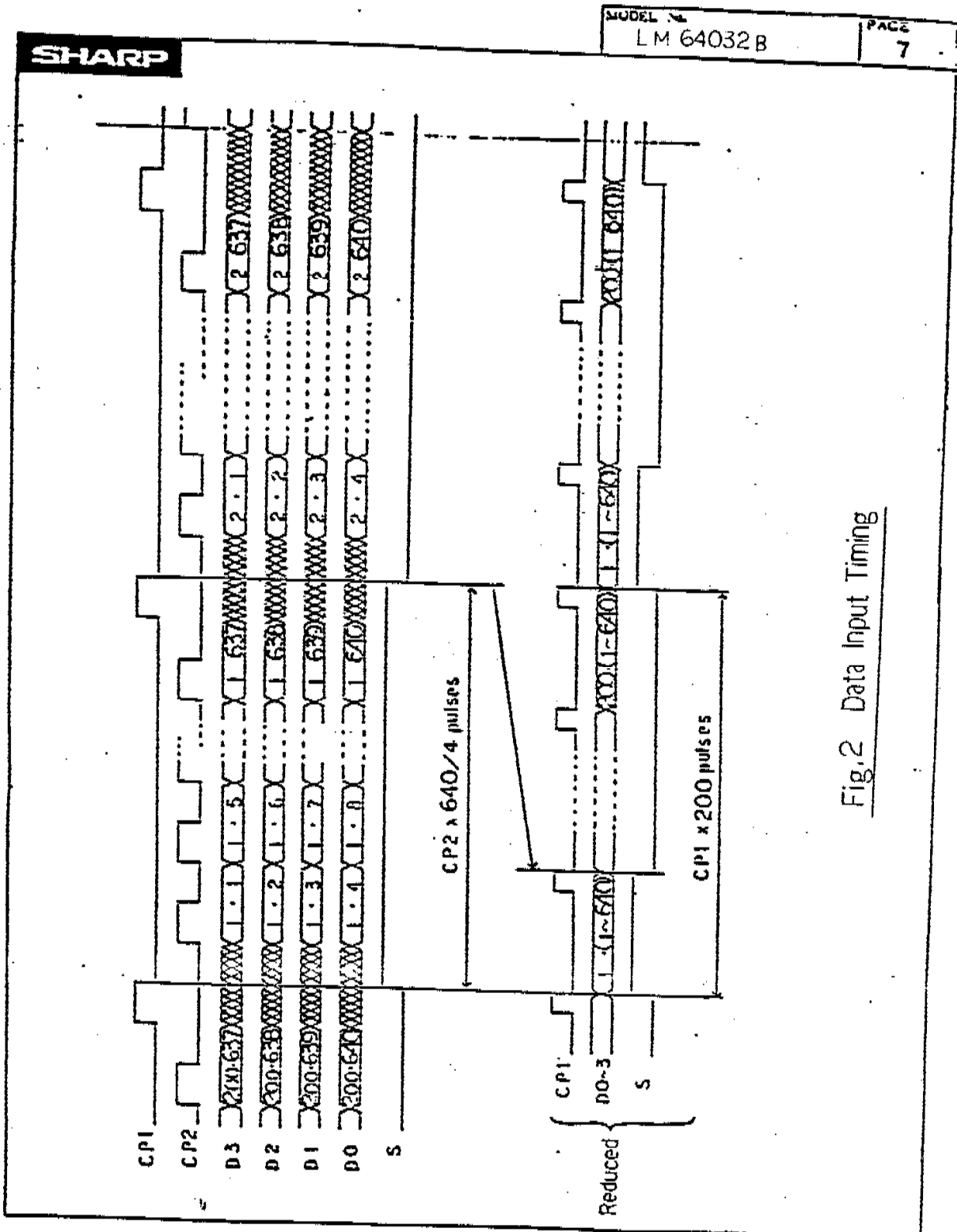

Fig.2 Data Input Timing

SHARP

MODEL No
LM64032 B

PAGE
9

Table 7 Interface timing ratings

Item	Symbol	Rating			Unit
		MIN.	TYP.	MAX.	
Frame cycle	TFRM	13.69		20.40	ms
CP2 clock cycle	TCP2	400			ns
"H" level clock width	tCHH	145			ns
"L" level clock width	tCWL	145			ns
"H" level latch clock width	tLHH	130			ns
Date set up time	tSU	70			ns
Date hold time	tH	50			ns
CP2↑ clock allowance time from CP1↓	tS12	0			ns
CP1↑ clock allowance time from CP2↓	tS21	0			ns
Clock rise/fall time	t _{r,tf}			50	ns

SHARP

6. Unit Driving Method

6.1 Circuit Configuration

Fig. 7 shows the block diagram of the Unit's circuitry.

6.2 Display Face Configuration

The display face electrically consists of two (upper and lower) display segments so that the unit may offer higher contrast by reducing drive duty ratio. Each display segment (640x200dots) is driven at 1/200duty ratio.

6.3 Input Data and Control Signal

The LCD driver is 80 bits LSI, consisting of shift registers, latch circuits and LCD driver circuits.

Display data which are externally divided into data for each row (640dots) will be sequentially transferred in the form of 4-bit parallel data through shift registers by Clock Signal CP₂ from the left top of the display face.

When data of one row (640dots) have been inputted, then latched in the form of parallel data for 640 lines of signal electrodes by Latch Signal CP₁. Then the corresponding drive signal will be transmitted to the 640 lines of column electrodes of the LCD panel by the LCD drive circuits.

At this time, scan start-up signal S has been transferred from the scan signal driver to the 1st row of scan electrodes, and the contents of the data signals are displayed on the 1st rows of upper and lower half of the display face according to the combinations of voltages applied to the scan and signal electrodes of the LCD. While the 1st rows of data are being displayed, the 2nd rows of data are entered. When 640dots of data have been transferred then latched on the falling edge of CP₁ clock, the display face proceeds to the 2nd rows of display.

Such data input will be repeated up to the 200th row of each display segment, from upper to lower rows, to complete one frame of display by time sharing method. Then data input proceeds to the next display face.

Scan start-up Signal S generates scan signal to drive horizontal electrodes.

The unit shall be driven at the speed of 50-60Hz/frame to avoid flickering.

Since DC voltage, if applied to LCD panel, causes chemical reaction which will deteriorate LCD panel, drive waveform shall be inverted at every display frame to prevent the generation of such DC voltage. Control Signal M plays such role.

SHARP

Because of the characteristics of the CMOS driver LSI, the power consumption of the unit goes up as the operating frequency CP₂ increases. Thus the driver LSI applies the system of transferring 4-bit parallel data through the 4 lines of shift registers to reduce the data transfer speed CP₂. Thanks to the LSI, the power consumption of the unit will be minimized.

In this circuit configuration, 4-bit display data shall be therefore inputted to data input pins of D 0-3.

Furthermore the LCD unit adopts bus line system for data input to minimize the power consumption. In this system data input terminal of each driver LSI is activated only when relevant data input is fed.

Data input for column electrodes of both the upper and the lower display segment and chip select of driver LSI are made as follows:

The driver LSI at the left end of the display face is first selected, and the adjacent driver LSI of the right side is selected when 80 dots data(20CP₂) is fed. This process is sequentially continued until data is fed to the driver LSI at the right end of the display face.

This process is simultaneously followed at the column driver LSI's of both the upper and the lower display segments. Thus data input for both the upper and the lower display segments must be fed through 4-bit bus line sequentially from the left end of the display face.

Since this graphic display unit contains no refresh RAM, it requires data and timing pulse inputs even for static display.

The timing chart of input signals are shown in Fig. 3.

SHARP

7. Optical Characteristics

Table 8

($T_a = 25^\circ\text{C}$)

$V_{DD} = 5\text{V}$

$V_{EE} = -21.1 V_{TP}$

Following spec. are based upon the electrical measuring condition, on which the contrast of perpendicular direction ($\theta = 0^\circ$) will be MAX. ($V_{EM} = -18.7V_{MIN} \sim -24.0V_{MAX}$)

Parameter	Symbol	Condition	Min.	Typ.	Max.	Unit	Remark	
Viewing angle range	$\theta_2 - \theta_1$	$\phi = 0^\circ$ $\theta_1 < \theta_2$	$C_0 \geq 2.0$	55	-	-	dgr.	Note 1
	θ_1		-	-	-25	dgr.	Note 1	
	θ_2	$C_0 = 2.0$	25	-	-	dgr.	Note 1	
	$\theta_2 - \theta_1$	$\phi = 45^\circ$ $\phi = 315^\circ$ $\theta_1 < \theta_2$	$C_0 \geq 2.0$	55	-	-	dgr.	Note 1
	θ_1		-	-	-25	dgr.	Note 1	
	θ_2		$C_0 = 2.0$	25	-	-	dgr.	Note 1
Contrast ratio	C_0	$\theta = 0^\circ, \phi = 0^\circ$	3.5	5.0	-		Note 2	
Response speed	Rise	T_r	-	100	200	ms	Note 3	
	Decay	T_d	-	200	300	ms	Note 3	

Note 1) The viewing angle range may be defined as shown below.

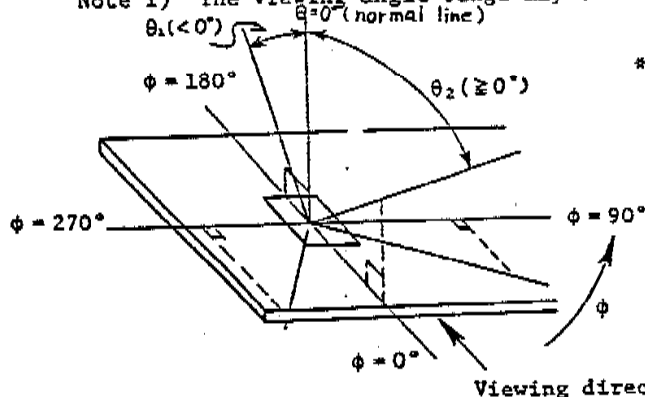

* Angles θ_1 , θ_2 and ϕ shall fall within the range over which the displayed character can be read.

Fig. 4 Definition of Viewing Angle

Note 2) Contrast ratio may be defined as follows:

Contrast ratio is calculated by using the following formula when the waveform voltage (Fig. 6) is applied in the optical characteristics test method (Fig. 5).

$$\text{Contrast ratio} = \frac{\text{Photo-detector output voltage with select waveform being applied}}{\text{Photo-detector output voltage with non-select waveform being applied}}$$

Measuring wavelength $\lambda = 540 \text{ nm}$.

SHARP

Note 3) The response characteristics of photo-detector output are measured as shown in Fig. 6, assuming that input signals are applied so as to select and deselect the dots to be measured, in the optical characteristics test method shown in Fig. 5.

616
KETHLEY
DIGITAL
ELECTRO
METER

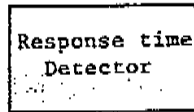
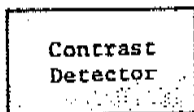

TEKTRONIX
TYPE549
STORAGE
OSCILLOSCOPE

Note 4) Table 8 shows the optical characteristics detected when the LCD applied voltage waveforms are in the highest frequency*.

* The most critical condition for the characteristics of LCD.

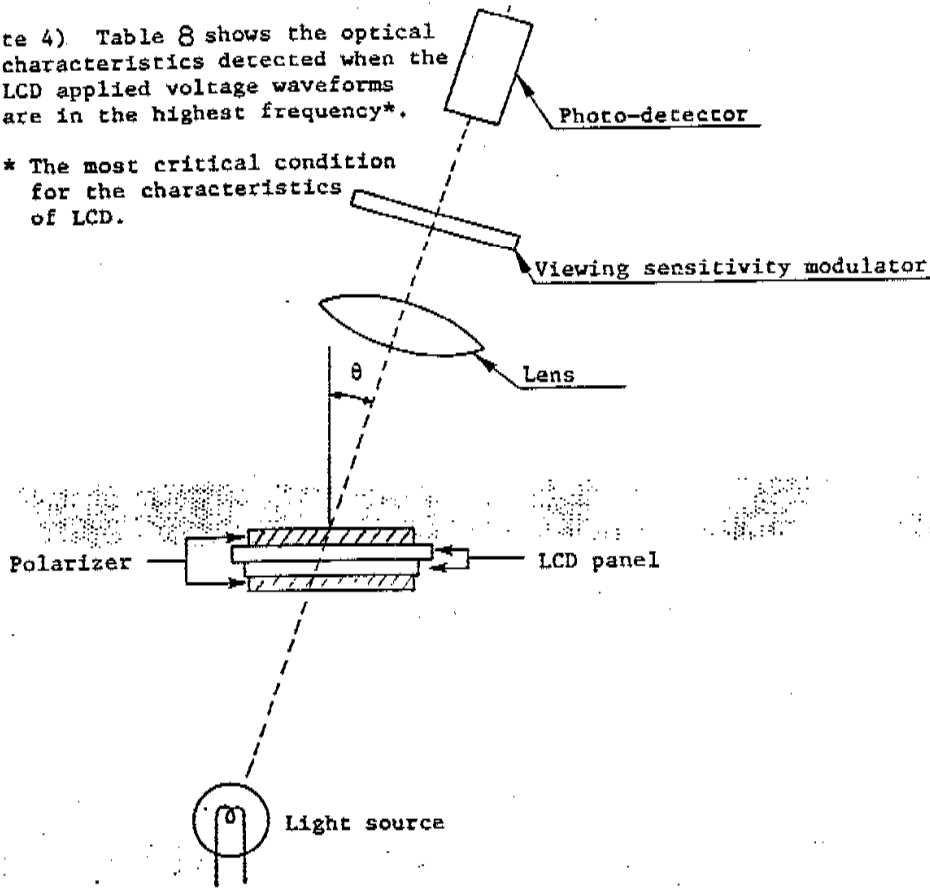

Fig. 5 Optical Characteristics Test Method

MODEL No
LM64032 BPAGE
14

SHARP

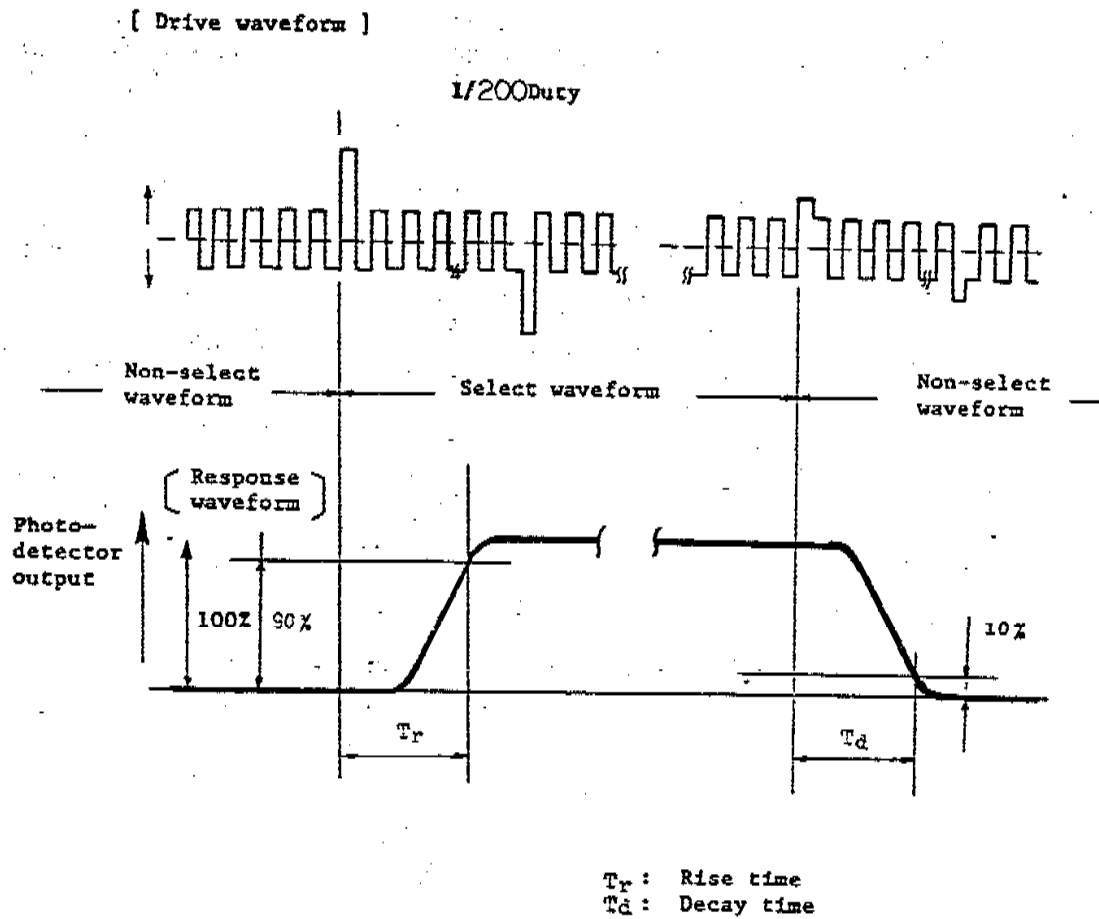
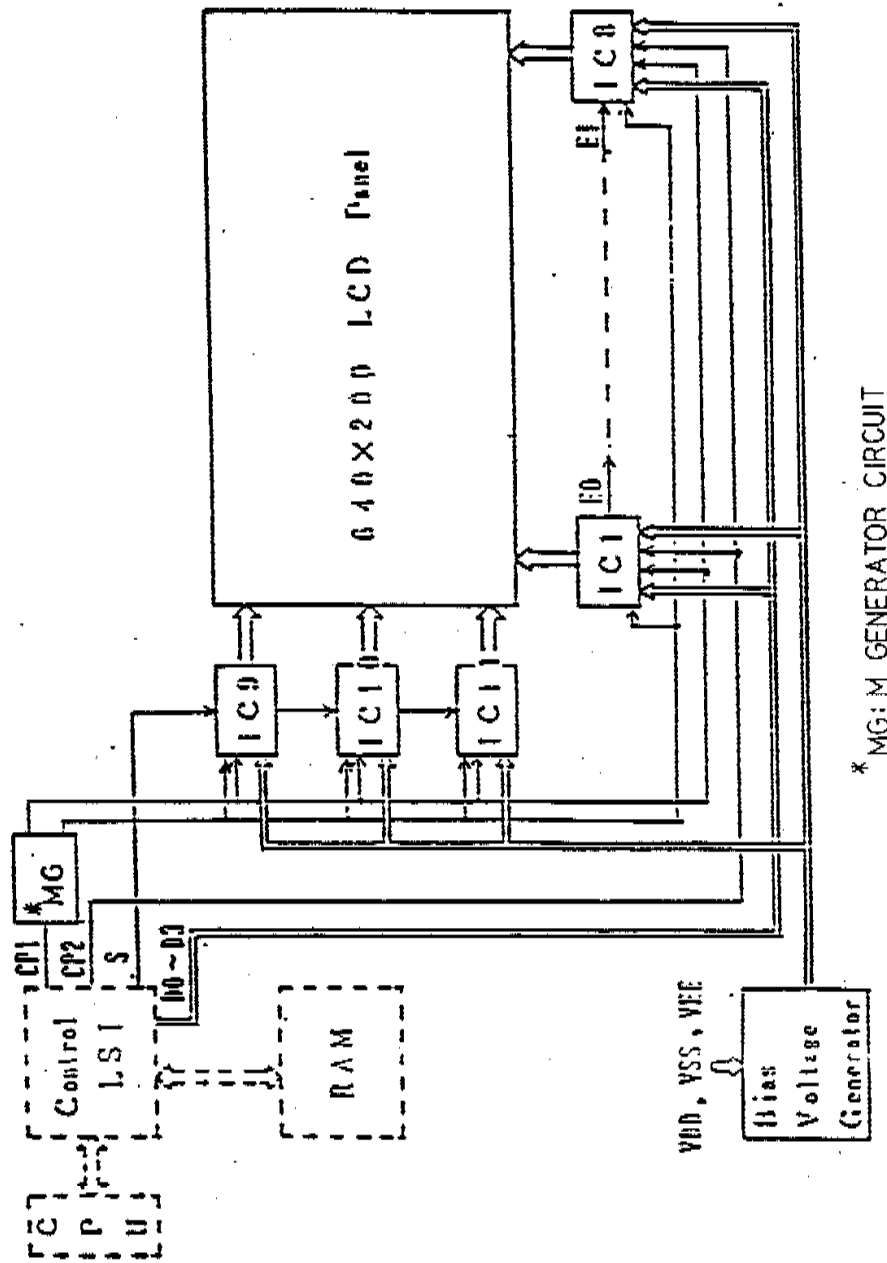

Fig. 6 Definition of Response Time

SHARP

Fig.7 Circuit block diagram



* MG: M GENERATOR CIRCUIT

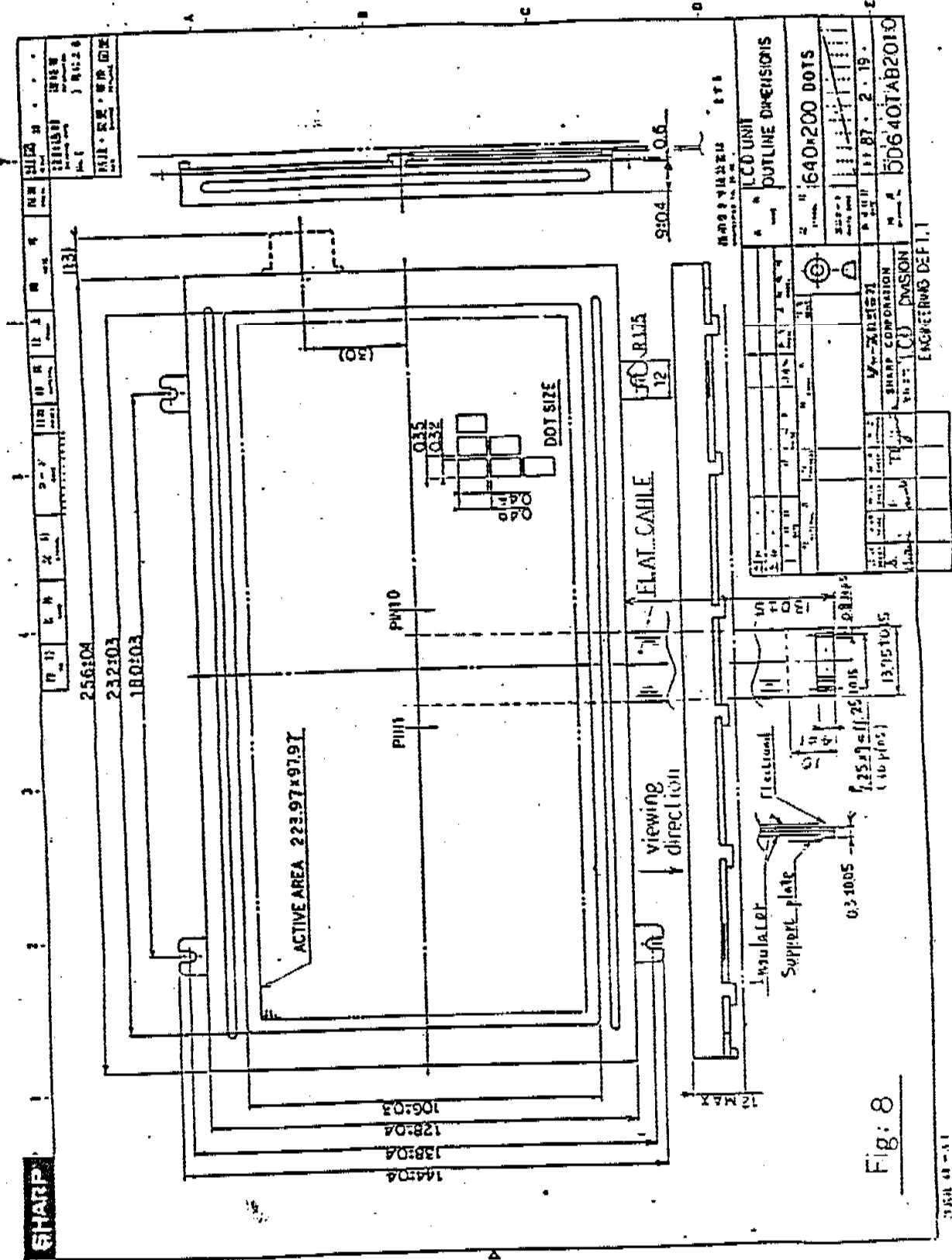

Fig: 8

SHARP 48-3-1

SHARP**8. Precautions****8.1 Angle when installing the unit**

This unit's viewing angle is illustrated in Fig.9 .

$$\theta_1 < \text{viewing range} < \theta_2 \quad (\theta_1 < 0^\circ, \theta_2 \geq 0^\circ)$$

(For the specific values of θ_1 , θ_2 , refer to the Table 8.)

Please consider the optimum viewing conditions according to the purpose when installing the unit.

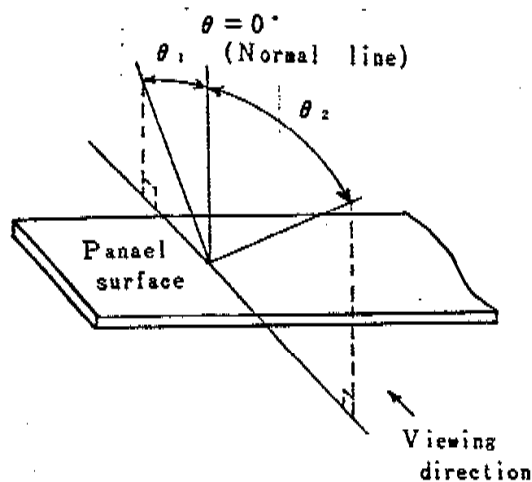

Fig.9 Dot matrix LCD viewing angle

8.2 Handling cautions

This unit is installed using mounting tabs at the four corners of PCB or bezel.

When installing the unit, pay attention and handle carefully not to allow any undue stress such as twist or bend.

A transparent acrylic resin board or other type of protective panel should be attached to the front of the unit to protect the polarizer, LCD cells, etc.

MODEL No

LM64032 B

PAGE

18

SHARP

8.3 Notes on attachment

- (1) Since the front polarizer is easily damaged, please pay attention not to scratch on its face.
- (2) If the surface of the LCD cells needs to be cleaned, wipe it swiftly with cotton or other soft cloth. If still not completely clear, blow on it and wipe.
- (3) Water droplets, etc. must be wiped off immediately since they may cause color changes, staining, etc. if remained for a long time.
- (4) Since LCD is made of glass plates, dropping the unit or banging it against hard objects may cause cracking or fragmentation.
- (5) CMOS LSIs are equipped in this unit, so care must be taken to avoid the electro static charge, by earthing human body, etc. Take the following measures, to protect the unit from the electric discharge via mounting tabs from the main system electrified with static electricity.
 - (1) Earth the metallic case of the main system (contact of the unit and main system).
 - (2) Insulate the unit and main system by attaching insulating washers made of bakelite or nylon, etc.

8.4 Notes on operation

- (1) The unit should be driven according to the specified ratings to avoid malfunction of permanent damage. DC voltage drive leads to rapid deterioration of LC, so ensure that the drive is alternating waveform by continuous application of the signal M.

8.5 Others

- (1) Avoid to expose the unit to the direct sun-light, strong ultra-violet light, etc. for a long time.
- (2) If stored at temperatures below specified storage temperature, the LC may freeze and be deteriorated. If storage temperature exceed the specified rating, the molecular orientation of the LC may change to that of a liquid, and they may not revert to their original state. As far as possible always store at normal room temperature.
- (3) If the LCD panel is removed from the LCD unit, it may cause the poor contact on reinsertion. So please avoid to dismantle the unit.