

HALL EFFECT PICKUP IGNITION CONTROLLER

- DIRECT DRIVING OF THE EXTERNAL POWER DARLINGTON
- COIL CURRENT CHARGING ANGLE (dwell) CONTROL
- PROGRAMME COIL CURRENT PEAK LIMITATION
- PROGRAMMABLE DWELL RECOVERY TIME WHEN 94 % NOMINAL CURRENT NOT REACHED
- RPM OUTPUT
- PERMANENT CONDUCTION PROTECTION
- OVERVOLTAGE PROTECTION FOR EXTERNAL DARLINGTON
- INTERNAL SUPPLY ZENER
- REVERSE BATTERY PROTECTION

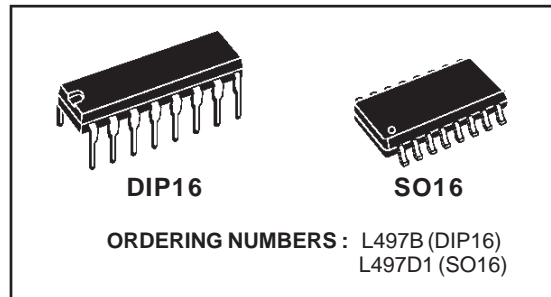

The device drives an NPN external darlington to control the coil current providing the required stored energy with low dissipation.

A special feature of the L497 is the programmable time for the recovery of the correct dwell ratio T_d/T when the coil peak current fails to reach 94 % of the nominal value. In this way only one spark may have an energy less than 94 % of the nominal one during fast acceleration or cold starts.

DESCRIPTION

The L497 is an integrated electronic ignition controller for breakerless ignition systems using Hall effect sensors.

BLOCK DIAGRAM

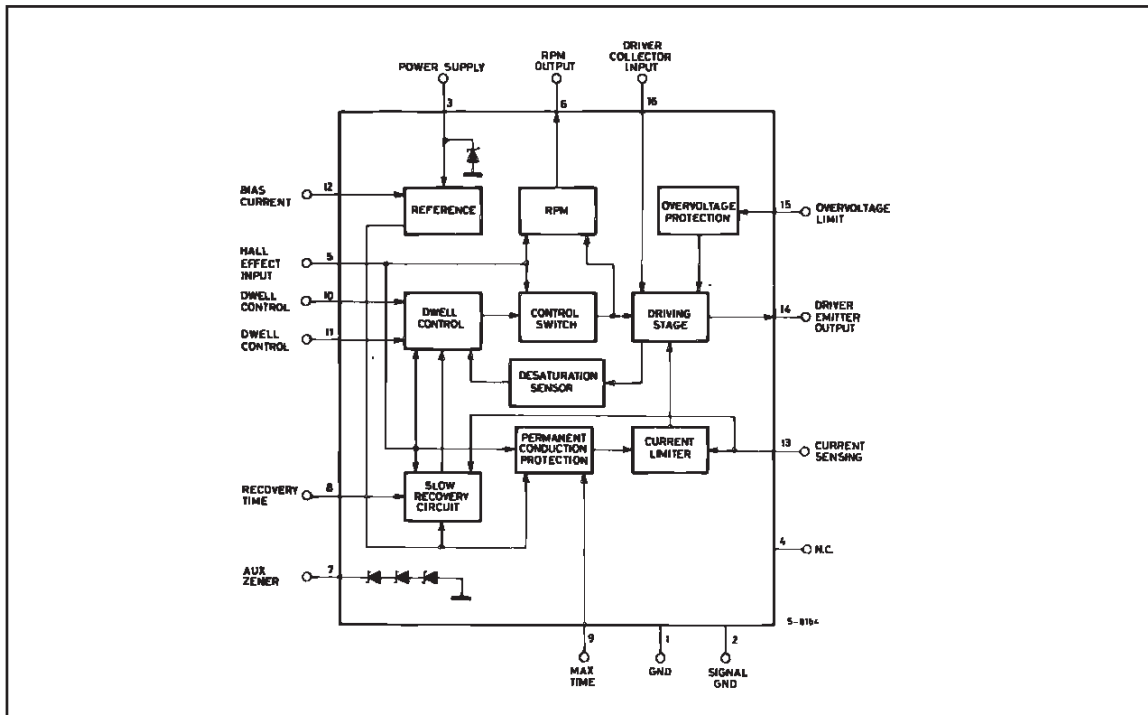

ABSOLUTE MAXIMUM RATINGS

| Symbol | Parameter | Value | Unit |
|-----------------------------------|-----------------------------------------------------------------------------------|---------------------------------|----------|
| I ₃ | D.C. Supply current | 200 | mA |
| | Transient Supply Current (t _f fall time constant = 100ms) | 800 | mA |
| V ₃ | Supply Voltage | Int. Limited to V _{Z3} | |
| V ₆ | RPM Voltage | 28 | V |
| I ₁₆ | D.C. Driver Collector Current | 300 | mA |
| | Pulse " " (t ≤ 3ms) | 600 | mA |
| V ₁₆ | Driver Collector Voltage | 28 | V |
| I ₇ | Auxiliary Zener Current | 40 | mA |
| I ₁₅ | D.C. Overvoltage Zener Current | | |
| | Pulse " " t _{fall} = 300μs, t _{rep} Repetition Time > = 3ms | 15 35 | mA mA |
| V _R | Reverse Battery Voltage if Application Circuit of Fig. 4 is used | - 16 | V |
| T _j , T _{stg} | Junction and Storage Temperature Range | - 55 to 150 | °C |
| P _{tot} | Power Dissipation | | |
| | at T _{aluminia} = 90 °C for SO-16 T _{amb} = 90 °C for DIP-16 | 1.2 0.65 | W W |

PIN CONNECTION (top view)

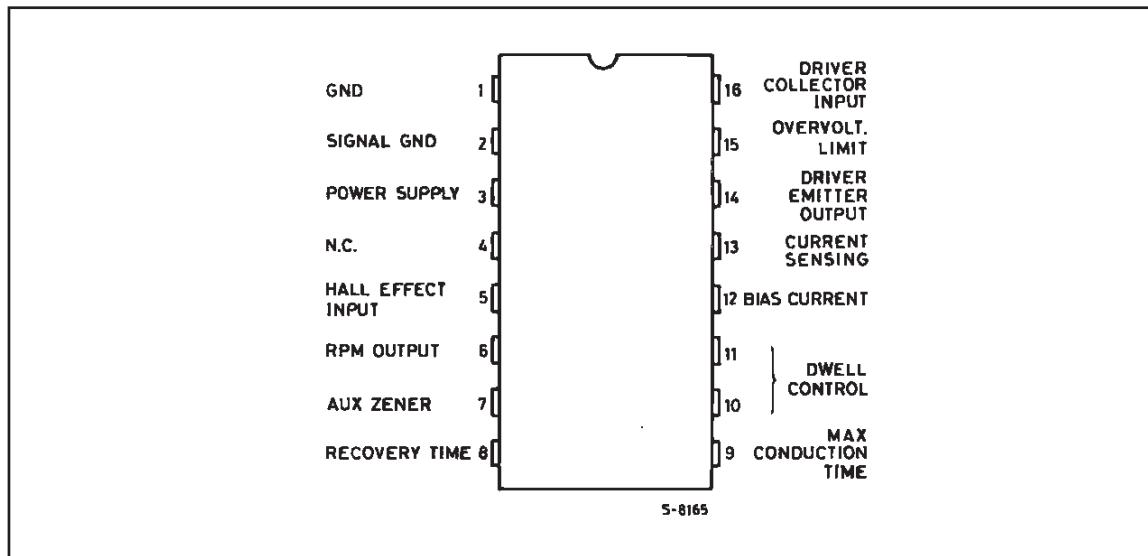

THERMAL DATA

| Symbol | Parameter | Value | Unit |
|------------------------------|------------------------------------------------|--------|------|
| R _{th j-amb} | Thermal Resistance Junction-ambient for DIP-16 | Max 90 | °C/W |
| R _{th j-alumin (*)} | Thermal Resistance Junction-alumina for SO-16 | Max 50 | °C/W |

(*) Thermal resistance junction-alumina with the device soldered on the middle of an alumina supporting substrate measuring 15 x 20 ; 0.65 mm thickness.

PIN FUNCTIONS (refer to fig. 4)

| N° | Name | Function |
|----|---------------------|--------------------------------------------------------------------------------------------------------------------------------------------------------------------------------------------------------------------------------------------------------------------------------------------------------------------------------------------------------------------------------------------------------------------------------------------------------------------------------------------------------------------------------------------|
| 1 | GND | This pin must be connected to ground. |
| 2 | SIGNAL GND | This pin must be connected to ground. |
| 3 | POWER SUPPLY | Supply Voltage Input. An internal 7.5 V (typ) zener limits the voltage at this pin. The external resistor R ₅ limits the current through the zener for high supply voltages. |
| 4 | N.C. | This pin must be connected to ground or left open. |
| 5 | HALL-EFFECT INPUT | Hall-effect Pickup Signal Input. This input is dwell control circuit output in order to enable the current driving into the coil. The spark occurs at the high-to-low transition of the hall-effect pickup signal. Furthermore this input signal enables the slow recovery and permanent conduction protection circuits. The input signal, supplied by the open collector output stage of the Hall effect sensor, has a duty-cycle typically about 70 %. V ₅ is internally clamped to V ₃ and ground by diodes |
| 6 | RPM OUTPUT | Open collector output which is at a low level when current flows in the ignition coil. For high voltages protection of this output, connection to the pin 7 zener is recommended. In this situation R ₈ must limit the zener current, too, and R ₁ limits pin 6 current if RPM module pad is accidentally connected to V _S . |
| 7 | AUX. ZENER | A 21 V (typ) General Purpose Zener. Its current must be limited by an external resistor. |
| 8 | RECOVERY TIME | A capacitor connected between this pin and ground sets the slope of the dwell time variation as it rises from zero to the correct value. This occurs after the detection of I _{coll} ≤ 94 % I _{nom} , just before the low transition of the hall-effect signal pulse. The duration of the slow recovery is given by : t _{src} = 12,9 R ₇ C _{src} (ms) where R ₇ is the biasing resistor at pin 12 (in KΩ) and C _{src} is the delay capacitor at pin 8 (in μF). |
| 9 | MAX CONDUCTION TIME | A capacitor connected between this pin and ground determines the intervention delay of the permanent conduction protection. After this delay time the coil current is slowly reduced to zero. Delay Time T _p is given by : T _p = 16 C _p R ₇ (ms) where R ₇ is the biasing resistor at pin 12 (in KΩ) and C _p is the delay capacitor at pin 9 (in μF). |
| 10 | DWELL CONTROL TIMER | A capacitor C _T connected between this pin and ground is charged when the HALL effect output is High and is discharged at the High to Low transition of the Hall effect signal. The recommended value is 100 nF using a 62 KΩ resistor at pin 12. |
| 11 | DWELL CONTROL | The average voltage on the capacitor C _W connected between this pin and ground depends on the motor speed and the voltage supply. The comparison between V _{CW} and V _{CT} voltage determines the timing for the dwell control. For the optimized operation of the device C _T = C _W ; the recommended value is 100 nF using a 62 KΩ resistor at pin 12. |
| 12 | BIAS CURRENT | A resistor connected between this pin and ground sets the internal current used to drive the external capacitors of the dwell control (pin 10 and 11) permanent conduction protection (pin 9) and slow recovery time (pin 8). The recommended value is 62 KΩ. |
| 13 | CURRENT SENSING | Connection for the Coil Current Limitation. The current is measured on the sensing resistor R _S and taken through the divider R ₁₀ /R ₁₁ . The current limitation value is given by : $I_{sens} = 0.32 \cdot \frac{R_{10} + R_{11}}{R_S \cdot R_{11}}$ |

PIN FUNCTIONS (continued)

| N° | Name | Function |
|----|------------------------|----------------------------------------------------------------------------------------------------------------------------------------------------------------------------------------------------------------------------------------------------------------------------------------------------------------------------------------------------------------------------------------------------------------------------------------------------|
| 14 | DRIVER EMITTER OUTPUT | Current Driver for the External Darlington. To ensure stability and precision of T_{desat} C_c and R_9 must be used. Recommended value for R_9 is 2 K Ω in order not to change the open loop gain of the system. R_c may be added to C_c to obtain greater flexibility in various application situations. C_c and R_c values ranges are 1 to 100 nF and 5 to 30 K Ω depending on the external darlington type. |
| 15 | OVERVOLTAGE LIMIT | The darlington is protected against overvoltage by means of an internal zener available at this pin and connected to pin 14. The internal divider R_3/R_2 defines the limitation value given by : $V_{ovp} = \left(\frac{22.5}{R_3} + 5.10^{-3} \right) R_2 + 22.5$ |
| 16 | DRIVER COLLECTOR INPUT | The collector current of the internal driver which drives the external darlington is supplied through this pin. Then the external resistor R_6 limits the maximum current supplied to the base of the external darlington. |

ELECTRICAL CHARACTERISTICS ($V_S = 14.4$ V, -40 °C < T_j < 125 °C unless otherwise specified)

| Symbol | Parameter | Test Conditions | Min. | Typ. | Max. | Unit |
|-----------------------------|-------------------------------------------------------------------------------------------|-----------------------------------------------------------------------|----------|--------------|------------|----------|
| V_3 | Min Op. Voltage | | 3.5 | | | V |
| I_3 | Supply Current | $V_3 = 6$ V $V_3 = 4$ V | 5 7 | 18 | 25 13 | mA mA |
| V_S | Voltage Supply | | | | 28 | V |
| V_{Z3} | Supply Clamping Zener Voltage | $I_{Z3} = 70$ mA | 6.8 | 7.5 | 8.2 | V |
| V_5 | Input Voltage | Low Status High Status | | | 0.6 | V V |
| I_5 | Input Current | $V_5 = \text{LOW}$ | - 400 | | - 50 | μ A |
| V_{16-14} | Darlington Driver Sat. Current | $I_{14} = 50$ mA $I_{14} = 180$ mA | | | 0.5 0.9 | V V |
| V_{SENS} | Current Limit. Sensing Voltage | $V_S = 6$ to 16 V | 260 | 320 | 370 | mV |
| I_{11C} | CW Charge Current | $V_S = 5.3$ to 16V $V_{11} = 0.5$ V $T = 10$ to 33ms | - 11.0 | - 9.3 | - 7.8 | μ A |
| I_{11D} | CW Charge Current | $V_S = 5.3$ to 16V $V_{11} = 0.5$ V $T = 10$ to 33ms | 0.5 | 0.7 | 1.0 | μ A |
| I_{11C} / I_{11D} | | $V_S = 5.3$ to 16V $V_{11} = 0.5$ V $T = 10$ to 33ms See Note 1 | 7.8 | | 22.0 | |
| $\frac{I_{SRC}}{I_{SENSE}}$ | Percentage of Output Current Determining the Slow Recovery Control Start (fig. 2), note 1 | | 90 | 94 | 98.5 | % |
| T_{SRC} | Duration of Altered Small Contr. Ratio after SRC Function Start (fig. 2) | $C_{SRC} = 1$ μ F $R_7 = 62$ K Ω | | 0.8 | | s |
| V_{Z15} | External Darlington over V Prot. Zener Voltage | $I_{15} = 5$ mA $I_{15} = 2$ mA | 19 18 | 22.5 21.5 | 26 25 | V V |
| T_P | Permanent Conduction Time | $V_5 = \text{High}$ $C_P = 1$ μ F $R_7 = 62$ K Ω | 0.4 | 1.1 | 1.8 | s |

ELECTRICAL CHARACTERISTICS (continued)

| Symbol | Parameter | Test Conditions | Min. | Typ. | Max. | Unit |
|----------------------|-------------------------------|-------------------------|------|------|------|---------------|
| V_{6SAT} | RPM Output Saturation Voltage | $I_6 = 18.5 \text{ mA}$ | | | 0.5 | V |
| | | $I_6 = 25 \text{ mA}$ | | | 0.8 | V |
| $I_{6 \text{ leak}}$ | RPM Output Leakage Current | $V_S = 20 \text{ V}$ | | | 50 | μA |
| V_{Z7} | Auxiliary Zener Voltage | $I_7 = 20 \text{ mA}$ | 19 | | 27 | V |
| V_{12} | Reference Voltage | | 1.20 | 1.25 | 1.30 | V |

- Notes : 1. t_d/t desaturation ratio is given by: $\frac{t_d}{T} = \frac{1}{1 + I_{11C} / I_{11D}}$
2. $I_{\text{sense}} = I_{\text{coil}}$ When the external Darlington is in the active region.

APPLICATION INFORMATION

Figure 1 : Main Waveforms.

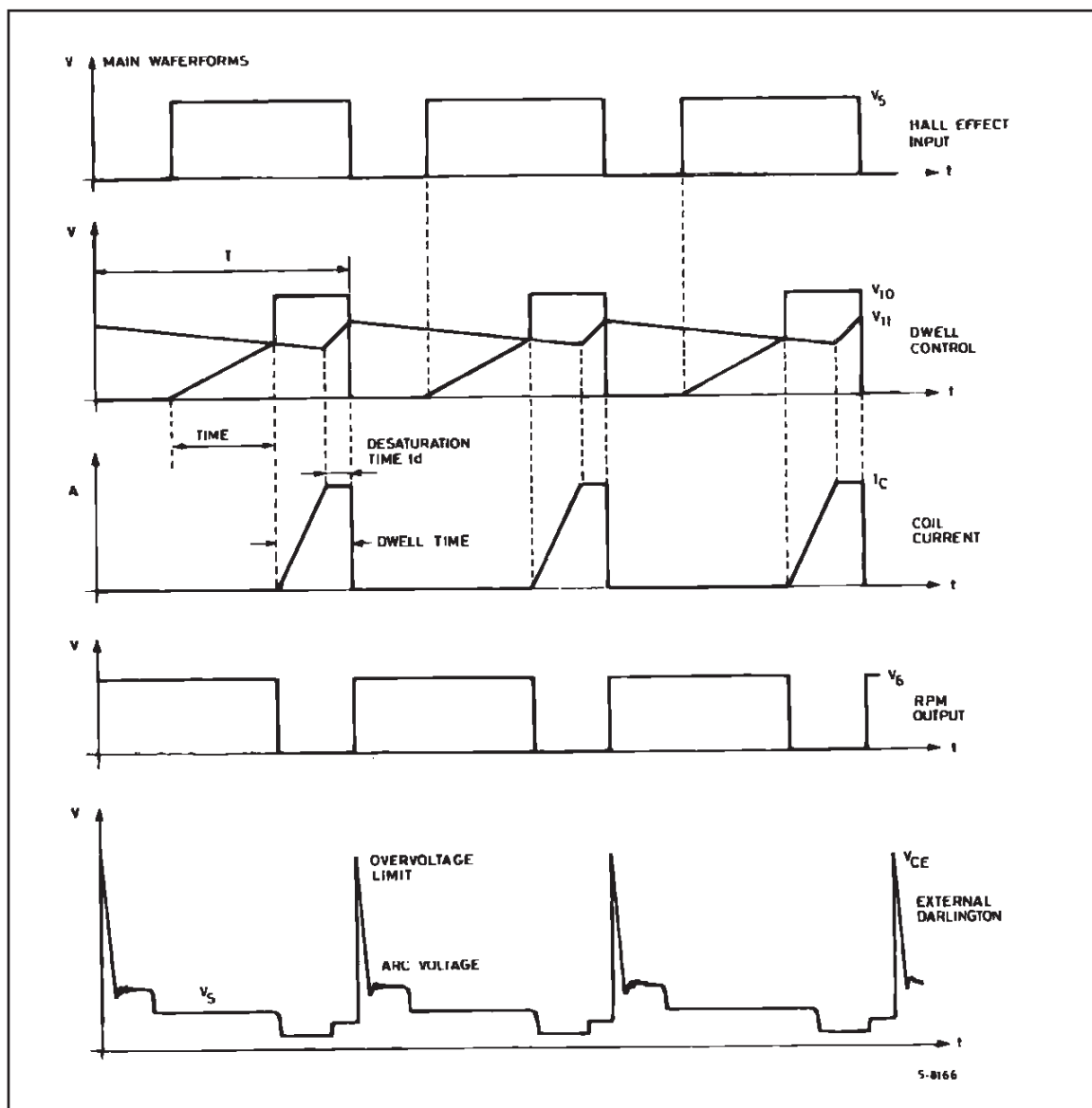

DWELL ANGLE CONTROL

The dwell angle control circuit calculates the conduction time D for the output transistor in relation to the speed of rotation, to the supply voltage and to the characteristics of the coil.

On the negative edge of the Hall-effect input signal the capacitor C_W begins discharging with a constant current I_{11D} . When the set peak value of the coil current is reached, this capacitor charges with a constant current $I_{11C} = 13.3 \times I_{11D}$, and the coil current is kept constant by desaturation of the driven stage and the external darlington.

The capacitor C_T starts charging on the positive edge of the Hall-effect input signal with a constant current I_{10C} . The dwell angle, and consequently the starting point of the coil current conduction, is decided by the comparison between V_{10} and V_{11} .

A positive hysteresis is added to the dwell comparator to avoid spurious effects and C_T is rapidly discharged on the negative edge of Hall-effects input signal.

In this way the average voltage on C_W increases if the motor speed decreases and viceversa in order to maintain constant the ratio $\frac{t_d}{T}$ at any motor speed.

$\frac{t_d}{T}$ is kept constant (and not $\frac{D}{T} = \text{cost}$) to control the power dissipation and to have sufficient time to avoid low energy sparks during acceleration.

DESATURATION TIMES IN STATIC CONDITIONS

In static conditions and if $C_T = C_W$ as recommended and if the values of the application circuit of fig.4 are used.

$$\frac{t_d}{T} = \frac{1}{1 + I_{11C} / I_{11D}}$$

DESATURATION TIMES IN LOW AND HIGH FREQUENCY OPERATION

Due to the upper limit of the voltage range of pin 11, if the components of fig.4 are used, below 10 Hz (300 RPM for a 4 cylinder engine) the OFF time reaches its maximum value (about 50 ms) and then the circuit gradually loses control of the dwell angle because $D = T - 50 \text{ ms}$.

Over 200 Hz (6000 RPM for a 4 cylinder engine) the available time for the conduction is less than 3.5 ms.

If the used coil is 6 mH, 6A, the OFF time is reduced to zero and the circuit loses the dwell angle control.

TRANSIENT RESPONSE

The ignition system must deliver constant energy even during the condition of acceleration and deceleration of the motor below 80Hz/s. These conditions can be simulated by means of a signal generator with a linearly modulated frequency between 1 Hz and 200 Hz (this corresponds to a change between 30 and 6000 RPM for a 4 cylinders engine).

CURRENT LIMIT

The current in the coil is monitored by measuring the I_{sense} current flowing in the sensing resistor R_s on the emitter of the external darlington. I_{sense} is given by :

$$I_{\text{sense}} = I_{\text{coil}} + I_{14}$$

When the voltage drop across R_s reaches the internal comparator threshold value the feedback loop is activated and I_{sense} kept constant (fig.1) forcing the external darlington in the active region. In this condition :

$$I_{\text{sense}} = I_{\text{coil}}$$

When a precise peak coil current is required R_s must be trimmed or an auxiliary resistor divider (R_{10} , R_{11}) added :

$$I_{\text{cpeak}}(\text{A}) = \frac{0.320}{R_s} \cdot \left(\frac{R_{10}}{R_{11}} + 1 \right)$$

SLOW RECOVERY CONTROL (fig. 2)

If I_{sense} has not reached 94 % of the nominal value just before the negative edge of the Hall-effect input signal, the capacitor C_{src} and C_W are quickly discharged as long as the pick-up signal is "low". At the next positive transition of the input signal the load current starts immediately, producing the maximum achievable T_{desat} ; then the voltage on C_{src} increases linearly until the standby is reached. During this recovery time the C_{src} voltage is converted into a current which, substrated from the charging current of the dwell capacitor, produces a T_{desat} modulation. This means that the T_{desat} decreases slowly until its value reaches, after a time T_{src} , the nominal 7% value.

The time T_{src} is given by:

$$T_{\text{src}} = 12.9 R_7 C_{\text{src}} (\text{ms})$$

where R_7 is the biasing resistor at pin 12 (in $K\Omega$) and C_{src} the capacitor at pin 8 (in μF).

Figure 2 : SRC : I_{coil} Failure and Time Dependence of Active Region.

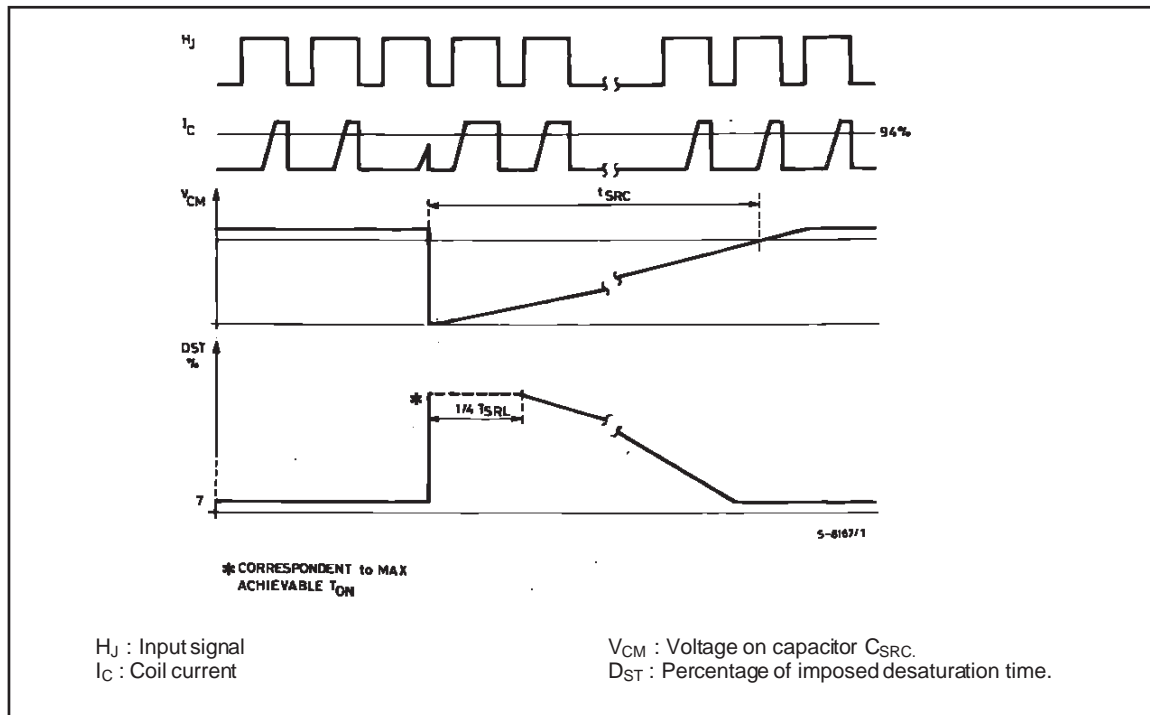
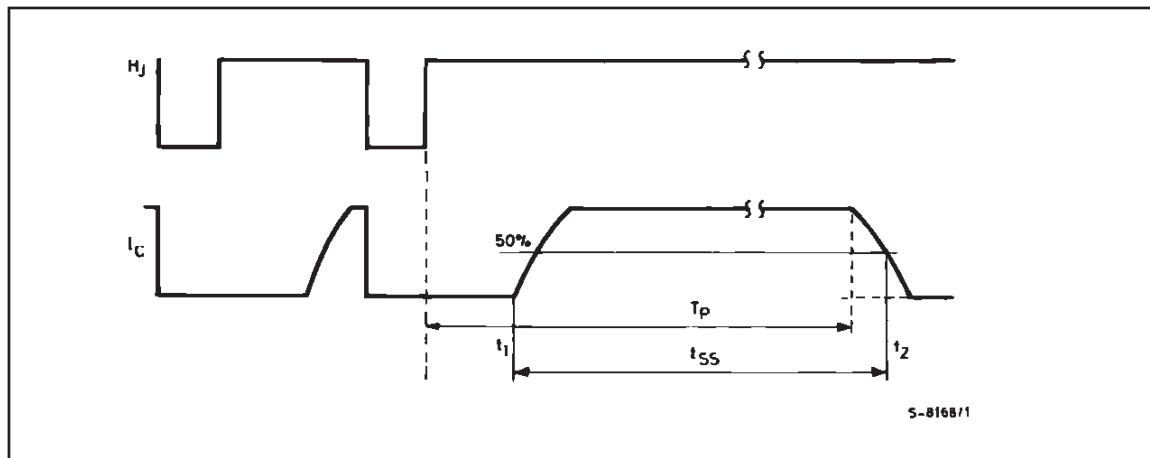

Figure 3 : Permanent Conduction Protection.



PERMANENT CONDUCTION PROTECTION (fig. 3)

The permanent conduction protection circuit monitors the input period, charging C_P with a constant current when the sensor signal is high and discharging it when the sensor signal is low. If the input remains high for a time longer than T_P the voltage across C_P reaches an internally fixed value forcing the slow decrease of coil current to zero. A slow decrease is

necessary to avoid undesired sparks. When the input signal goes low again C_P is swiftly discharged and the current control loop operates normally.

The delay time T_P is given by :

$$T_P (\text{sec}) = 18 C_P R_7$$

Where R_7 is the biasing resistor on pin 12 (in K) and C_P the delay capacitor at pin 9 (in μF).

OTHER APPLICATION NOTES

DUMP PROTECTION

Load dump protection must be implemented by an external zener if this function is necessary. In fig. 4 DZ₂ protects the driver stage, the connection between pin 6 and 7 protects the output transistor of pin 6. Moreover DZ₁ protects both the power supply input (pin 3) and Hall-effect sensor.

Resistor R₄ is necessary to limit DZ₁ current during load dump.

OVERVOLTAGE LIMITATION

The external darlington collector voltage is sensed by the voltage divider R₂, R₃. The voltage limitation increases rising R₂ or decreasing R₃.

Due to the active circuit used, an R_o C_o series net-

work is mandatory for stability during the high voltage condition.

R_o C_o values depend on the darlington used in the application.

Moreover the resistor R₁₃ is suggested to limit the overvoltage even when supply voltage is disconnected during the high voltage condition.

REVERSE BATTERY PROTECTION

Due to the presence of external impedance at pin 6, 3, 16, 15 L497 is protected against reverse battery voltage.

NEGATIVE SPIKE PROTECTION

If correct operation is requested also during short negativespikes, the diode D_s and capacitor C_s must be used.

Figure 4 : Application Circuit.

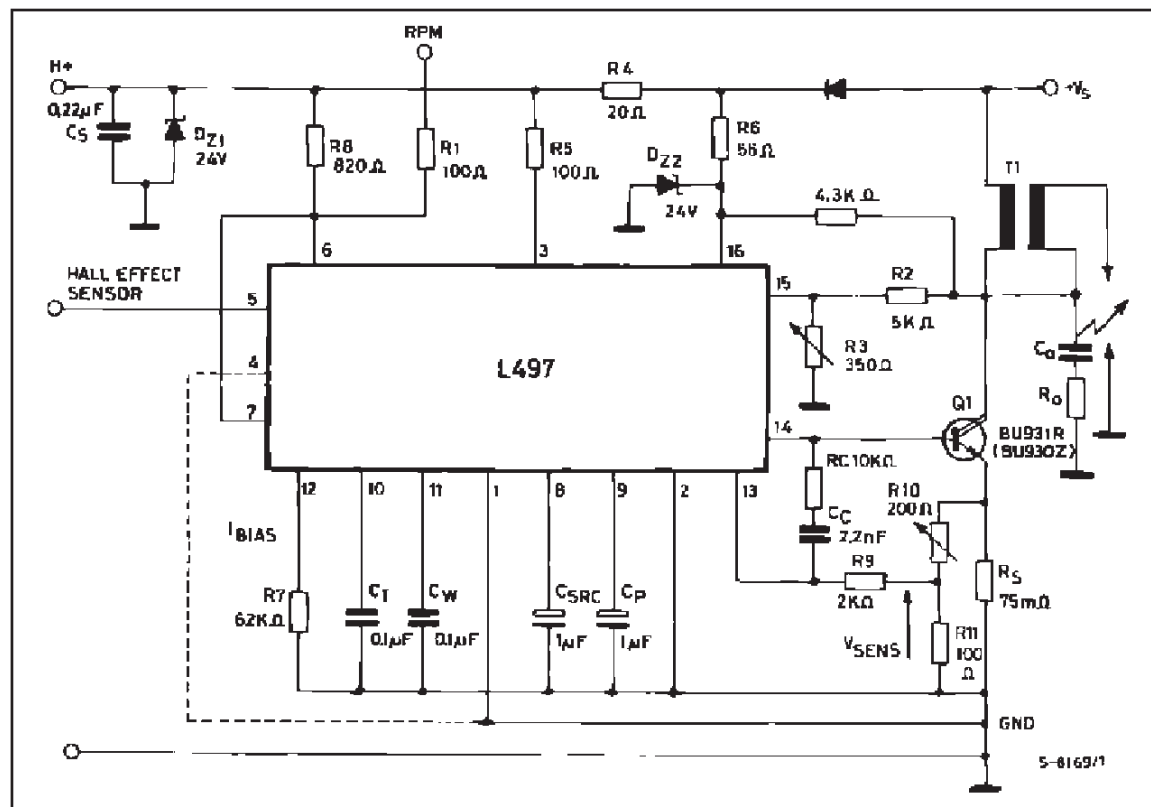

DIP16 PACKAGE MECHANICAL DATA

| DIM. | mm | | | inch | | |
|------|------|-------|------|-------|-------|-------|
| | MIN. | TYP. | MAX. | MIN. | TYP. | MAX. |
| a1 | 0.51 | | | 0.020 | | |
| B | 0.77 | | 1.65 | 0.030 | | 0.065 |
| b | | 0.5 | | | 0.020 | |
| b1 | | 0.25 | | | 0.010 | |
| D | | | 20 | | | 0.787 |
| E | | 8.5 | | | 0.335 | |
| e | | 2.54 | | | 0.100 | |
| e3 | | 17.78 | | | 0.700 | |
| F | | | 7.1 | | | 0.280 |
| I | | | 5.1 | | | 0.201 |
| L | | 3.3 | | | 0.130 | |
| Z | | | 1.27 | | | 0.050 |

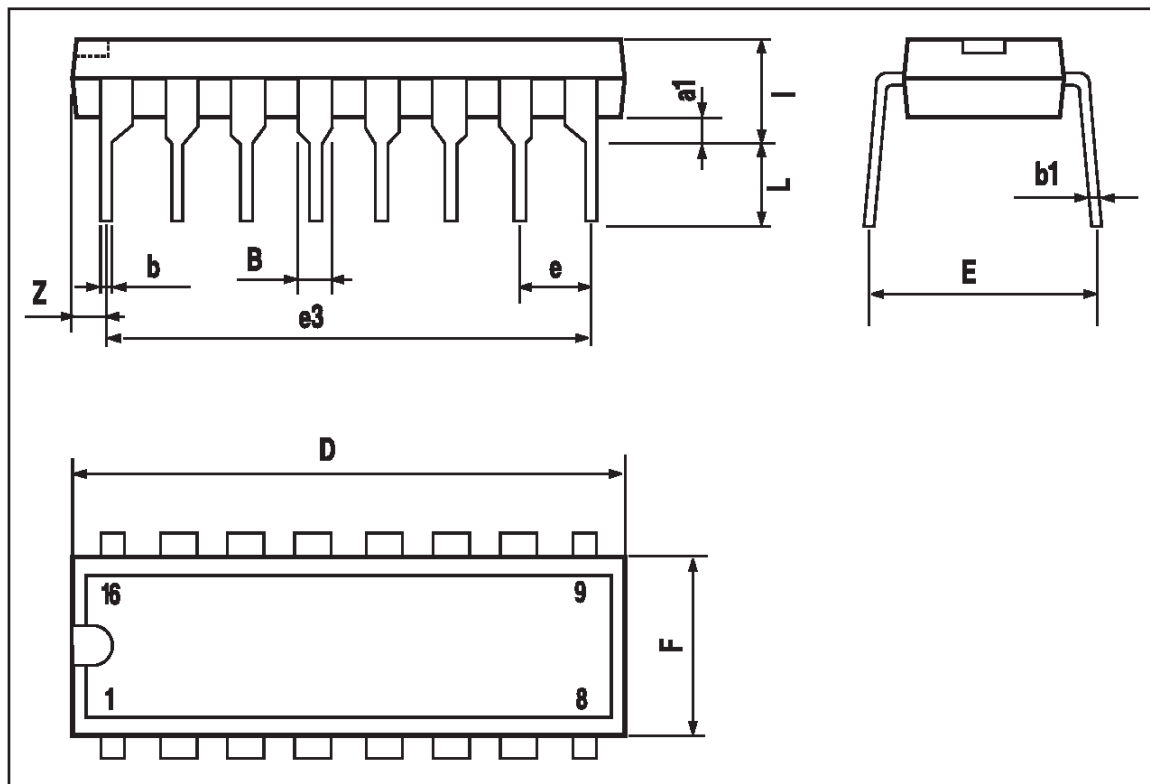

SO16 PACKAGE MECHANICAL DATA

| DIM. | mm | | | inch | | |
|------|------------|------|------|-------|-------|-------|
| | MIN. | TYP. | MAX. | MIN. | TYP. | MAX. |
| A | | | 1.75 | | | 0.069 |
| a1 | 0.1 | | 0.2 | 0.004 | | 0.008 |
| a2 | | | 1.6 | | | 0.063 |
| b | 0.35 | | 0.46 | 0.014 | | 0.018 |
| b1 | 0.19 | | 0.25 | 0.007 | | 0.010 |
| C | | 0.5 | | | 0.020 | |
| c1 | 45° (typ.) | | | | | |
| D | 9.8 | | 10 | 0.386 | | 0.394 |
| E | 5.8 | | 6.2 | 0.228 | | 0.244 |
| e | | 1.27 | | | 0.050 | |
| e3 | | 8.89 | | | 0.350 | |
| F | 3.8 | | 4.0 | 0.150 | | 0.157 |
| L | 0.5 | | 1.27 | 0.020 | | 0.050 |
| M | | | 0.62 | | | 0.024 |
| S | 8° (max.) | | | | | |

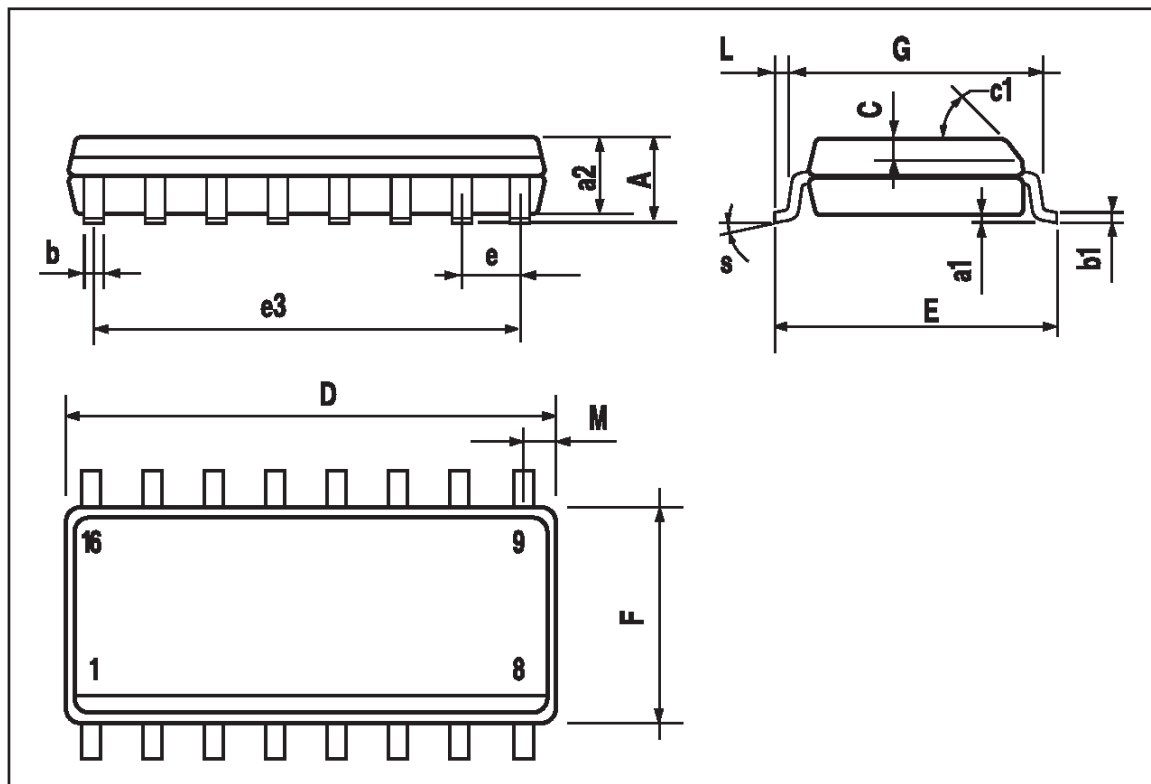

Information furnished is believed to be accurate and reliable. However, SGS-THOMSON Microelectronics assumes no responsibility for the consequences of use of such information nor for any infringement of patents or other rights of third parties which may result from its use. No license is granted by implication or otherwise under any patent or patent rights of SGS-THOMSON Microelectronics. Specification mentioned in this publication are subject to change without notice. This publication supersedes and replaces all information previously supplied. SGS-THOMSON Microelectronics products are not authorized for use as critical components in life support devices or systems without express written approval of SGS-THOMSON Microelectronics.

© 1998 SGS-THOMSON Microelectronics – Printed in Italy – All Rights Reserved

SGS-THOMSON Microelectronics GROUP OF COMPANIES

Australia - Brazil - Canada - China - France - Germany - Italy - Japan - Korea - Malaysia - Malta - Morocco - The Netherlands - Singapore - Spain - Sweden - Switzerland - Taiwan - Thailand - United Kingdom - U.S.A.