

## D.C. TREBLE AND BASS STEREO CONTROL CIRCUIT

The TCA740A is a monolithic integrated circuit for controlling treble and bass in stereo amplifiers by means of a d.c. voltage.

### Features:

- two double potentiometer circuits
- feedback control
- internal amplifier
- high-ohmic signal inputs
- converter for the control voltages
- low-ohmic and short-circuit protected signal outputs

### QUICK REFERENCE DATA

Supply voltage (pin 8)	$V_p$	typ.	15 V
Supply current (pin 8)	$I_p$	typ.	35 mA
Bass boost and cut at 40 Hz (ref. 1 kHz)		typ.	$\pm 16$ dB
Treble boost and cut at 16 kHz (ref. 1 kHz)		typ.	$\pm 16$ dB
Input/output voltage at $d_{tot} = 0,7\%$ (r.m.s. value)	$V_{i,o(rms)}$	typ.	2 V
Total distortion at $V_{o(rms)} = 1$ V; linear frequency response	$d_{tot}$	typ.	0,1 %
Channel separation	$\alpha$	typ.	70 dB
Output signal plus noise voltage (r.m.s. value)	$V_{no(rms)}$	typ.	45 $\mu$ V
Frequency response ( $-1$ dB)	$f$		20 Hz to 20 kHz
Treble/bass control voltage range	$V_{12-16}; V_{4-16}$		1,8 to 9,5 V
Supply voltage range (pin 8)	$V_p$		13,5 to 16,5 V
Ambient temperature range	$T_{amb}$		$-30$ to $+80$ °C

### PACKAGE OUTLINE

16-lead DIL; plastic (SOT-38).

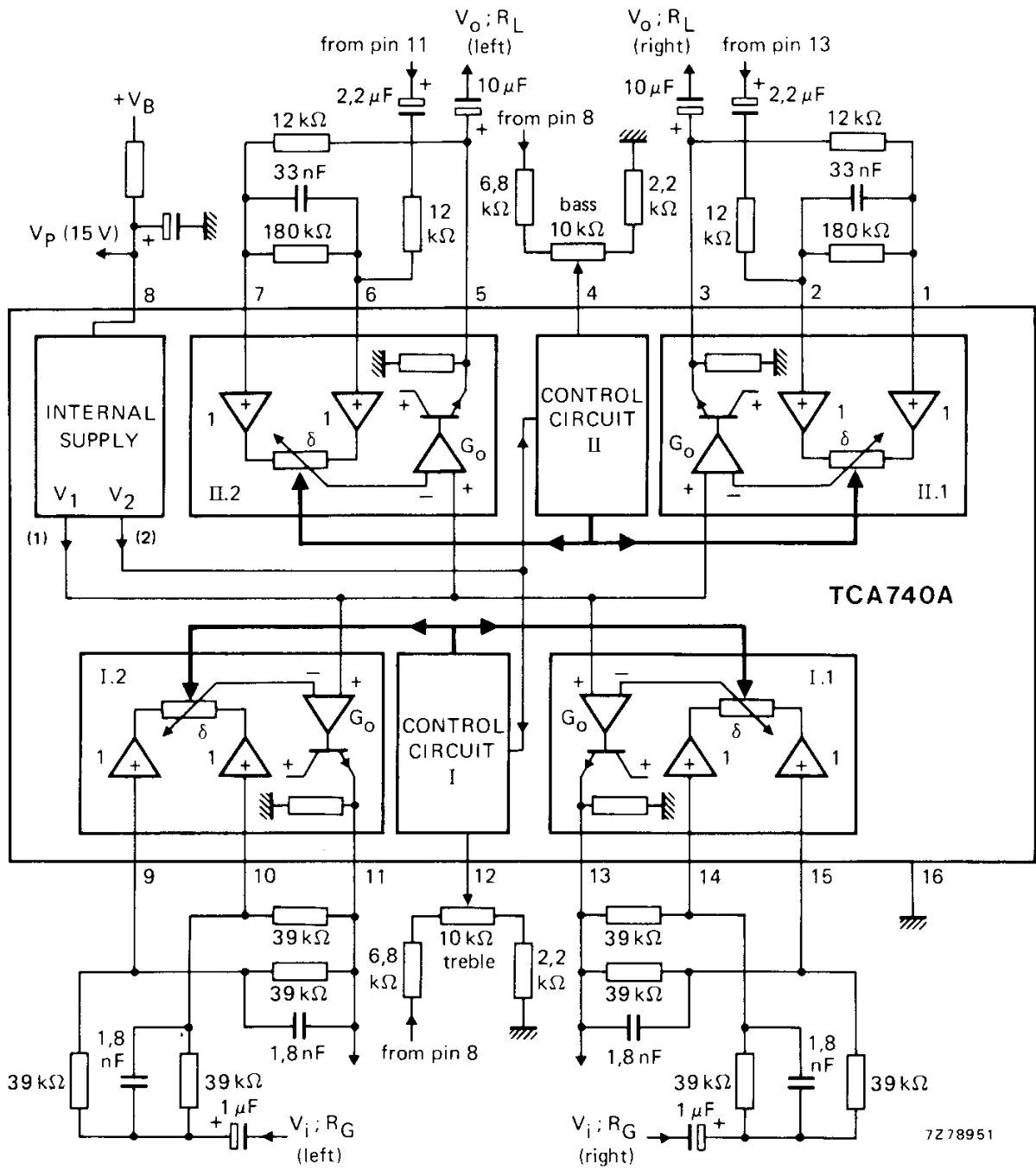

- (1)  $6,6 V_{BE}; V_1 = 4,6 V$
- (2)  $0,31 V_P + 1,4 V_{BE}; V_2 = 5,6 V$

Fig. 1 Block diagram with external circuitry.

**RATINGS**

Limiting values in accordance with the Absolute Maximum System (IEC 134)

Supply voltage (pin 8)	$V_p$	max.	18 V
Control voltages (pins 4 and 12)	$V_{4-16}$	max.	12 V
	$-V_{4-16}$	max.	5 V
	$V_{12-16}$	max.	12 V
	$-V_{12-16}$	max.	5 V
Total power dissipation	$P_{tot}$	max.	900 mW
Storage temperature range	$T_{stg}$		-55 to + 150 °C
Operating ambient temperature range	$T_{amb}$		-30 to + 80 °C

**CHARACTERISTICS**

$V_p = 15$  V;  $T_{amb} = 25$  °C; measured in Fig. 1; in position 'linear' ( $V_{4-16} = V_{12-16} = 5,6$  V);  
 $R_G = 60$   $\Omega$ ;  $R_L = 5,6$  k $\Omega$ ;  $f = 1$  kHz; unless otherwise specified

Supply voltage range (pin 8)	$V_p$		13,5 to 16,5 V
Supply current (pin 8)	$I_p$	typ.	34 mA
			25 to 45 mA
<b>Signal processing</b>			
Voltage gain at linear frequency response	$G_v$	typ.	0 dB
Frequency response (-1 dB)	$f$		20 Hz to 20 kHz
Maximum gain variation at $f = 1$ kHz at maximum bass/treble boost or cut	$\Delta G_v$	<	$\pm 1,5$ dB
Bass boost at 40 Hz (ref. 1 kHz) $V_{4-16} = 9,2$ V		>	15 dB
		typ.	16 dB
Bass cut at 40 Hz (ref. 1 kHz) $V_{4-16} = 2$ V		>	15 dB
		typ.	16 dB
Treble boost at 16 kHz (ref. 1 kHz) $V_{12-16} = 9,2$ V		>	15 dB
		typ.	16 dB
Treble cut at 16 kHz (ref. 1 kHz) $V_{12-16} = 2$ V		>	15 dB
		typ.	16 dB
<b>Total distortion</b>			
$V_{o(rms)} = 100$ mV; $f = 1$ kHz	$d_{tot}$	typ.	0,03 %
$V_{o(rms)} = 100$ mV; $f = 40$ Hz to 16 kHz	$d_{tot}$	typ.	0,1 %
$V_{o(rms)} = 1$ V; $f = 1$ kHz	$d_{tot}$	typ.	0,07 %
		<	0,2 %
$V_{o(rms)} = 1$ V; $f = 40$ Hz to 16 kHz	$d_{tot}$	typ.	0,2 %
		>	1,6 V
Input/output voltage at $d_{tot} = 0,7$ % (r.m.s. value)	$V_{i(rms)} = V_{o(rms)}$	typ.	2 V
Output signal plus noise voltage (r.m.s. value) $f = 20$ Hz to 20 kHz	$V_{no(rms)}$	typ.	40 $\mu$ V
Output noise voltage; weighted conform DIN45405; peak value	$V_{no(m)}$	typ.	90 $\mu$ V
		<	160 $\mu$ V



**CHARACTERISTICS** (continued)

Channel separation

f = 1 kHz	$\alpha$	typ.	72 dB
f = 250 Hz to 12,5 kHz	$\alpha$	typ.	68 dB
		>	50 dB
f = 40 Hz to 16 kHz	$\alpha$	typ.	58 dB

**Control voltages**

Recommended control voltage range  
treble/bass

$V_{4-16} = V_{12-16}$	>	0 V
		2 to 9,2 V
	<	0,66 $V_P$ V
	typ.	5,6 V

Control voltage at linear frequency response

$V_{4-16} = V_{12-16}$		5,4 to 5,8 V
	(0,31 $V_P$ to 1,4 $V_{BE}$ )	V

Quiescent input current

$V_{4-16} = V_{12-16} = 2$  to 9,2 V

$I_4 = I_{12}$	typ.	6 $\mu A$
	<	25 $\mu A$

Input resistance (pins 4 and 12)

$V_{4-16} = V_{12-16} = 5,6$  V

$R_{i4;12}$	typ.	800 k $\Omega$
-------------	------	----------------

**Amplifier characteristics**

Quiescent input currents;  $V_i = 4,6$  V  
(pins 1, 2, 6, 7, 9, 10, 14 and 15)

$I_1; I_2; I_6; I_7; I_9; I_{10}; I_{14}; I_{15}$	typ.	0,6 $\mu A$
	<	2 $\mu A$

Input resistance (pins 1,2,6,7,9,10,14 and 15)

$R_{i1;2;6;7;9;10;14;15}$	>	1 M $\Omega$
---------------------------	---	--------------

Internal emitter resistance at outputs

$R_{3-16}; R_{5-16}; R_{11-16}; R_{13-16}$	typ.	2 k $\Omega$
--	------	--------------

Output resistance (pins 3,5,11 and 13)

$R_{o3;5;11;13-16}$	typ.	10 $\Omega$
---------------------	------	-------------

Maximum gain; no load

$G_V$	>	40 dB
	typ.	43 dB

D.C. output voltages

$V_{4-16} = V_{12-16} = 5,6$  V (pins 3,5,11 and 13)

$V_{3-16}; V_{5-16}; V_{11-16}; V_{13-16}$	typ.	4,6 V
		4,3 to 4,9 V
		(6,6 $V_{BE}$ ) V



134

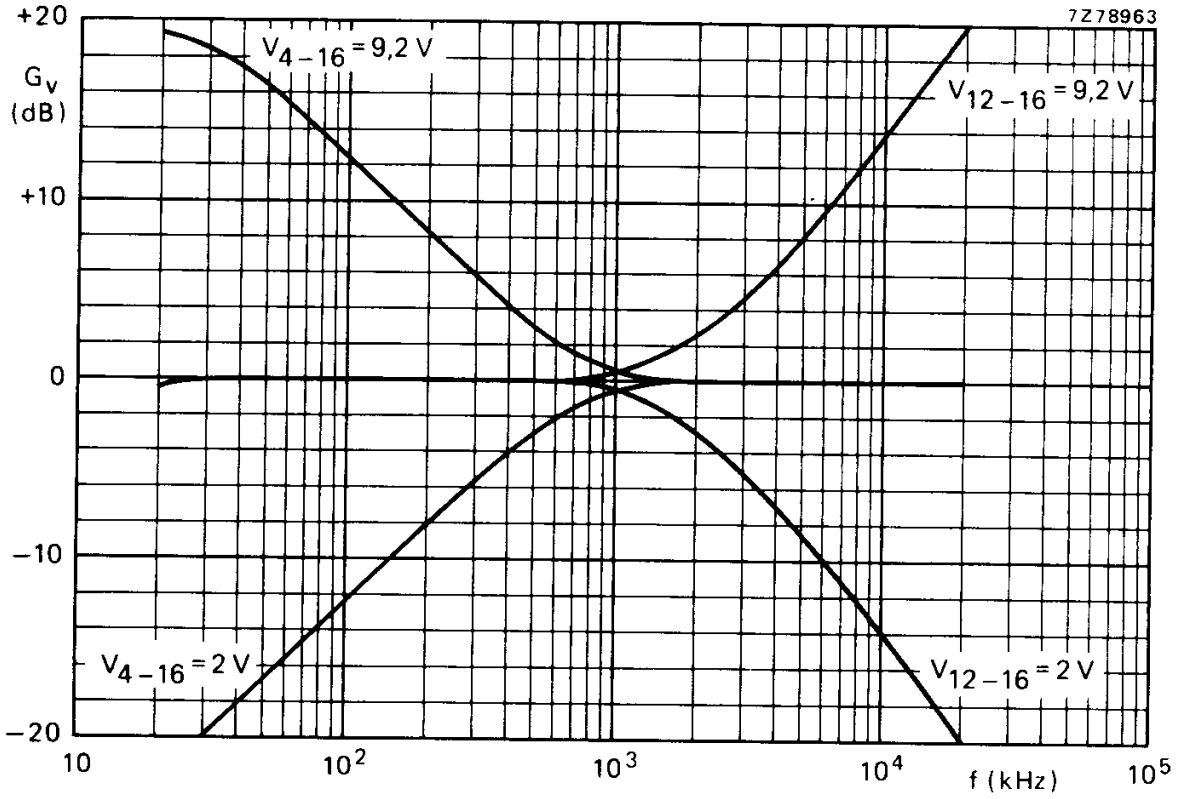

Fig. 2 Frequency response.

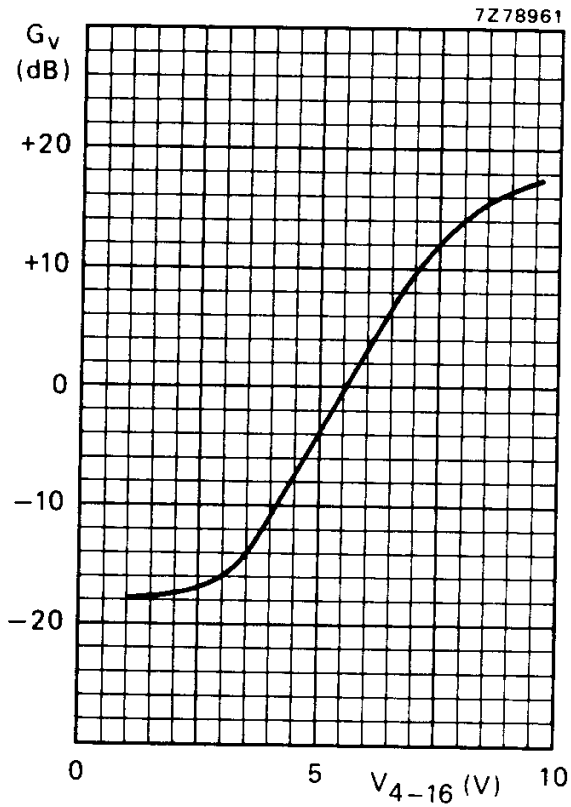

Fig. 3 Bass control curve at  $f = 40\text{ Hz}$ .

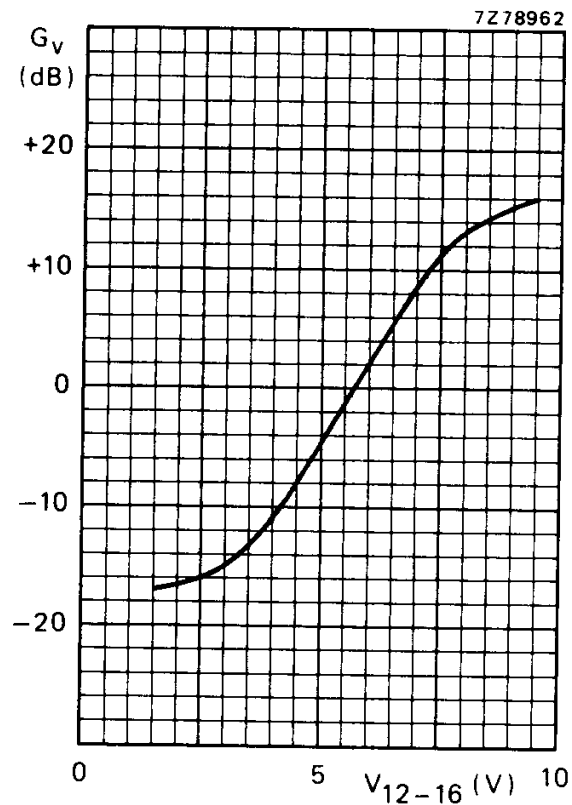

Fig. 4 Treble control curve at  $f = 16\text{ kHz}$ .

135



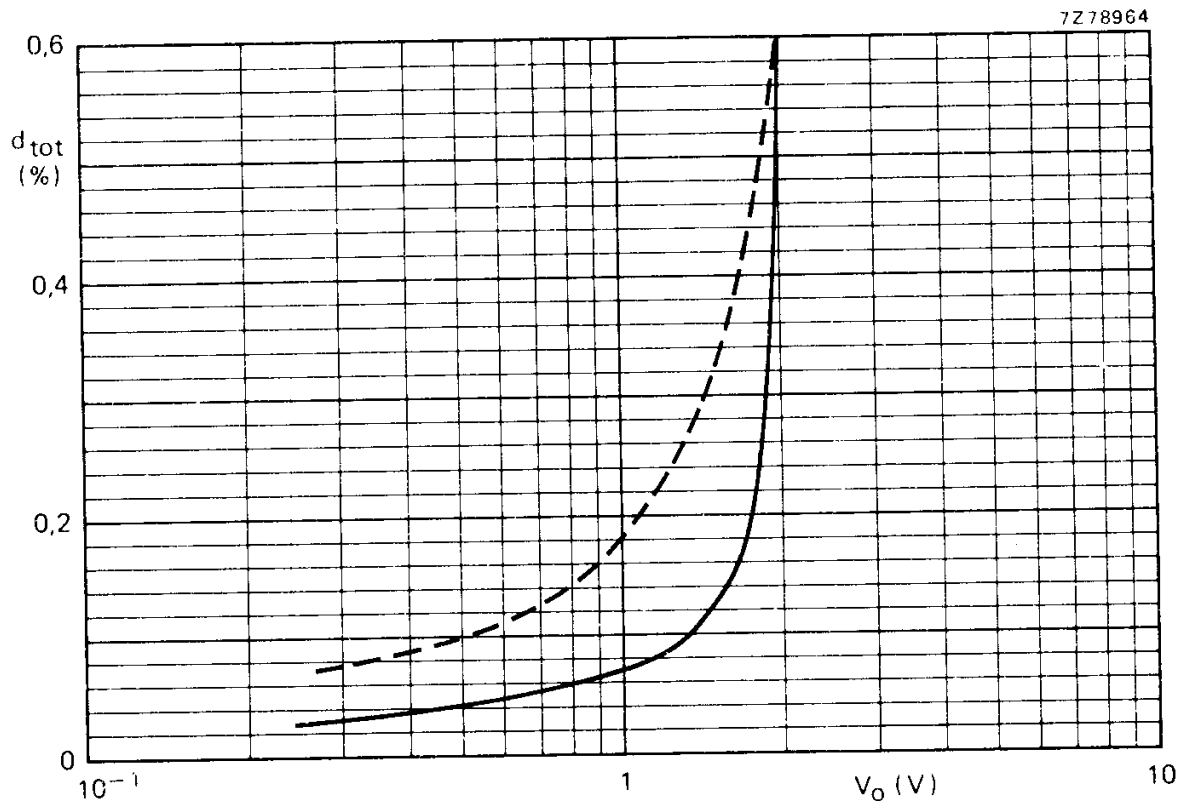
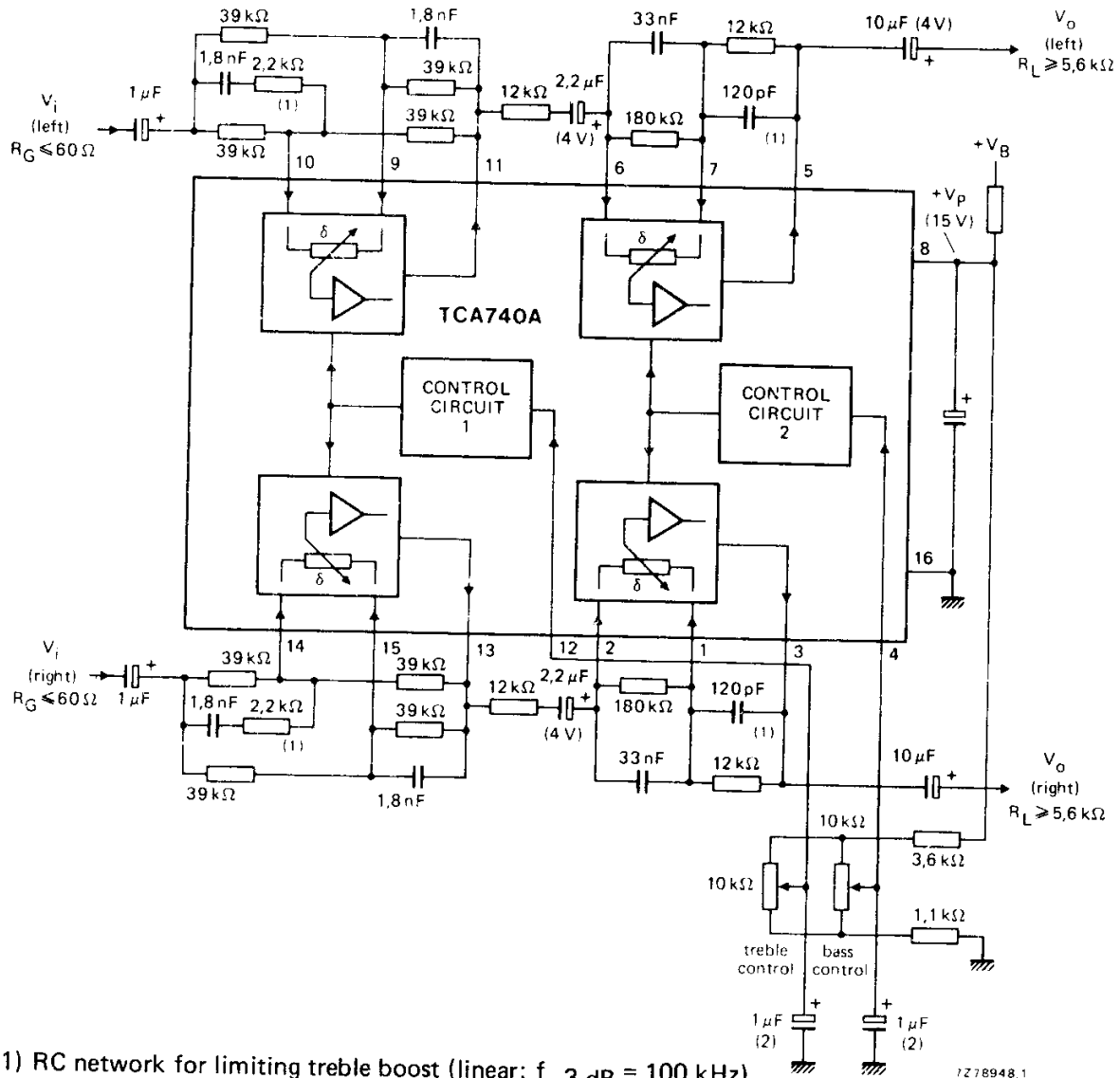

Fig. 5 Total distortion as a function of output voltage;  $V_{4-16} = V_{12-16} = 5,6$  V (linear,  $G_{V\ tot} = 1$ );  
—  $f = 1$  kHz; - - -  $f = 40$  Hz to 16 kHz.



APPLICATION INFORMATION



- (1) RC network for limiting treble boost (linear:  $f_{-3dB} = 100\text{ kHz}$ ).
- (2) Capacitors are intended for suppression of the noise when adjusting the mechanical potentiometers.

Fig. 6 Application example of TCA740A used for treble and bass control.

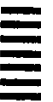

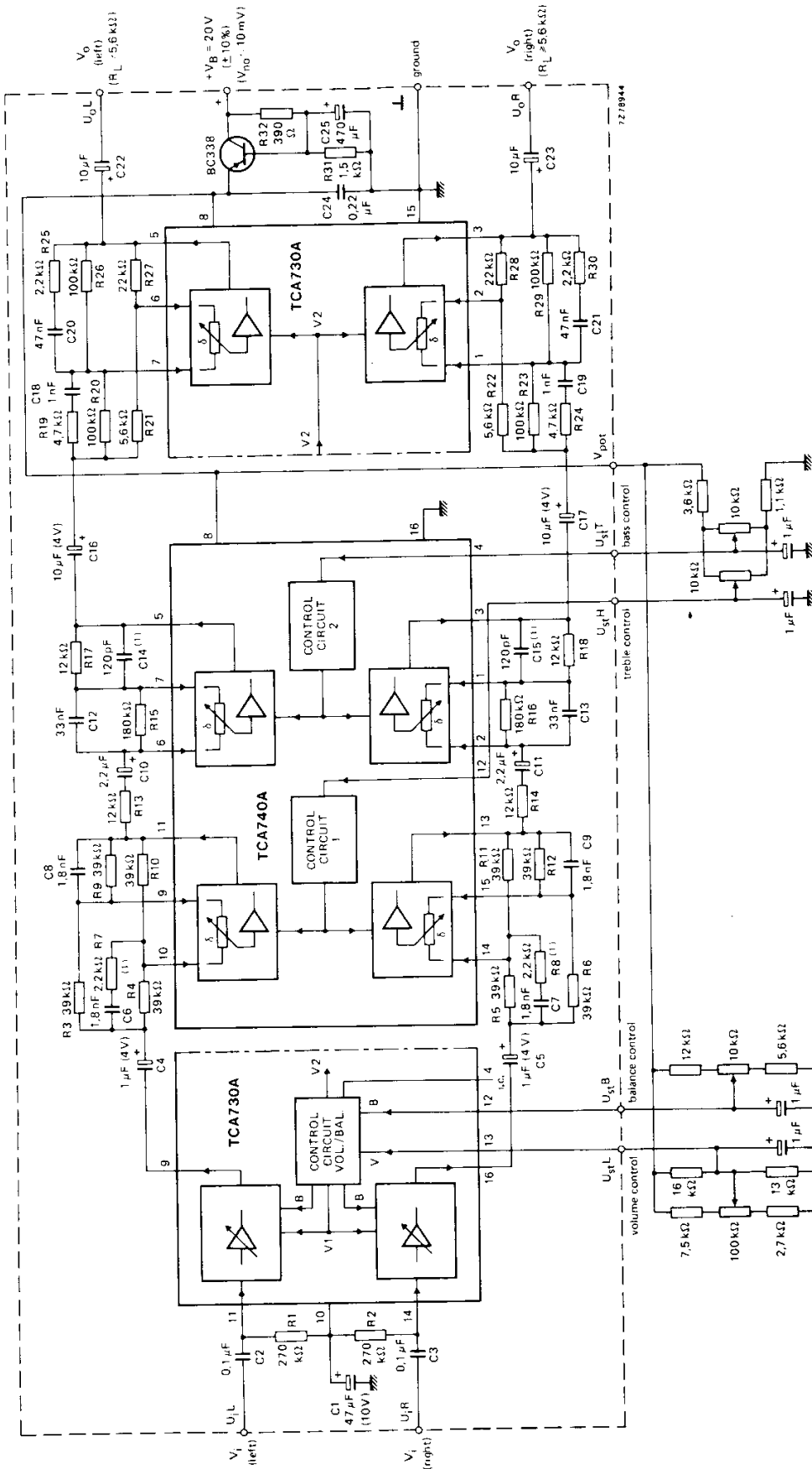

(1) RC network for limiting treble boost (linear:  $f_{-3\text{dB}} = 100\text{ kHz}$ ).

Fig. 7 Application diagram for TCA730A and TCA740A. For printed-circuit board see Fig. 8.



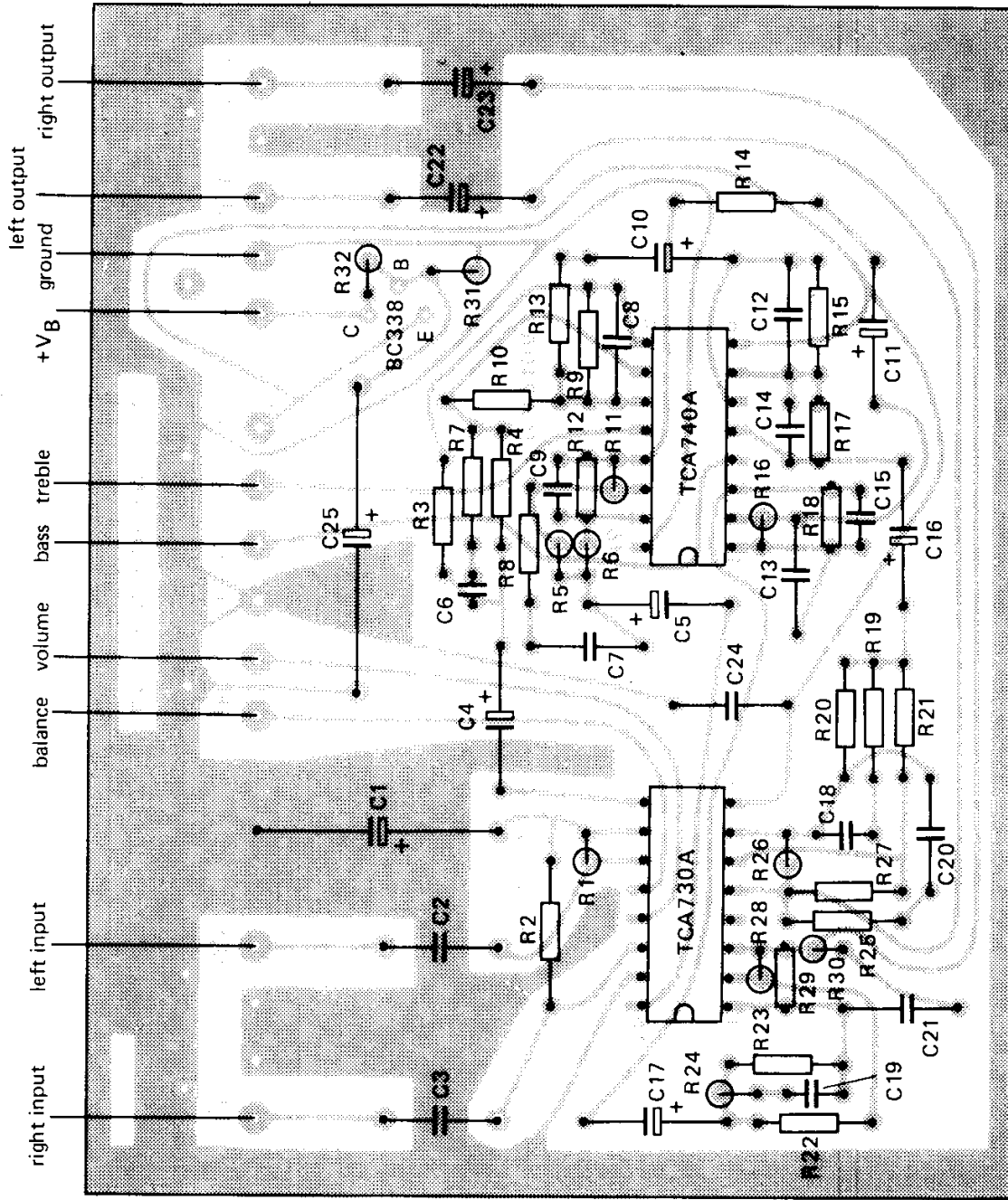

7278943

Fig. 8 Printed-circuit board component side, showing component layout; for circuit diagram see Fig. 7.

