

TOSHIBA BIPOLAR LINEAR INTEGRATED CIRCUIT SILICON MONOLITHIC

TA7291P, TA7291S, TA7291F**BRIDGE DRIVER**

The TA7291P/S/F are Bridge Driver with output voltage control.

FEATURES

- 4 modes available (CW/CCW/STOP/BRAKE)
- Output current : P type 1.0 A (AVE.) 2.0 A (PEAK)
 S/F type 0.4 A (AVE.) 1.2 A (PEAK)
- Wide range of operating voltage : $V_{CC}(\text{opr.}) = 4.5\sim 20\text{ V}$
 $V_S(\text{opr.}) = 0\sim 20\text{ V}$
 $V_{\text{ref}}(\text{opr.}) = 0\sim 20\text{ V}$
- Build in thermal shutdown, over current protector and punch = through current restriction circuit.
- Stand-by mode available (STOP MODE)
- Hysteresis for all inputs.

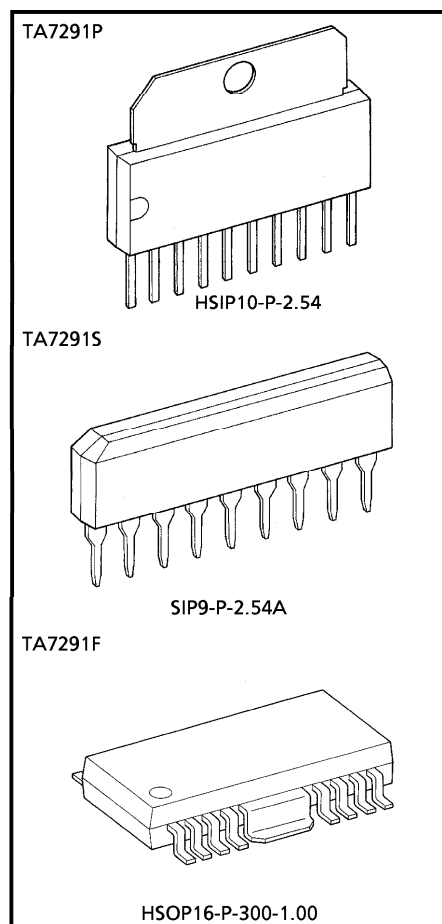

Weight	
HSIP10-P-2.54	: 2.47 g (Typ.)
SIP9-P-2.54A	: 0.92 g (Typ.)
HSOP16-P-300-1.00	: 0.50 g (Typ.)

980910EBA1

- TOSHIBA is continually working to improve the quality and the reliability of its products. Nevertheless, semiconductor devices in general can malfunction or fail due to their inherent electrical sensitivity and vulnerability to physical stress. It is the responsibility of the buyer, when utilizing TOSHIBA products, to observe standards of safety, and to avoid situations in which a malfunction or failure of a TOSHIBA product could cause loss of human life, bodily injury or damage to property. In developing your designs, please ensure that TOSHIBA products are used within specified operating ranges as set forth in the most recent products specifications. Also, please keep in mind the precautions and conditions set forth in the TOSHIBA Semiconductor Reliability Handbook.
- The products described in this document are subject to the foreign exchange and foreign trade laws.
- The information contained herein is presented only as a guide for the applications of our products. No responsibility is assumed by TOSHIBA CORPORATION for any infringements of intellectual property or other rights of the third parties which may result from its use. No license is granted by implication or otherwise under any intellectual property or other rights of TOSHIBA CORPORATION or others.
- The information contained herein is subject to change without notice.

BLOCK DIAGRAM

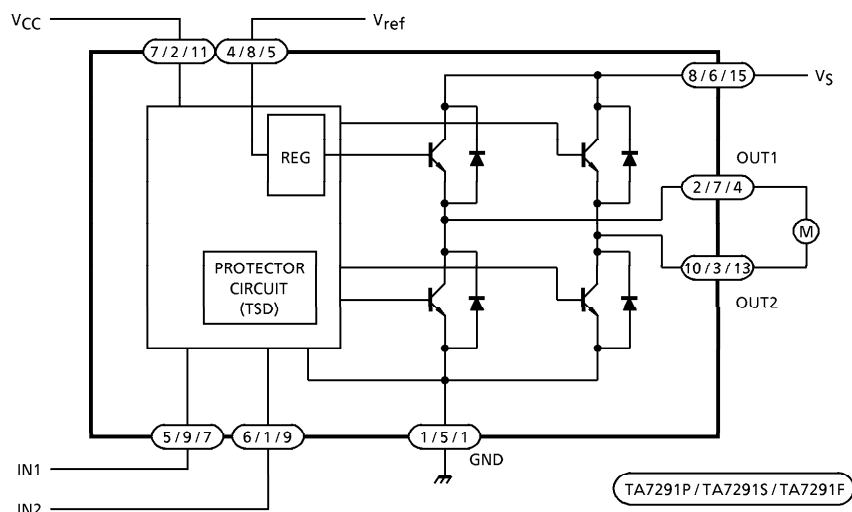

PIN FUNCTION

PIN No.			SYMBOL	FUNCTIONAL DESCRIPTION
P	S	F		
7	2	11	V _{CC}	Supply voltage terminal for Logic
8	6	15	V _S	Supply voltage terminal for Motor driver
4	8	5	V _{ref}	Supply voltage terminal for control
1	5	1	GND	GND terminal
5	9	7	IN1	Input terminal
6	1	9	IN2	Input terminal
2	7	4	OUT1	Output terminal
10	3	13	OUT2	Output terminal

P Type : PIN ③, ⑨ : NC

S Type : PIN ④ : NC

F Type : PIN ②, ③, ⑥, ⑧, ⑩, ⑫, ⑭, and ⑯ : NC

For F Type, We recommend FIN to be connected to the GND.

FUNCTION

INPUT		OUTPUT		MODE
IN1	IN2	OUT1	OUT2	
0	0	∞	∞	STOP
1	0	H	L	CW / CCW
0	1	L	H	CCW / CW
1	1	L	L	BRAKE

∞ : High impedance

(Note) Inputs are all high active type

MAXIMUM RATINGS (Ta = 25°C)

CHARACTERISTIC		SYMBOL	RATING	UNIT
Supply Voltage		V _{CC}	25	V
Motor Drive Voltage		V _S	25	V
Reference Voltage		V _{ref}	25	V
Output Current	PEAK	P Type	2.0	A
		S/F Type	1.2	
	AVE.	P Type	1.0	
		S/F Type	0.4	
Power Dissipation	P Type	P _D	(*1) 12.5	W
	S Type		(*2) 0.95	
	F Type		(*3) 1.4	
Operating Temperature		T _{opr}	-30~75	°C
Storage Temperature		T _{stg}	-55~150	°C

(*1) T_c = 25°C (TA7291P)

(*2) No heat sink

(*3) PCB (60 × 30 × 1.6 mm, occupied copper area in excess of 50%) Mounting Condition.

Wide range of operating voltage : V_{CC} (opr.) = 4.5~20 V

V_S (opr.) = 0~20 V

V_{ref} (opr.) = 0~20 V

V_{ref} ≤ V_S

ELECTRICAL CHARACTERISTICS (Unless otherwise specified, Ta = 25°C, VCC = 12 V, VS = 18 V)

CHARACTERISTIC		SYMBOL	TEST CIRCUIT	TEST CONDITION	MIN.	TYP.	MAX.	UNIT
Supply Current		ICC1	1	Output OFF, CW/CCW mode	—	8.0	13.0	mA
		ICC2		Output OFF, Stop mode	—	0	50	μA
		ICC3		Output OFF, Brake mode	—	6.5	10.0	mA
Input Operating Voltage	1 (High)	VIN1	2	Tj = 25°C	3.5	—	5.5	V
	2 (Low)	VIN2			GND	—	0.8	
Input Current		IIN		VIN = 3.5 V, Sink mode	—	3	10	μA
Input Hysteresis Voltage		ΔVT		—	—	0.7	—	V
Saturation Voltage	P/S/F Type	Upper Side	3	Vref = VS, VOUT - VS measure IO = 0.2 A, CW/CCW mode	—	0.9	1.2	V
		Lower Side		Vref = VS, VOUT - GND measure IO = 0.2 A, CW/CCW mode	—	0.8	1.2	
	S/F Type	Upper Side		Vref = VS, VOUT - VS measure IO = 0.4 A, CW/CCW mode	—	1.0	1.35	
		Lower Side		Vref = VS, VOUT - GND measure IO = 0.4 A, CW/CCW mode	—	0.9	1.35	
	P Type	Upper Side		Vref = VS, VOUT - VS measure IO = 1.0 A, CW/CCW mode	—	1.3	1.8	
		Lower Side		Vref = VS, VOUT - GND measure IO = 1.0 A, CW/CCW mode	—	1.2	1.85	
Output Voltage (Upper Side)	S/F Type	VSAT U-1'	3	Vref = 10 V, VOUT - GND measure, IO = 0.2 A, CW/CCW mode	—	11.2	—	V
		VSAT U-2'		Vref = 10 V, VOUT - GND measure, IO = 0.4 A, CW/CCW mode	10.4	10.9	12.2	
	P Type	VSAT U-3'		Vref = 10 V, VOUT - GND measure, IO = 0.5 A, CW/CCW mode	—	11.0	—	
		VSAT U-4'		Vref = 10 V, VOUT - GND measure, IO = 1.0 A, CW/CCW mode	10.2	10.7	12.0	
Leakage Current		Upper Side	4	VL = 25 V	—	—	50	μA
		Lower Side		VL = 25 V	—	—	50	
Diode Forward Voltage	S/F Type	Upper Side	5	IF = 0.4 A	—	1.5	—	V
	P Type	Lower Side		IF = 1 A	—	2.5	—	
	S/F Type	Upper Side		IF = 0.4 A	—	0.9	—	
	P Type	Lower Side		IF = 1 A	—	1.2	—	
Reference Current		Iref	2	Vref = 10 V, Source mode	—	20	40	μA

TEST CIRCUIT 1

I_{CC1} , I_{CC2} , I_{CC3}

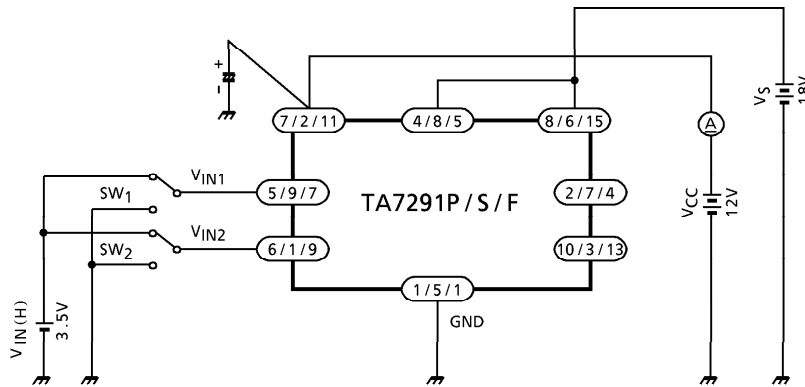

(Note) HEAT FIN of TA7291P is connected to GND.

TEST CIRCUIT 2

V_{IN1} , V_{IN2} , I_{IN} , ΔV_T , I_{ref}

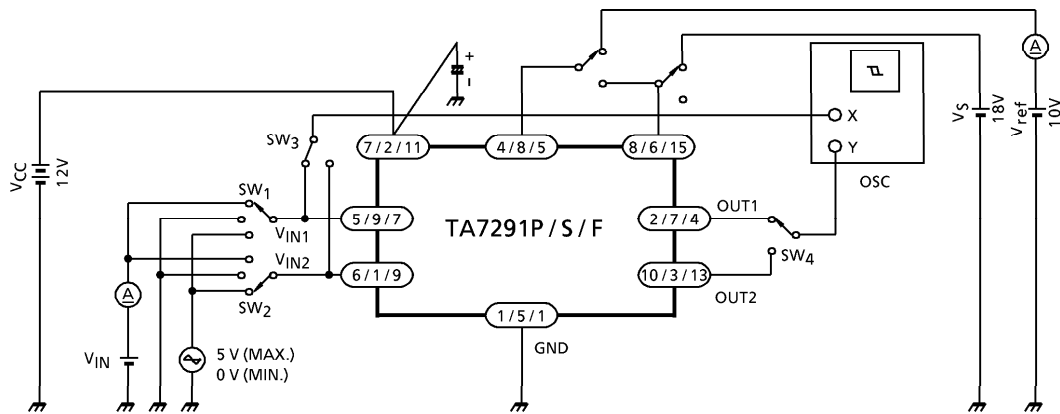

TA7291P / TA7291S / TA7291F

(Note) HEAT FIN of TA7291F is connected to GND.

TEST CIRCUIT 3

$V_{SATU-1, 2, 3}$ $V_{SATL-1, 2, 3}$ $V_{SATU-1', 2', 3', 4'}$

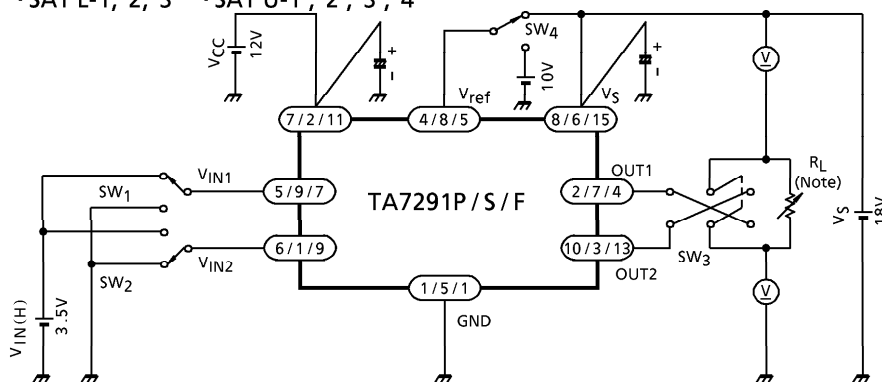

(Note) I_{OUT} calibration is required to adjust specified values of test conditions by R_L .
 ($I_{OUT} = 0.2\text{ A} / 0.4\text{ A} / 0.5\text{ A} / 1.0\text{ A}$)

(Note) HEAT FIN of TA7291F is connected to GND.

TEST CIRCUIT 4

$I_{LU, L}$

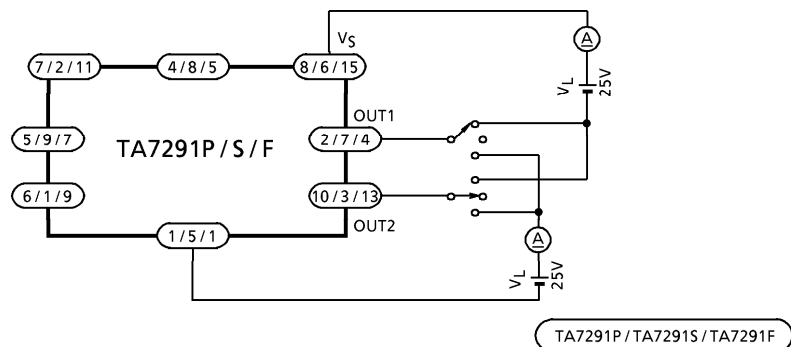

(Note) HEAT FIN of TA7291F is connected to GND.

TEST CIRCUIT 5

$V_{FU-1, 2}$ $V_{FL-1, 2}$

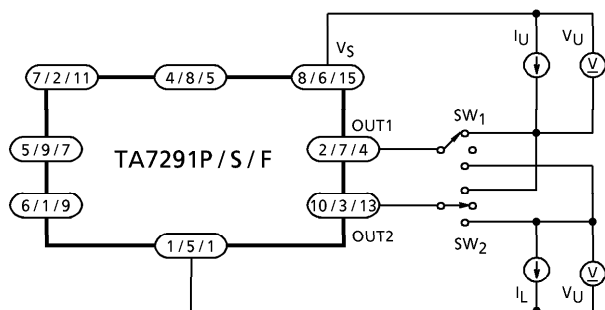

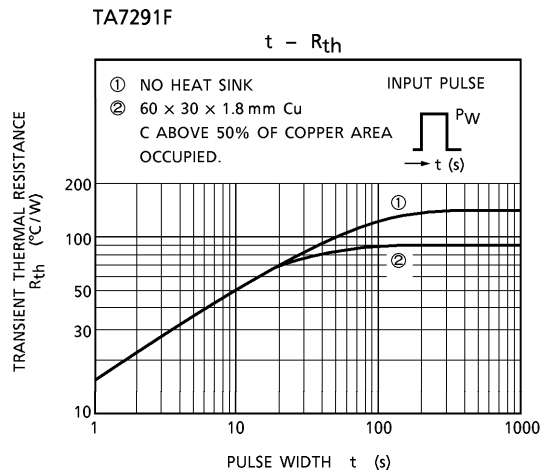
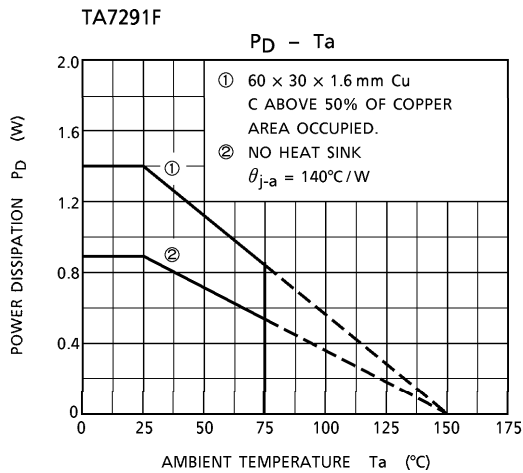
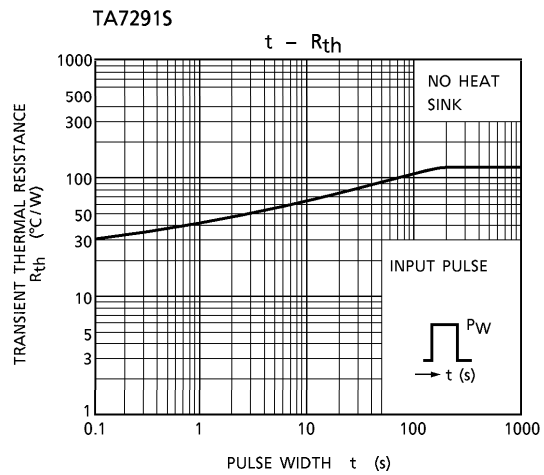
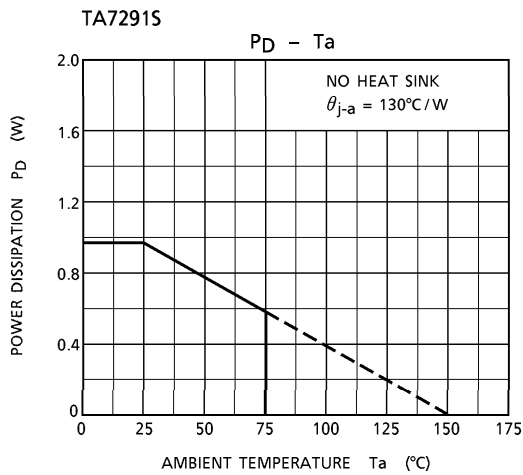
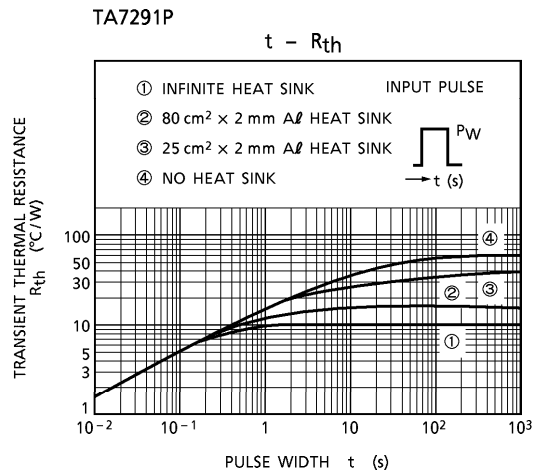
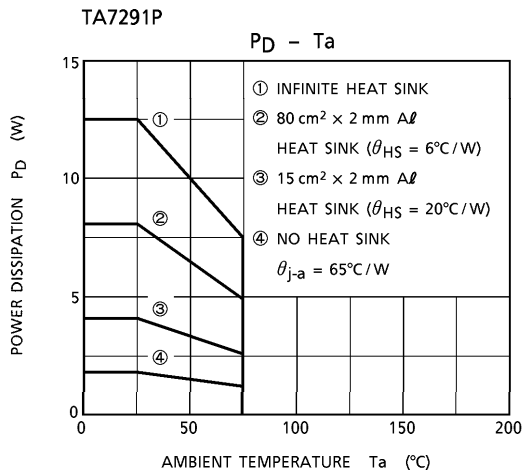

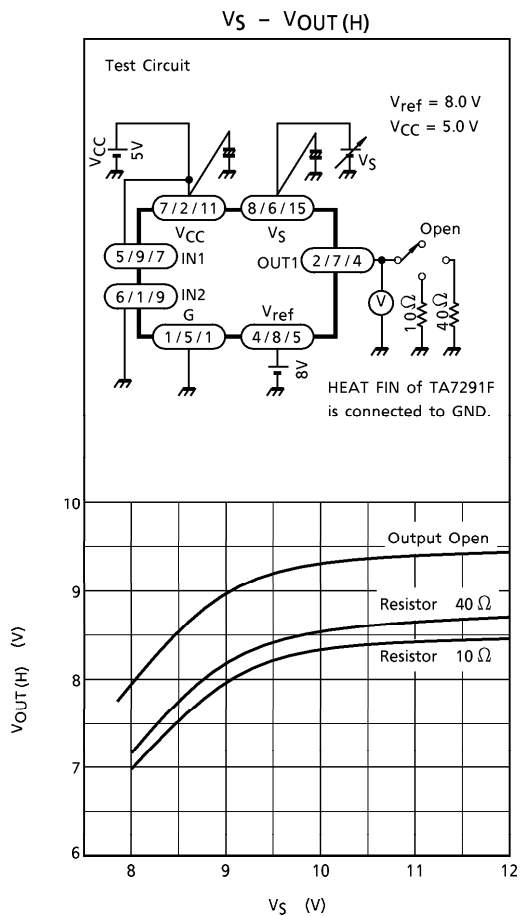
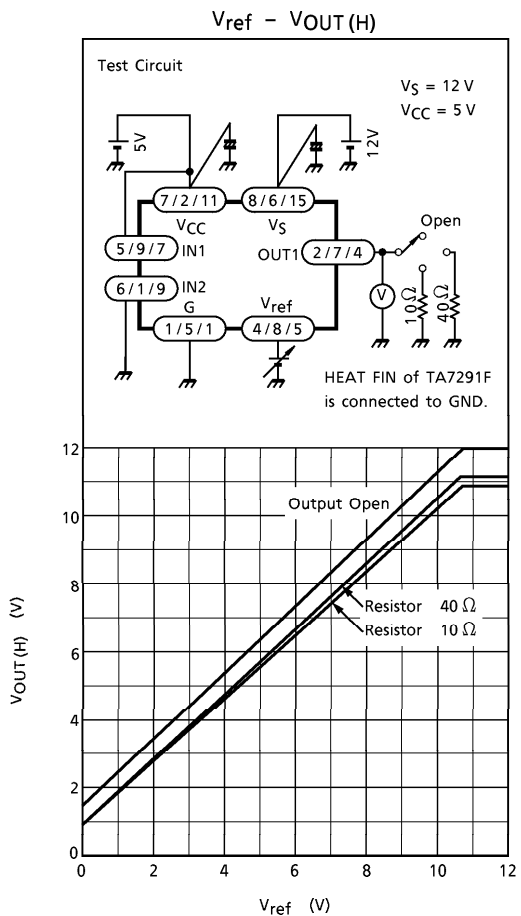
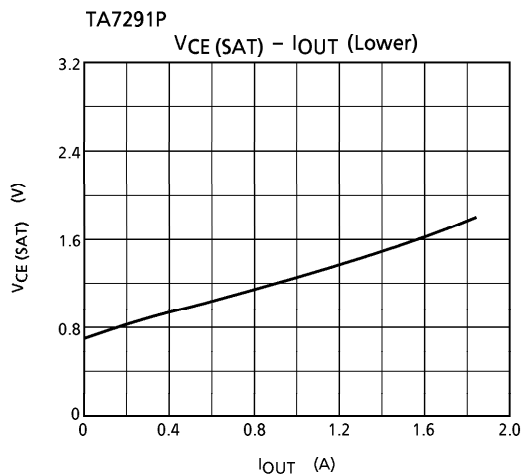
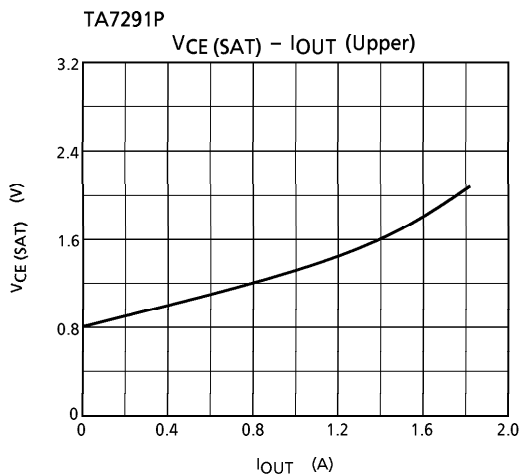

NOTES

Input circuit

Input Terminals of pin ⑤ and ⑥ (TA7291P) are all high active type and have a hysteresis of 0.7 V (typ.), 3 μA (typ.) of source mode input current is required.

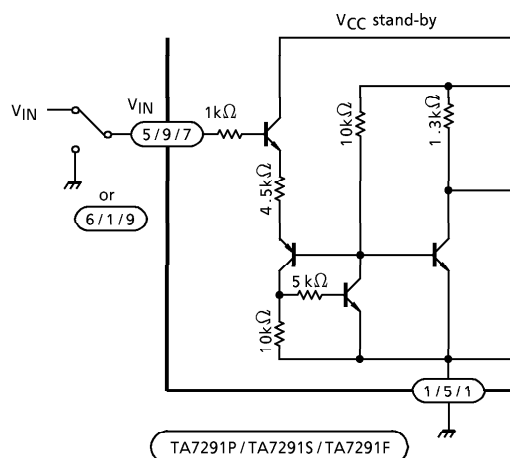

Output circuit

Output voltage is controlled by V_{ref} voltage.

Relationship between V_{OUT} and V_{ref} is

$$V_{OUT} = V_{BE} (\cong 0.7) + V_{ref}$$

V_{ref} terminal required to connect to V_S terminal for stable operation in case of no requirement of

V_{OUT} control.

$$V_{ref} \leq V_S$$

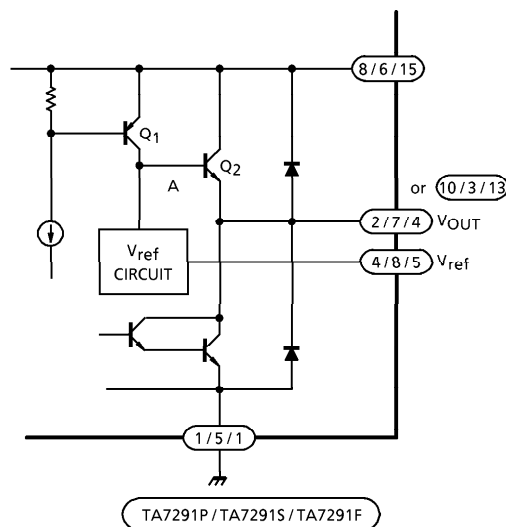

APPLICATION CIRCUIT

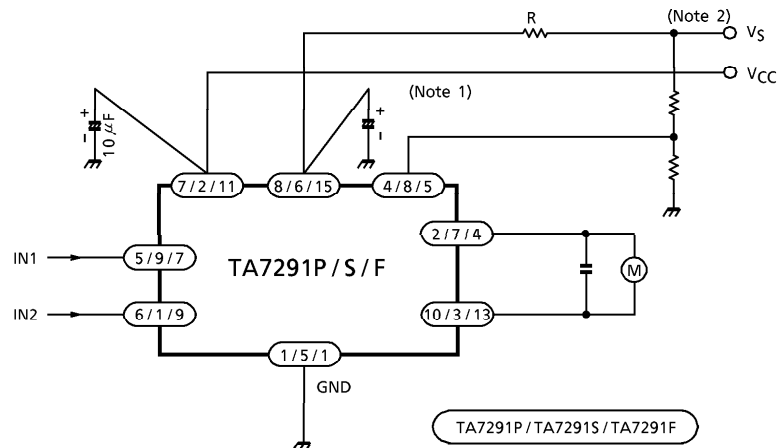

(Note 1) Experiment to find the optimum capacitor value.

(Note 2) To protect against excess current, current limitation resistor R should be inserted where necessary.

NOTES

- Be careful when switching the input because rush current may occur.
When switching, stop mode should be entered or current limitation resistor R should be inserted.
- The IC functions cannot be guaranteed when turning power on or off.
Before using the IC for application, check that there are no problems.
- Utmost care is necessary in the design of the output line, V_S , V_{CC} and GND line since IC may be destroyed due to short-circuit between outputs, air contamination fault, or fault by improper grounding.

OUTLINE DRAWING
HSIP10-P-2.54

Unit : mm

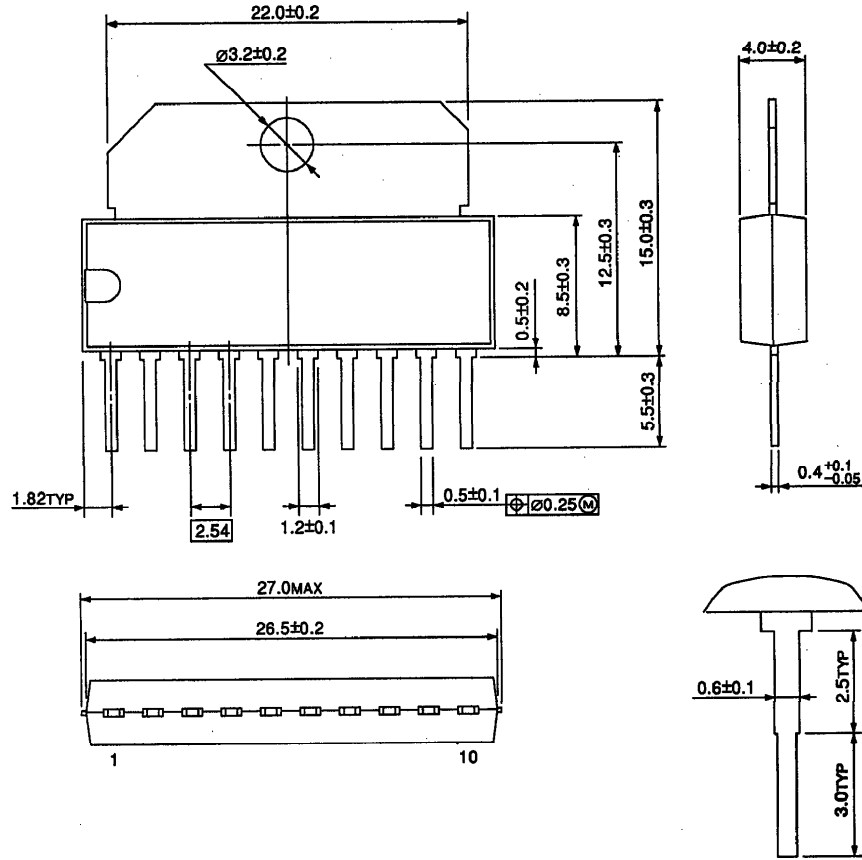

Weight : 2.47 g (Typ.)

OUTLINE DRAWING
SIP9-P-2.54A

Unit : mm

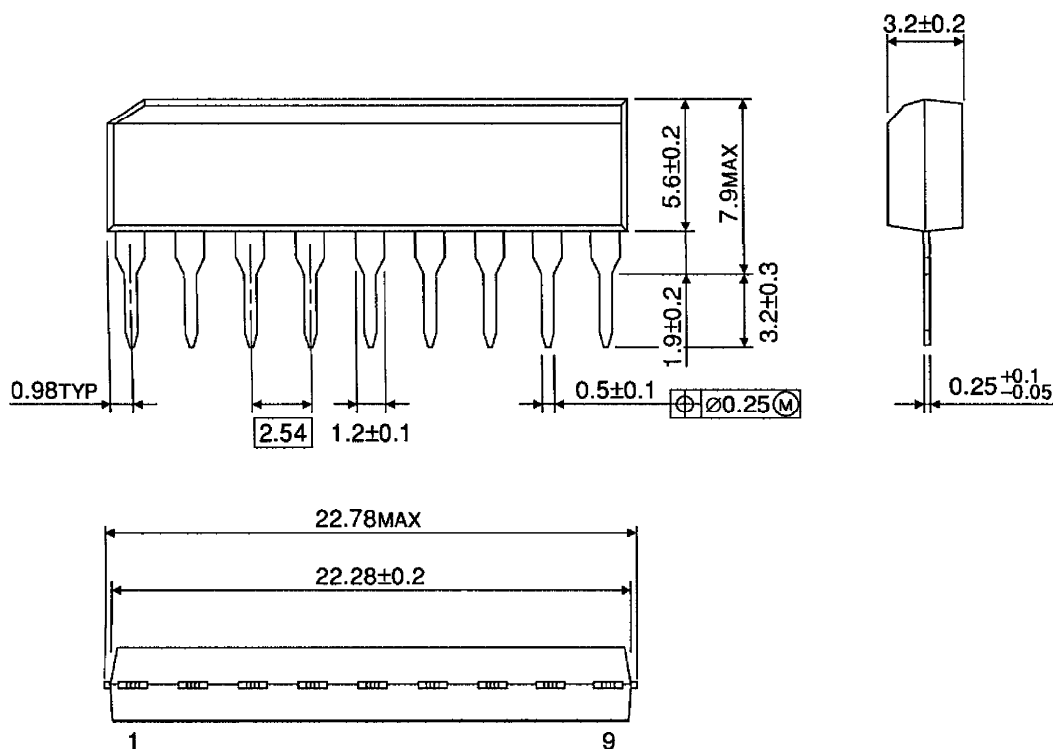

Weight : 0.92 g (Typ.)

OUTLINE DRAWING
HSOP16-P-300-1.00

Unit : mm

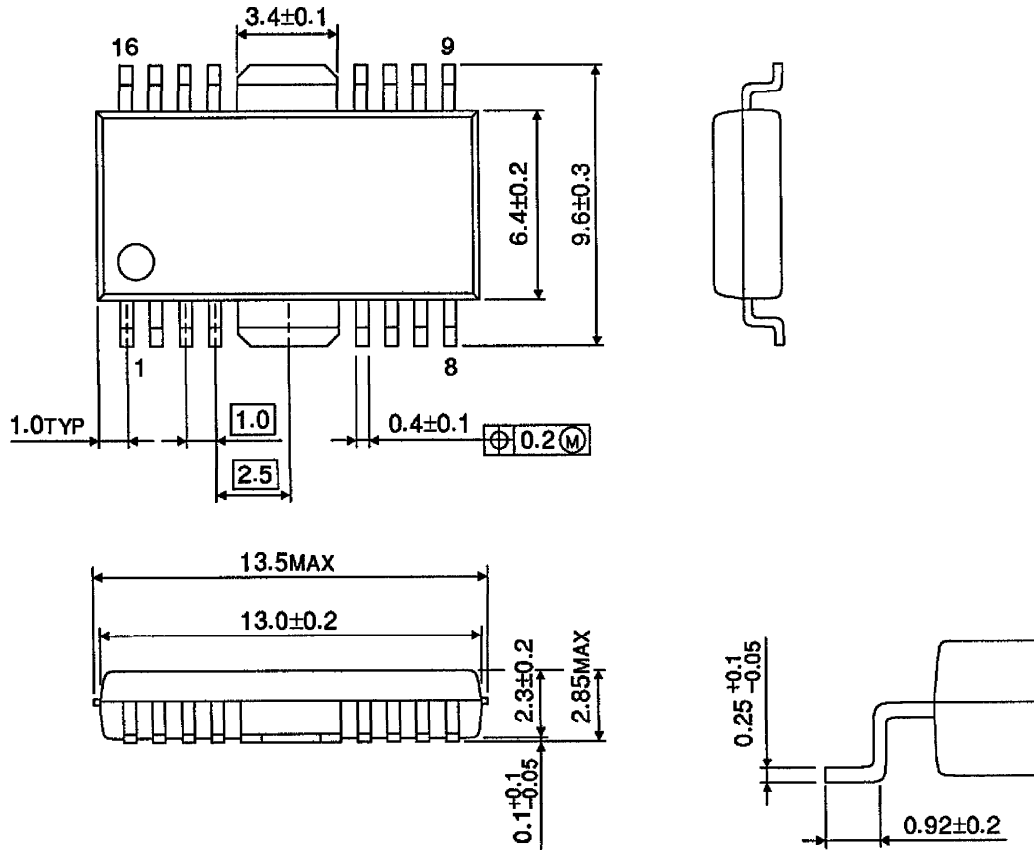

Weight : 0.50 g (Typ.)