

MITSUBISHI (DGTL LOGIC)

M54548AL**BI-DIRECTIONAL MOTOR DRIVER WITH MOTOR SPEED CONTROL****DESCRIPTION**

The M54548AL, BI-DIRECTIONAL MOTOR DRIVER, consists of a full bridge power driver designed for use in a D-C motor control circuit. The internal operational amplifier is capable for controlling the voltage across the bridge outputs.

FEATURES

- Wide operating voltage range
- NMOS and CMOS compatible input
- 1.2A output current
- Integral operational amplifier for output source voltage
- Integral diodes for transient suppression
- Braking mode input
- 12pin shrink single inline package with heat sink

APPLICATION

Audio, video cassette recorder

FUNCTION

The M54548AL, full bridge motor driver, has the logic circuitry and the quasi-darlington power driver for bidirectional control of D-C motors operating at current up to 1.2A. The inputs, S_1 , S_2 and S_3 , are capable to control the bridge output polarity and also to select the supply voltage of the pre-driver from the voltages driven by V_1 , V_2 or the output of the operational amplifier.

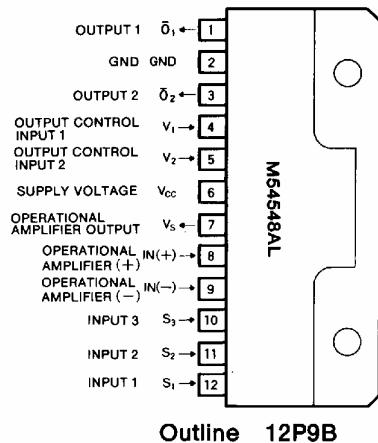
PIN CONFIGURATION (TOP VIEW)**LOGIC TRUTH TABLE**

Inputs			Output		Driver power supply	Note
S_1	S_2	S_3	\bar{O}_1	\bar{O}_2	(V_{cc})	
L	L	L	"OFF" state	"OFF" state	—	STOP
L	L	H	H	L	OP-AMP OUTPUT	PLAY(+)
L	H	L	L	H	OP-AMP OUTPUT	PLAY(-)
L	H	H	H	L	V_2	FF(2)
H	L	L	L	H	V_2	REW(2)
H	L	H	H	L	V_1	FF(1)
H	H	L	L	H	V_1	REW(1)
H	H	H	L	L	V_s	BRAKING

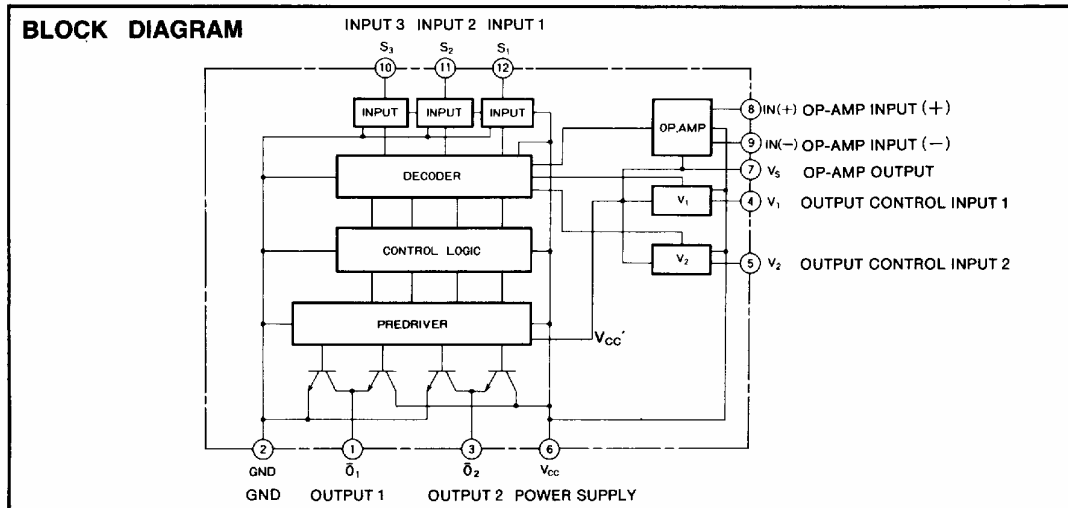

BI-DIRECTIONAL MOTOR DRIVER WITH MOTOR SPEED CONTROL

ABSOLUTE MAXIMUM RATINGS (T_a=25°C, unless otherwise noted)

Symbol	Parameter	Conditions	Ratings	Unit
V _{CC}	Supply voltage	With external heat sink (3000mm ² ×1.5mm ²)	-0.5~+18	V
V _I	Input voltage	4Pin, 5Pin	-0.5~+14 or V _{CC}	V
		Other input pins	-0.5~V _{CC}	
V _O	Output voltage		-0.5~V _{CC} +2.5	V
I _{O(max)}	Allowable motor charge current	t _{op} = 10ms; Repetitive cycle 0.2 Hz max	±1.2	A
I _{O(1)}	Continuous output current (1)		±300	mA
I _{O(2)}	Continuous output current (2)	With an external heat sink (3000mm ² ×1.5mm ²)	±600	mA
P _d	Power dissipation	T _a = 75°C	1.1	W
T _{opr}	Operating temperature		-10~+75	°C
T _{stg}	Storage temperature		-55~+125	°C

RECOMMENDED OPERATING CONDITIONS (T_a=-25°C, unless otherwise noted)

Symbol	Parameter	Conditions	Limits			Unit
			Min	Typ	Max	
V _{CC}	Supply voltage		4	12	16	V
I _O	Output current				±200	mA
V _{IH}	High-level input voltage		3			V
V _{IL}	Low-level input voltage				1	V
t _B	Motor braking interval		10	100		ms

ELECTRICAL CHARACTERISTICS (T_a=25°C, unless otherwise noted)

Symbol	Parameter	Test conditions		Limits			Unit
				Min	Typ	Max	
I _{O (leak)}	Output leakage current	V _{S1} =0V V _{S2} =0V V _{S3} =0V	V _O =0V			-100	μA
			V _{CC} =V _S =20V V _O =14V V _{CC} =V _S =14V			+100	
V _{O(H)1}	High-level output saturation voltage (1)	V _{CC} =16V V _{IN(-)}} =0V V _{IN(+)} =3V	V _{S1} =V _{S2} =0V V _{S3} =3V	I _{OH} =-200mA	13		V
				I _{OH} =-500mA	12.8		
V _{O(H)2}	High-level output saturation voltage (2)	V _{CC} =16V V _{IN(-)}} =0V V _{IN(+)} =3V	V _{S1} =V _{S2} =0V V _{S3} =3V	I _{OH} =-200mA	13		V
				I _{OH} =-500mA	12.8		
V _{O(L)1}	Low-level output saturation voltage (1)	V _{CC} =16V V _{IN(-)}} =0V V _{IN(+)} =3V	V _{S1} =V _{S2} =0V V _{S3} =3V	I _{OL} =200mA		0.5	V
				I _{OL} =500mA		1.4	
V _{O(L)2}	Low-level output saturation voltage (2)	V _{CC} =16V V _{IN(-)}} =0V V _{IN(+)} =3V	V _{S1} =V _{S2} =0V V _{S3} =3V	I _{OL} =200mA		0.5	V
				I _{OL} =500mA		1.4	
I _{IH}	High-level input current	V _{CC} =16V, V _{I5} =3V (S ₁ , S ₂ , S ₃)				10	μA
I _{IL}	Low-level input current	V _{CC} =16V, V _{I5} =0V (S ₁ , S ₂ , S ₃)				-20	μA
I _{CC}	Supply current	V _{CC} =16V, V _{S1} =V _{S2} =V _{S3} =3V				30	mA
A	Op-amp open loop gain			50			dB

BI-DIRECTIONAL MOTOR DRIVER WITH MOTOR SPEED CONTROL

TYPICAL CHARACTERISTICS

ALLOWABLE AVERAGE POWER DISSIPATION

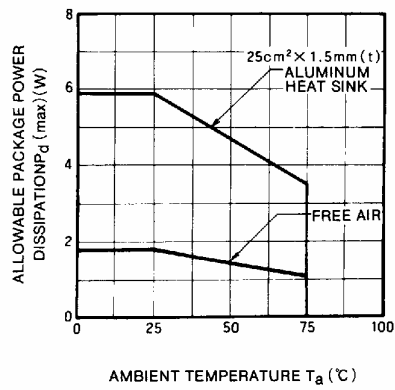

APPLICATION EXAMPLE

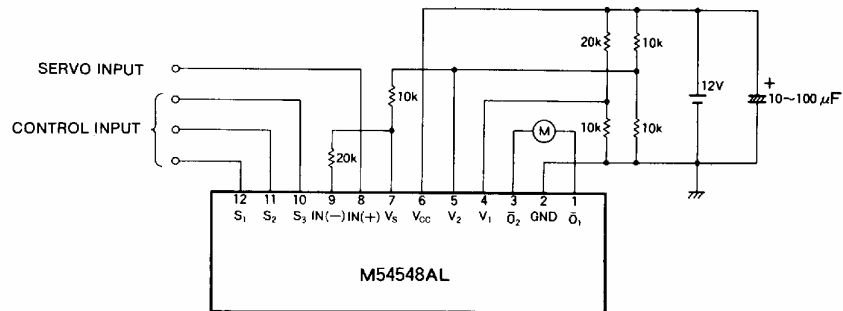

Unit : Ω