

KA317M

3-Terminal 0.5A Positive Adjustable Regulator

Features

- Output Current in Excess of 0.5A
- Output Adjustable Between 1.2V and 37V
- Internal Thermal Overload Protection
- Internal Short Circuit Current Limiting
- Output Transistor Safe Area Compensation
- Floating Operation for High Voltage Applications

Description

The KA317M is a 3-Terminal adjustable positive voltage regulator capable of supplying in excess of 500mA over an output voltage range of 1.2V to 37V. This voltage regulator is exceptionally easy to use and requires only two external resistors to set the output voltage.

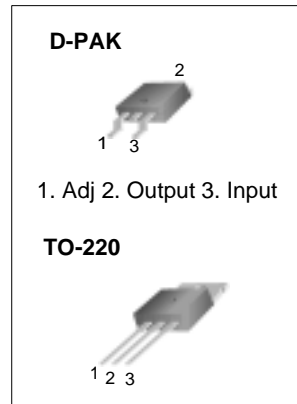

Internal Block Diagram

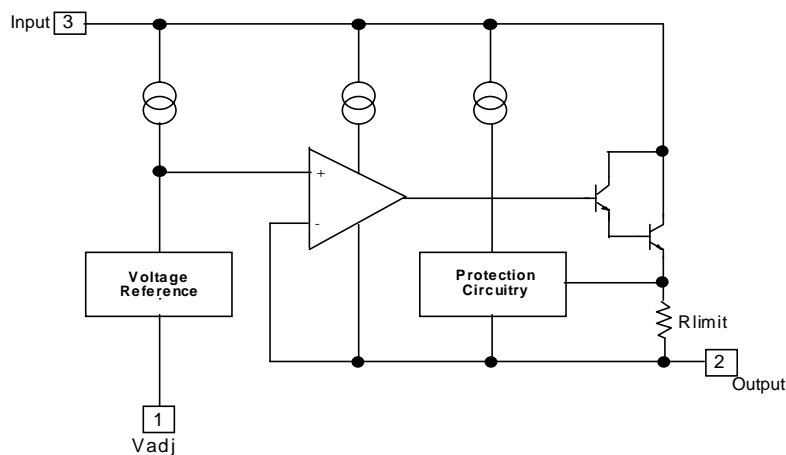

Absolute Maximum Ratings

Parameter	Symbol	Value	Unit
Input Output Voltage Differential	$V_I - V_O$	40	V
Power Dissipation	P_D	Internally limited	W
Thermal Resistance Junction-Air D-PAK (Note1,2)	$R_{\theta JA}$	100	$^{\circ}C/W$
Operating Junction Temperature Range	T_j	0 ~ +125	$^{\circ}C$
Storage Temperature Range	T_{STG}	-65 ~ +125	$^{\circ}C$

Electrical Characteristics

($V_I - V_O = 5V$, $I_O = 0.1A$, $0^{\circ}C \leq T_J \leq +125^{\circ}C$, $P_{DMAX} = 7.5W$, unless otherwise specified)

Parameter	Symbol	Conditions	Min.	Typ.	Max.	Unit
Line Regulation (Note3)	Rline	$T_A = +25^{\circ}C$, $3V \leq V_I - V_O \leq 40V$	-	0.01	0.04	% / V
		$3V \leq V_I - V_O \leq 40V$	-	0.02	0.07	
Load Regulation (Note3)	Rload	$T_A = +25^{\circ}C$, $10mA \leq I_O \leq 0.5A$ $V_O \leq 5V$ $V_O \geq 5V$	-	5 0.1	25 0.5	mV % / V_O
		$10mA \leq I_O \leq 0.5A$ $V_O \leq 5V$ $V_O \geq 5V$	-	20 0.3	70 1.5	mV % / V_O
Adjustment Pin Current	I_{ADJ}	-	-	50	100	μA
Adjustment Pin Current Change	ΔI_{ADJ}	$3V \leq V_I - V_O \leq 40V$ $10mA \leq I_O \leq 0.5A$, $P_D < P_{DMAX}$	-	0.2	5	μA
Reference Voltage	V_{REF}	$3V < V_I - V_O < 40V$ $10mA \leq I_O \leq 0.5A$, $P_D < P_{DMAX}$	1.20	1.25	1.30	V
Temperature Stability	ST_T	-	-	0.7	-	% / V_O
Minimum Load Current to Maintain Regulation	$I_{L(MIN)}$	$V_I - V_O = 40V$	-	3.5	10	mA
Maximum Output Current	$I_{O(MAX)}$	$V_I - V_O \leq 15V$, $P_D < P_{DMAX}$	0.5	0.9	-	A
		$V_I - V_O = 40V$ $P_D < P_{DMAX}$, $T_A = +25^{\circ}C$	0.15	0.25	-	
RMS Noise, % of V_{OUT}	eN	$T_A = +25^{\circ}C$, $10Hz < f < 10KHz$	-	0.003	-	% / V_O
Ripple Rejection	RR	$V_O = 10V$, $f = 120Hz$ without CADJ CADJ = 10 μF (Note4)	66	65 80	-	dB
Long-Term Stability	ST	$T_J = +125^{\circ}C$, 1000Hours	-	0.3	1	% / 1000Hrs

Note :

- Thermal resistance test board
Size: 76.2mm * 114.3mm * 1.6mm(1SOP)
JEDEC standard: JESD51-3, JESD51-7
- Assume no ambient airflow.
- Load and Line regulation are specified at constant junction temperature. Change in V_O due to heating effects must be taken into account separately. Pulse testing with low duty cycle is used.
- CADJ, when used, is connected between the adjustment pin and ground.

Typical Performance Characteristics

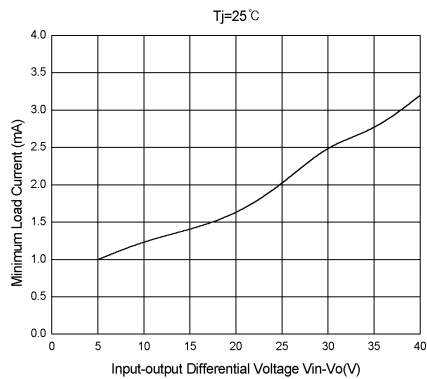

Figure 1. Minimum Load Current

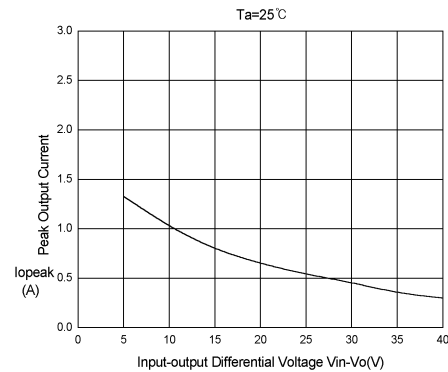

Figure 2. Peak Output Current vs. Input-Output Differential Voltage

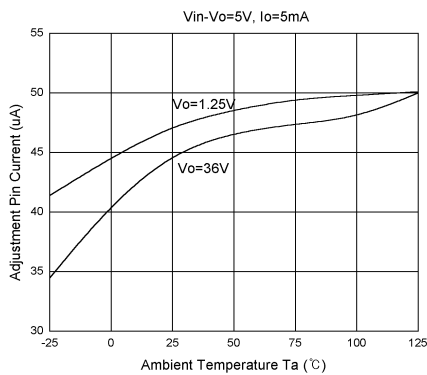

Figure 3. Adjustment Pin Current vs. Temperature

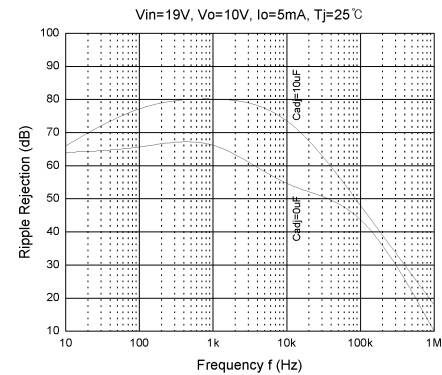

Figure 4. Ripple Rejection vs. Frequency

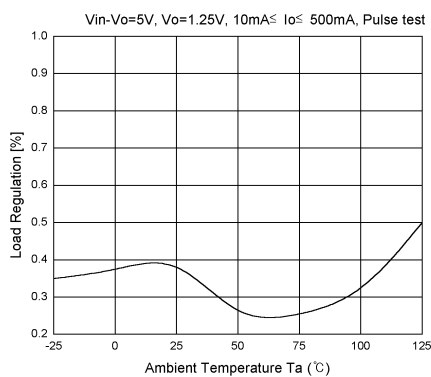

Figure 5. Load Regulation vs. Temperature

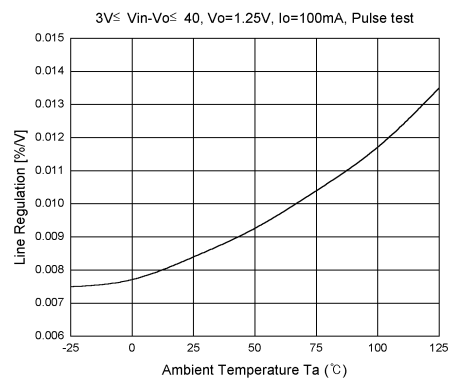

Figure 6. Line Regulation vs. Temperature

Typical Performance Characteristics (Continued)

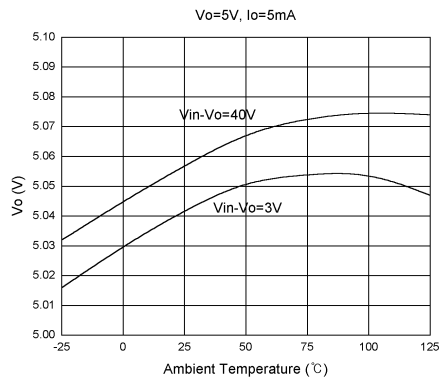

Figure 7. Output voltage vs. Temperature

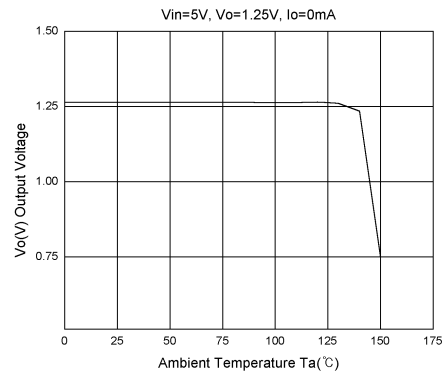

Figure 8. Thermal Shutdown

Typical Application

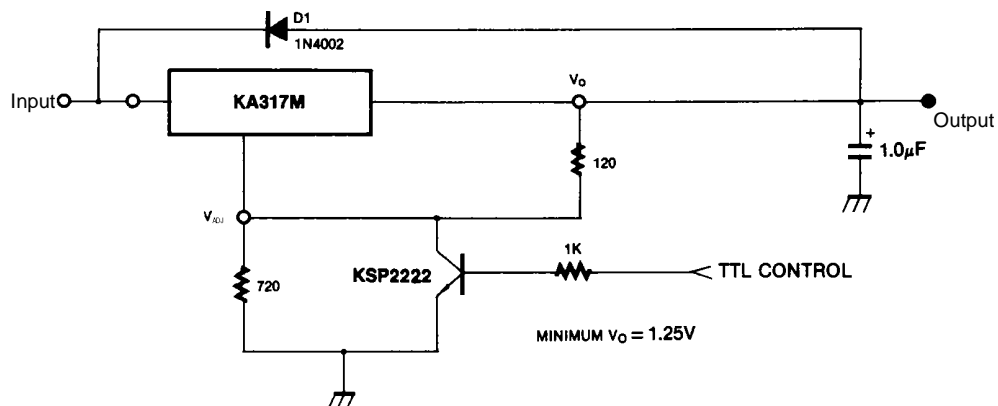

Figure 1. 15V Electronic Shutdown Regulator

D1 protects the device during an input short circuit.

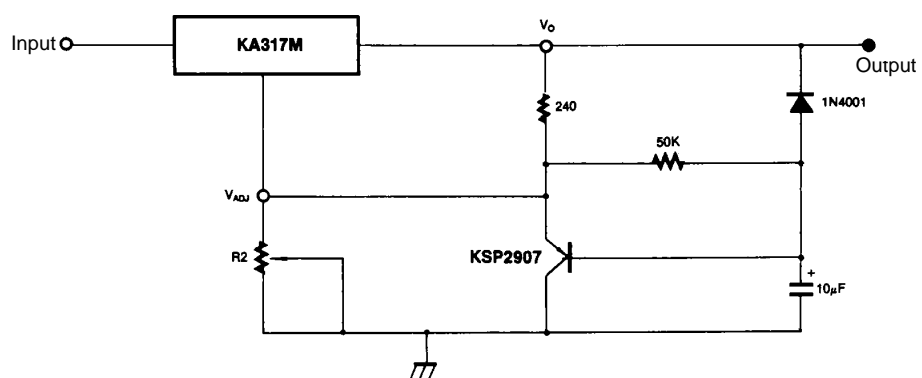
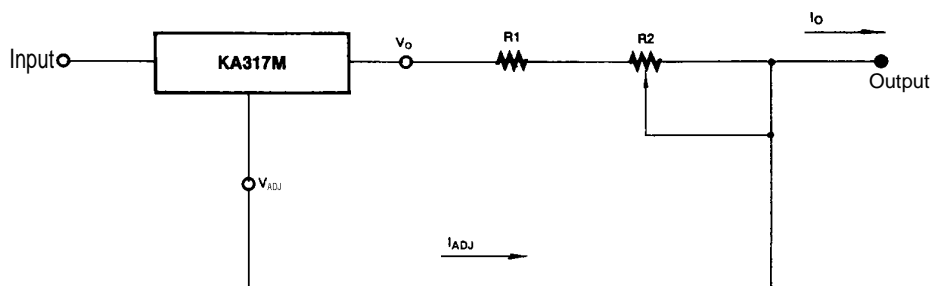

Figure 2. Slow Turn-On Regulator



$$I_{OMAX} = \left(\frac{V_{REF}}{R1} \right) + I_{ADJ} \approx \frac{1.25V}{R1}$$

$$I_{OMIN} = \left(\frac{V_{REF}}{R1 + R2} \right) + I_{ADJ} \approx \frac{1.25V}{R1 + R2}$$

$$5mA < I_O < 500mA$$

Figure 3. Current Regulator

Mechanical Dimensions

Package

Dimensions in millimeters

TO-220

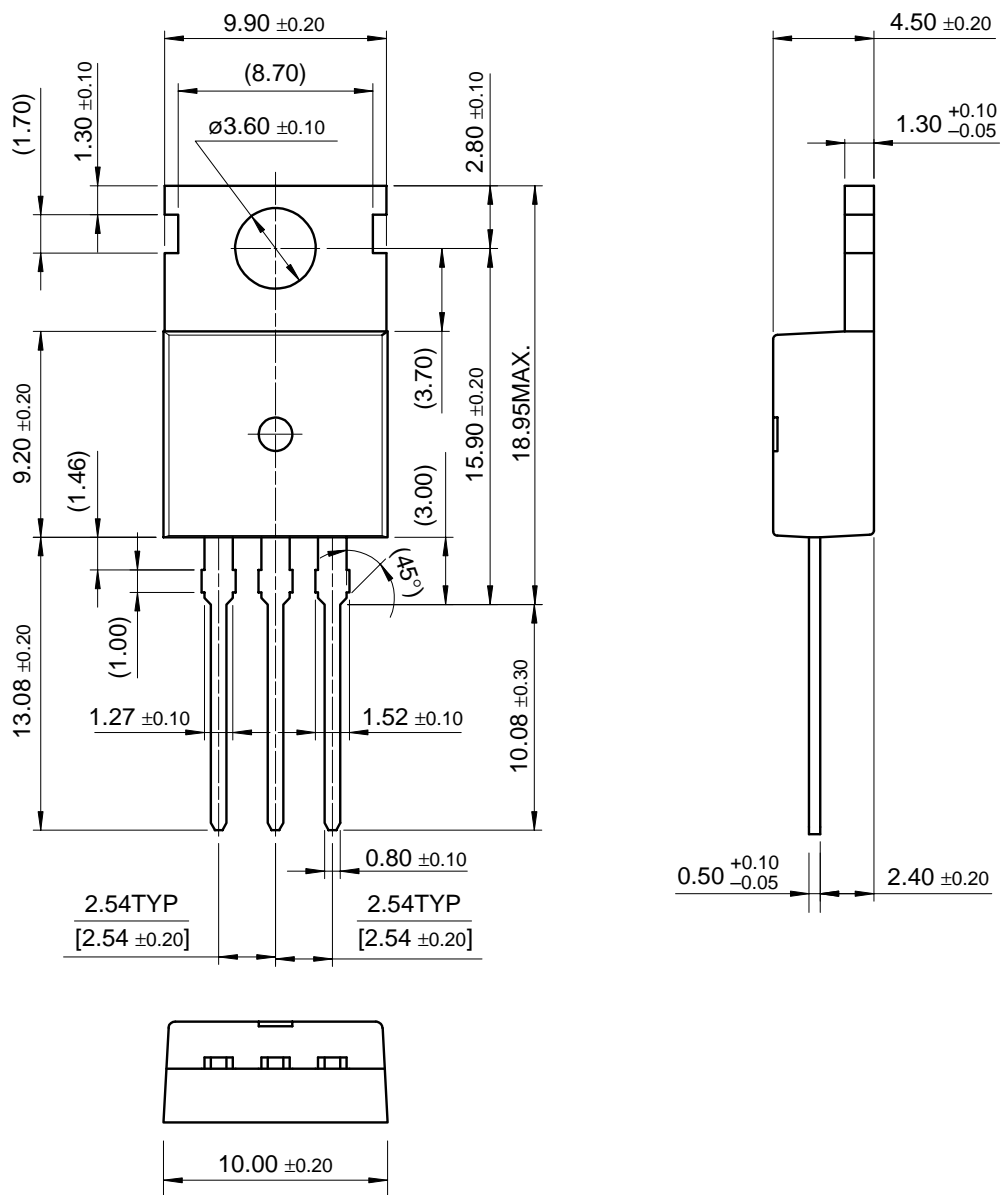

Mechanical Dimensions (Continued)

Package

Dimensions in millimeters

D-PAK

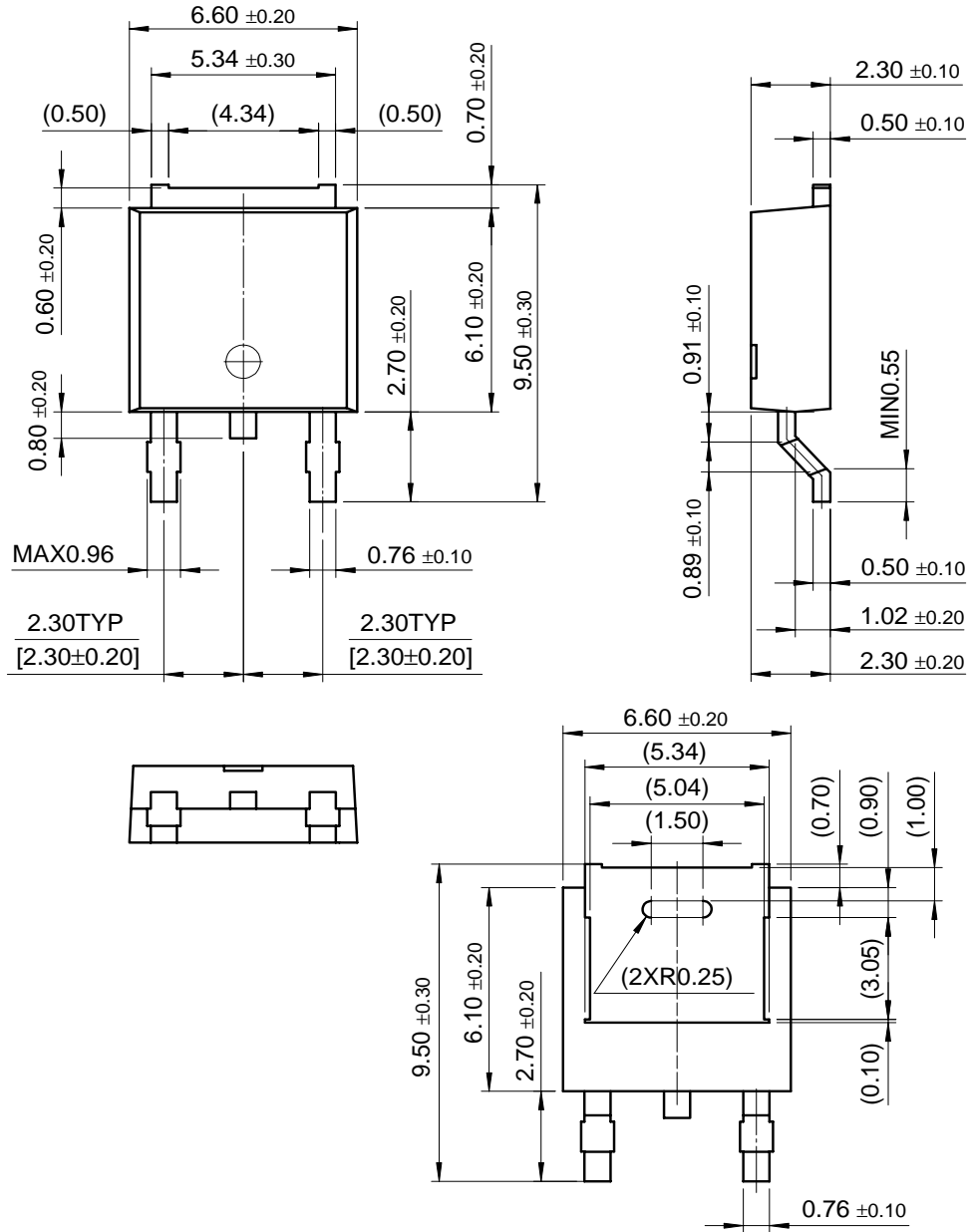

Ordering Information

Product Number	Package	Operating Temperature
KA317M	TO-220	0 ~ 125 °C
KA317MR	D-PAK	

DISCLAIMER

FAIRCHILD SEMICONDUCTOR RESERVES THE RIGHT TO MAKE CHANGES WITHOUT FURTHER NOTICE TO ANY PRODUCTS HEREIN TO IMPROVE RELIABILITY, FUNCTION OR DESIGN. FAIRCHILD DOES NOT ASSUME ANY LIABILITY ARISING OUT OF THE APPLICATION OR USE OF ANY PRODUCT OR CIRCUIT DESCRIBED HEREIN; NEITHER DOES IT CONVEY ANY LICENSE UNDER ITS PATENT RIGHTS, NOR THE RIGHTS OF OTHERS.

LIFE SUPPORT POLICY

FAIRCHILD'S PRODUCTS ARE NOT AUTHORIZED FOR USE AS CRITICAL COMPONENTS IN LIFE SUPPORT DEVICES OR SYSTEMS WITHOUT THE EXPRESS WRITTEN APPROVAL OF THE PRESIDENT OF FAIRCHILD SEMICONDUCTOR CORPORATION. As used herein:

1. Life support devices or systems are devices or systems which, (a) are intended for surgical implant into the body, or (b) support or sustain life, and (c) whose failure to perform when properly used in accordance with instructions for use provided in the labeling, can be reasonably expected to result in a significant injury of the user.
2. A critical component in any component of a life support device or system whose failure to perform can be reasonably expected to cause the failure of the life support device or system, or to affect its safety or effectiveness.