

## LM199/LM299/LM399/LM3999 Precision Reference

### General Description

The LM199 series are precision, temperature-stabilized monolithic zeners offering temperature coefficients a factor of ten better than high quality reference zeners. Constructed on a single monolithic chip is a temperature stabilizer circuit and an active reference zener. The active circuitry reduces the dynamic impedance of the zener to about  $0.5\Omega$  and allows the zener to operate over 0.5 mA to 10 mA current range with essentially no change in voltage or temperature coefficient. Further, a new subsurface zener structure gives low noise and excellent long term stability compared to ordinary monolithic zeners. The package is supplied with a thermal shield to minimize heater power and improve temperature regulation.

The LM199 series references are exceptionally easy to use and free of the problems that are often experienced with ordinary zeners. There is virtually no hysteresis in reference voltage with temperature cycling. Also, the LM199 is free of voltage shifts due to stress on the leads. Finally, since the unit is temperature stabilized, warm up time is fast.

The LM199 can be used in almost any application in place of ordinary zeners with improved performance. Some ideal applications are analog to digital converters, calibration standards, precision voltage or current sources or precision power supplies. Further in many cases the LM199 can replace references in existing equipment with a minimum of wiring changes.

The LM199 series devices are packaged in a standard hermetic TO-46 package inside a thermal shield. The LM199 is rated for operation from  $-55^{\circ}\text{C}$  to  $+125^{\circ}\text{C}$  while the LM299 is rated for operation from  $-25^{\circ}\text{C}$  to  $+85^{\circ}\text{C}$  and the LM399 is rated from  $0^{\circ}\text{C}$  to  $+70^{\circ}\text{C}$ .

The LM3999 is packaged in a standard TO-92 package and is rated from  $0^{\circ}\text{C}$  to  $+70^{\circ}\text{C}$ .

### Features

- Guaranteed  $0.0001\%/^{\circ}\text{C}$  temperature coefficient
- Low dynamic impedance —  $0.5\Omega$
- Initial tolerance on breakdown voltage — 2%
- Sharp breakdown at 400  $\mu\text{A}$
- Wide operating current — 500  $\mu\text{A}$  to 10 mA
- Wide supply range for temperature stabilizer
- Guaranteed low noise
- Low power for stabilization — 300 mW at  $25^{\circ}\text{C}$
- Long term stability — 20 ppm
- Proven reliability, low-stress packaging in TO-46 integrated-circuit hermetic package, for low hysteresis after thermal cycling. 33 million hours MTBF at  $T_A = +25^{\circ}\text{C}$  ( $T_J = +86^{\circ}\text{C}$ )
- Certified long term stability available
- MIL-STD-883 compliant

### Connection Diagrams

Metal Can Package (TO-46)

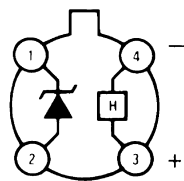

DS005717-14

**Top View**  
LM199/LM299/LM399 (See Table on fourth page)  
NS Package Number H04D

Plastic Package TO-92

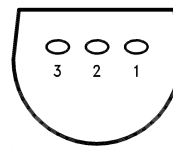

DS005717-10

**Bottom View**  
LM3999 (See Table on fourth page)  
NS Package Number Z03A

## Functional Block Diagrams

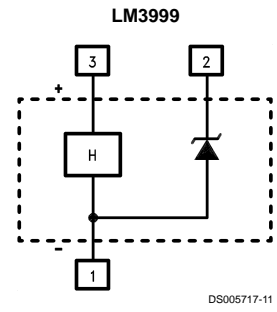
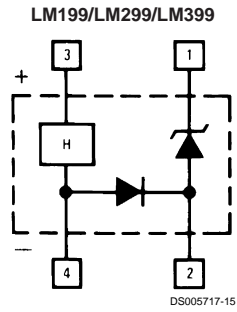

## Absolute Maximum Ratings (Note 1)

Specifications for Military/Aerospace products are not contained in this datasheet. Refer to the following Reliability Electrical Test Specifications documents: RETS199X for LM199, RETS199AX for LM199A.

Temperature Stabilizer Voltage	
LM199/LM299/LM399	40V
LM3999	36V
Reverse Breakdown Current	20 mA
Forward Current	
LM199/LM299/LM399	1 mA
LM3999	-0.1 mA

Reference to Substrate Voltage $V_{(RS)}$ (Note 2)	40V -0.1V
Operating Temperature Range	
LM199	-55°C to +125°C
LM299	-25°C to +85°C
LM399/LM3999	-0°C to +70°C
Storage Temperature Range	-55°C to +150°C
Soldering Information	
TO-92 package (10 sec.)	+260°C
TO-46 package (10 sec.)	+300°C

## Electrical Characteristics (Notes 3, 6)

Parameter	Conditions	LM199H/LM299H			LM399H			Units	
		Min	Typ	Max	Min	Typ	Max		
Reverse Breakdown Voltage	$0.5 \text{ mA} \leq I_R \leq 10 \text{ mA}$	6.8	6.95	7.1	6.6	6.95	7.3	V	
Reverse Breakdown Voltage Change with Current	$0.5 \text{ mA} \leq I_R \leq 10 \text{ mA}$		6	9		6	12	mV	
Reverse Dynamic Impedance	$I_R = 1 \text{ mA}$		0.5	1		0.5	1.5	$\Omega$	
Reverse Breakdown Temperature Coefficient	$-55^\circ\text{C} \leq T_A \leq +85^\circ\text{C}$	LM199	0.00003	0.0001				%/°C	
	$+85^\circ\text{C} \leq T_A \leq +125^\circ\text{C}$		0.00005	0.0015				%/°C	
	$-25^\circ\text{C} \leq T_A \leq +85^\circ\text{C}$		LM299	0.00003				0.0001	%/°C
	$0^\circ\text{C} \leq T_A \leq +70^\circ\text{C}$			LM3999					0.00003
RMS Noise	$10 \text{ Hz} \leq f \leq 10 \text{ kHz}$		7	20		7	50	$\mu\text{V}$	
Long Term Stability	Stabilized, $22^\circ\text{C} \leq T_A \leq 28^\circ\text{C}$ , 1000 Hours, $I_R = 1 \text{ mA} \pm 0.1\%$		20			20		ppm	
Temperature Stabilizer Supply Current	$T_A = 25^\circ\text{C}$ , Still Air, $V_S = 30\text{V}$		8.5	14		8.5	15	mA	
	$T_A = -55^\circ\text{C}$		22	28					
Temperature Stabilizer Supply Voltage		9		40	9		40	V	
Warm-Up Time to 0.05%	$V_S = 30\text{V}$ , $T_A = 25^\circ\text{C}$		3			3		sec.	
Initial Turn-on Current	$9 \leq V_S \leq 40$ , $T_A = +25^\circ\text{C}$ , (Note 4)		140	200		140	200	mA	

**Note 1:** "Absolute Maximum Ratings" indicate limits beyond which damage to the device may occur. Operating Ratings indicate conditions for which the device is functional, but do not guarantee specific performance limits.

## Electrical Characteristics (Note 3)

Parameter	Conditions	LM3999Z			Units
		Min	Typ	Max	
Reverse Breakdown Voltage	$0.6 \text{ mA} \leq I_R \leq 10 \text{ mA}$	6.6	6.95	7.3	V
Reverse Breakdown Voltage Change with Current	$0.6 \text{ mA} \leq I_R \leq 10 \text{ mA}$		6	20	mV
Reverse Dynamic Impedance	$I_R = 1 \text{ mA}$		0.6	2.2	$\Omega$
Reverse Breakdown Temperature Coefficient	$0^\circ\text{C} \leq T_A \leq 70^\circ\text{C}$		0.0002	0.0005	%/°C
RMS Noise	$10 \text{ Hz} \leq f \leq 10 \text{ kHz}$		7		$\mu\text{V}$
Long Term Stability	Stabilized, $22^\circ\text{C} \leq T_A \leq 28^\circ\text{C}$ , 1000 Hours, $I_R = 1 \text{ mA} \pm 0.1\%$		20		ppm
Temperature Stabilizer	$T_A = 25^\circ\text{C}$ , Still Air, $V_S = 30\text{V}$		12	18	mA
Temperature Stabilizer Supply Voltage				36	V
Warm-Up Time to 0.05%	$V_S = 30\text{V}$ , $T_A = 25^\circ\text{C}$		5		sec.

## Electrical Characteristics (Note 3) (Continued)

Parameter	Conditions	LM3999Z			Units
		Min	Typ	Max	
Initial Turn-On Current	$9 \leq V_S \leq 40, T_A = 25^\circ\text{C}$		140	200	mA

## Electrical Characteristics (Notes 3, 6)

Parameter	Conditions	LM199AH, LM299AH			LM399AH			Units			
		Min	Typ	Max	Min	Typ	Max				
Reverse Breakdown Voltage	$0.5 \text{ mA} \leq I_R \leq 10 \text{ mA}$	6.8	6.95	7.1	6.6	6.95	7.3	V			
Reverse Breakdown Voltage Change with Current	$0.5 \text{ mA} \leq I_R \leq 10 \text{ mA}$		6	9		6	12	mV			
Reverse Dynamic Impedance	$I_R = 1 \text{ mA}$		0.5	1		0.5	1.5	$\Omega$			
Reverse Breakdown Temperature Coefficient	$-55^\circ\text{C} \leq T_A \leq +85^\circ\text{C}$	LM199A	0.00002	0.00005				%/°C			
	$+85^\circ\text{C} \leq T_A \leq +125^\circ\text{C}$		0.0005	0.0010				%/°C			
	$-25^\circ\text{C} \leq T_A \leq +85^\circ\text{C}$	LM299A	0.00002	0.00005							%/°C
	$0^\circ\text{C} \leq T_A \leq +70^\circ\text{C}$										LM399A
RMS Noise	$10 \text{ Hz} \leq f \leq 10 \text{ kHz}$		7	20		7	50	$\mu\text{V}$			
Long Term Stability	Stabilized, $22^\circ\text{C} \leq T_A \leq 28^\circ\text{C}$ , 1000 Hours, $I_R = 1 \text{ mA} \pm 0.1\%$		20			20		ppm			
Temperature Stabilizer Supply Current	$T_A = 25^\circ\text{C}$ , Still Air, $V_S = 30\text{V}$ $T_A = -55^\circ\text{C}$		8.5	14		8.5	15	mA			
Temperature Stabilizer Supply Voltage		9		40	9		40	V			
Warm-Up Time to 0.05%	$V_S = 30\text{V}, T_A = 25^\circ\text{C}$		3			3		sec.			
Initial Turn-on Current	$9 \leq V_S \leq 40, T_A = +25^\circ\text{C}$ , (Note 4)		140	200		140	200	mA			

**Note 2:** The substrate is electrically connected to the negative terminal of the temperature stabilizer. The voltage that can be applied to either terminal of the reference is 40V more positive or 0.1V more negative than the substrate.

**Note 3:** These specifications apply for 30V applied to the temperature stabilizer and  $-55^\circ\text{C} \leq T_A \leq +125^\circ\text{C}$  for the LM199;  $-25^\circ\text{C} \leq T_A \leq +85^\circ\text{C}$  for the LM299 and  $0^\circ\text{C} \leq T_A \leq +70^\circ\text{C}$  for the LM399 and LM3999.

**Note 4:** This initial current can be reduced by adding an appropriate resistor and capacitor to the heater circuit. See the performance characteristic graphs to determine values.

**Note 5:** Do not wash the LM199 with its polysulfone thermal shield in TCE.

**Note 6:** A military RETS electrical test specification is available for the LM199H/883, LM199AH/883, and LM199AH-20/883 on request.

## Ordering Information

Initial Tolerance	0°C to +70°C	-25°C to +85°C	-55°C to +125°C	NS Package
2%		LM299AH	LM199AH, LM199AH/883	H04D
5%	LM399H LM399AH	LM299H		H04D
5%	LM3999Z			Z03A

## Certified Long Term Drift

The National Semiconductor LM199AH-20, LM299AH-20, and LM399AH-50 are ultra-stable Zener references specially selected from the production runs of LM199AH, LM299AH, LM399AH and tested to confirm a long-term stability of 20, 20, or 50 ppm per 1000 hours, respectively. The devices are measured every 168 hours and the voltage of each device is logged and compared in such a way as to show the deviation from its initial value. Each measurement is taken with a probable-worst-case deviation of  $\pm 2$  ppm, compared to the Reference Voltage, which is derived from several groups of NBS-traceable references such as LM199AH-20's, 1N827's,

and saturated standard cells, so that the deviation of any one group will not cause false indications. Indeed, this comparison process has recently been automated using a specially prepared computer program which is custom-designed to reject noisy data (and require a repeat reading) and to record the average of the best 5 of 7 readings, just as a sagacious standards engineer will reject unbelievable readings.

The typical characteristic for the LM199AH-20 is shown below. This computerized print-out form of each reference's stability is shipped with the unit.

## Typical Characteristics

National Semiconductor  
Certified Long Term Drift

Hrs	Drift
168	-20
336	-24
504	-36
672	-34
840	-40
1008	-36

### Testing Conditions

Heater Voltage: 30V  
Zener Current: 1 mA  
Ambient Temp.: 25°C

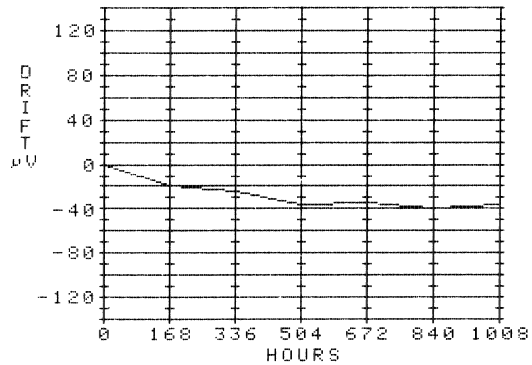

## Typical Performance Characteristics

### Reverse Characteristics

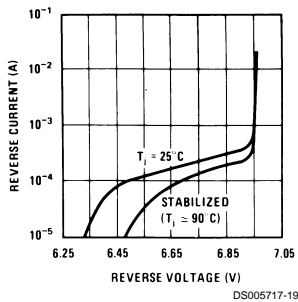

### Reverse Voltage Change

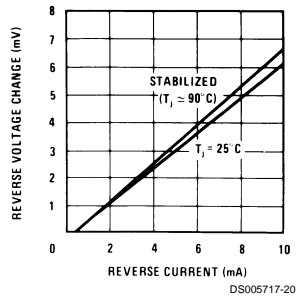

### Dynamic Impedance

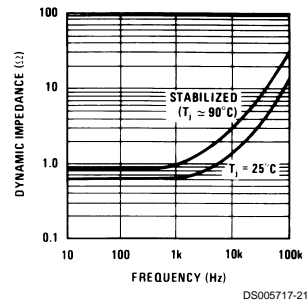

### Zener Noise Voltage

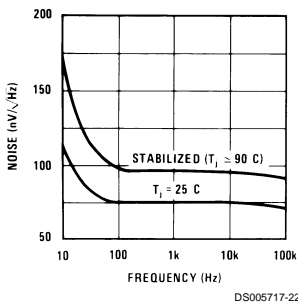

### Stabilization Time

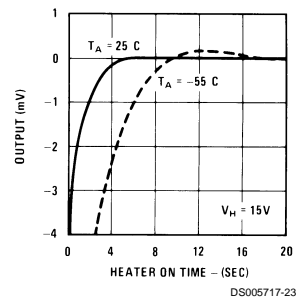

### Heater Current

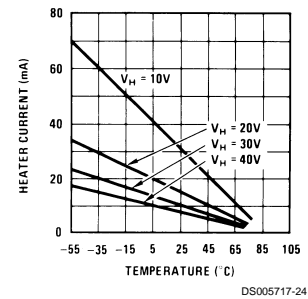

## Typical Performance Characteristics (Continued)

Initial Heater Current

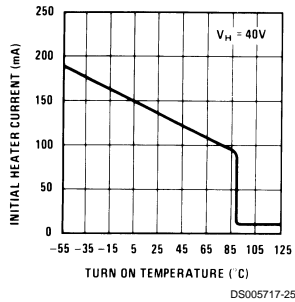

Heater Current (To Limit This Surge, See Next Graph)

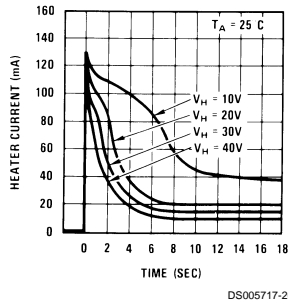

Heater Surge Limit Resistor vs Minimum Supply Voltage at Various Minimum Temperatures

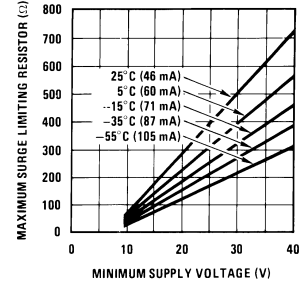

\*Heater must be bypassed with a 2 μF or larger tantalum capacitor if resistors are used.

Low Frequency Noise Voltage

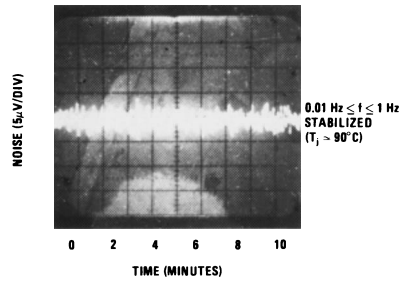

Response Time

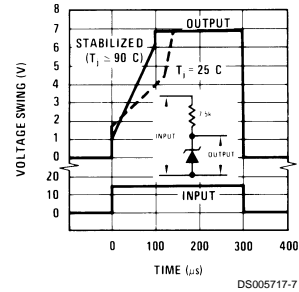

## Typical Applications

Single Supply Operation

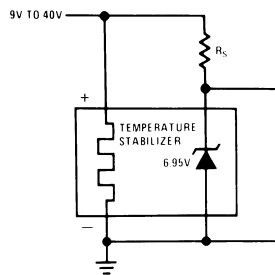

Split Supply Operation

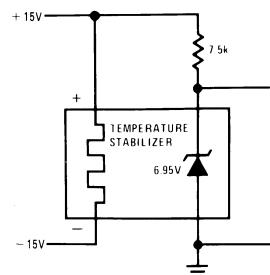

## Typical Applications (Continued)

**Negative Heater Supply with Positive Reference**

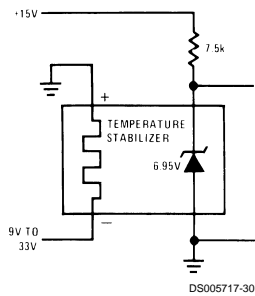

**Buffered Reference With Single Supply**

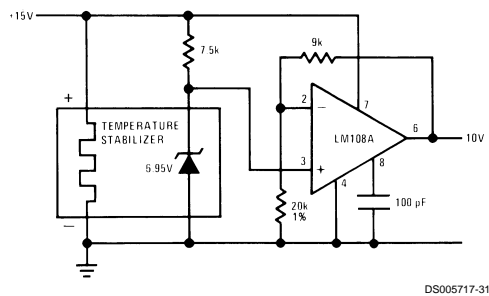

**Positive Current Source**

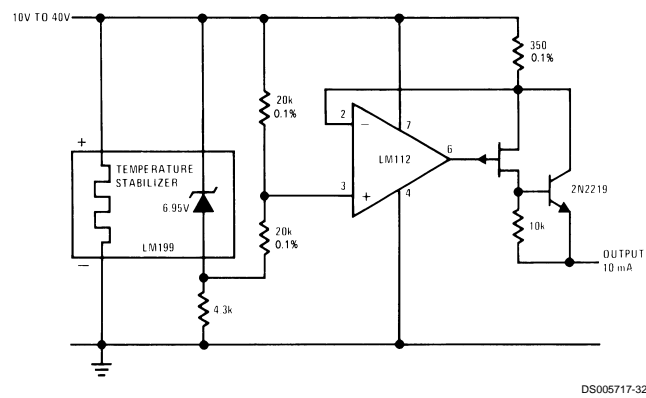

**Standard Cell Replacement**

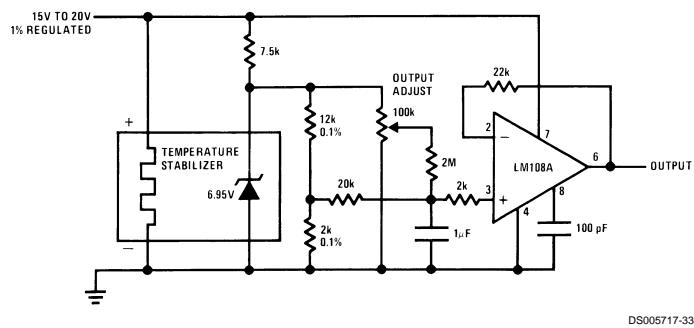

## Typical Applications (Continued)

### Negative Current Source

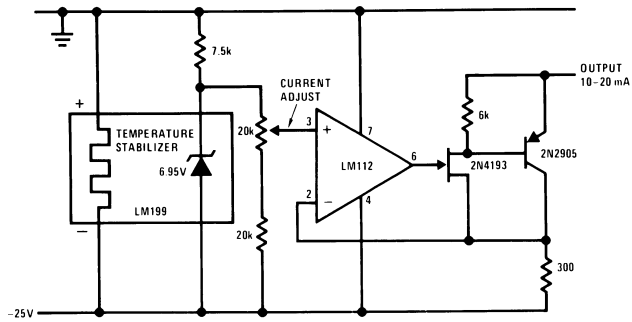

DS005717-34

### Square Wave Voltage Reference

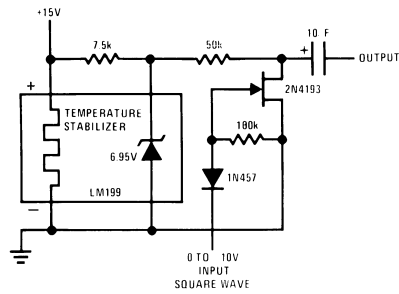

DS005717-35

### Portable Calibrator\*

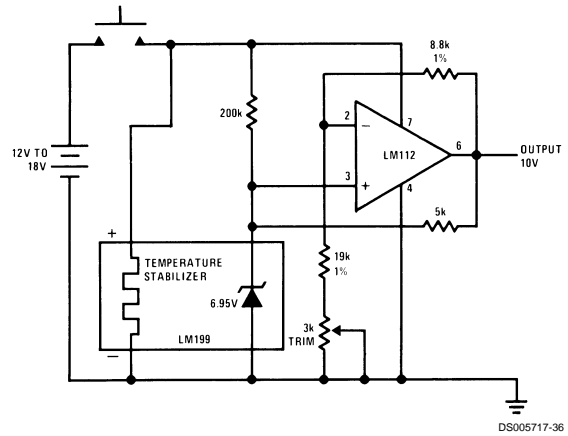

DS005717-36

\*Warm-up time 10 seconds; intermittent operation does not degrade long term stability.

### 14V Reference

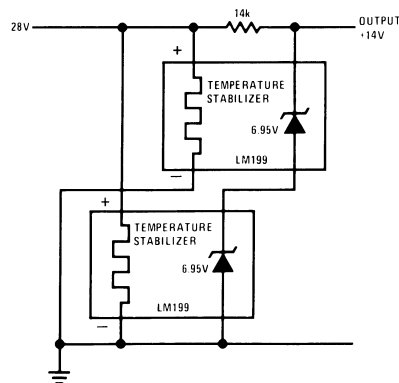

DS005717-37

### Precision Clamp\*

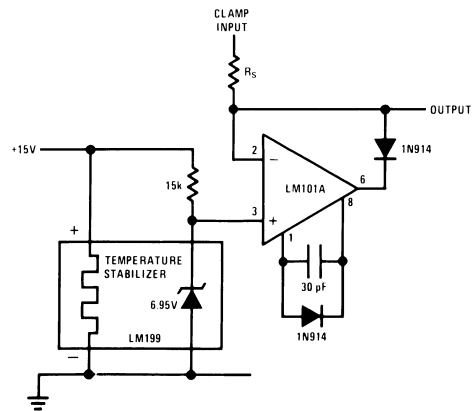

DS005717-38

\*Clamp will sink 5 mA when input goes more positive than reference



## Typical Applications (Continued)

### 0V to 20V Power Reference

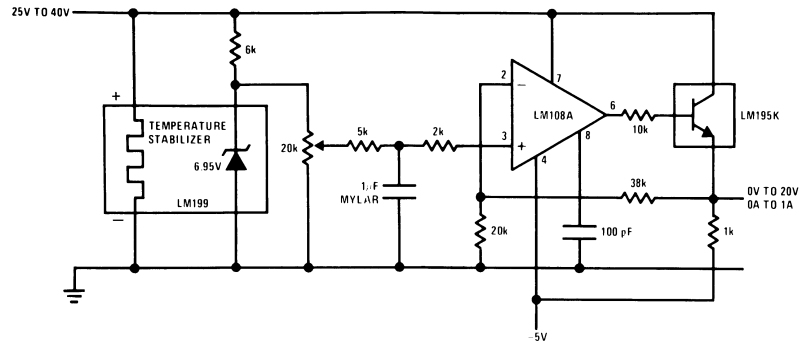

DS005717-39

### Bipolar Output Reference

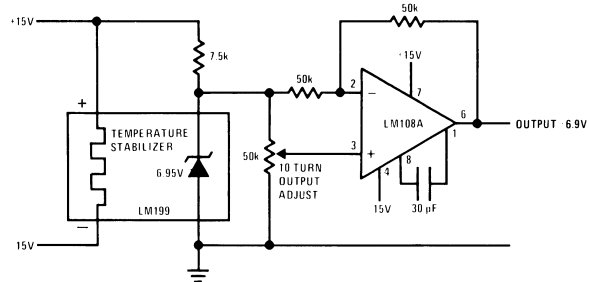

DS005717-40

### Voltage Reference

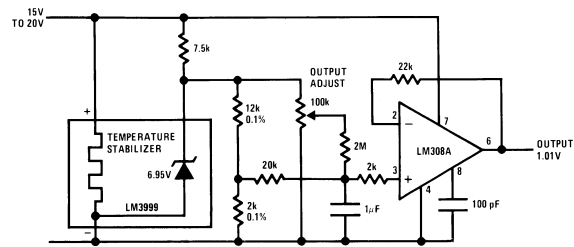

DS005717-9

## Schematic Diagrams

### Temperature Stabilizer

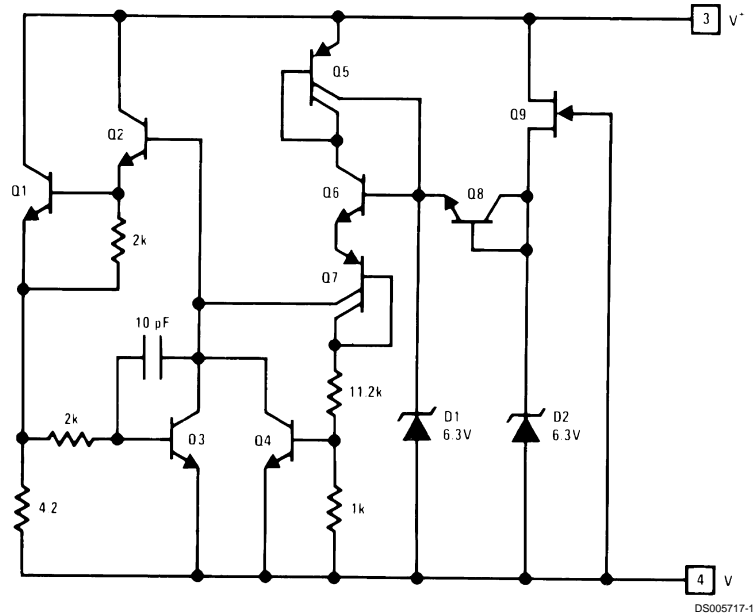

### Reference

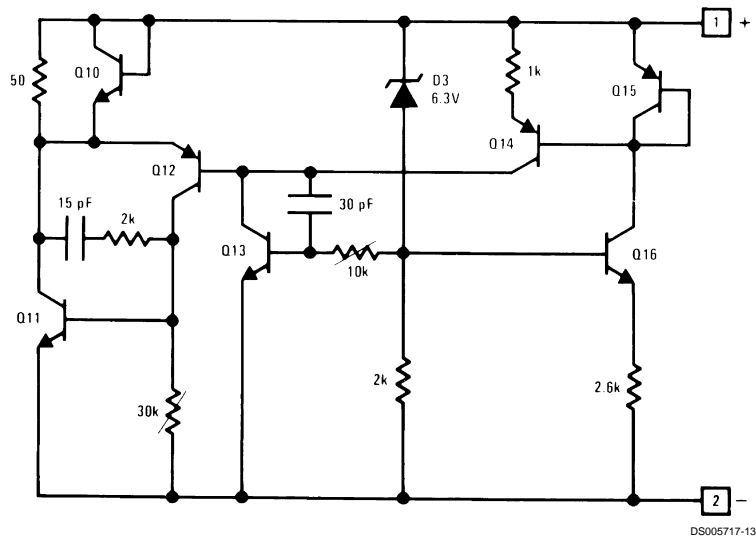

**Physical Dimensions** inches (millimeters) unless otherwise noted

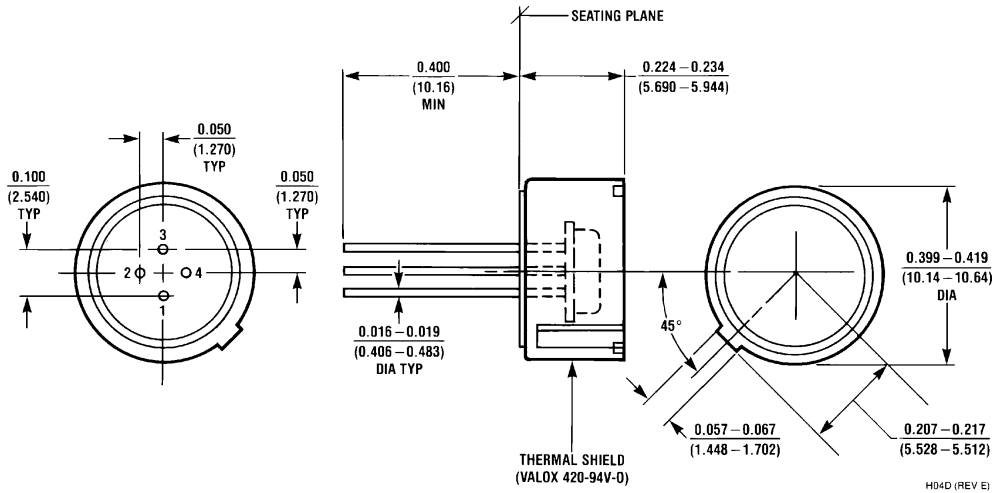

Order Number LM299H, LM399H, LM199AH, LM199AH/883  
LM299AH or LM399AH  
NS Package H04D

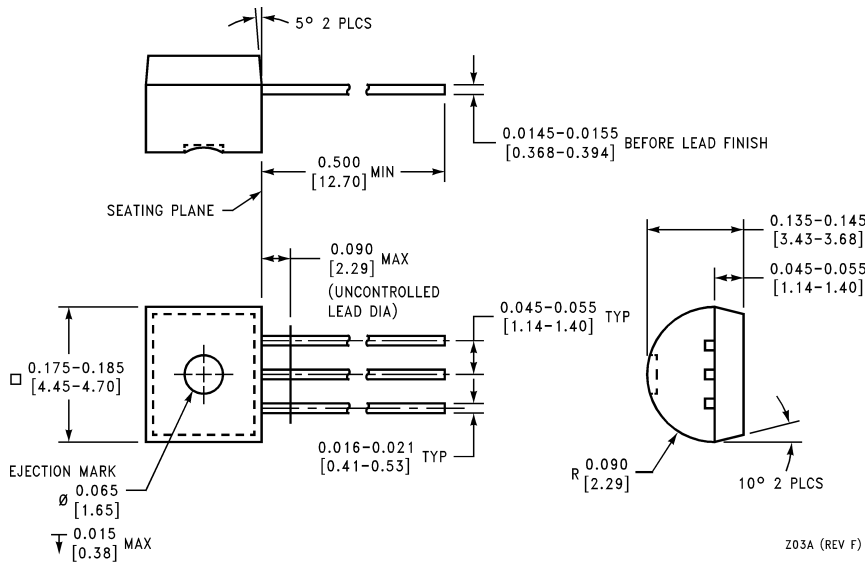

Plastic Package  
Order Number LM3999Z  
NS Package Z03A

## Notes

### LIFE SUPPORT POLICY

NATIONAL'S PRODUCTS ARE NOT AUTHORIZED FOR USE AS CRITICAL COMPONENTS IN LIFE SUPPORT DEVICES OR SYSTEMS WITHOUT THE EXPRESS WRITTEN APPROVAL OF THE PRESIDENT AND GENERAL COUNSEL OF NATIONAL SEMICONDUCTOR CORPORATION. As used herein:

1. Life support devices or systems are devices or systems which, (a) are intended for surgical implant into the body, or (b) support or sustain life, and whose failure to perform when properly used in accordance with instructions for use provided in the labeling, can be reasonably expected to result in a significant injury to the user.
2. A critical component is any component of a life support device or system whose failure to perform can be reasonably expected to cause the failure of the life support device or system, or to affect its safety or effectiveness.



**National Semiconductor Corporation**  
Americas  
Tel: 1-800-272-9959  
Fax: 1-800-737-7018  
Email: support@nsc.com

[www.national.com](http://www.national.com)

**National Semiconductor Europe**  
Fax: +49 (0) 1 80-530 85 86  
Email: europe.support@nsc.com  
Deutsch Tel: +49 (0) 1 80-530 85 85  
English Tel: +49 (0) 1 80-532 78 32  
Français Tel: +49 (0) 1 80-532 93 58  
Italiano Tel: +49 (0) 1 80-534 16 80

**National Semiconductor Asia Pacific Customer Response Group**  
Tel: 65-2544466  
Fax: 65-2504466  
Email: sea.support@nsc.com

**National Semiconductor Japan Ltd.**  
Tel: 81-3-5639-7560  
Fax: 81-3-5639-7507

National does not assume any responsibility for use of any circuitry described, no circuit patent licenses are implied and National reserves the right at any time without notice to change said circuitry and specifications.