

LMV7251/LMV7255

1.8V Low Voltage Comparator with Rail-to-Rail Input

General Description

The LMV7251/LMV7255 are rail-to-rail input low voltage comparators, which can operate at supply voltage range of 1.8V to 5.0V. The LMV7251/LMV7255 are available in space saving SC-70 or SOT23-5 packages. These comparators are ideal for low voltage and space critical designs.

The LMV7251 features a push-pull output stage. This feature allows operation with minimum power consumption when driving a load.

The LMV7255 features an open drain output. This allows the connection of an external resistor at the output. The output of the comparator can be used as a level shifter.

The IC's are built with National Semiconductor's advance Submicron Silicon-Gate BiCMOS process. The LMV7251/LMV7255 have bipolar inputs for improved noise performance and CMOS outputs for better rail-to-rail output performance.

Features

($V_S = 1.8V$, $T_A = 25^\circ C$, Typical values unless specified).

- Single or Dual Supplies
- Low supply voltage 1.8V to 5.0V
- Ultra low supply current 11 μA
- Low input bias current 14nA
- Low input offset current 200pA
- Low input offset voltage $\pm 0.3mV$
- Response time 670ns (20mV overdrive)
- Input common mode voltage 0.1V beyond rails

Applications

- Mobile communications
- Laptops and PDA's
- Battery powered electronics
- General purpose low voltage applications

Typical Circuit

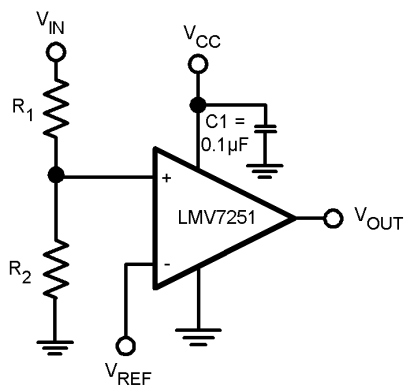

DS200057-2

FIGURE 1. Threshold Detector

Connection Diagram

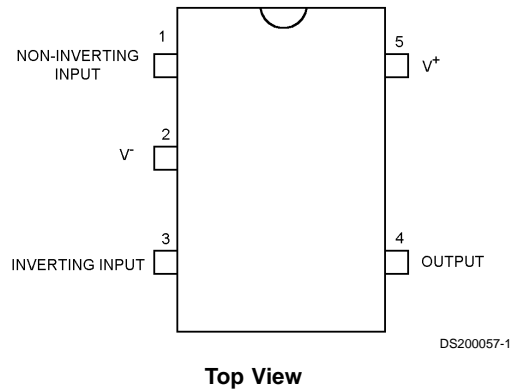

DS200057-1

Absolute Maximum Ratings (Note 1)

If Military/Aerospace specified devices are required, please contact the National Semiconductor Sales Office/ Distributors for availability and specifications.

ESD Tolerance	1KV (Note 2) 200V (Note 6)
V _{IN} Differential	+/-Supply Voltage
Supply Voltage (V ⁺ - V ⁻)	5.5V
Voltage at Input/Output pins	V ⁺ +0.1V, V ⁻ -0.1V
Soldering Information	
Infrared or Convection (20 sec.)	235°C

Wave Soldering (10 sec.)	260°C
Storage Temperature Range	-65°C to +150°C
Junction Temperature (Note 4)	+150°C

Operating Ratings (Note 1)

Supply Voltage V ⁺	1.8V to 5.0V
Junction Temperature Range (Note 3)	-40°C to +85°C
Package Thermal Resistance (Note 3)	
SOT23-5	325°C/W
SC-70	265°C/W

1.8V Electrical Characteristics

Unless otherwise specified, all limits guaranteed for T_J = 25°C, V⁺ = 1.8V, V⁻ = 0V. **Boldface** limits apply at the temperature extremes.

Symbol	Parameter	Condition	Typ (Note 4)	Limits (Note 5)	Units
V _{OS}	Input Offset Voltage		0.3	6 8	mV max
TC V _{OS}	Input Offset Average Drift	V _{CM} = 0.9V (Note 7)	10		uV/C
I _B	Input Bias Current		14		nA
I _{OS}	Input Offset Current		200		pA
I _S	Supply Current		11	15 17	μA max
I _{SC}	Output Short Circuit Current	Sourcing, V _O = 0.9V (LMV7251 only)	8	4	mA min
		Sinking, V _O = 0.9V	11.6	5	
I _{LEAKAGE}	Output Leakage Current	V _O = 1.8V (LMV7255 only)	300		pA
V _{OH}	Output Voltage High	I _O = 1.5mA (LMV7251 only)	1.72	1.675	V min
V _{OL}	Output Voltage Low	I _O = -1.5mA	65	125	mV max
V _{CM}	Input Common Voltage Range	CMRR > 45 dB		1.9	V max
				-0.1	V min
CMRR	Common Mode Rejection Ratio	0 < V _{CM} < 1.8V	72	47	dB min
PSRR	Power Supply Rejection Ratio	V ⁺ = 1.8V to 5V	79	55	dB min

1.8V AC Electrical Characteristics

Unless otherwise specified, all limits guaranteed for T_J = 25°C, V⁺ = 1.8V, V⁻ = 0V, V_{CM} = 0.5V, V_O = V⁺/2. **Boldface** limits apply at the temperature extremes.

Symbol	Parameter	Condition	Typ (Note 5)	Limits (Note 6)	Units
t _{PHL}	Propagation Delay (High to Low)	Input Overdrive = 20mV Load = 50pF//5kΩ	720		ns
		Input Overdrive = 50mV Load = 50pF//5kΩ	380		ns

1.8V AC Electrical Characteristics (Continued)

Unless otherwise specified, all limits guaranteed for $T_J = 25^\circ\text{C}$, $V^+ = 1.8\text{V}$, $V^- = 0\text{V}$, $V_{\text{CM}} = 0.5\text{V}$, $V_O = V^+/2$. **Boldface** limits apply at the temperature extremes.

Symbol	Parameter	Condition	Typ (Note 5)	Limits (Note 6)	Units
t_{PLH}	Propagation Delay (Low to High)	Input Overdrive = 20mV Load = 50pF//5k Ω	670		ns
		Input Overdrive = 50mV Load = 50pF//5k Ω	400		ns

2.7V Electrical Characteristics

Unless otherwise specified, all limits guaranteed for $T_J = 25^\circ\text{C}$, $V^+ = 2.7\text{V}$, $V^- = 0\text{V}$. **Boldface** limits apply at the temperature extremes.

Symbol	Parameter	Conditions	Typ (Note 5)	Limits (Note 6)	Units
V_{OS}	Input Offset Voltage		0.03	6 8	mV max
TC V_{OS}	Input Offset Average Drift	$V_{\text{CM}} = 1.35\text{V}$ (Note 7)	10		$\mu\text{V}/\text{C}$
I_{B}	Input Bias Current		15		nA
I_{OS}	Input offset Current		210		pA
I_{S}	Supply Current		11	18 22	μA max
I_{SC}	Output Short Circuit Current	Sourcing, $V_O = 1.35\text{V}$ (LMV7251 only)	28	15	mA
		Sinking, $V_O = 1.35\text{V}$	28	15	
I_{LEAKAGE}	Output Leakage Current	$V_O = 2.7\text{V}$, (LMV7255 only)	320		pA
V_{OH}	Output Voltage High	$I_O = 2\text{mA}$ (LMV7251 only)	2.63	2.575	V min
V_{OL}	Output Voltage Low	$I_O = -2\text{mA}$	61	125	mV max
V_{CM}	Input Common Voltage Range	CMRR > 45dB		2.8	V max
				-0.1	V min
CMRR	Common Mode Rejection Ratio	$0 < V_{\text{CM}} < 2.7\text{V}$	75	46	dB min
PSRR	Power Supply Rejection Ratio	$V^+ = 1.8\text{V}$ to 5V	79	55	dB min

2.7V AC Electrical Characteristics

Unless otherwise specified, all limits guaranteed for $T_J = 25^\circ\text{C}$, $V^+ = 2.7\text{V}$, $V^- = 0\text{V}$. **Boldface** limits apply at the temperature extremes.

Symbol	Parameter	Condition	Typ (Note 5)	Limits (Note 6)	Units
t_{PHL}	Propagation Delay (High to Low)	Input Overdrive = 20mV Load = 50pF//5k Ω	830		ns
		Input Overdrive = 50mV Load = 50pF//5k Ω	430		ns
t_{PLH}	Propagation Delay (Low to High)	Input Overdrive = 20mV Load = 50pF//5k Ω	730		ns
		Input Overdrive = 50mV Load = 50pF//5k Ω	410		ns

5V Electrical Characteristics

Unless otherwise specified, all limits guaranteed for $T_J = 25^\circ\text{C}$, $V^+ = 5\text{V}$, $V^- = 0\text{V}$. **Boldface** limits apply at the temperature extremes.

Symbol	Parameter	Conditions	Typ (Note 5)	Limits (Note 6)	Units
V_{OS}	Input Offset Voltage		0.03	6 8	mV max
TC V_{OS}	Input Offset Average Drift	$V_{CM} = 2.5\text{V}$ (Note 7)	10		$\mu\text{V}/\text{C}$
I_B	Input Bias Current		16		nA
I_{OS}	Input Offset Current		220		pA
I_S	Supply Current		12	20 25	μA max
I_{SC}	Output Short Circuit Current	Sourcing, $V_O = 2.5\text{V}$ (LMV7251 only)	82	50	mA min
		Sinking, $V_O = 2.5\text{V}$	78	50	
$I_{LEAKAGE}$	Output Leakage Current	$V_O = 5\text{V}$, (LMV7255 only)	375		pA
V_{OH}	Output Voltage High	$I_O = 4\text{mA}$	4.9	4.82	V min
V_{OL}	Output Voltage Low	$I_O = -4\text{mA}$	90	180	mV max

Note 1: Absolute Maximum Ratings indicate limits beyond which damage to the device may occur. Operating Ratings indicate conditions for which the device is intended to be functional, but specific performance is not guaranteed. For guaranteed specifications and the test conditions, see the Electrical Characteristics.

Note 2: Human body model, $1.5\text{k}\Omega$ in series with 100pF .

Note 3: The maximum power dissipation is a function of $T_{J(max)}$, θ_{JA} , and T_A . The maximum allowable power dissipation at any ambient temperature is $P_D = (T_{J(max)} - T_A)/\theta_{JA}$. All numbers apply for packages soldered directly into a PC board.

Note 4: Typical values represent the most likely parametric norm.

Note 5: All limits are guaranteed by testing or statistical analysis.

Note 6: Machine Model, 0Ω in series with 200pF .

Note 7: Offset Voltage average drift determined by dividing the change in V_{OS} at temperature extremes into the total temperature change.

Typical Performance Characteristics ($T_A = 25^\circ\text{C}$, Unless otherwise specified).

Short Circuit Current vs. Supply Voltage

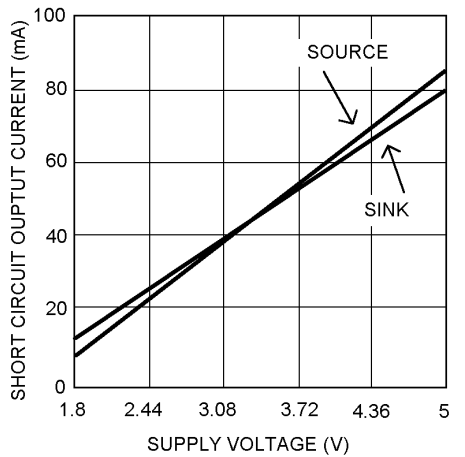

Supply Current vs. Supply Voltage

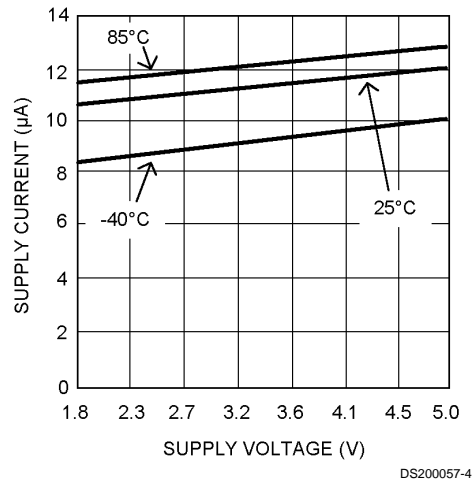

Output Voltage vs. Supply Voltage

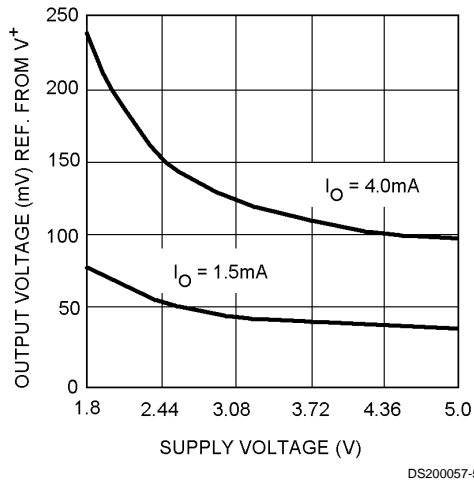

Output Voltage vs. Supply Voltage

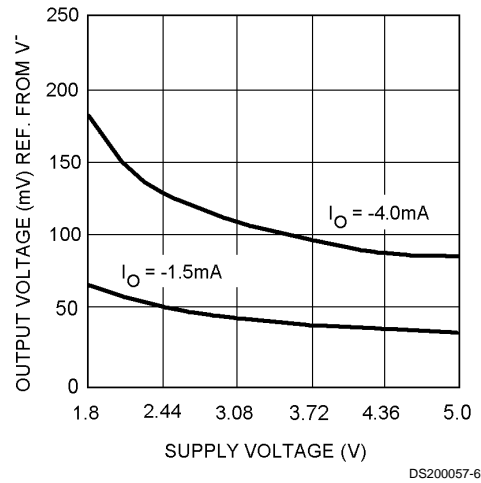

Output Voltage vs. Output Current @1.8V Supply Voltage

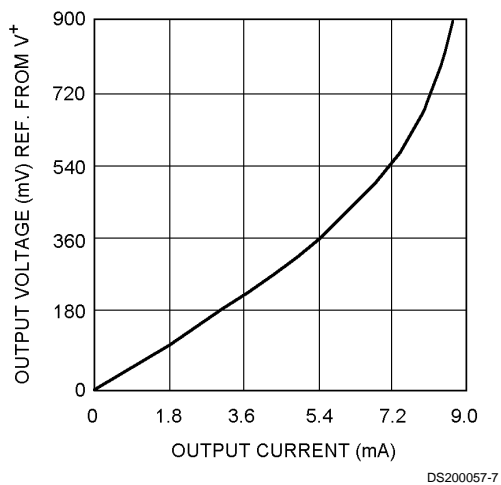

Output Voltage vs. Output Current @1.8V Supply Voltage

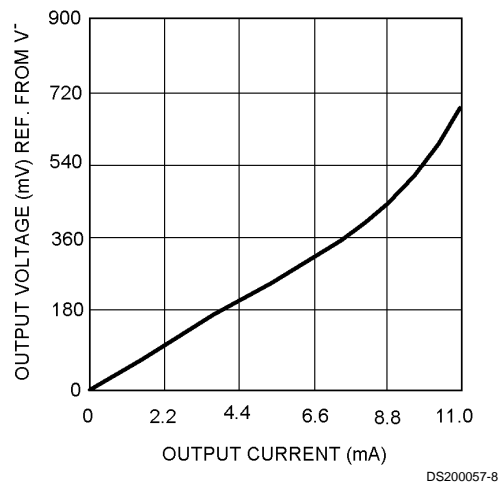

Typical Performance Characteristics ($T_A = 25^\circ\text{C}$, Unless otherwise specified). (Continued)

Output Voltage vs. Output Current @2.7V Supply Voltage

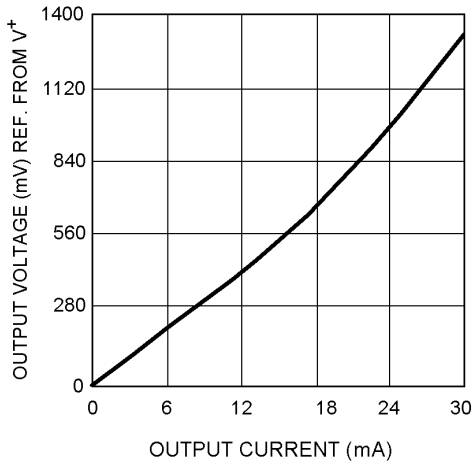

DS200057-9

Output Voltage vs. Output Current @2.7V Supply Voltage

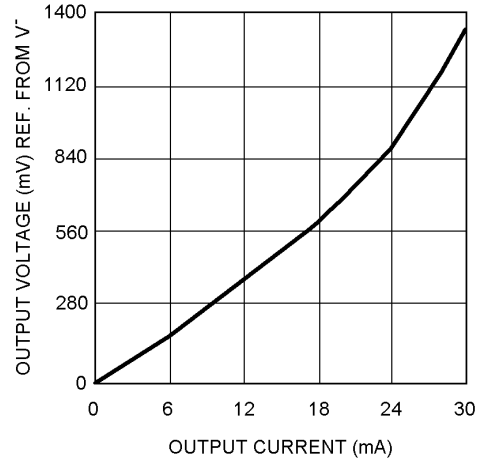

DS200057-10

Response Time for Various Input Overdrives - t_{PLH}

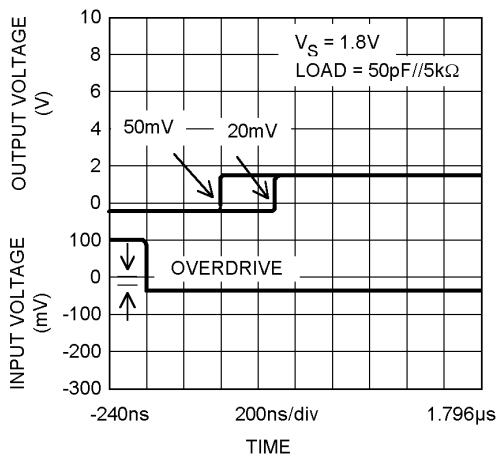

DS200057-11

Response Time for Various Input Overdrives - t_{PHL}

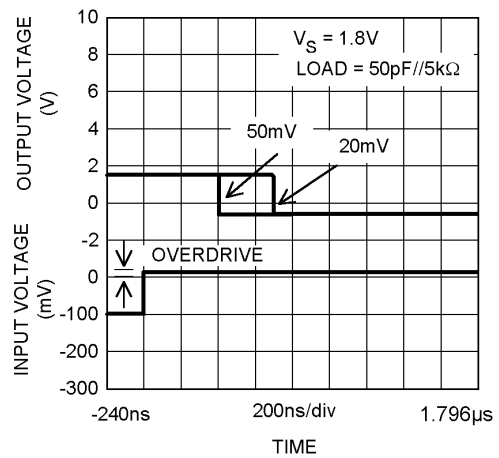

DS200057-12

Response Time for Various Input Overdrives - t_{PLH}

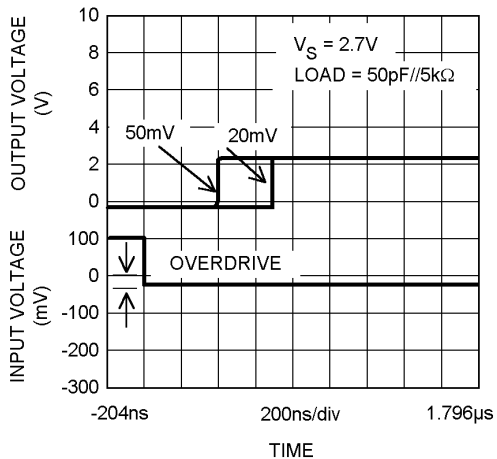

DS200057-13

Response Time for Various Input Overdrives - t_{PHL}

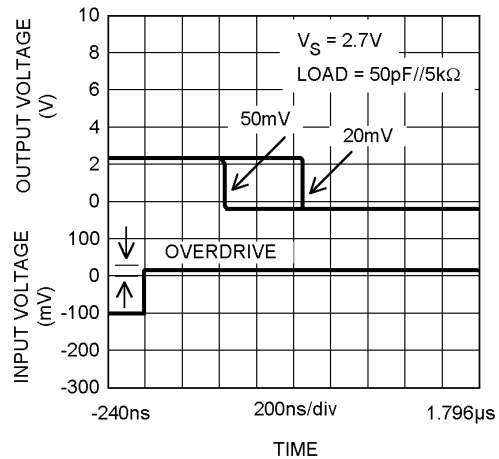

DS200057-14

Application Info

Basic Comparators

A comparator is quite often used to convert an analog signal to a digital signal. The comparator compares an input voltage (V_{IN}) at the non-inverting pin to the reference voltage (V_{REF}) at the inverting pin. If V_{IN} is less than V_{REF} the output (V_O) is low (V_{OL}). However, if V_{IN} is greater than V_{REF} , the output voltage (V_O) is high (V_{OH}).

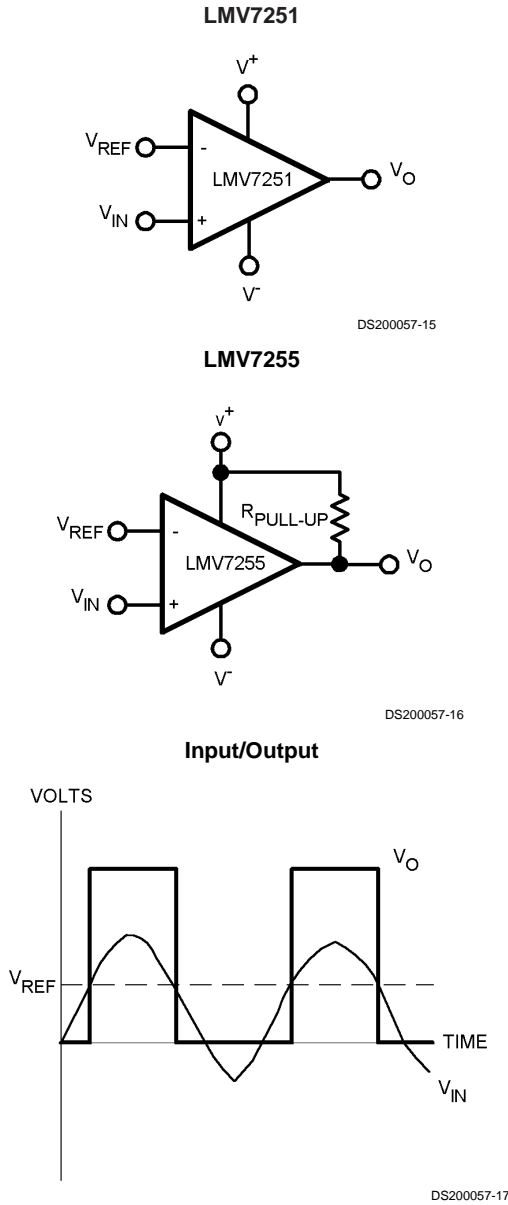

FIGURE 2. Basic Comparator

Hysteresis

The basic comparator configuration may oscillate or produce a noisy output if the applied differential input is near the comparator's input offset voltage. This tends to occur when the voltage on the input is equal or very close to the other input voltage. Adding hysteresis can prevent this problem. Hysteresis creates two switching thresholds (one for the rising input voltage and the other for the falling input voltage). Hysteresis is the voltage difference between the two switching thresholds. When both inputs are nearly equal,

hysteresis causes one input to effectively move quickly past the other. Thus, effectively moving the input out of region that oscillation may occur.

Hysteresis can easily be added to a comparator in a non-inverting configuration with two resistors and positive feedback *Figure 3*. The output will switch from low to high when V_{IN} rises up to V_{IN1} , where V_{IN1} is calculated by

$$V_{IN1} = (V_{REF} (R1 + R2)) / R2$$

The output will switch from high to low when V_{IN} falls to V_{IN2} , where V_{IN2} is calculated by

$$V_{IN2} = (V_{REF} (R1 + R2) - V_{CC} R1) / R2$$

The Hysteresis is the difference between V_{IN1} and V_{IN2} .

$$\Delta V_{IN} = V_{IN1} - V_{IN2} = ((V_{REF} (R1 + R2)) / R2) - ((V_{REF} (R1 + R2) - V_{CC} R1) / R2) = V_{CC} R1 / R2.$$

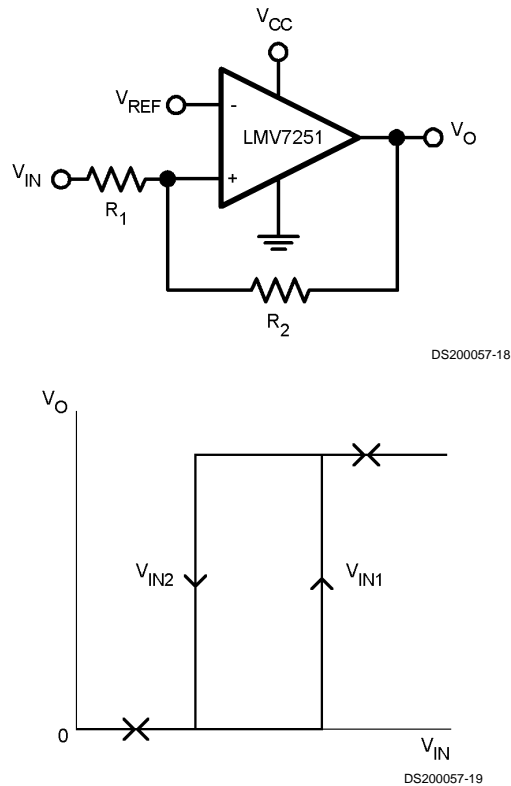

FIGURE 3. Non-Inverting Comparator Configuration — LMV7251

For an inverting configured comparator, hysteresis can be added with a three resistor network and positive feedback. When input voltage (V_{IN}) at the inverting node is less than non-inverting node (V_T), the output is high. The equivalent circuit for the three resistor network is $R1$ in parallel with $R3$ and in series with $R2$. The lower threshold voltage V_{T1} is calculated by:

$$V_{T1} = ((V_{CC} R2) / ((R1 R3) / (R1 + R3)) + R2)$$

When V_{IN} is greater than V_T , the output voltage is low. The equivalent circuit for the three resistor network is $R2$ in parallel with $R3$ and in series with $R1$. The upper threshold voltage V_{T2} is calculated by:

$$V_{T2} = V_{CC} ((R2 R3) / (R2 + R3)) / ((R1 + ((R2 R3) / (R2 + R3)))$$

The hysteresis is defined as

$$\Delta V_{IN} = V_{T1} - V_{T2} = ((V_{CC} R2) / ((R1 R3) / (R1 + R3)) + R2) - (V_{CC} ((R2 R3) / (R2 + R3)) / ((R1 + ((R2 R3) / (R2 + R3))))$$

Application Info (Continued)

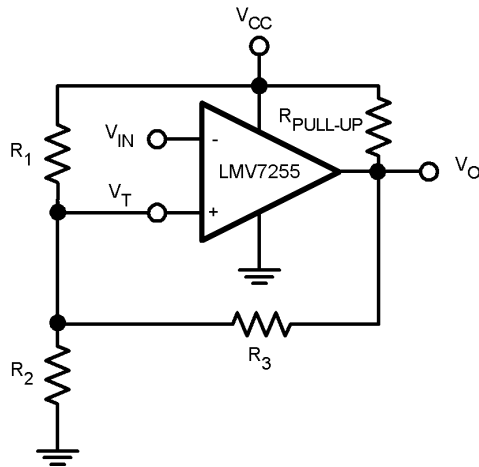

DS200057-20

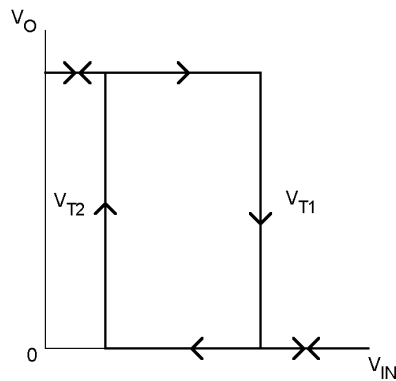

DS200057-21

FIGURE 4. Inverting Configured Comparator — LMV7255

Input Stage

The LMV7251 and LMV7255 have rail-to-rail input stages. The input common mode voltage range is from -100mV to $(V_{CC} + 100\text{mV})$.

Output Stage

The LMV7251 has a push-pull CMOS output stage. Large push-pull output drivers allows rail-to-rail output swings with load currents in the milliampere range.

The LMV7255 has an open drain CMOS output stage. This requires an external pull-up resistor connected between the positive supply voltage and the output. The external pull-up resistor should be high enough resistance so to avoid excessive power dissipation. In addition, the pull-up resistor should be low enough resistance to enable the comparator to switch with the load circuitry connected.

Power Supply Considerations

The LMV7251/LMV7255 are well suited for many battery-powered applications. The LMV7251/LMV7255 can operate from single power supply of $+1.8\text{V}$ to $+5\text{V}$. The device typically consumes only $11\mu\text{A}$ with a 2.7V supply. With a high power supply rejection ratio (PSRR) of 79 dB (typical), the comparator is well suited for operating under conditions of a decaying battery voltage.

Power supply decoupling is critical and improves stability. Place decoupling capacitors $0.1\mu\text{F}$ as close as possible to the V^+ pin. For split supply applications, place decoupling capacitors $0.1\mu\text{F}$ on both the V^+ and V^- pins. The decoupling capacitors will help keep the comparator from oscillating under various load conditions.

Ordering Information

Package	Ordering Info	Pkg Marking	Supplied As	NSC Drawing
5-Pin SOT23-5	LMV7251M5	C16A	1k Units Tape and Reel	MF05A
	LMV7251M5X	C16A	3k units Tape and Reel	
	LMV7255M5	C18A	1k Units Tape and Reel	
	LMV7255M5X	C18A	3k units Tape and Reel	
5-Pin SC-70	LMV7251M7	C17	1k Units Tape and Reel	MAA05A
	LMV7251M7X	C17	3k units Tape and Reel	
	LMV7255M7	C19	1k Units Tape and Reel	
	LMV7255M7X	C19	3k units Tape and Reel	

Physical Dimensions inches (millimeters) unless otherwise noted

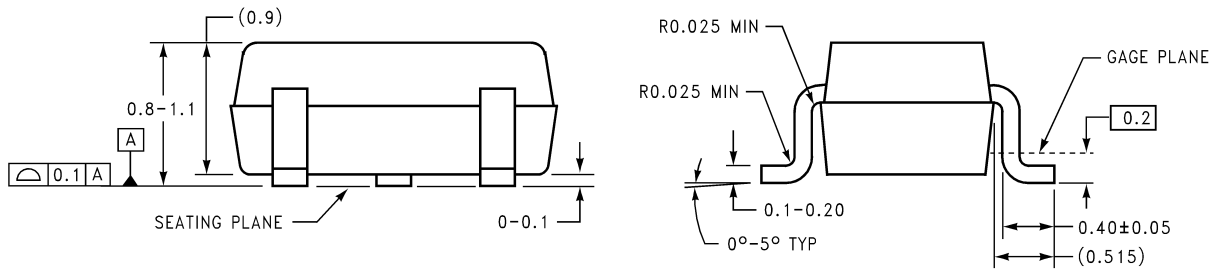
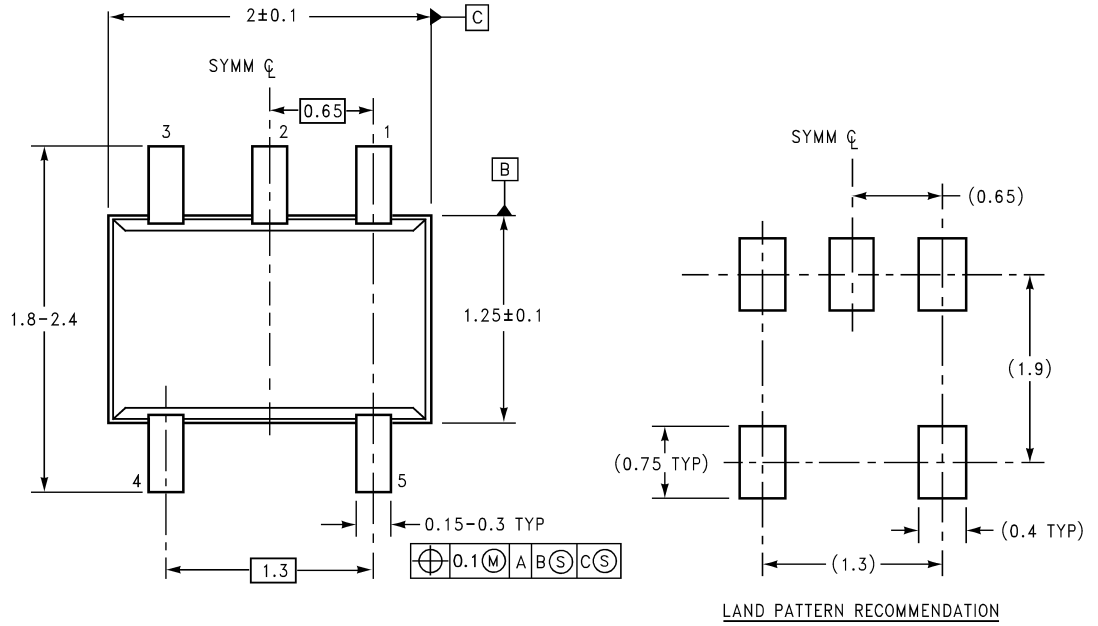

DIMENSIONS ARE IN MILLIMETERS

MAA05A (REV B)

5-Pin SC70-5
NS Package Number MAA05A

Physical Dimensions inches (millimeters) unless otherwise noted

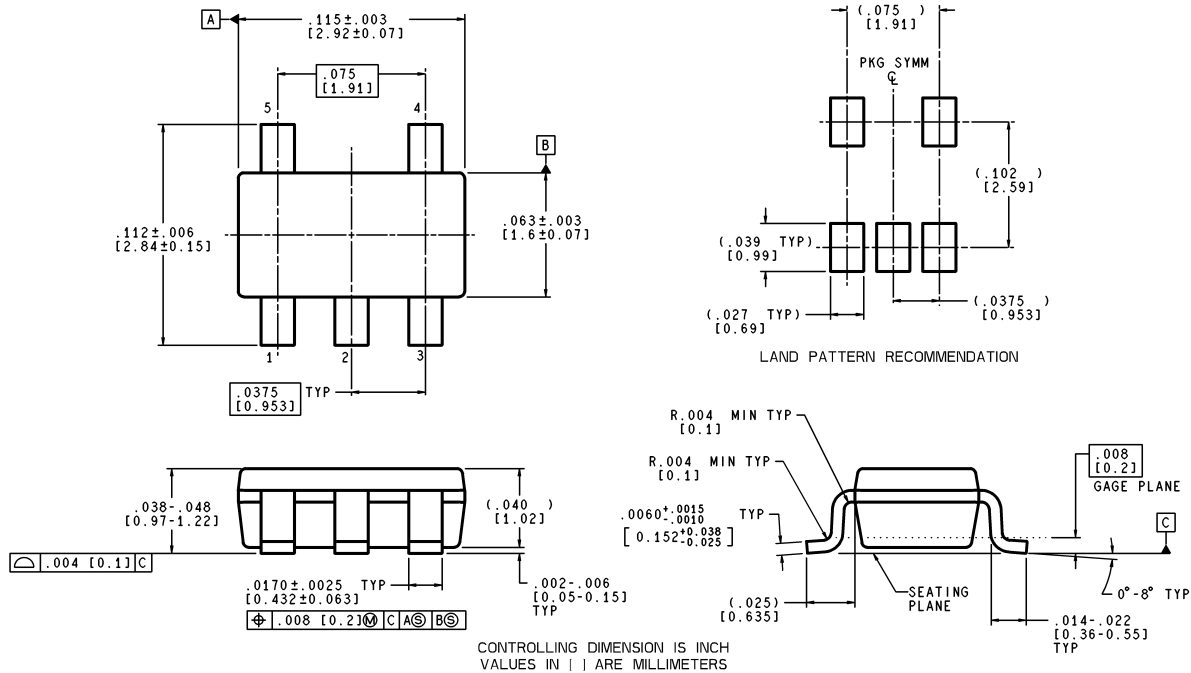

MF05A (Rev A)

**5-Pin SOT23-5
NS Package Number MF05A**

LIFE SUPPORT POLICY

NATIONAL'S PRODUCTS ARE NOT AUTHORIZED FOR USE AS CRITICAL COMPONENTS IN LIFE SUPPORT DEVICES OR SYSTEMS WITHOUT THE EXPRESS WRITTEN APPROVAL OF THE PRESIDENT AND GENERAL COUNSEL OF NATIONAL SEMICONDUCTOR CORPORATION. As used herein:

1. Life support devices or systems are devices or systems which, (a) are intended for surgical implant into the body, or (b) support or sustain life, and whose failure to perform when properly used in accordance with instructions for use provided in the labeling, can be reasonably expected to result in a significant injury to the user.
2. A critical component is any component of a life support device or system whose failure to perform can be reasonably expected to cause the failure of the life support device or system, or to affect its safety or effectiveness.

National Semiconductor Corporation
Americas
Tel: 1-800-272-9959
Fax: 1-800-737-7018
Email: support@nsc.com
www.national.com

National Semiconductor Europe
Fax: +49 (0) 180-530 85 86
Email: europe.support@nsc.com
Deutsch Tel: +49 (0) 69 9508 6208
English Tel: +44 (0) 870 24 0 2171
Français Tel: +33 (0) 1 41 91 8790

National Semiconductor Asia Pacific Customer Response Group
Tel: 65-2544466
Fax: 65-2504466
Email: ap.support@nsc.com

National Semiconductor Japan Ltd.
Tel: 81-3-5639-7560
Fax: 81-3-5639-7507