

# AN6182K, AN6182S

## Recording and playing amplifier IC for answering telephones

### Overview

The AN6182K and AN6182S are recording and playing amplifier ICs for answering telephones. They incorporate an ALC circuit, recording and playing amplifiers, a loudspeaker amplifier, and a VOX circuit.

### Features

- Incorporates recording and playing amplifiers.
- Incorporates a loudspeaker amplifier.
- Incorporates a VOX circuit.
- Incorporates a magnetic-head circuit to provide for one-tape cassette recording.
- Incorporates 4 control circuits.

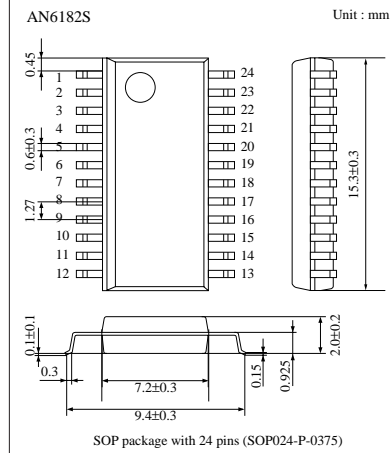
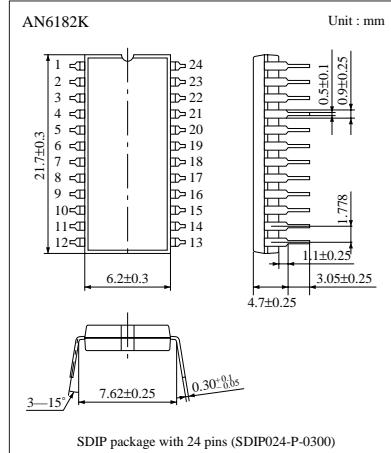

### Block Diagram

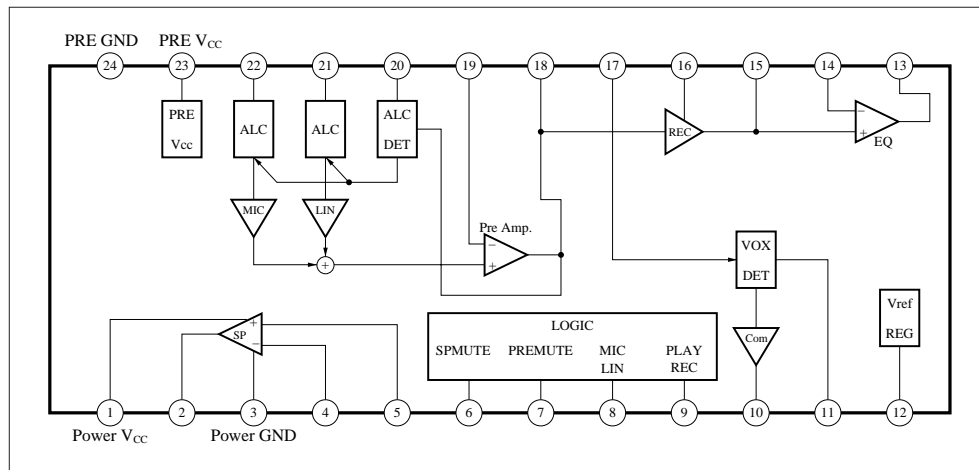

## ■ Absolute Maximum Ratings (Ta=25°C)

| Parameter                            | Symbol           | Rating       | Unit |
|--------------------------------------|------------------|--------------|------|
| Supply voltage <sup>Note 1)</sup>    | V <sub>CC</sub>  | 9.0          | V    |
| Supply current <sup>Note 1)</sup>    | I <sub>CC</sub>  | 600          | mA   |
| Power dissipation <sup>Note 2)</sup> | AN6182K          | 700          | mW   |
|                                      | AN6182S          | 338          | mW   |
| Operating ambient temperature        | T <sub>opr</sub> | -20 to + 75  | °C   |
| Storage temperature                  | AN6182K          | -55 to + 150 | °C   |
|                                      | AN6182S          | -55 to + 125 | °C   |

Note 1) The IC must be used under the condition  $V_{CC} \times I_{CC} < P_D$ .

Note 2) Ta=60°C

## ■ Operating Supply Voltage Range

| Parameter                      | Symbol          | Range       |
|--------------------------------|-----------------|-------------|
| Operating supply voltage range | V <sub>CC</sub> | 4.5 to 9.6V |

## ■ Electrical Characteristics

| Parameter                         | Symbol               | Condition   | min   | typ   | max   | Unit  |
|-----------------------------------|----------------------|---|-------|-------|-------|-------|
| MIC preamp. gain                  | G <sub>V</sub>       | Vi=-64dBm   | 48.5  | 50.5  | 52.5  | dB    |
| MIC preamp. ALC output            | V <sub>O</sub>       | Vi=-30dBm   | -11   | -9    | -7    | dBm   |
| MIC preamp. output noise voltage  | V <sub>no</sub>      | DIN/AUDIO, Rg=10kΩ  | —     | 1.2   | 2.5   | mVrms |
| LIN preamp. gain                  | G <sub>V</sub>       | Vi=-64dBm   | 48.5  | 50.5  | 52.5  | dB    |
| LIN preamp. ALC output            | V <sub>O</sub>       | Vi=-30dBm   | -11   | -9    | -7    | dBm   |
| LIN preamp. output noise voltage  | V <sub>no</sub>      | DIN/AUDIO, Rg=10kΩ  | —     | 1.2   | 2.5   | mVrms |
| VOX sensitivity (1)               | V <sub>S1</sub>      | Vi=-35dBm   | 3.5   | 4.8   | —     | V     |
| VOX sensitivity (2)               | V <sub>S2</sub>      | Vi=-29dBm   | —     | 0.025 | 0.5   | V     |
| REC head drive                    | G <sub>V</sub>       | Rg=1kΩ, Vi=-10dBm   | -18.7 | -16.2 | -13.7 | dBm   |
| PRAY/EQ amp. gain                 | G <sub>V</sub>       | Vi=-60dBm   | 39.5  | 41.5  | 43.5  | dB    |
| PRAY/EQ amp. output noise voltage | V <sub>no</sub>      | DIN/AUDIO, Rg=10kΩ  | —     | 0.3   | 1.2   | mVrms |
| POWER amp. gain                   | G <sub>V</sub>       | Vi=-20dBm   | 14.5  | 17    | 19.5  | dB    |
| POWER amp. max output voltage     | V <sub>O</sub>       | R <sub>L</sub> =8Ω, THD=5%  | 100   | 200   | —     | mW    |
| POWER amp. output noise voltage   | V <sub>no</sub>      | DIN/AUDIO, Rg=10kΩ  | —     | 0.2   | 1.0   | mVrms |
| Pre. V <sub>CC</sub> voltage      | V <sub>CC</sub>      | No signal, V <sub>CC</sub> =5V                                    | 3.6   | 4.0   | 4.4   | V     |
| ΔPRE V <sub>CC</sub> voltage      | V <sub>CC</sub>      | No signal, V <sub>CC</sub> =5V<br>I <sub>CC (PRE)</sub> =0 to 6mA | -0.25 | -0.07 | 0.1   | V     |
| Total circuit current (1)         | I <sub>total-1</sub> | No signal<br>recording mode (SP ON)                               | 12    | 20    | 30    | mA    |
| Total circuit current (2)         | I <sub>total-2</sub> | No signal<br>recording mode (SP OFF)                              | 2     | 3.3   | 5     | mA    |

## ■ Pin Descriptions

| Pin No. | Symbol               | Description   |
|---------|----------------------|---|
| 1       | Power $V_{CC}$       | Loudspeaker amplifier power supply input<br>An external power supply connects to this pin. The input supply voltage range is 4.5 to 9V.   |
| 2       | Power out            | Loudspeaker amplifier output<br>This pin connects through an electrolytic capacitor to a loudspeaker with a load impedance of 8 $\Omega$ or more. This pin is effective only when Pin6 is high.   |
| 3       | Power GND            | Loudspeaker amplifier ground<br>This pin connects to an external ground. This ground should be separated from that of the preamplifier circuits.  |
| 4       | Power NF             | Loudspeaker amplifier inverse input<br>A combination of resistors and a capacitor connected between this pin and Pin2 and the ground determines the gain and frequency characteristics of the loudspeaker amplifier.  |
| 5       | Power in             | Loudspeaker amplifier non-inverse input<br>Signals should be input to this pin through a capacitor. The expected input impedance is typically 27k $\Omega$ .  |
| 6       | SP mute control      | Loudspeaker amplifier mute control<br>If the voltage level at this pin is high, the loudspeaker amplifier turns ON, and if low, turns OFF.  |
| 7       | Preamp. mute control | Preamplifier mute control<br>If the voltage level at this pin is high, the preamplifier turns OFF, thereby blocking the MIC and line preamplifier outputs. If the voltage is low, the preamplifier turns ON. Even if the preamplifier is turned OFF (mute ON), signals input to Pin9 are output from Pin18.     |
| 8       | MIC/LIN control      | MIC/line preamplifier switching<br>If the input to Pin7 is low and the input to this pin is high, then the line preamplifier turns ON and the MIC preamplifier turns OFF. If the input to Pin7 is low and the input to this pin is low, then the line preamplifier turns OFF and the MIC preamplifier turns ON. |
| 9       | REC/PLAY control     | REC/PLAY switching<br>If the input to this pin is high, the recording amplifier turns OFF, and the play equalizer amplifier turns ON. If low, the recording amplifier turns ON, and the play equalizer amplifier turns OFF.   |
| 10      | VOX out              | VOX output<br>The VOX detection signal is output from this pin. This pin should be connected through a resistor (100-200k $\Omega$ ) to the power supply.   |
| 11      | VOX DET              | VOX detection control<br>This pin should be connected through a resistor (10 to 470k $\Omega$ ) and a capacitor in parallel to the ground. The resistance determines the sensitivity of VOX detection.  |
| 12      | $V_{REF}$            | Internal reference supply voltage output<br>This pin should be grounded through a 100 $\mu$ F capacitor.  |
| 13      | EQ-amp. out          | Equalizer amplifier output<br>Amplified play signals from the head are output from this pin. A resistor and capacitors connected between this pin and Pin14 determine the equalizer characteristics.  |
| 14      | EQ-amp. NF           | Equalizer amplifier inverse input<br>This pin connects through a resistor to Pin13 to determine the equalizer characteristics. The expected input impedance is typically 10k $\Omega$ .   |
| 15      | Head in/out          | To the REC/PLAY head<br>A REC/PLAY head must be connected between this pin and the ground. Switching of REC and PLAY modes is done by Pin9. A load resistor should be connected between this pin and the ground because the input impedance becomes high (several hundred kilohms) in the PLAY mode.            |
| 16      | REC ADJ              | REC gain control<br>A resistance connected between this pin and the ground determines the head bias current in the REC mode. The lower the resistance, the higher the current. A serial combination of a resistance and a capacitance, connected in parallel with the resistance, determines the REC gain.      |
| 17      | VOX in               | VOX amplifier input<br>The preamplifier output at Pin18 must be connected through a resistor and a capacitor to this pin. The impedance between Pin18 and this pin determines the gain, and a resistance between Pin11 and the ground determines the frequency characteristics of the VOX amplifier.            |
| 18      | Pre out              | Preamplifier output<br>Amplified MIC/line preamplifier outputs are output from this pin depending on the statuses of Pin7 (preamplifier mute) and Pin8 (MIC/line switching).  |
| 19      | Pre NF               | Preamplifier inverse input<br>Resistors and a capacitor connected between this pin and Pin18 and 12 determine the preamplifier gain. The input impedance at this pin is several hundred kilohms.  |
| 20      | ALC DET              | ALC detection control<br>A 240k $\Omega$ resistor and a 4.7 $\mu$ F capacitor connected in parallel between this pin and the ground control ALC detection sensitivity.  |

## ■ Pin Descriptions (cont.)

| Pin No. | Symbol              | Description   |
|---------|---------------------|---|
| 21      | LIN in              | Line preamplifier input<br>Line receiver signals are input through a capacitor and a resistor to this pin, and then amplified to be output from Pin18. The statuses of Pins7 and 8 enable or disable the signals. The input impedance with ALC OFF is 10kΩ. |
| 22      | MIC in              | MIC preamplifier input<br>MIC signals are input through a capacitor and a resistor to this pin, and then amplified to be output from Pin18. The statuses of Pins7 and 8 enable or disable the signals. The input impedance with ALC OFF is 10kΩ.            |
| 23      | PRE V <sub>CC</sub> | Preamplifier internal regulated supply voltage output<br>This pin should be grounded through a 220μF capacitor. The output voltage is typically 4.2V. The output can be used as an ECM bias current source.   |
| 24      | PRE GND             | Preamplifier ground<br>This is the ground pin for the preamplifier circuits.  |

## ■ Pin Descriptions

| Pin No. | Description                               | Pin No. | Description   |
|---------|---|---------|---|
| 1       | Loudspeaker amplifier power supply input  | 13      | Equalizer amplifier output                            |
| 2       | Loudspeaker amplifier output              | 14      | Equalizer amplifier inverting input                   |
| 3       | Loudspeaker amplifier ground              | 15      | To the REC/PLAY head                                  |
| 4       | Loudspeaker amplifier inverse input       | 16      | REC gain control                                      |
| 5       | Loudspeaker amplifier non-inverting input | 17      | VOX amplifier input                                   |
| 6       | Loudspeaker amplifier mute control        | 18      | Preamplifier output                                   |
| 7       | Preamplifier mute control                 | 19      | Preamplifier inverting input                          |
| 8       | MIC/line preamplifier switching           | 20      | ALC detection control                                 |
| 9       | REC/PLAY switching                        | 21      | Line preamplifier input                               |
| 10      | VOX output                                | 22      | MIC preamplifier input                                |
| 11      | VOX detection control                     | 23      | Preamplifier internal regulated supply voltage output |
| 12      | Internal reference supply voltage output  | 24      | Preamplifier ground                                   |

■ Block Diagram Showing the Logic of Amplifies

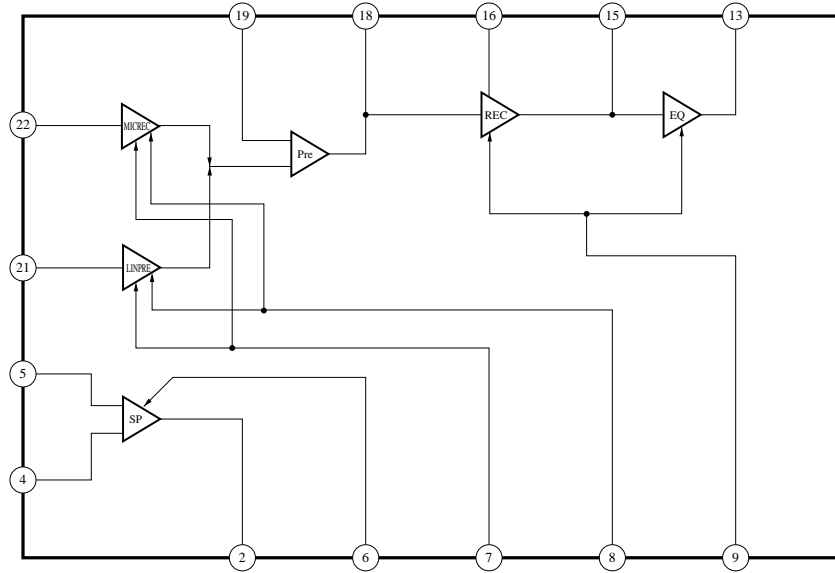

1. Loudspeaker amplifier mute

| 6 SP MUTE | SP POWER |
|-----------|----------|
| H         | ON       |
| L         | OFF      |

2. REC/PLAY switching

| 9 PLAY/REC | REC | EQ  |
|------------|-----|-----|
| H          | OFF | ON  |
| L          | ON  | OFF |

3. Preamplifiers switching

| 9 PRE AMP | iMIC/LIN | MIC PRE AMP | LIN PRE AMP |
|-----------|----------|-------------|-------------|
| H         | —        | OFF         | OFF         |
| L         | H        | OFF         | ON          |
| L         | L        | ON          | OFF         |

■ Application Circuit

