

# AN6167S, AN6167SB

## Cordless Telephone Speech Network IC

### ■ Overview

The AN6167S and AN6167SB are speech network ICs for the handset of a cordless telephone. They incorporate compressor, MIC, and receiver amplifiers. With a minimal number of external components, they can perform all the functions of the handset of a cordless telephone featuring low radio-transmission noise.

### ■ Features

- The compressor/expander circuit incorporates preamplifiers to make level and frequency adjustments easier.
- The standby circuit provides for a low-power consumption cordless telephone.
- The expander has a 6-dB amplifier to allow received-signal amplification.
- SOP package with 1.27mm pitch pins, and USO package with 0.8mm pitch pins.

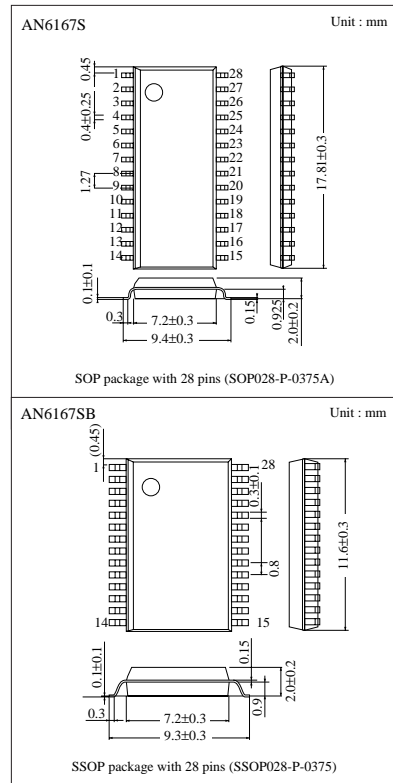

### ■ Block Diagram

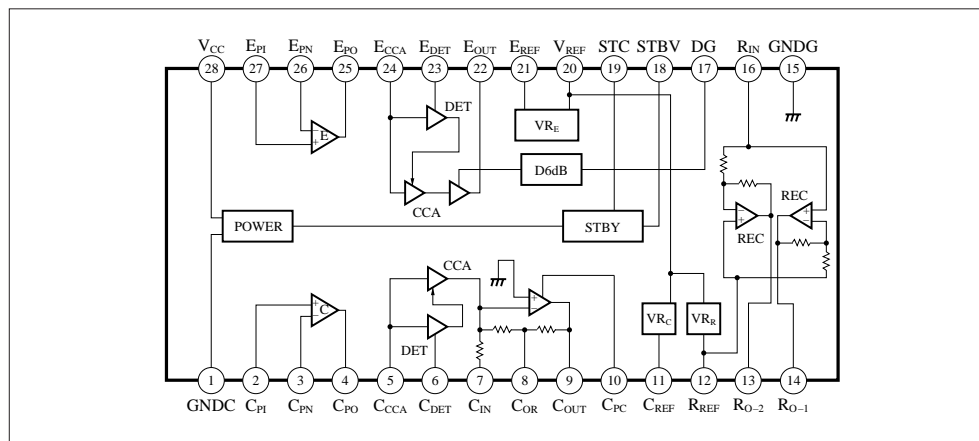

## ■ Absolute Maximum Ratings (Ta=25°C)

Parameter	Symbol	Rating	Unit
Supply voltage	V <sub>CC</sub>	7.5	V
Input supply voltage	V <sub>in</sub>	-0.3 to V <sub>CC</sub> + 0.3	V
Output supply voltage	V <sub>out</sub>	-0.3 to V <sub>CC</sub> + 0.3	V
Power dissipation (Ta = 75°C)	P <sub>D</sub>	280	mW
Operating ambient temperature	T <sub>opr</sub>	-20 to +75	°C
Storage temperature	T <sub>stg</sub>	-55 to +150	°C

## ■ Recommended Operating Range (Ta=25°C)

Parameter	Symbol	Range
Operating supply voltage range	V <sub>CC</sub>	2 to 5V

## ■ Electrical Characteristics (Ta=25°C)

Parameter	Symbol	Condition	min	typ	max	Unit
<b>Compressor</b>						
Preamplifier voltage gain	G <sub>PC</sub>	RA/RB=51kΩ/5.1kΩ, V <sub>in</sub> =-40dBV	20	21	22	dB
Preamplifier output voltage	V <sub>PC</sub>	RA/RB=51kΩ/5.1kΩ, THD=5%, R <sub>L</sub> =1kΩ	-10	-7	—	dBV
Reference output	V <sub>ORC</sub>	V <sub>IRC</sub> =-20dBV (Ref. output)	-13	-11	-9	dBV
Δ Gain (1)	ΔC <sub>1</sub>	V <sub>in</sub> =V <sub>IRC</sub> -20dB, ΔC <sub>1</sub> =V <sub>ORC</sub> -V <sub>OC1</sub>	-11	-10	-9	dB
Δ Gain (2)	ΔC <sub>2</sub>	V <sub>in</sub> =V <sub>IRC</sub> -40dB, ΔC <sub>2</sub> =V <sub>ORC</sub> -V <sub>OC2</sub>	-22	-20	-19	dB
Distortion	THD <sub>C</sub>	V <sub>in</sub> =-20dBV	—	0.5	1	%
Maximum output voltage	V <sub>OCM</sub>	THD=5%, R <sub>L</sub> =1kΩ	-10	-7	—	dBV
Output noise voltage	V <sub>NOC</sub>	R <sub>g</sub> =2kΩ with a CCITT filter	—	-64	-56	dBV
<b>Expander</b>						
Preamplifier voltage gain	G <sub>PE</sub>	RA/RB=51kΩ/5.1kΩ, V <sub>in</sub> =-40dBV	20	21	22	dB
Preamplifier output voltage	G <sub>PE</sub>	RA/RB=51kΩ/5.1kΩ, THD=5%, R <sub>L</sub> =1kΩ	-10	-7	—	dBV
Reference output	V <sub>ORE</sub>	V <sub>IRE</sub> =-20dBV (Ref. output)	-32	-29	-26	dBV
Δ Gain (1)	ΔE <sub>1</sub>	V <sub>in</sub> =V <sub>IRC</sub> -10dB, ΔE <sub>1</sub> =V <sub>ORE</sub> -V <sub>OE1</sub>	-21	-20	-19	dB
Δ Gain (2)	ΔE <sub>2</sub>	V <sub>in</sub> =V <sub>IRC</sub> -20dB, ΔE <sub>2</sub> =V <sub>ORE</sub> -V <sub>OE2</sub>	-41.5	-40	-38.5	dB
Distortion	THD <sub>E</sub>	V <sub>in</sub> =-20dBV	—	0.5	1	%
Maximum output voltage	V <sub>OFM</sub>	THD=5%, R <sub>L</sub> =1kΩ	-10	-7	—	dBV
Output noise voltage	V <sub>NOE</sub>	R <sub>g</sub> =2kΩ with a CCITT filter	—	-95	-90	dBV
Receiver amp. gain	ΔG <sub>E</sub>	Pin17 ON [GND]	4	6	8	dB
<b>Receiver amplifier</b>						
Receiver voltage characteristics	G <sub>VR</sub>	V <sub>in</sub> =-30dB, R <sub>L</sub> =1kΩ	18	20	22	dB
Maximum output voltage	V <sub>OEM</sub>	THD=5%, R <sub>L</sub> =1kΩ	2	5	—	dBV
<b>Power supply</b>						
Current consumption	I <sub>CC</sub>	V <sub>CC</sub> =3V, no signal	3	5	8	mA
Receiver voltage characteristics	I <sub>SC</sub>	Standby pin (H)	—	1	10	μA

## Pin Descriptions

Pin No.	Symbol	Description	Pin No.	Symbol	Description
1	GNDC	Compander GND	15	GNDR	REC GND
2	C <sub>PI</sub>	COMP preamp. input (+)	16	R <sub>IN</sub>	REC external signal input
3	C <sub>PN</sub>	COMP preamp. input (-)	17	DG	REC 6-dB amplification
4	C <sub>PO</sub>	COMP preamp. output	18	STBY	Standby
5	C <sub>CCA</sub>	COMP-CCA input	19	STC	Standby adjustment
6	C <sub>DET</sub>	COMP detection	20	V <sub>REF</sub>	Compander V <sub>REF</sub>
7	C <sub>IN</sub>	COMP signal input	21	E <sub>REF</sub>	EXP-V <sub>REF</sub>
8	C <sub>OR</sub>	COMP output V <sub>REF</sub>	22	E <sub>OUT</sub>	EXP output
9	C <sub>OUT</sub>	COMP output	23	E <sub>DET</sub>	EXP detection
10	C <sub>PC</sub>	COMP phase adjustment	24	E <sub>CCA</sub>	EXP-CCA input
11	C <sub>REF</sub>	COMP-V <sub>REF</sub>	25	E <sub>PO</sub>	EXP preamp. output
12	R <sub>REF</sub>	REC-V <sub>REF</sub>	26	E <sub>PN</sub>	EXP preamp. input (-)
13	R <sub>O-2</sub>	REC output (2)	27	E <sub>PI</sub>	EXP preamp. input (+)
14	R <sub>O-1</sub>	REC output (1)	28	V <sub>CC</sub>	Supply voltage

## Application Circuit

