

INA106

Precision Gain = 10 DIFFERENTIAL AMPLIFIER

FEATURES

- ACCURATE GAIN: $\pm 0.025\%$ max
- HIGH COMMON-MODE REJECTION: 86dB min
- NONLINEARITY: 0.001% max
- EASY TO USE
- PLASTIC 8-PIN DIP, SO-8 SOIC PACKAGES

APPLICATIONS

- G = 10 DIFFERENTIAL AMPLIFIER
- G = +10 AMPLIFIER
- G = -10 AMPLIFIER
- G = +11 AMPLIFIER
- INSTRUMENTATION AMPLIFIER

DESCRIPTION

The INA106 is a monolithic Gain = 10 differential amplifier consisting of a precision op amp and on-chip metal film resistors. The resistors are laser trimmed for accurate gain and high common-mode rejection. Excellent TCR tracking of the resistors maintains gain accuracy and common-mode rejection over temperature.

The differential amplifier is the foundation of many commonly used circuits. The INA106 provides this precision circuit function without using an expensive resistor network. The INA106 is available in 8-pin plastic DIP and SO-8 surface-mount packages.

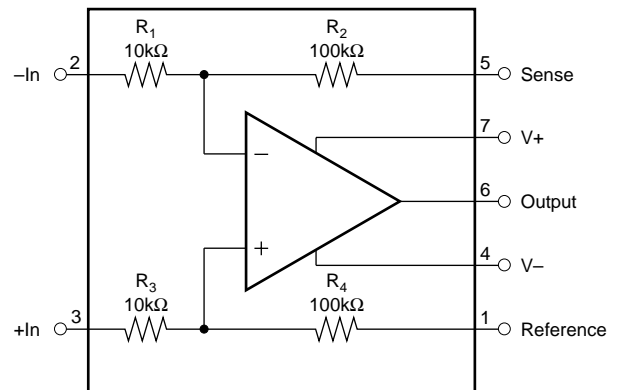

SPECIFICATIONS

ELECTRICAL

At +25°C, $V_S = \pm 15V$, unless otherwise specified.

PARAMETER	CONDITIONS	INA106KP, U			UNITS
		MIN	TYP	MAX	
GAIN Initial ⁽¹⁾ Error vs Temperature Nonlinearity ⁽²⁾			10 0.01 -4 0.0002	0.025	V/V % ppm/°C %
OUTPUT Related Voltage Rated Current Impedance Current Limit Capacitive Load	$I_O = +20mA, -5mA$ $V_O = 10V$ To Common Stable Operation	10 +20, -5	12 0.01 +40/-10 1000		V mA Ω mA pF
INPUT Impedance Voltage Range Common-Mode Rejection ⁽³⁾	Differential Common-Mode Differential Common-Mode $T_A = T_{MIN}$ to T_{MAX}		10 110 86		k Ω k Ω V V dB
OFFSET VOLTAGE Initial vs Temperature vs Supply vs Time	RTI ⁽⁴⁾ $\pm V_S = 6V$ to $18V$		50 0.2 1 10	200 10	μV $\mu V/^\circ C$ $\mu V/V$ $\mu V/mo$
NOISE VOLTAGE $f_B = 0.01Hz$ to $10Hz$ $f_O = 10kHz$	RTI ⁽⁵⁾		1 30		$\mu Vp-p$ nV/ \sqrt{Hz}
DYNAMIC RESPONSE Small Signal Full Power BW Slew Rate Settling Time: 0.1% 0.01% 0.01%	-3dB $V_O = 20Vp-p$ $V_O = 10V$ Step $V_O = 10V$ Step $V_{CM} = 10V$ Step, $V_{DIFF} = 0V$	30 2	5 50 3 5 10 5		MHz kHz V/ μs μs μs μs
POWER SUPPLY Rated Voltage Range Quiescent Current	Derated Performance $V_O = 0V$	± 5	± 15 ± 1.5	± 18 ± 2	V V mA
TEMPERATURE RANGE Specification Operation Storage		0 -40 -65		+70 +85 +150	°C °C °C

NOTES: (1) Connected as difference amplifier (see Figure 1). (2) Nonlinearity is the maximum peak deviation from the best-fit straight line as a percent of full-scale peak-to-peak output. (3) With zero source impedance (see "Maintaining CMR" section). (4) Includes effects of amplifiers's input bias and offset currents. (5) Includes effect of amplifier's input current noise and thermal noise contribution of resistor network.

PIN CONFIGURATION

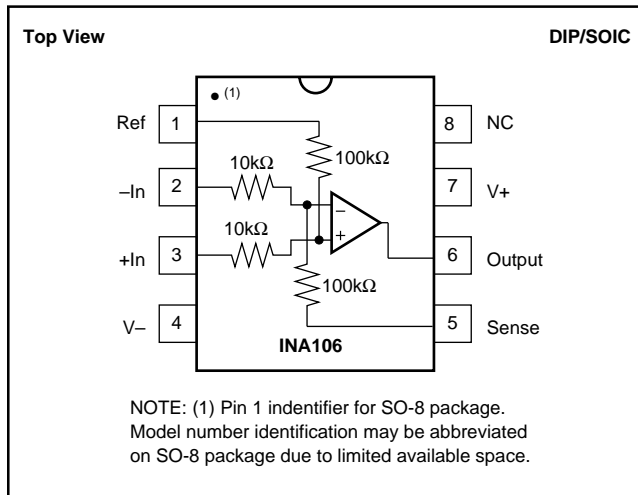

ABSOLUTE MAXIMUM RATINGS

Power Supply Voltage	±18V
Input Voltage Range	±V _S
Operating Temperature Range: P, U	-40°C to +85°C
Storage Temperature Range	-40°C to +85°C
Lead Temperature (soldering, 10s): P	+300°C
Wave Soldering (3s, max) U	+260°C
Output Short Circuit to Common	Continuous

ELECTROSTATIC DISCHARGE SENSITIVITY

This integral circuit can be damaged by ESD. Burr-Brown recommends that all integrated circuits be handled with appropriate precautions. Failure to observe proper handling and installation procedures can cause damage.

ESD damage can range from subtle performance degradation to complete device failure. Precision integrated circuits may be more susceptible to damage because very small parametric changes could cause the device not to meet published specifications.

PACKAGE/ORDERING INFORMATION

PRODUCT	PACKAGE	PACKAGE DRAWING NUMBER ⁽¹⁾	TEMPERATURE RANGE
INA106KP	8-Pin Plastic DIP	006	0°C to +70°C
INA106U	SO-8 Surface Mount	182	0°C to +70°C

NOTE: (1) For detailed drawing and dimension table, please see end of data sheet, or Appendix C of Burr-Brown IC Data Book.

The information provided herein is believed to be reliable; however, BURR-BROWN assumes no responsibility for inaccuracies or omissions. BURR-BROWN assumes no responsibility for the use of this information, and all use of such information shall be entirely at the user's own risk. Prices and specifications are subject to change without notice. No patent rights or licenses to any of the circuits described herein are implied or granted to any third party. BURR-BROWN does not authorize or warrant any BURR-BROWN product for use in life support devices and/or systems.

TYPICAL PERFORMANCE CURVES

At $T_A = +25^\circ\text{C}$, $V_S = \pm 15\text{V}$, unless otherwise noted.

STEP RESPONSE

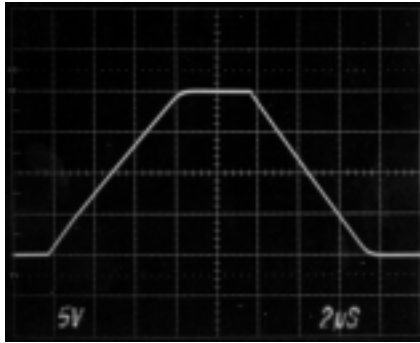

2µs/div

SMALL SIGNAL RESPONSE
(No Load)

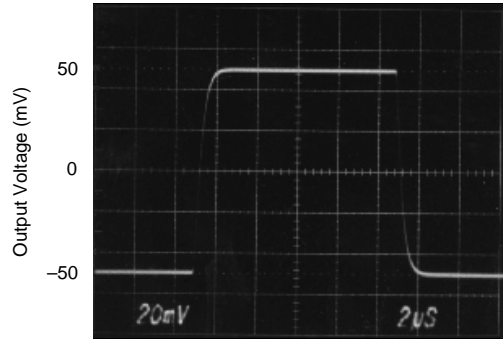

2µs/div

SMALL SIGNAL RESPONSE
($R_{LOAD} = \infty$, $C_{LOAD} = 100\text{pF}$)

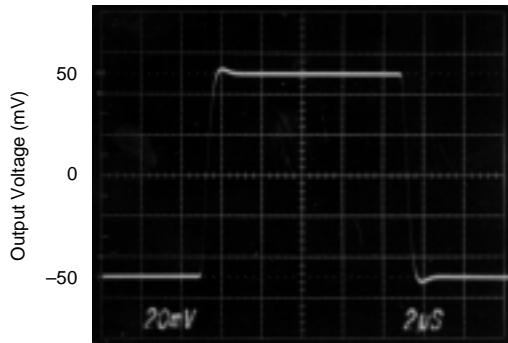

2µs/div

TOTAL HARMONIC DISTORTION AND NOISE
vs FREQUENCY

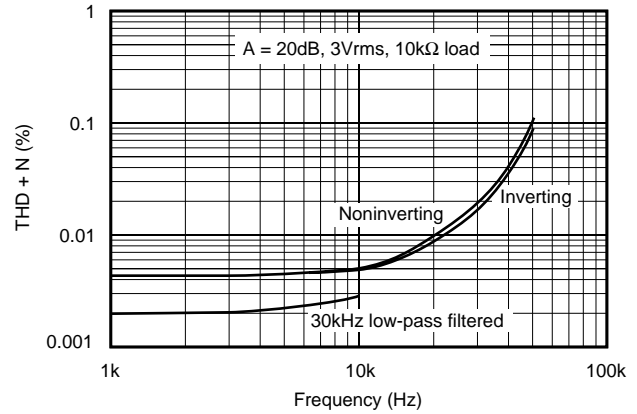

MAXIMUM V_{OUT} vs I_{OUT}
(Negative Swing)

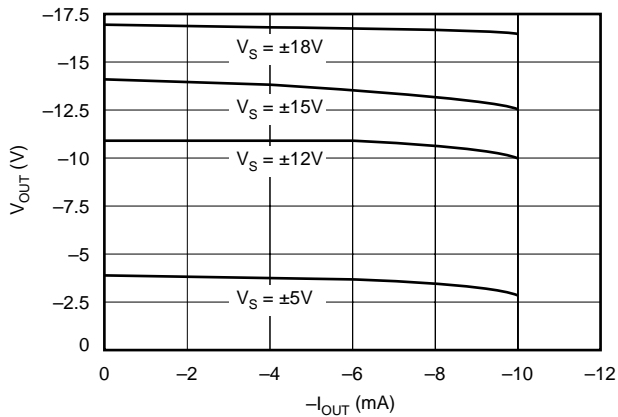

MAXIMUM V_{OUT} vs I_{OUT}
(Positive Swing)

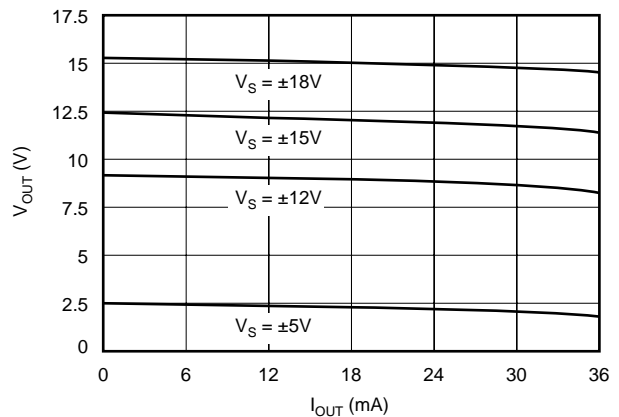

TYPICAL PERFORMANCE CURVES (CONT)

At $T_A = +25^\circ\text{C}$, $V_S = \pm 15\text{V}$, unless otherwise noted.

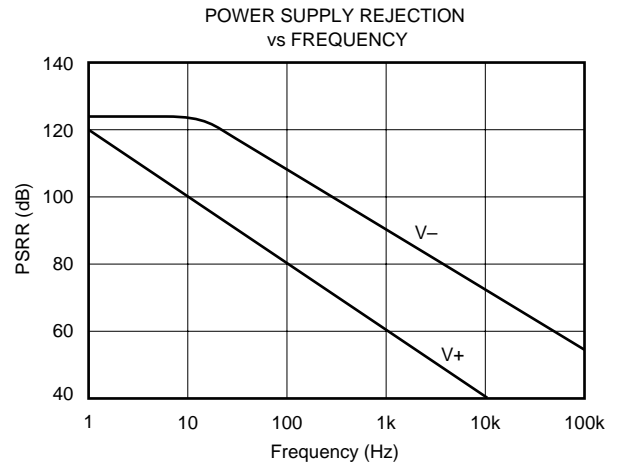
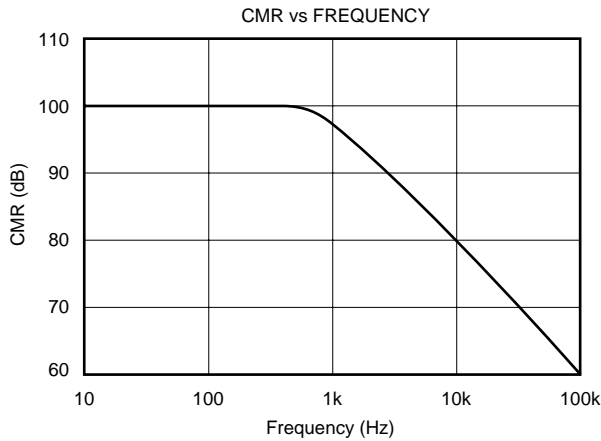

APPLICATIONS INFORMATION

Figure 1 shows the basic connections required for operation of the INA106. Power supply bypass capacitors should be connected close to the device pins as shown.

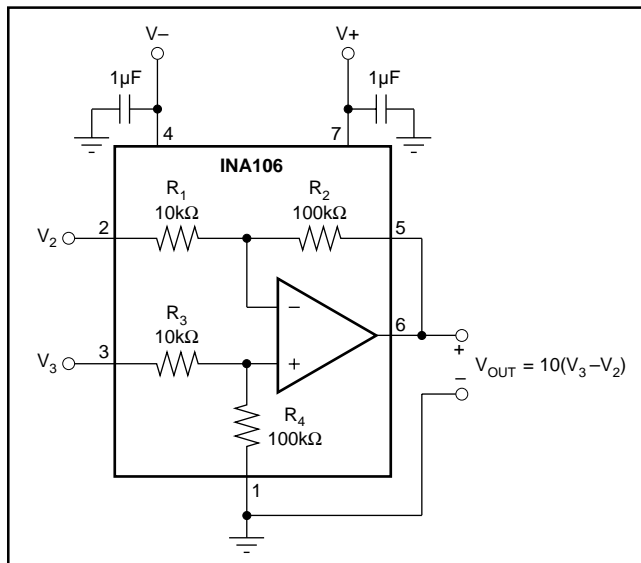

FIGURE 1. Basic Power Supply and Signal Connections.

The differential input signal is connected to pins 2 and 3 as shown. The source impedance connected to the inputs must be equal to assure good common-mode rejection. A 5Ω mismatch in source impedance will degrade the common-mode rejection of a typical device to approximately 86dB. If the source has a known source impedance mismatch, an additional resistor in series with one input can be used to preserve good common-mode rejection.

The output is referred to the output reference terminal (pin 1) which is normally grounded. A voltage applied to the

Ref terminal will be summed with the output signal. The source impedance of a signal applied to the Ref terminal should be less than 10Ω to maintain good common-mode rejection.

Figure 2 shows a voltage applied to pin 1 to trim the offset voltage of the INA106. The known 100Ω source impedance of the trim circuit is compensated by the 10Ω resistor in series with pin 3 to maintain good CMR.

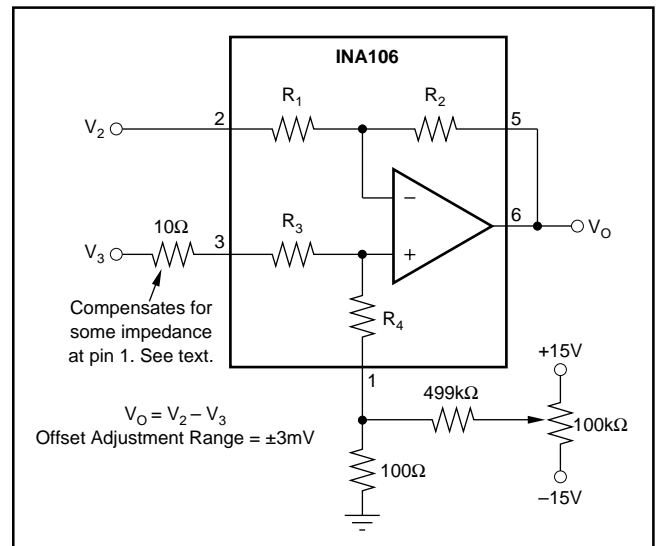

FIGURE 2. Offset Adjustment.

Referring to Figure 1, the CMR depends upon the match of the internal R_4/R_3 ratio to the R_1/R_2 ratio. A CMR of 106dB requires resistor matching of 0.005%. To maintain high CMR over temperature, the resistor TCR tracking must be better than $2\text{ppm}/^\circ\text{C}$. These accuracies are difficult and expensive to reliably achieve with discrete components.

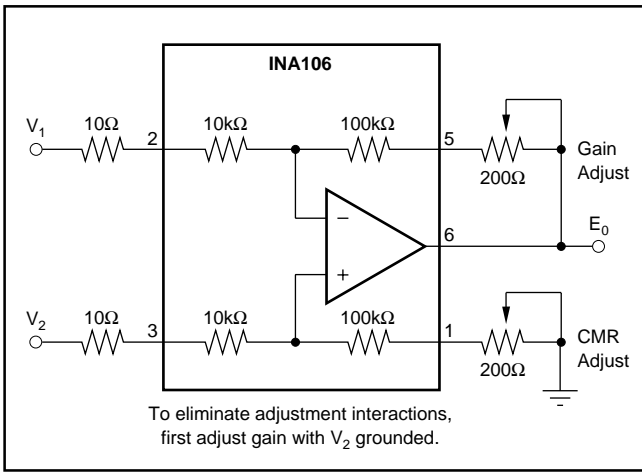

FIGURE 3. Difference Amplifier with Gain and CMR Adjust.

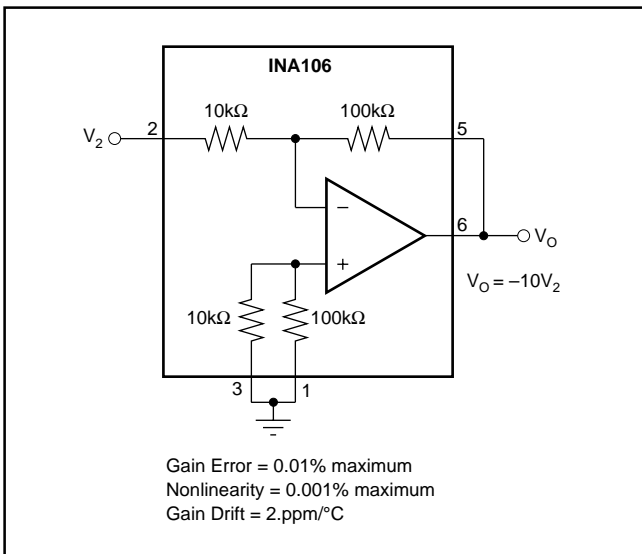

FIGURE 4. Precision $G = -10$ Inverting Amplifier.

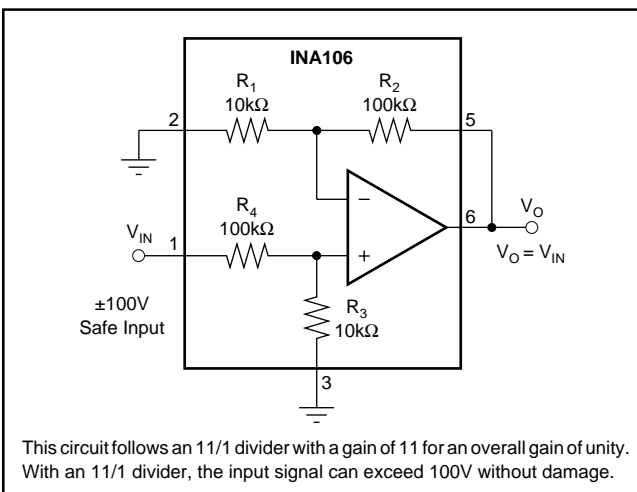
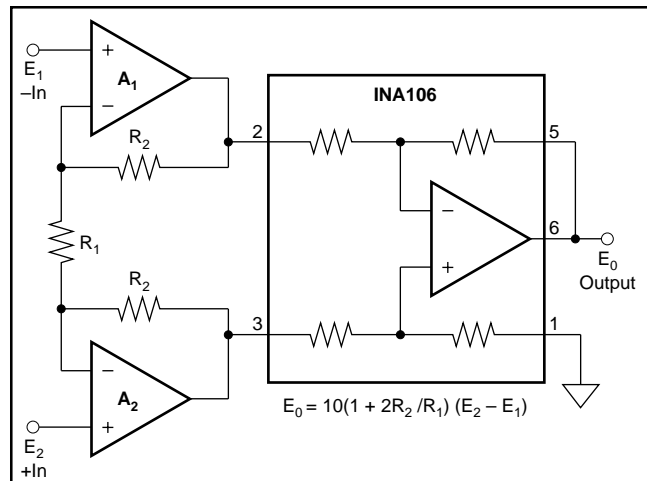

FIGURE 5. Voltage Follower with Input Protection.



To make a high performance high gain instrumentation amplifier, the INA106 can be combined with state-of-the-art op amps. For low source impedance applications, OPA37s will give the best noise, offset, and temperature drift. At source impedances above about 10kΩ, the bias current noise of the OPA37 reacting with input impedance degrades noise. For these applications, use an OPA111 or a dual OPA2111 FET input op amp for lower noise. For an electrometer grade IA, use the OPA128—see table below.

Using the INA106 for the difference amplifier also extends the input common-mode range of the instrumentation amplifier to ±10V. A conventional IA with a unity-gain difference amplifier has an input common-mode range limited to ±5V for an output swing of ±10V. This is because a unity-gain difference amp needs ±5V at the input for 10V at the output, allowing only 5V additional for common-mode.

A_1, A_2	R_1 (Ω)	R_2 (kΩ)	GAIN (V/V)	CMRR (dB)	I_b (pA)	NOISE AT 1kHz (nV/√Hz)
OPA37A	50.5	2.5	1000	128	40000	4
OPA111B	202	10	1000	110	1	10
OPA128LM	202	10	1000	118	0.075	38

FIGURE 6. Precision Instrumentation Amplifier.

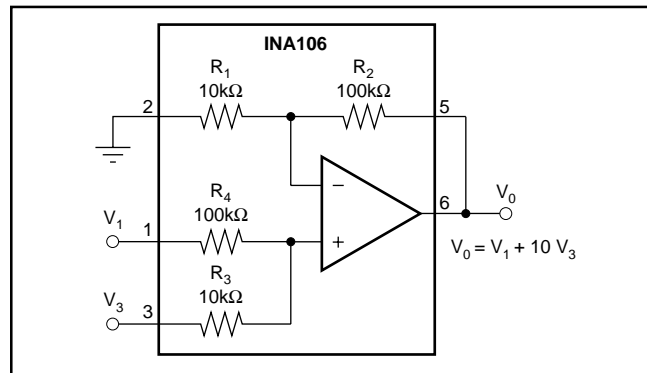

FIGURE 7. Precision Summing Amplifier.

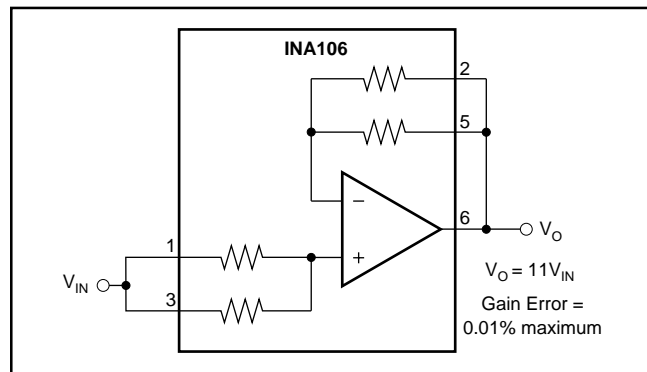

FIGURE 8. Precision $G = 11$ Buffer.