

Features

- Voltage noise of only 4.9nV/√Hz
- Current noise of only 1.2pA/√Hz
- Bandwidth (-3dB) of 80MHz @ $A_V = +1$
- Gain-of-1 stable
- Just 4.5mA per amplifier
- 8-pin MSOP package
- $\pm 2.5V$ to $\pm 12V$ operation

Applications

- ADSL Filters
- HDSLII Filters
- Ultrasound input amplifiers
- Wideband Instrumentation
- Communications equipment
- Wideband sensors

Ordering Information

Part No.	Temp. Range	Package	Outline #
EL2228CY	8-Pin MSOP	-	MDP0043
EL2228CY-T13	8-Pin MSOP	13"	MDP0043
EL2228CY-T7	8-Pin MSOP	7"	MDP0043
EL2228CS	8-Pin SO	-	MDP0027
EL2228CS-T13	8-Pin SO	13"	MDP0027
EL2228CS-T7	8-Pin SO	7"	MDP0027

General Description

The EL2228C is a dual, low-noise amplifier, ideally suited to filtering applications in ADSL and HDSLII designs. It feature low noise specification of just 4.9nV/√Hz and 1.2pA/√Hz, making it ideal for processing low voltage waveforms.

The EL2228C has a -3dB bandwidth of 80MHz and is gain-of-1 stable. It also affords minimal power dissipation with a supply current of just 4.5mA per amplifier. The amplifier can be powered from supplies ranging from $\pm 2.5V$ to $\pm 12V$.

The EL2228C is available in a space saving 8-Pin MSOP package as well as the industry standard 8-Pin SO. It can operate over the $-40^{\circ}C$ to $+85^{\circ}C$ temperature range.

Connection Diagram

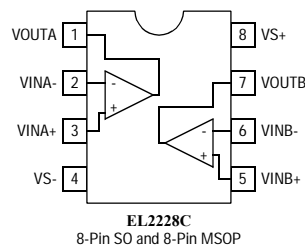

Note: All information contained in this data sheet has been carefully checked and is believed to be accurate as of the date of publication; however, this data sheet cannot be a "controlled document". Current revisions, if any, to these specifications are maintained at the factory and are available upon your request. We recommend checking the revision level before finalization of your design documentation.

EL2228C - Preliminary

Dual Low Noise Amplifier

Absolute Maximum Ratings (T_A = 25°C)

Values beyond absolute maximum ratings can cause the device to be prematurely damaged. Absolute maximum ratings are stress ratings only and functional device operation is not implied.

Supply Voltage between V _{S+} and V _{S-}	+28V
Input Voltage	V _{S-} - 0.3V, V _{S+} + 0.3V
Maximum Continuous Output Current	40mA

Maximum Die Temperature	+125°C
Storage Temperature	-65°C to +150°C
Operating Temperature	-40°C to +85°C
Lead Temperature	260°C
Power Dissipation	See Curves
ESD Voltage	2kV

Important Note:

All parameters having Min/Max specifications are guaranteed. Typ values are for information purposes only. Unless otherwise noted, all tests are at the specified temperature and are pulsed tests, therefore: T_J = T_C = T_A

Electrical Characteristics

V_{S+} = +12V, V_{S-} = -12V, R_L = 500Ω and C_L = 3pF to 0V, R_F = 420Ω & T_A = 25°C unless otherwise specified.

Parameter	Description	Condition	Min	Typ	Max	Unit
Input Characteristics						
V _{OS}	Input Offset Voltage	V _{CM} = 0V		0.2	3	mV
TCV _{OS}	Average Offset Voltage Drift	[1]		-4		μV/°C
I _B	Input Bias Current	V _{CM} = 0V	-9	-4.5	-1	μA
R _{IN}	Input Impedance			8		MΩ
C _{IN}	Input Capacitance			1		pF
CMIR	Common-Mode Input Range		-11.8		+10.4	V
CMRR	Common-Mode Rejection Ratio	for V _{IN} from -11.8V to +10.4V	60	90		dB
		for V _{IN} from -10V to +10V	60	75		dB
A _{VOL}	Open-Loop Gain	-5V ≤ V _{OUT} ≤ 5V	60	75		dB
e _n	Voltage Noise	f = 100kHz		4.9		nV/√Hz
i _n	Current Noise	f = 100kHz		1.2		pA/√Hz
Output Characteristics						
V _{OL}	Output Swing Low	R _L = 500Ω		-10.3	-10	V
		R _L = 250Ω		-9.5	-9	V
V _{OH}	Output Swing High	R _L = 500Ω	10	10.3		V
		R _L = 250Ω	9.5	10		V
I _{SC}	Short Circuit Current	R _L = 10Ω	140	180		mA
Power Supply Performance						
PSRR	Power Supply Rejection Ratio	V _S is moved from ±10.8V to ±13.2V	65	83		dB
I _S	Supply Current (Per Amplifier)	No load	4	5	6	mA
Dynamic Performance						
SR	Slew Rate [2]	±2.5V square wave, measured 25%-75%	44	65		V/μs
t _S	Settling to +0.1% (A _V = +1)	(A _V = +1), V _O = 2V step		50		ns
BW	-3dB Bandwidth			80		MHz
HD2	2nd Harmonic Distortion	f = 1MHz, V _O = 2V _{P-P} , R _L = 500Ω, A _V = 2		-86		dBc
		f = 1MHz, V _O = 2V _{P-P} , R _L = 150Ω, A _V = 2		-79		dBc
HD3	3rd Harmonic Distortion	f = 1MHz, V _O = 2V _{P-P} , R _L = 500Ω, A _V = 2		-93		dBc
		f = 1MHz, V _O = 2V _{P-P} , R _L = 150Ω, A _V = 2		-70		dBc

1. Measured over operating temperature range
2. Slew rate is measured on rising and falling edges

EL2228C - Preliminary

Dual Low Noise Amplifier

EL2228C - Preliminary

Electrical Characteristics

$V_{S+} = +5V$, $V_{S-} = -5V$, $R_L = 500\Omega$ and $C_L = 3pF$ to $0V$, $R_F = 420\Omega$ & $T_A = 25^\circ C$ unless otherwise specified.

Parameter	Description	Condition	Min	Typ	Max	Unit
Input Characteristics						
V_{OS}	Input Offset Voltage	$V_{CM} = 0V$		0.6	3	mV
TCV_{OS}	Average Offset Voltage Drift	[1]		4.9		$\mu V/^\circ C$
I_B	Input Bias Current	$V_{CM} = 0V$	-9	-4.5	-1	μA
R_{IN}	Input Impedance			6		$M\Omega$
C_{IN}	Input Capacitance			1.2		pF
CMIR	Common-Mode Input Range		-4.7		+3.4	V
CMRR	Common-Mode Rejection Ratio	for V_{IN} from -4.7V to +3.4V	60	90		dB
		for V_{IN} from -2V to +2V				dB
A_{VOL}	Open-Loop Gain	$-2.5V \leq V_{OUT} \leq 2.5V$	60	72		dB
e_n	Voltage Noise	$f = 100kHz$		4.7		nV/\sqrt{Hz}
i_n	Current Noise	$f = 100kHz$		1.2		pA/\sqrt{Hz}
Output Characteristics						
V_{OL}	Output Swing Low	$R_L = 500\Omega$		-3.8	-3.5	V
		$R_L = 250\Omega$		-3.7	-3.5	V
V_{OH}	Output Swing High	$R_L = 500\Omega$	3.5	3.7		V
		$R_L = 250\Omega$	3.5	3.6		V
I_{SC}	Short Circuit Current	$R_L = 10\Omega$	60	100		mA
Power Supply Performance						
PSRR	Power Supply Rejection Ratio	V_S is moved from $\pm 4.5V$ to $\pm 5.5V$	65	83		dB
I_S	Supply Current (Per Amplifier)	No load	3.5	4.5	5.5	mA
Dynamic Performance						
SR	Slew Rate [2]	$\pm 2.5V$ square wave, measured 25%-75%	35	50		$V/\mu s$
t_s	Settling to +0.1% ($A_V = +1$)	($A_V = +1$), $V_O = 2V$ step		50		ns
BW	-3dB Bandwidth			75		MHz
HD2	2nd Harmonic Distortion	$f = 1MHz$, $V_O = 2V_{P-P}$, $R_L = 500\Omega$, $A_V = 2$		-90		dBc
		$f = 1MHz$, $V_O = 2V_{P-P}$, $R_L = 150\Omega$, $A_V = 2$		-71		dBc
HD3	3rd Harmonic Distortion	$f = 1MHz$, $V_O = 2V_{P-P}$, $R_L = 500\Omega$, $A_V = 2$		-99		dBc
		$f = 1MHz$, $V_O = 2V_{P-P}$, $R_L = 150\Omega$, $A_V = 2$		-69		dBc

1. Measured over operating temperature range
2. Slew rate is measured on rising and falling edges

EL2228C - Preliminary

Dual Low Noise Amplifier

Typical Performance Curves

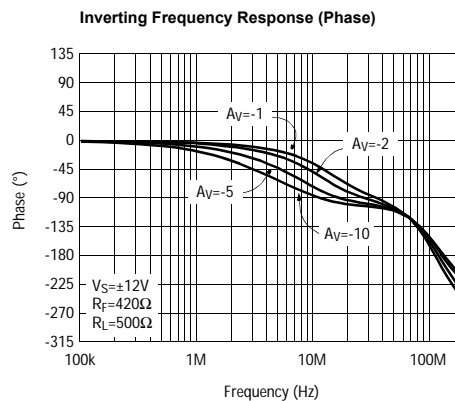
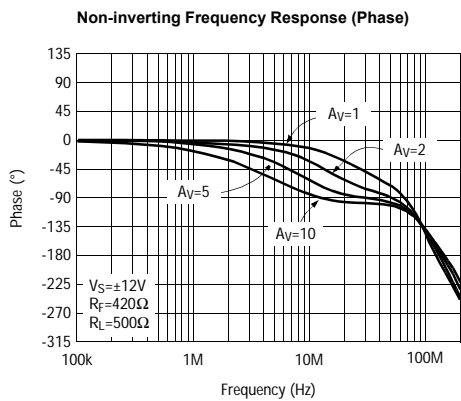
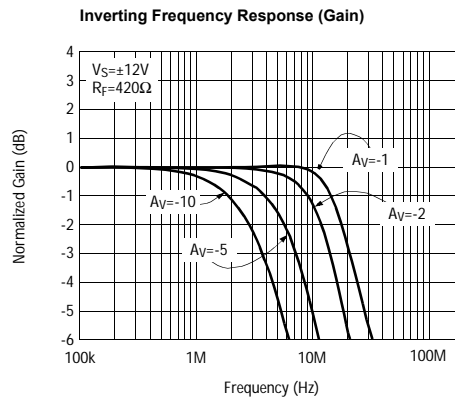
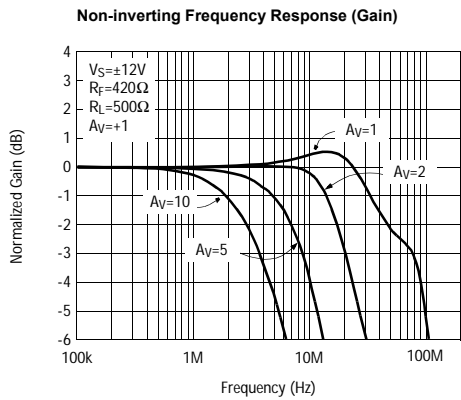
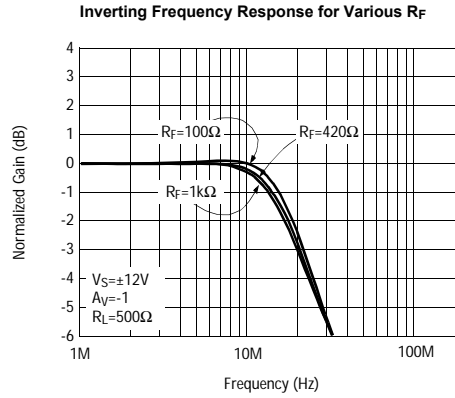
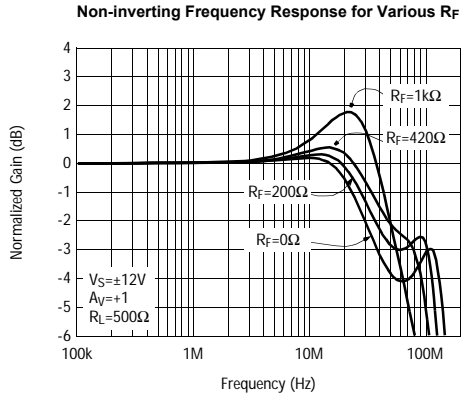

EL2228C - Preliminary

Dual Low Noise Amplifier

EL2228C - Preliminary

Typical Performance Curves

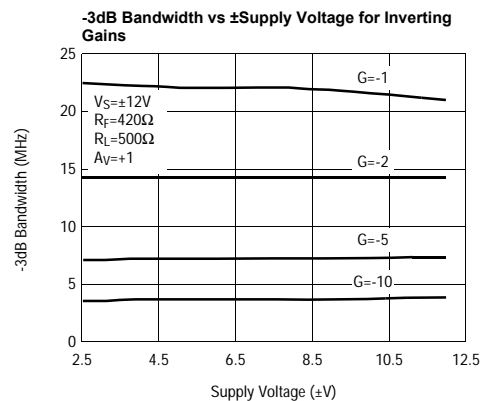
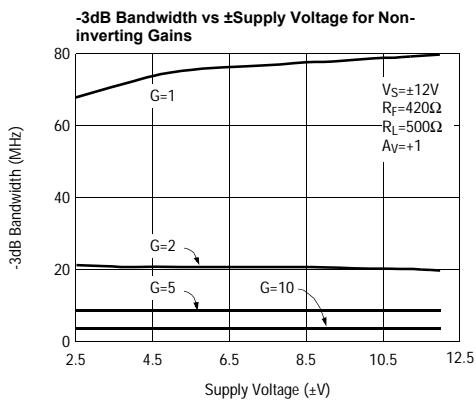
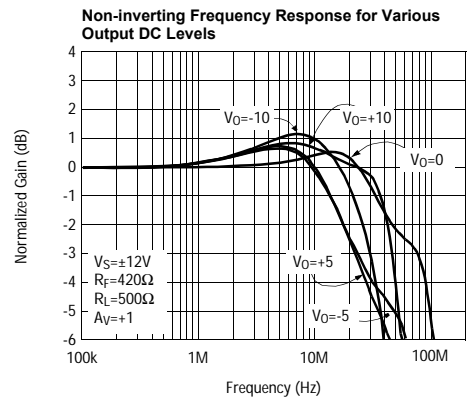
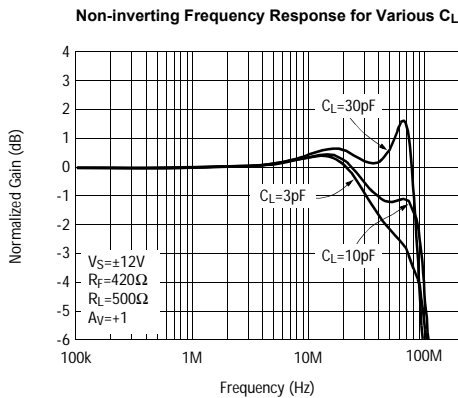
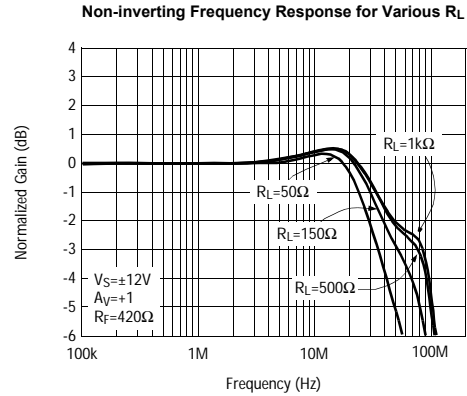
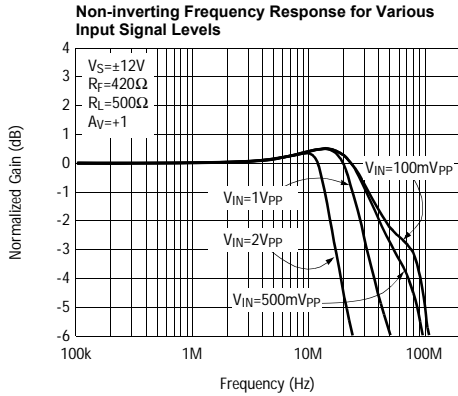

EL2228C - Preliminary

Dual Low Noise Amplifier

Typical Performance Curves

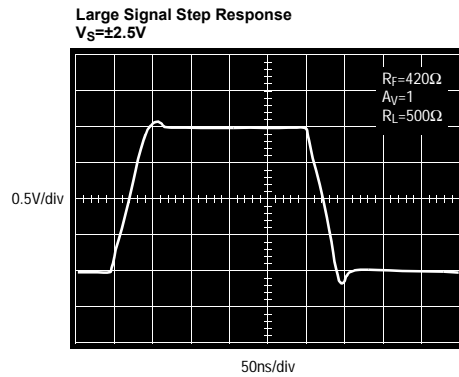
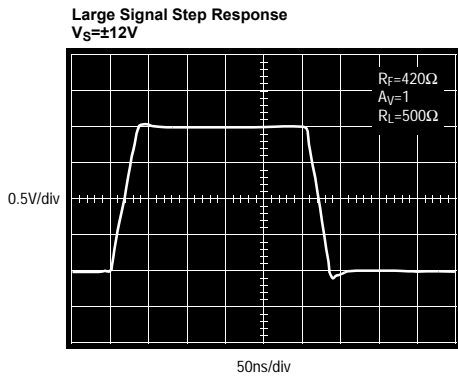
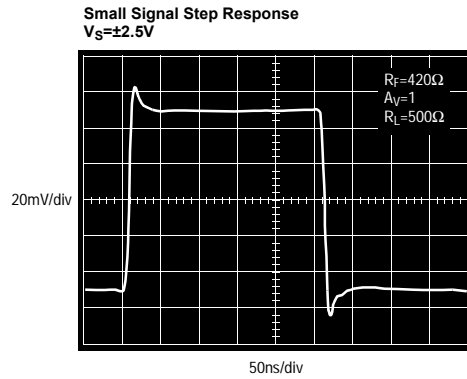
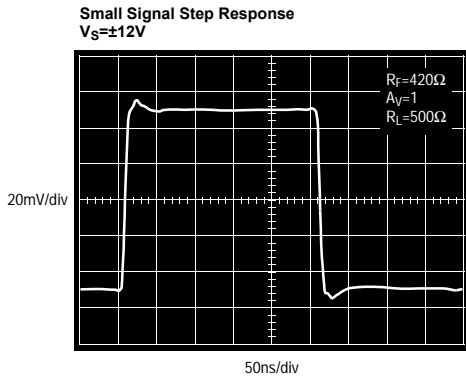
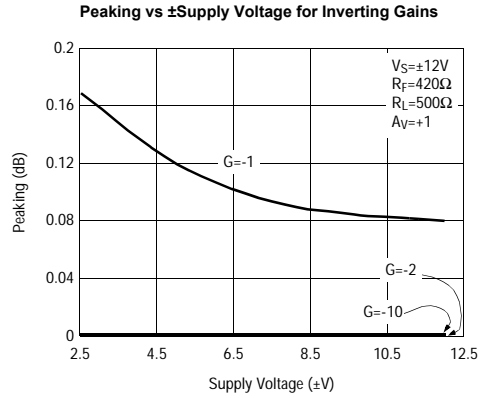
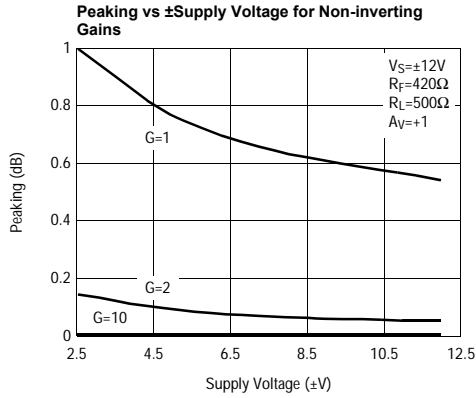

EL2228C - Preliminary

Dual Low Noise Amplifier

EL2228C - Preliminary

Typical Performance Curves

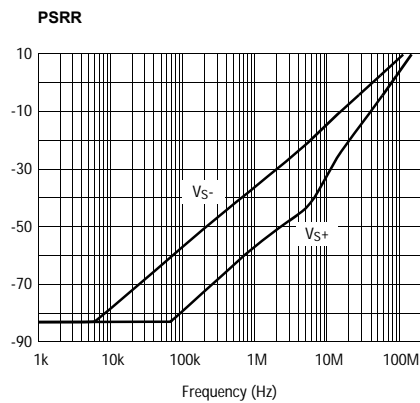
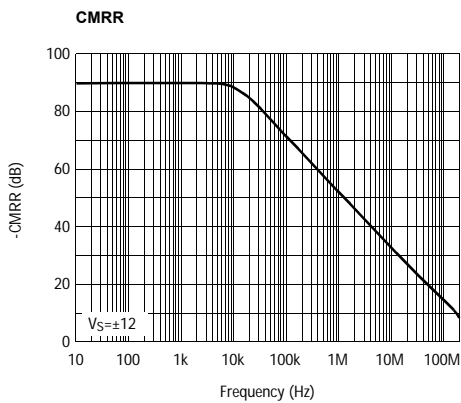
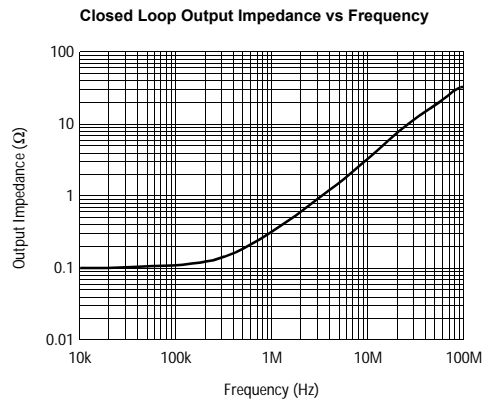
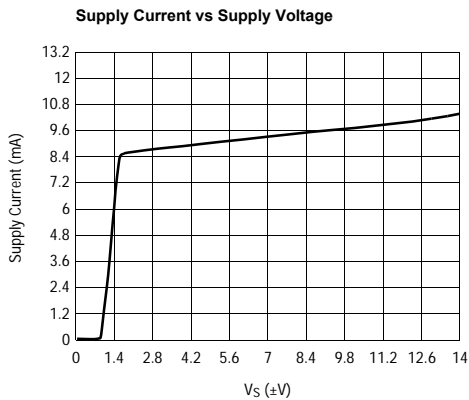
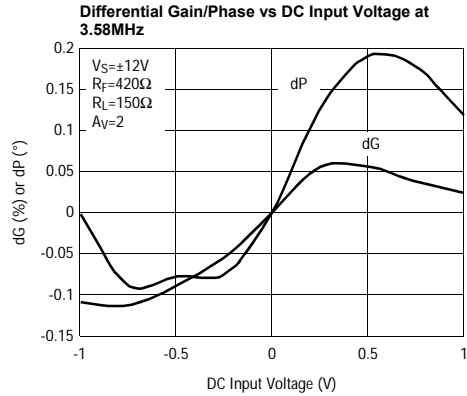
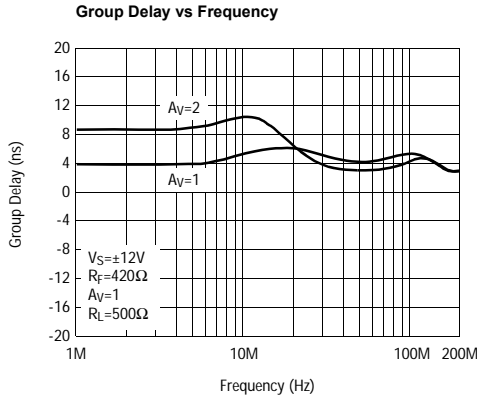

EL2228C - Preliminary

Dual Low Noise Amplifier

Typical Performance Curves

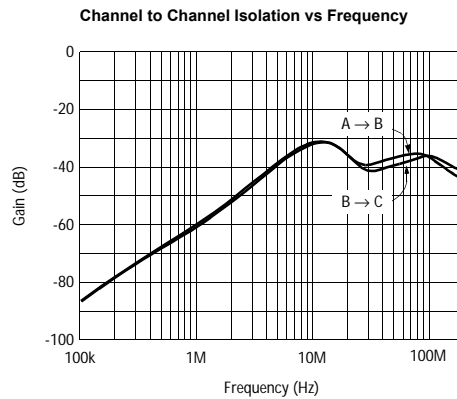
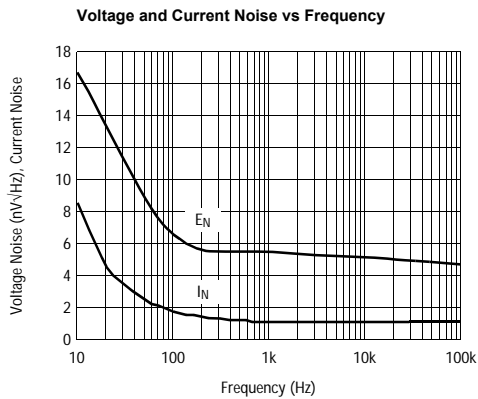
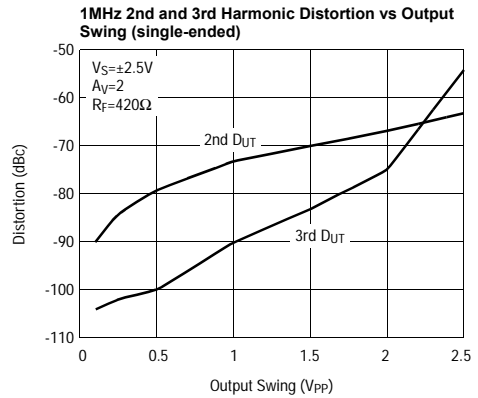
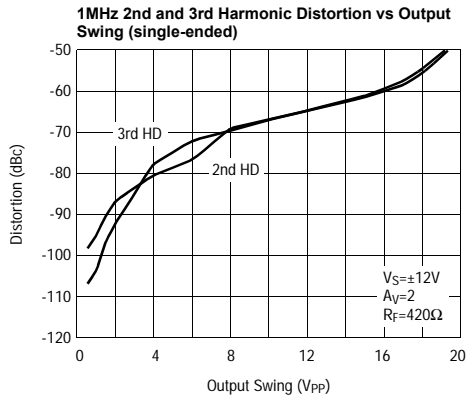
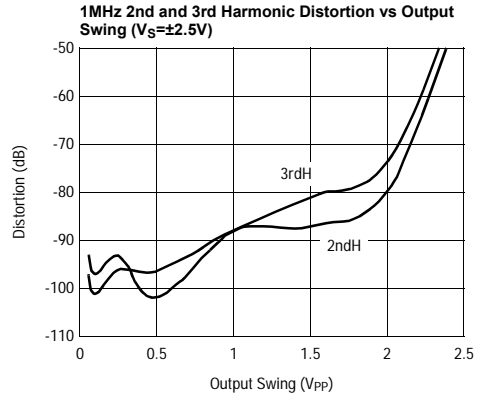
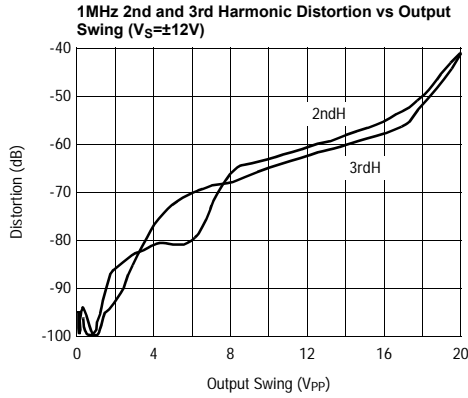

EL2228C - Preliminary

Dual Low Noise Amplifier

EL2228C - Preliminary

Typical Performance Curves

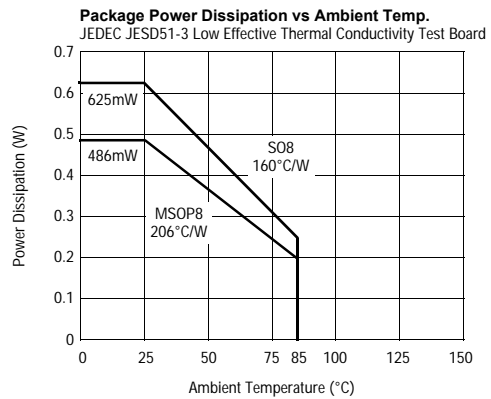
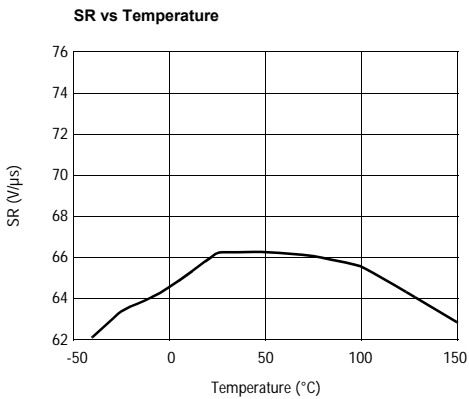
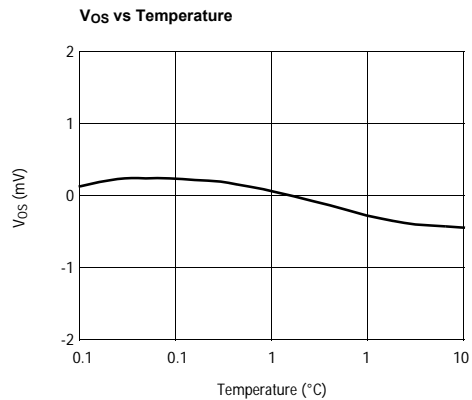
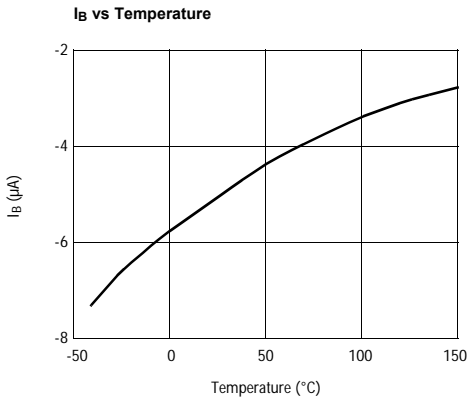
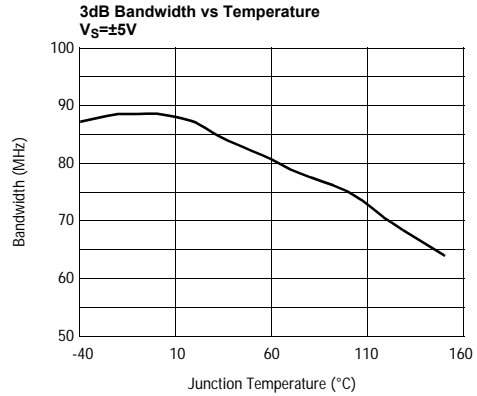
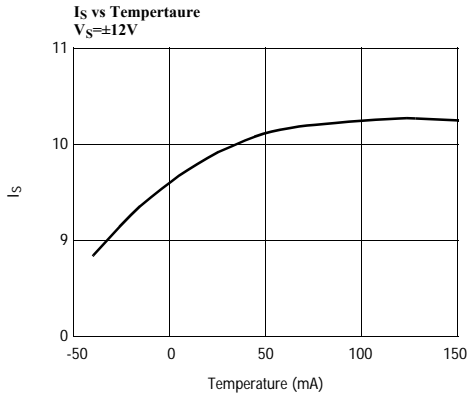

EL2228C - Preliminary
Dual Low Noise Amplifier

Pin Descriptions

EL2228CY 8-Pin MSOP	EL2228CS 8- Pin SO	Pin Name	Pin Function	Equivalent Circuit

EL2228C - Preliminary
Dual Low Noise Amplifier

EL2228C - Preliminary

Applications Information

Product Description

EL2228C - Preliminary**Dual Low Noise Amplifier****General Disclaimer**

Specifications contained in this data sheet are in effect as of the publication date shown. Elantec, Inc. reserves the right to make changes in the circuitry or specifications contained herein at any time without notice. Elantec, Inc. assumes no responsibility for the use of any circuits described herein and makes no representations that they are free from patent infringement.

élantec

HIGH PERFORMANCE ANALOG INTEGRATED CIRCUITS

Elantec Semiconductor, Inc.

675 Trade Zone Blvd.

Milpitas, CA 95035

Telephone: (408) 945-1323

(888) ELANTEC

Fax: (408) 945-9305

European Office: +44-118-977-6020

Japan Technical Center: +81-45-682-5820

WARNING - Life Support Policy

Elantec, Inc. products are not authorized for and should not be used within Life Support Systems without the specific written consent of Elantec, Inc. Life Support systems are equipment intended to support or sustain life and whose failure to perform when properly used in accordance with instructions provided can be reasonably expected to result in significant personal injury or death. Users contemplating application of Elantec, Inc. Products in Life Support Systems are requested to contact Elantec, Inc. factory headquarters to establish suitable terms & conditions for these applications. Elantec, Inc.'s warranty is limited to replacement of defective components and does not cover injury to persons or property or other consequential damages.