

AN7199Z

Dual 20 W BTL power IC for car audio

■ Overview

The AN7199Z is an audio power IC developed for the sound output of car audio (dual 20 W).

A capacitor and a resistor to stop oscillation are built in between the output pin and GND so that a space saving of set is possible. Also, it incorporates an industry's first superior muting circuit which is free from shock noise, so that a shock noise design under the set transient condition can be made easily when the muting circuit is used together with its standby function.

In addition, it is incorporating various protective circuits to protect the IC from destruction by GND-open short-circuit to GND and power supply surge which are the most important subjects of power IC protection, and the IC will largely contribute to a high reliability design of equipment.

■ Features

- Built-in various protection circuits (realizing high breakdown voltage against destruction)
 - Power supply surge breakdown voltage of 80 V or more
 - Ground open breakdown voltage of 16 V or more
- Built-in standby function (free from shock noise when STB-on/off)
- Built-in muting function
 - Free from shock noise at mute-on/off
- Adapting attenuator method so that abnormal sound due to waveform deformation is not generated
 - Attack time, recovery time of 50 ms or less
- Reduction in external components
 - No CR for oscillation stop is required
 - It eliminates the need for NF and BS electrolytic capacitors
 - Muting function is unnecessary
 - Power supply choke coil is unnecessary
- Provided with beep sound input pin
- High sound quality design

■ Applications

- Car audio

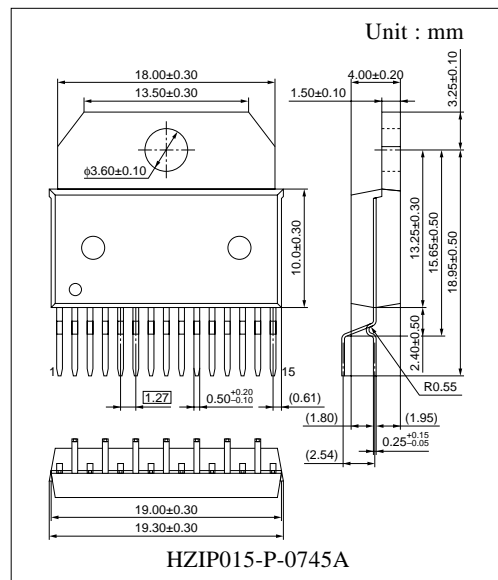

■ Block Diagram

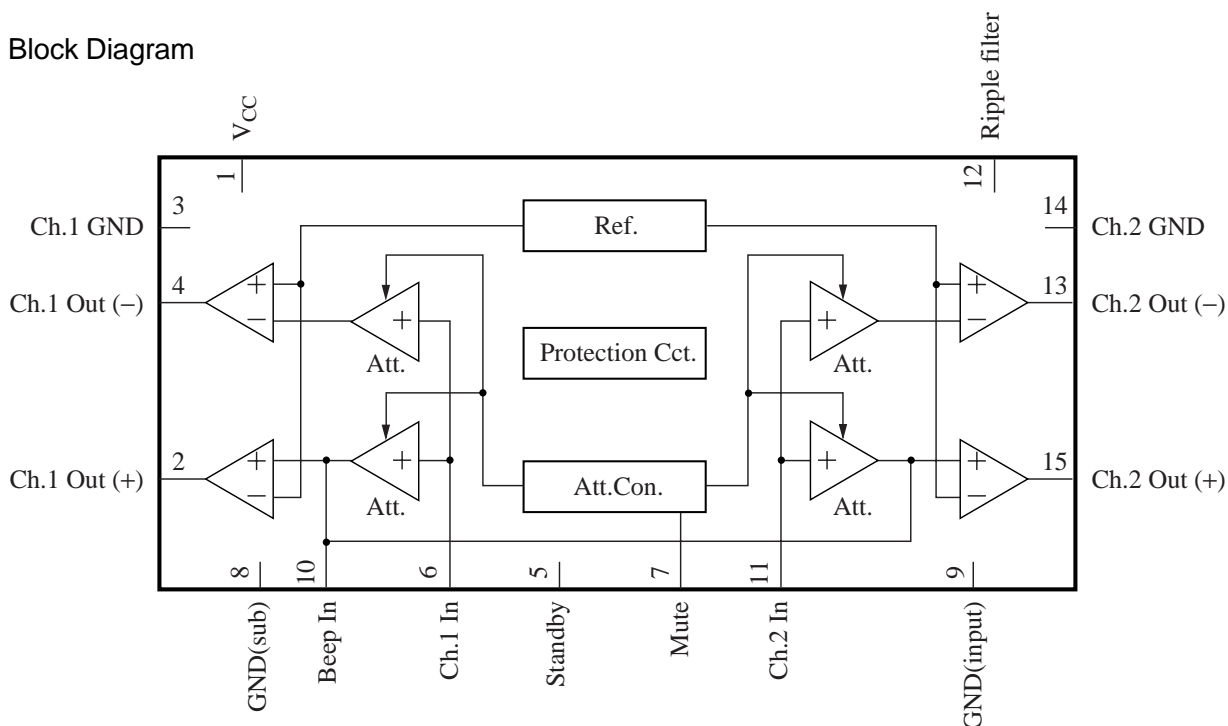

■ Pin Descriptions

Pin No.	Description	Pin No.	Description
1	Power supply	9	Grounding (input)
2	Ch.1 output (+)	10	Beep sound input
3	Grounding (output ch.1)	11	Ch.2 input
4	Ch.1 output (-)	12	Ripple filter
5	Standby	13	Ch.2 output (-)
6	Ch.1 input	14	Grounding (output ch.2)
7	Muting	15	Ch.2 output (+)
8	Grounding (sub)		

■ Absolute Maximum Ratings

Parameter	Symbol	Rating	Unit
Supply voltage ^{*2}	V_{CC}	25	V
Peak supply voltage ^{*3}	V_{surge}	60	V
Supply current	I_{CC}	9.0	A
Power dissipation ^{*4}	P_D	59	W
Operating ambient temperature ^{*1}	T_{opr}	-30 to +85	°C
Storage temperature ^{*1}	T_{stg}	-55 to +150	°C

Note) *1 : All items are at $T_a = 25^\circ\text{C}$, except for the operating ambient temperature and storage temperature.

*2 : Without signal

*3 : Time = 0.2 s

*4 : $T_a = 85^\circ\text{C}$

■ Recommended Operating Range

Parameter	Symbol	Range	Unit
Supply voltage	V_{CC}	8.0 to 18.0	V

■ Electrical Characteristics at $V_{CC} = 13.2\text{ V}$, $f = 1\text{ kHz}$, $T_a = 25^\circ\text{C}$

Parameter	Symbol	Conditions	Min	Typ	Max	Unit
Quiescent current	I_{CQ}	$V_{IN} = 0\text{ mV}$, $R_L = 4\ \Omega$	—	120	250	mA
Standby current	I_{STB}	$V_{IN} = 0\text{ mV}$, $R_L = 4\ \Omega$	—	1	10	μA
Output noise voltage *1	V_{NO}	$R_g = 10\text{ k}\Omega$, $R_L = 4\ \Omega$	—	0.18	0.5	mV[rms]
Voltage gain 1	G_{V1}	$V_{IN} = 20\text{ mV}$, $R_L = 4\ \Omega$	38	40	42	dB
Total harmonic distortion 1	THD_1	$V_{IN} = 20\text{ mV}$, $R_L = 4\ \Omega$	—	0.07	0.4	%
Maximum output power 1	P_{O1}	$THD = 10\%$, $R_L = 4\ \Omega$	16	18.5	—	W
		$V_{CC} = 14.4\text{ V}$, $R_L = 4\ \Omega$	—	22.0	—	W
Ripple rejection ratio *1	RR	$R_L = 4\ \Omega$, $R_g = 10\text{ k}\Omega$, $V_r = 1\text{ V[rms]}$, $f_r = 1\text{ kHz}$	55	60	—	dB
Channel balance	CB	$V_{IN} = 20\text{ mV}$, $R_L = 4\ \Omega$	—	0	1	dB
Cross-talk *1	CT	$V_{IN} = 20\text{ mV}$, $R_L = 4\ \Omega$, $R_g = 10\text{ k}\Omega$	60	79	—	dB
Output offset voltage	V_{Off}	$R_g = 10\text{ k}\Omega$, $R_L = 4\ \Omega$	-300	0	300	mV
Muting effect *1	MT	$V_O = 1\text{ W}$, $R_L = 4\ \Omega$	70	86	—	dB
Input impedance	Z_i	$V_{IN} = \pm 0.3\text{ V}_{DC}$	24	30	36	k Ω
Voltage gain 2	G_{V2}	$V_{IN} = 20\text{ mV}$, $R_L = 2\ \Omega$	38	40	42	dB
Total harmonic distortion 2	THD_2	$V_{IN} = 20\text{ mV}$, $R_L = 2\ \Omega$	—	0.12	0.5	%
Maximum output power 2	P_{O2}	$THD = 10\%$, $R_L = 2\ \Omega$	16	25	—	W
Shock noise *2	V_S	$R_L = 4\ \Omega$, $R_g = 10\text{ k}\Omega$ $V_{STB} = \text{on/off}$, 50 Hz HPF-on	-100	0	100	mV[p-0]
Total harmonic distortion 3	THD_3	$V_{IN} = 10\text{ mV}$, $f_{IN} = 20\text{ kHz}$ $R_g = 10\text{ k}\Omega$, $R_L = \infty$	—	0.10	0.5	%

Note) *1 : Measurement using a bandwidth 15 Hz to 30 kHz (12 dB/OCT) filter.

*2 : For $V_{STB} = \text{on/off}$, change over the standby terminal by the voltages of 0 V and 5 V at the time shown below.

Standby terminal voltage

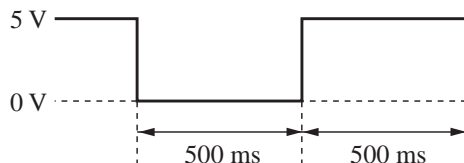

■ Terminal Equivalent Circuits

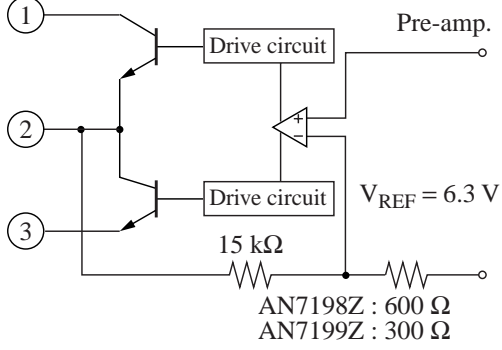
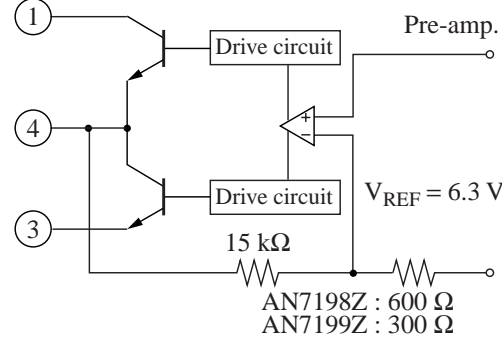
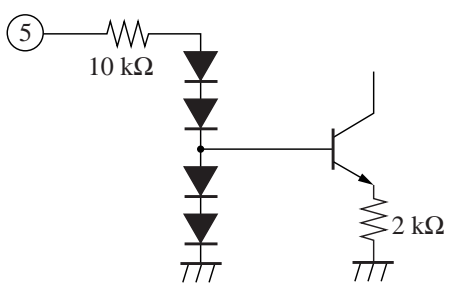
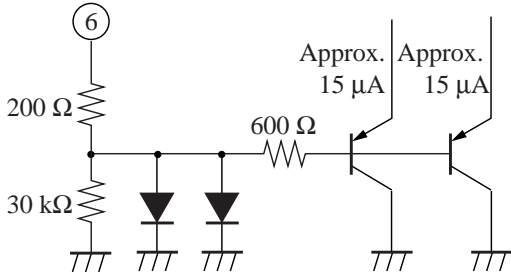
Pin No.	Equivalent circuit	Description	DC Voltage
1	—	Supply voltage pin Supply connection pin	13.2 V
2		Ch.1 output pin (+) Ch.1 positive-phase output pin	6.6 V
3	—	GND (output) Grounding pin for ch.1 output	0 V
4		Ch.1 output pin (-) Ch.1 inverted-phase output pin	6.6 V
5		Standby control pin Standby changeover pin Threshold voltage approx. 2.1 V	—
6		Ch.1 input pin Ch.1 input signal applied pin Input impedance 30 kΩ	0 mV to 10 mV

■ Terminal Equivalent Circuits (continued)

Pin No.	Equivalent circuit	Description	DC Voltage
7		Mute control pin Mute changeover pin Threshold voltage approx. 2.1 V	—
8	—	GND (substrate) Being connected with substrate only	0 V
9	—	GND (input) Ground pin for input	0 V
10	<p> R_{nf} AN7198Z : 600Ω R_{nf} AN7199Z : 300Ω </p>	Beep sound input pin Beep sound signal input pin Input impedance 15.3 kΩ	2.1 V
11		Ch.2 input pin Ch. 2 input signal applied pin Input impedance 30 kΩ	0 mV to 10 mV
12		Ripple filter pin Output current 3 mA to 10 mA	13.0 V

■ Terminal Equivalent Circuits (continued)

Pin No.	Equivalent circuit	Description	DC Voltage
13		Ch.2 output pin (-) Ch.2 inverted-phase output pin	6.3 V
14	—	GND(output) Grounding pin for ch.2 output	0 V
15		Ch.2 output pin (+) Ch.2 positive-phase output pin	6.3 V

■ Usage Notes

1. Always attach an outside heat sink to use the chip. In addition, the outside heat sink must be fastened onto a chassis for use.
2. Connect the cooling fin to GND potential.
3. Avoid short-circuit to V_{CC} and short-circuit to GND, and load short-circuit. There is a danger of destruction under a special condition.
4. The temperature protection circuit will be actuated at $T_j = \text{approx. } 150^\circ\text{C}$, but it is automatically reset when the chip temperature drops below the above set level.
5. The overvoltage protection circuit starts its operation at $V_{CC} = \text{approx. } 20 \text{ V}$.
6. Take into consideration the heat radiation design particularly when V_{CC} is set high or when the load is 2Ω .
7. When the beep sound function is not used, open the beep sound input pin (pin 10) or connect it to pin 9 with around $0.01 \mu\text{F}$ capacitor.
8. Connect only pin 9 (ground, signal source) to the signal GND of the amplifier in the previous stage. The characteristics such as distortion, etc. will be improved.

■ Technical Information

[1] $P_D - T_a$ curves of HZIP015-P-0745A

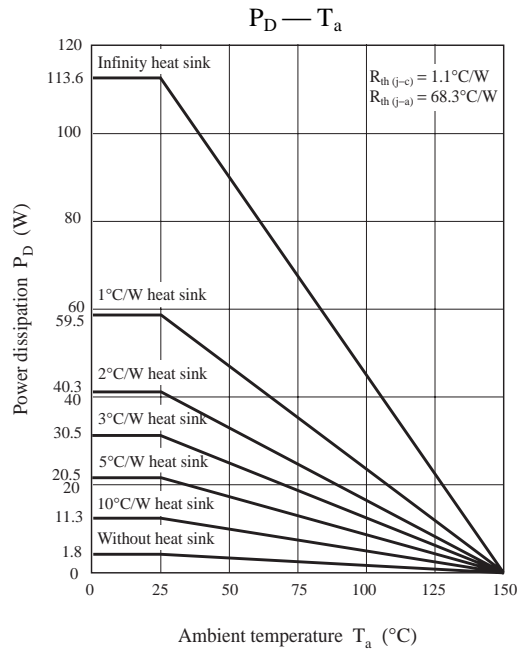

[2] Main characteristics

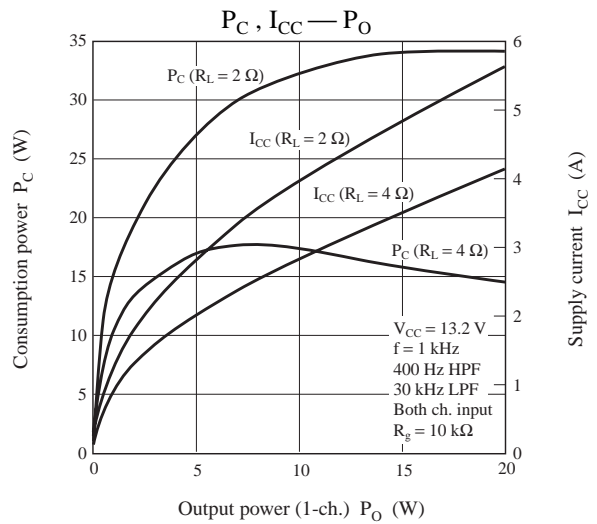
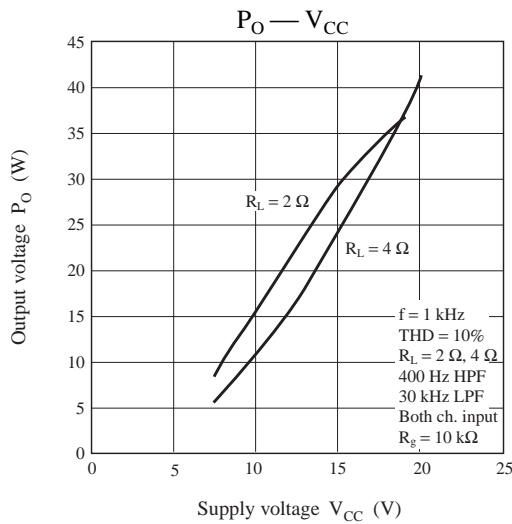

■ Technical Information (continued)

[2] Main characteristics (continued)

P_O , THD — V_{IN} ($R_L = 4 \Omega$)

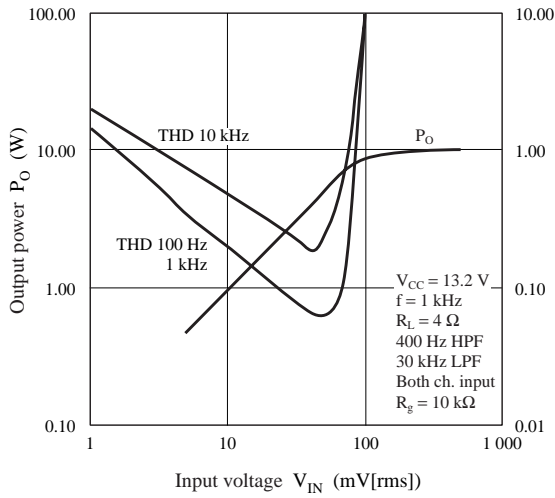

P_O , THD — V_{IN} ($R_L = 2 \Omega$)

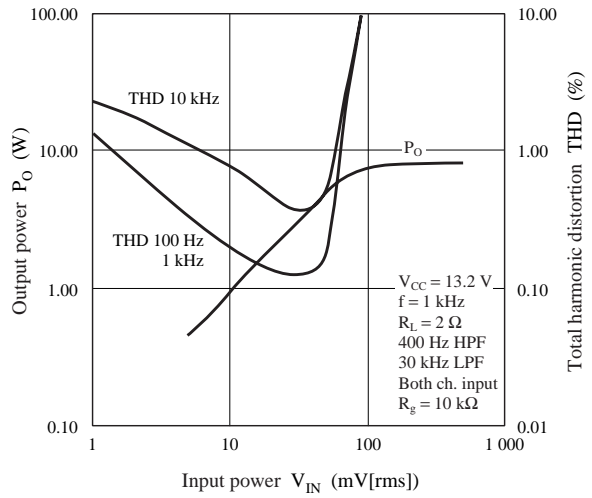

G_V , P_O — f

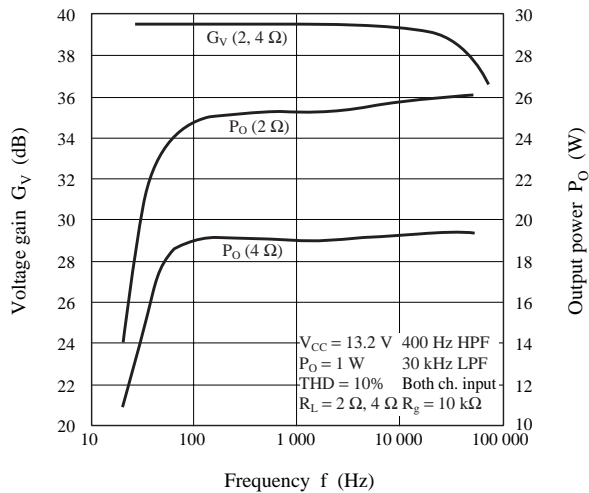

THD — f

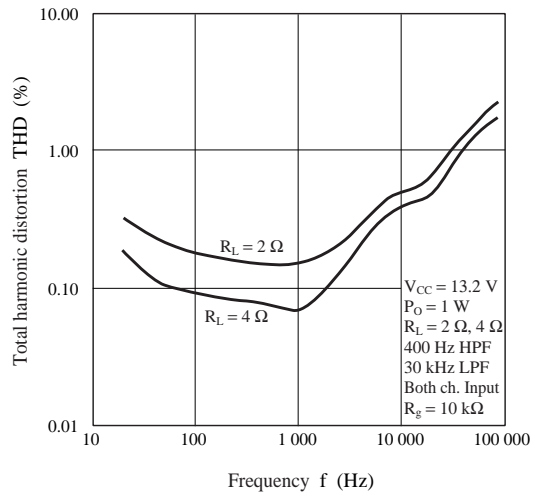

G_V , THD — V_{CC}

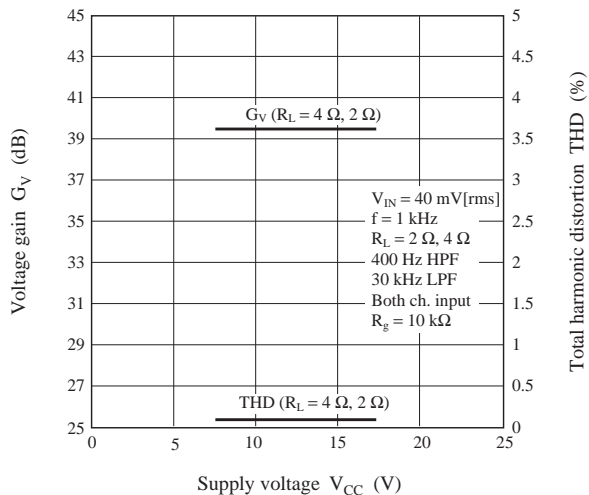

I_{CQ} , I_{STB} — V_{CC}

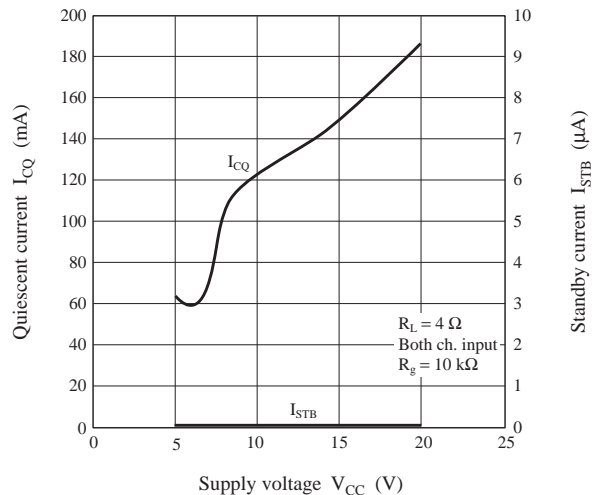

■ Technical Information (continued)

[2] Main characteristics (continued)

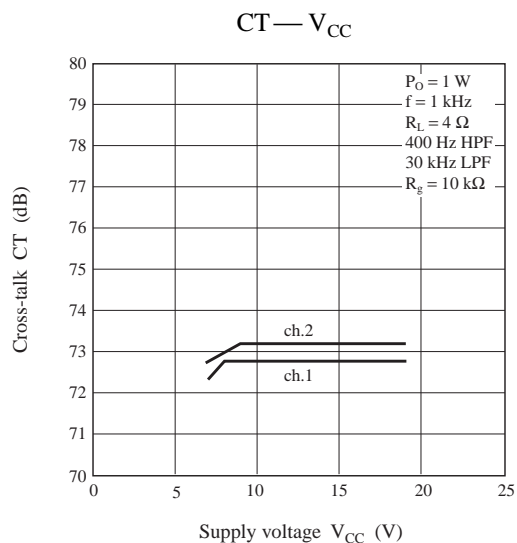
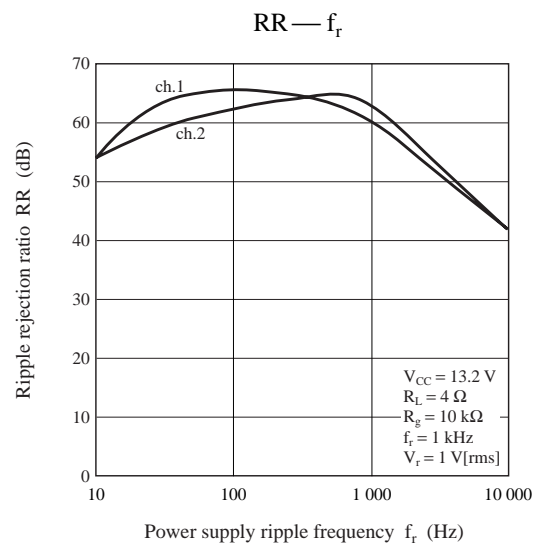
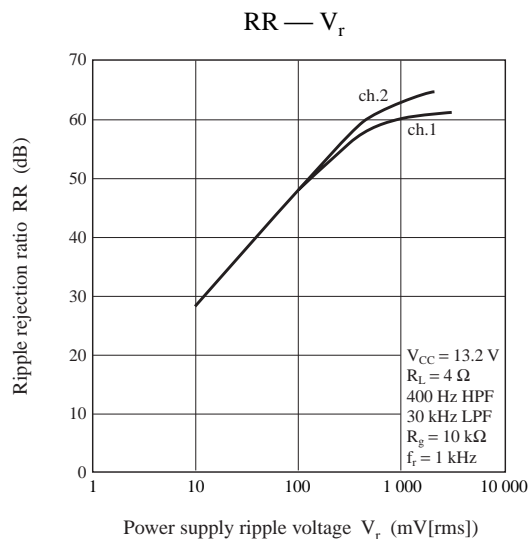
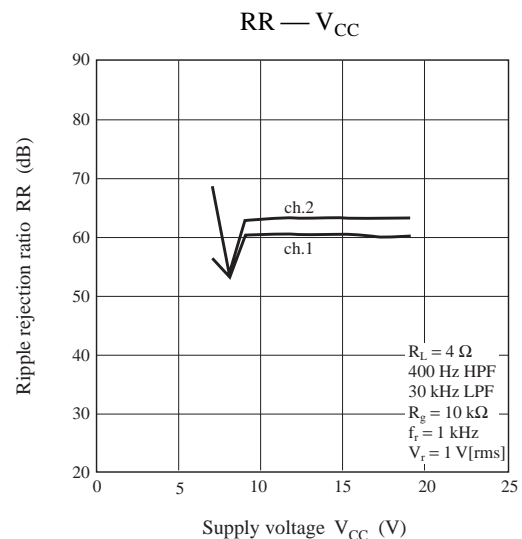
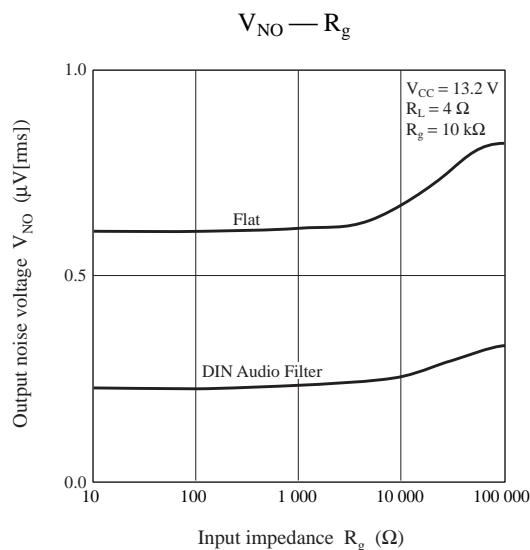
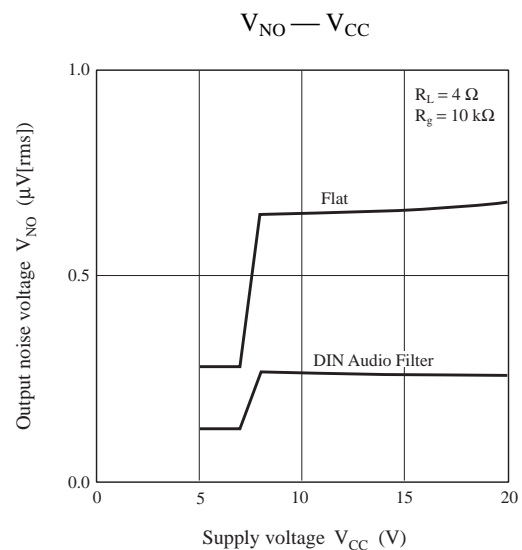

■ Technical Information (continued)

[2] Main characteristics (continued)

CT — V_{IN}

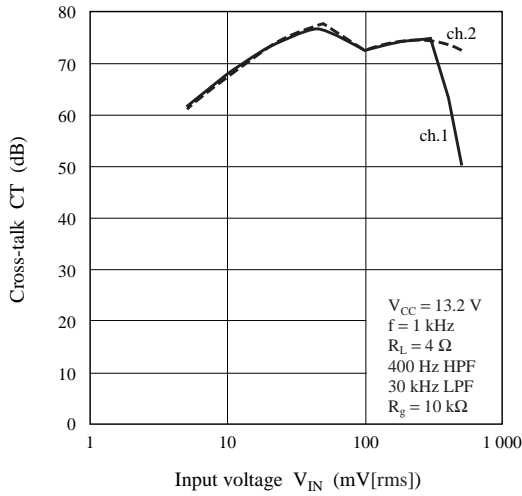

CT — f

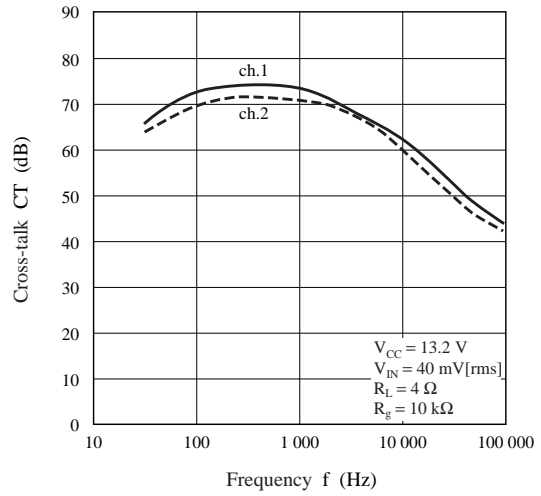

MT — V_{CC}

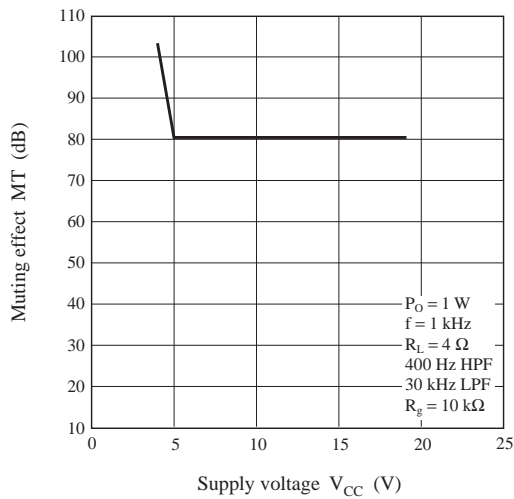

MT — V_{IN}

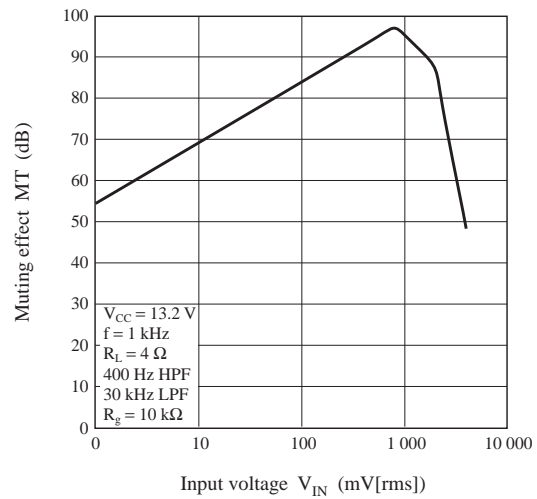

MT — f

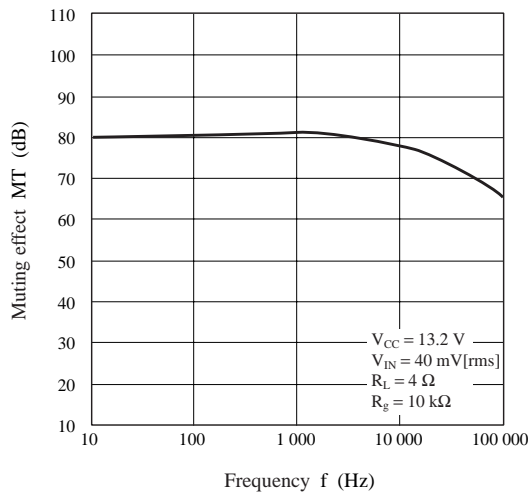

MT — V_{MUTE}

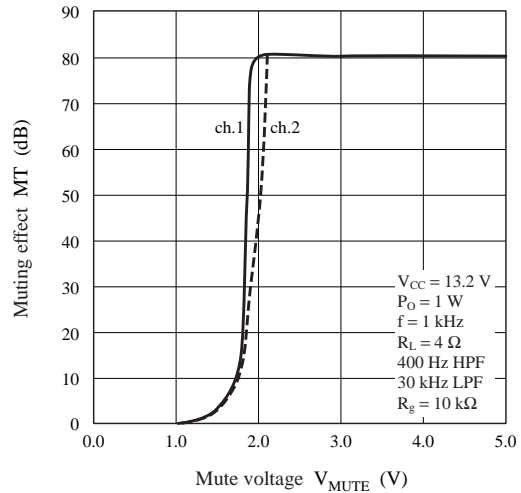

■ Technical Information (continued)

[2] Main characteristics (continued)

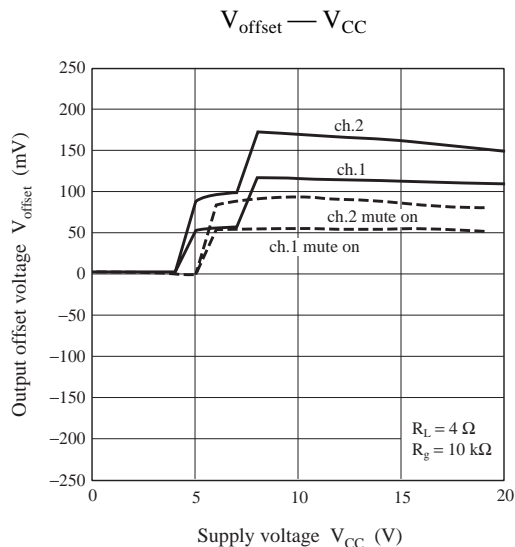
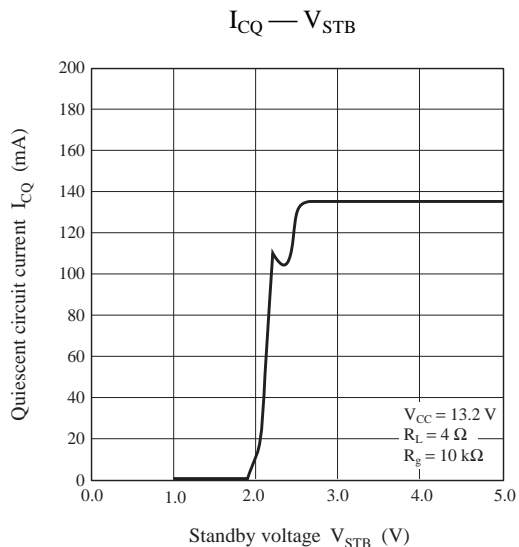

[3] Application note

1. Standby function

- 1) The power can be turned on or off by making pin 5 (standby terminal) high or low.
- 2) The standby terminal has threshold voltage of approx. 2.1 V, however, it has temperature dependency of approx. $-6 \text{ mV}/^\circ\text{C}$. The recommended range of use is shown in table 1.

Table 1

Terminal state	Terminal voltage	Power
Open	0 V	Standby state
Low	0 V to 1.0 V	Standby state
High	Higher than 3 V	Operating state

- 3) The internal circuit of standby terminal is as shown in figure 1. When the standby terminal is high, the current approximately expressed by the following equation will flow into the circuit.

$$I_{STB} = \frac{V_{STB} - 2.7 \text{ V}}{10 \text{ k}\Omega} \text{ [mA]}$$

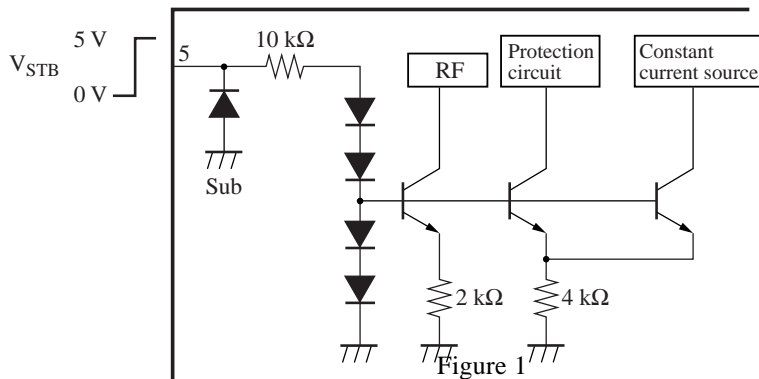

- 4) A power supply with no ripple component should be used for the control voltage of standby terminal .

■ Technical Information (continued)

[2] Application note (continued)

2. Oscillation countermeasures

- 1) In order to increase the oscillation allowance, it is unnecessary to use a capacitor and a resistor between each output terminal and GND. However, when inserting the capacitor for counter-measures against output line noise between the output terminal and GND, insert a resistor of approx. 2.2 Ω in series as shown in figure 2. The oscillation may occur if only capacitor is used. Use it after giving a sufficient evaluation
- 2) The use of polyester film capacitor having a little fluctuation with temperature and frequency is recommended as the capacitor for counter-measures against output line noise.

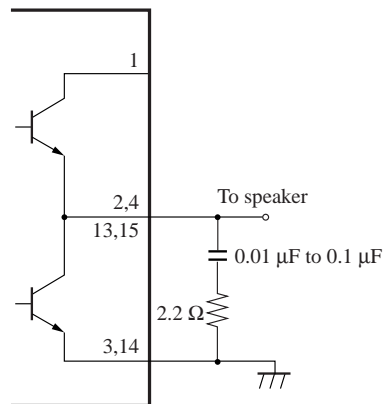

Figure 2

3. Input terminal

- 1) The reference voltage of input terminal is 0 V. When the input signal has a reference voltage other than 0 V potential, connect a coupling capacitor (of about several μF) for DC component cut in series with the input terminal. Check the low-pass frequency characteristics to determine the capacitor value.
- 2) 10 kΩ or less of signal source impedance R_g can reduce the output end noise voltage.
- 3) The output offset voltage fluctuates when the signal source impedance R_g is changed. A care must be taken when using the circuit by directly connecting the volume to the input terminal. In such a case, the use of coupling capacitor is recommended.
- 4) If a high frequency signal from tuners enters the input terminal as noise, insert a capacitor of approx. 0.01 μF between the input terminal and input GND.

When a high frequency signal is inputted, malfunction in protective circuits may occur.

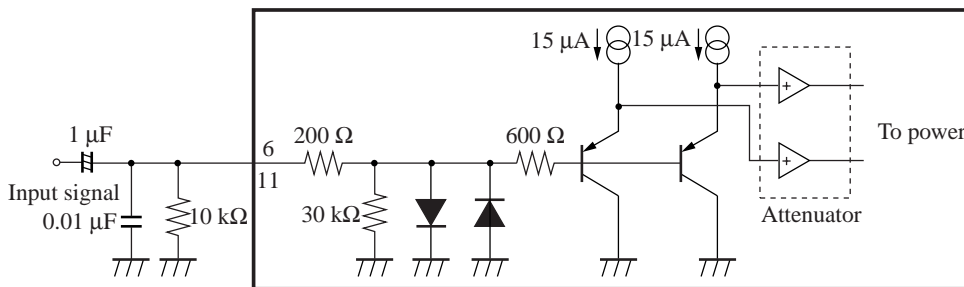

Figure 3

4. Ripple filter

- 1) In order to suppress the fluctuation of supply voltage, connect a capacitor of approx. 33 μF between RF terminal (pin12) and GND.
- 2) Relation between RR (Ripple Rejection Ratio) and a capacitor
The larger the capacitance of the ripple filter is, the better the ripple rejection becomes.
- 3) Relation between the rise time of circuit and a capacitor
The larger the capacitance of the ripple filter is, the longer the time from the power on (standby high) to the sound release becomes.
- 4) The DC voltage of output terminal is approximately the middle point of the ripple filter terminal voltage.
- 5) The internal circuit of ripple filter terminal is as shown in figure 5 and the charge current is approx. 3 mA to 10 mA.

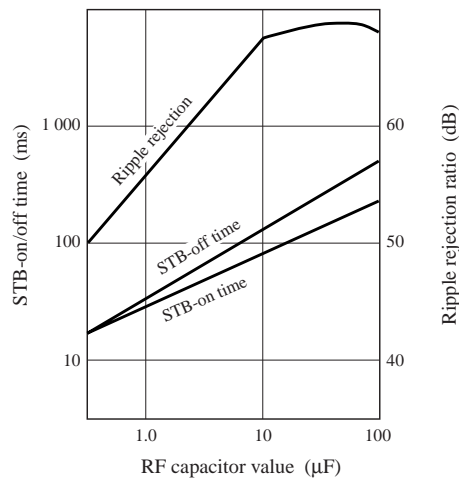

Figure 4

■ Technical Information (continued)

[2] Application note (continued)

4. Ripple filter (continued)

- 6) After the power supply is turned off (STB-low), it takes less than 10 seconds for the total circuit current to become the standby current (under 10 μ A). If approx. 47 ohms resistor is inserted between the ripple filter terminal and GND for the purpose of reducing the inspection time with set, a time until the current becomes the standby current can be shortened.

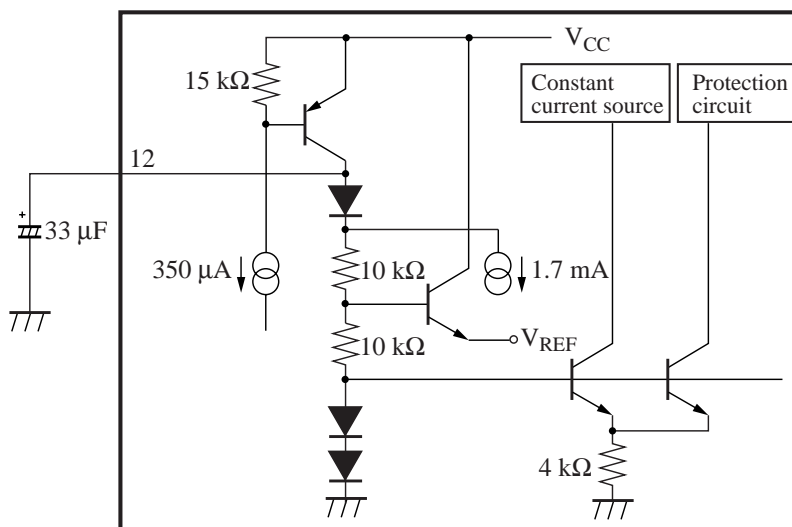

Figure 5

5. GND terminal

- 1) Be sure to short-circuit each GND terminal of pin 3, 8, 9 and 14 at the outside of the IC in use.
- 2) For each GND terminal, the one-point earth, referenced to the GND connection point of electrolytic capacitor between the supply terminal and GND, is most effective for reducing the distortion. Even in the worst case, ground pin 8, 9 of input GND separately from all the other GND terminals.

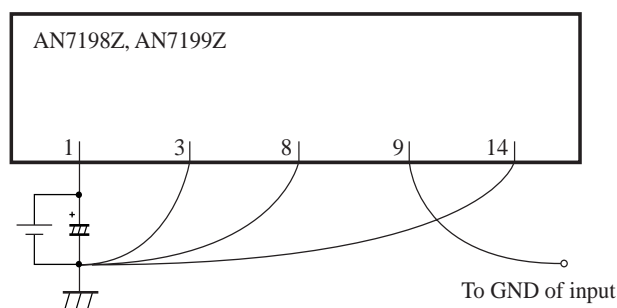

Figure 6

- 3) Each GND terminal is not electrically short-circuited inside. Only pin 8 is connected with substrate.
- 4) Pin 9 is input signal GND. Connect only pin 9 with Pre-GND.

6. Cooling fin

- 1) The cooling fin is not connected with GND terminal by using Au wire. Only pin 8 is electrically connected through substrate.
- 2) Always attach an outside heat sink to the cooling fin. The cooling fin must be fastened onto a chassis for use. Otherwise, IC lead failure may occur.
- 3) Do not give the cooling fin any potential other than the GND potential. Otherwise, it may cause breakdown.
- 4) Connection of the cooling fin with GND can reduce the incoming noise hum. (It is unnecessary to connect with GND in use, but connect with the power GND when the cooling fin is connected with GND)

7. Shock noise

1) STB on/off

No shock noise is released. However, the changeover switch of the standby terminal may make a slight shock noise. In such a case, insert a capacitor of approx. 0.01 μ F between the standby terminal and GND.

2) Mute on/off

No shock noise is released. Refer to the section on the mute function.

■ Technical Information (continued)

[2] Application note (continued)

8. Mute Function

- 1) The mute-on/off is possible by making pin 7 (the muting terminal) high or low.
- 2) The muting circuit is as shown in figure 7. The amplifier gain including attenuator block is given in the following equation :

$$G_V = \frac{I_1}{I_2} \times 50$$

↙ Original gain

From the above equation, the amplifier gain can be made as 0 time by setting I_1 at 0 mA at muting.

- 3) The threshold voltage of V_{MUTE} is as follows :

Mute-off : approx. 1 V or less

Mute-on : approx. 3 V or more

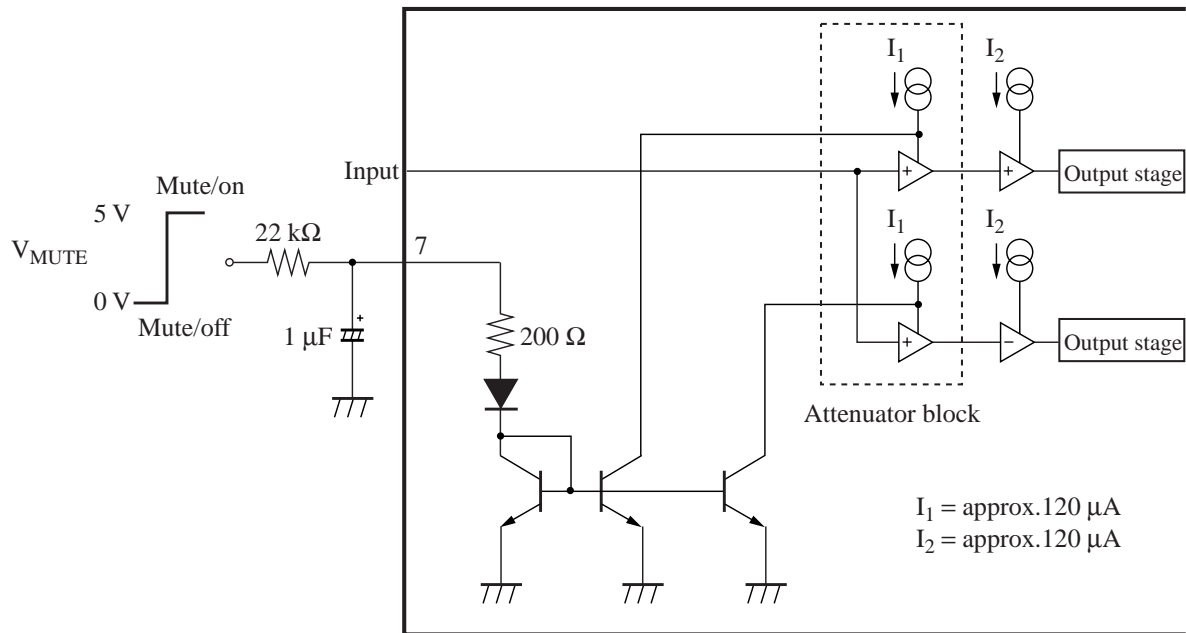

Figure 7

- 4) Attack time and recovery time can be changed by the external CR of pin 7. For recommended circuits (In figure 7 22 kΩ, 1 μF), the above mentioned times are as follows :

Attack time : Approx. 30 ms

Recovery time : Approx. 40 ms

However, the control voltage of V_{MUTE} is assumed to be 5 V. When it is not directly controlled by microcomputer (5 V), (that is, 13.2 V separate power supply), it is necessary to change CR values because the above times change.

- 5) When the attack time and recovery time are set at 20 ms or less, pay attention to the IC with larger output offset because it may release the shock noise.

9. Voltage gain

The voltage gain is fixed at 34 dB for the AN7198Z, and 40 dB for the AN7199Z. It is not possible to change those values by the addition of an external resistor.

■ Technical Information (continued)

[2] Application note (continued)

10. Beep sound input function

- 1) The application circuit using the beep sound input is shown in figure 8. Connect the beep signals from the microcomputer to pin 10 via the capacitor C1 for DC cut and the resistor R1 for voltage gain adjustment.
- 2) The voltage gain of beep sound terminal is approx. -6.2 dB. In the setting value of figure 8, it becomes approx. -19.7 dB (f = 1 kHz).
- 3) The beep sound is outputted to the output, terminals pin 2 and pin 15.

	R _{nf}	G _{VA}
AN7198Z	600 Ω	28 dB
AN7199Z	300 Ω	34 dB

$$G_{VBEEP} = \frac{\frac{R_{nf}}{2}}{1/j\omega C1 + R1 + 7.8 K + \frac{15 k + R_{nf}}{2}} \times G_{VA}$$

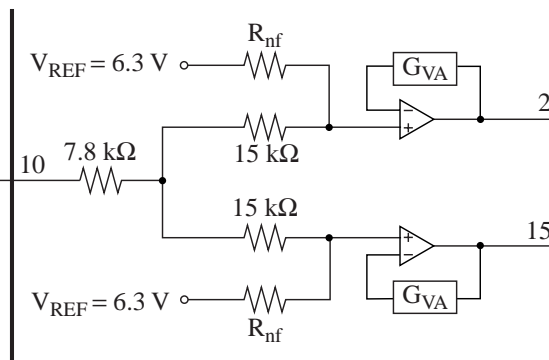

Figure 8

11. Two IC use

Figure 9 shows the application circuit example when two ICs are used :

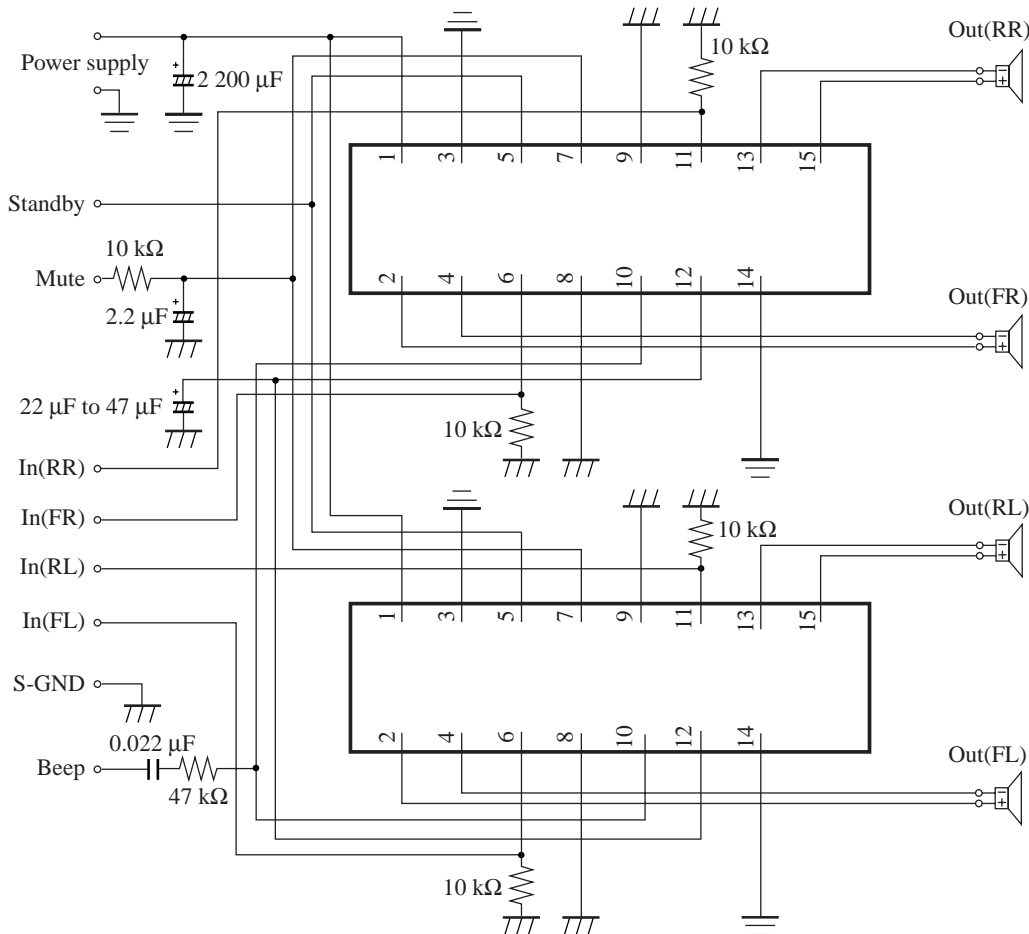

Figure 9

■ Technical Information (continued)

[2] Application note (continued)

11. Two IC use (continued)

1) Supply terminal

Short-circuiting each other, insert an electrolytic capacitor of approx. 2 200 μF into the supply terminals. However, if sufficient characteristics of the ripple rejection can not be obtained, use an even larger capacitor or insert a 2 200 μF capacitor into each IC.

The best sound quality can be obtained by inserting a 2 200 μF capacitor near the terminal of each IC.

2) Standby terminal (pin 5)

Even if the standby terminals are connected with each other, that does not result in an abnormal operation. Connect with the microcomputer after connecting the standby pins with each other. At that time, the current flowing into the standby terminal is twice as large as the current which is described in 1. Standby function.

3) Muting terminal (pin 7)

An abnormal operation does not occur even if the muting terminals are short-circuited with each other.

The muting time constant changes when two ICs connection is made. If the CR constants are set at twice and 1/2 time respectively, the time constant value becomes as same as the value when one IC is used.

In terms of safety design, taking advantage of the fact that a large current is difficult to flow when the mute is being applied so that it is difficult to cause the destruction, it is designed so that the mute terminal will become High when an abnormality such as the short-circuit to V_{CC} or short-circuit to GND takes place. (To avoid the influence of IC in an abnormal state when using two ICs).

Do not connect a microcomputer directly to the mute terminal because the mute terminal voltage rises to approx. 12 V at that time.

4) Beep sound input terminal (pin 10)

Even if the the beep sound input terminals are short-circuited each other, that does not result in an abnormal operation.

However, if there is a temperature difference between ICs, there may be a fluctuation of the output offset. In order to avoid such a phenomenon, connect the ICs with each other through a resistor (47 k Ω).

5) Ripple filter terminal (pin 12)

Even if the ripple filter terminals are short-circuited each other, that does not result in an abnormal operation.

However, if the standby of each IC is individually controlled, the short-circuiting is not allowed. Use the circuit after connecting a capacitor (33 μF) to each IC.

12. Precautions on misuse

1) Erroneous connection in the case of short-circuit to V_{CC} and short-circuit to GND or load short-circuit

The AN7198Z, AN7199Z have the breakdown voltage of 20 V or higher when an short-circuit to V_{CC} and short-circuit to GND or load short-circuit occur. However, there is a possibility of destruction, then smoke emission and ignition under a special condition. Avoid misuse and erroneous connection of the circuit.

2) Power supply surge

The power supply surge breakdown voltage is evaluated by the test circuit shown in figure 10 and the surge waveform as shown in figure 11 is evaluated.

The withstanding capability against power supply surge is 80 V for the AN7198Z, AN7199Z.

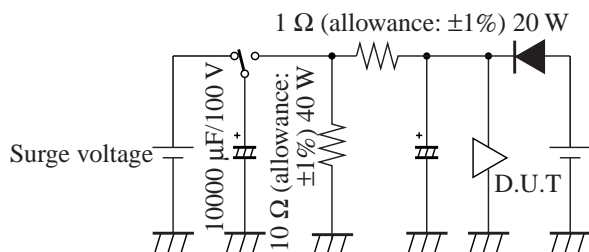

Figure 10. Power supply surge test circuit

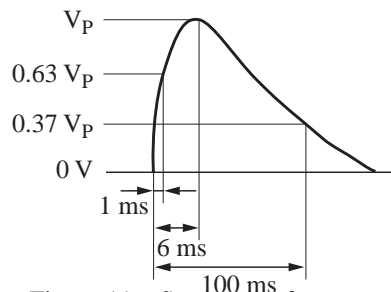

Figure 11. Surge waveform

■ Technical Information (continued)

[2] Application note (continued)

12. Precautions on misuse (continued)

3) Destruction mode for the AN7198Z, AN7199Z

The AN7198Z, AN7199Z are the power ICs with high breakdown withstanding voltage but it has been found that the destruction occurs under special conditions.

(1) GND-open short-circuit to GND

Short-circuit of the output terminal to the GND terminal of power supply when GND terminal of the IC is open, or short-circuit to GND when the GND terminal of the IC is over 0.7 V higher than the short-circuited output terminal.

At that time, if V_{CC} = more than 16 V and a voltage is also applied to STB terminal, then the destruction occurs.

(2) Short-circuit to V_{CC} of the plus and minus side output terminals at the same time

If short-circuit to V_{CC} fault occurs on both the plus and minus side output terminals at the same time with a short-circuit resistor which does not actuate the protection circuit. The power GND terminal current may exceed 10 A and the wire melts down since the current capacity of Au wire is exceeded.

(3) V_{CC} – GND reverse connection

Parasitic device is created everywhere and the circuit destruction takes place.

■ Application Circuit Example

