

TC74VHC153F, TC74VHC153FN, TC74VHC153FT

DUAL 4-CHANNEL MULTIPLEXER

The TC74VHC153 is an advanced high speed CMOS DUAL 4-CHANNEL MULTIPLEXERS fabricated with silicon gate C²MOS technology.

It achieves the high speed operation similar to equivalent Bipolar Schottky TTL while maintaining the CMOS low power dissipation.

Each of these data (1C0 - 1C3, 2C0 - 2C3) is selected by the two address inputs A and B.

Separate strobe inputs (1G, 2G) are provided for each of the two four-line sections.

The strobe input (G) can be used to inhibit the data output; the output is fixed in low level while the strobe input is held high.

An input protection circuit ensures that 0 to 5.5V can be applied to the input pins without regard to the supply voltage. This device can be used to interface 5V to 3V systems and two supply systems such as battery back up. This circuit prevents device destruction due to mismatched supply and input voltages.

FEATURES :

- High Speed..... $t_{pd} = 5.0ns(typ.)$ at $V_{CC} = 5V$
- Low Power Dissipation..... $I_{CC} = 4\mu A(Max.)$ at $T_a = 25^{\circ}C$
- High Noise Immunity..... $V_{NIH} = V_{NIL} = 28\% V_{CC} (Min.)$
- Power Down Protection is provided on all inputs.
- Balanced Propagation Delays..... $t_{pLH} \approx t_{pHL}$
- Wide Operating Voltage Range.... $V_{CC} (opr) = 2V \sim 5.5V$
- Pin and Function Compatible with 74ALS153

TRUTH TABLE

SELECT INPUTS		DATA INPUTS				STROBE	OUTPUTS
B	A	C0	C1	C2	C3	G	Y
X	X	X	X	X	X	H	L
L	L	L	X	X	X	L	L
L	L	H	X	X	X	L	H
L	H	X	L	X	X	L	L
L	H	X	H	X	X	L	H
H	L	X	X	L	X	L	L
H	L	X	X	H	X	L	H
H	H	X	X	X	L	L	L
H	H	X	X	X	H	L	H

X : Don't Care

(Note) The JEDEC SOP (FN) is not available in Japan.

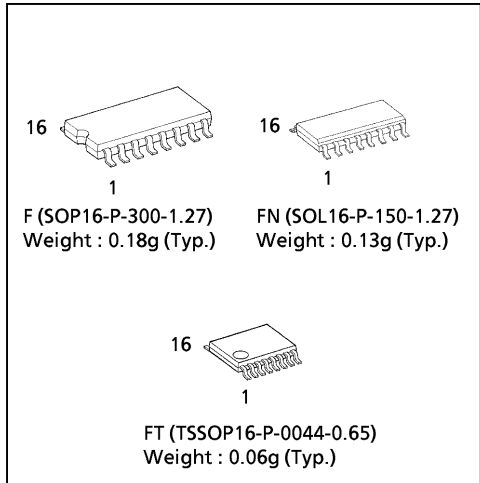

PIN ASSIGNMENT

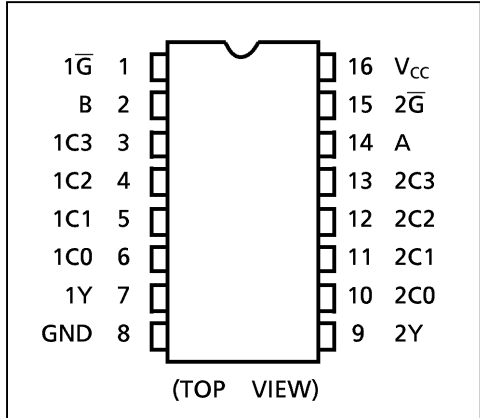

IEC LOGIC SYMBOL

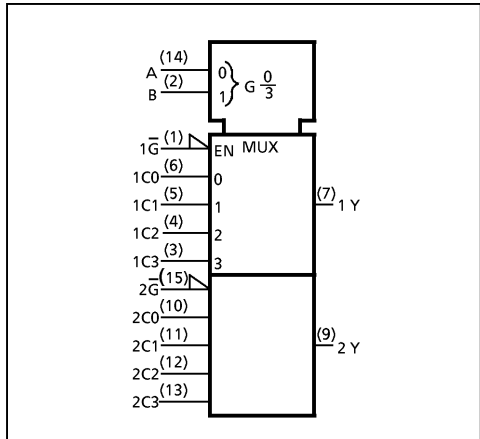

980910EBA2

● TOSHIBA is continually working to improve the quality and the reliability of its products. Nevertheless, semiconductor devices in general can malfunction or fail due to their inherent electrical sensitivity and vulnerability to physical stress. It is the responsibility of the buyer, when utilizing TOSHIBA products, to observe standards of safety, and to avoid situations in which a malfunction or failure of a TOSHIBA product could cause loss of human life, bodily injury or damage to property. In developing your designs, please ensure that TOSHIBA products are used within specified operating ranges as set forth in the most recent products specifications. Also, please keep in mind the precautions and conditions set forth in the TOSHIBA Semiconductor Reliability Handbook.

SYSTEM DIAGRAM

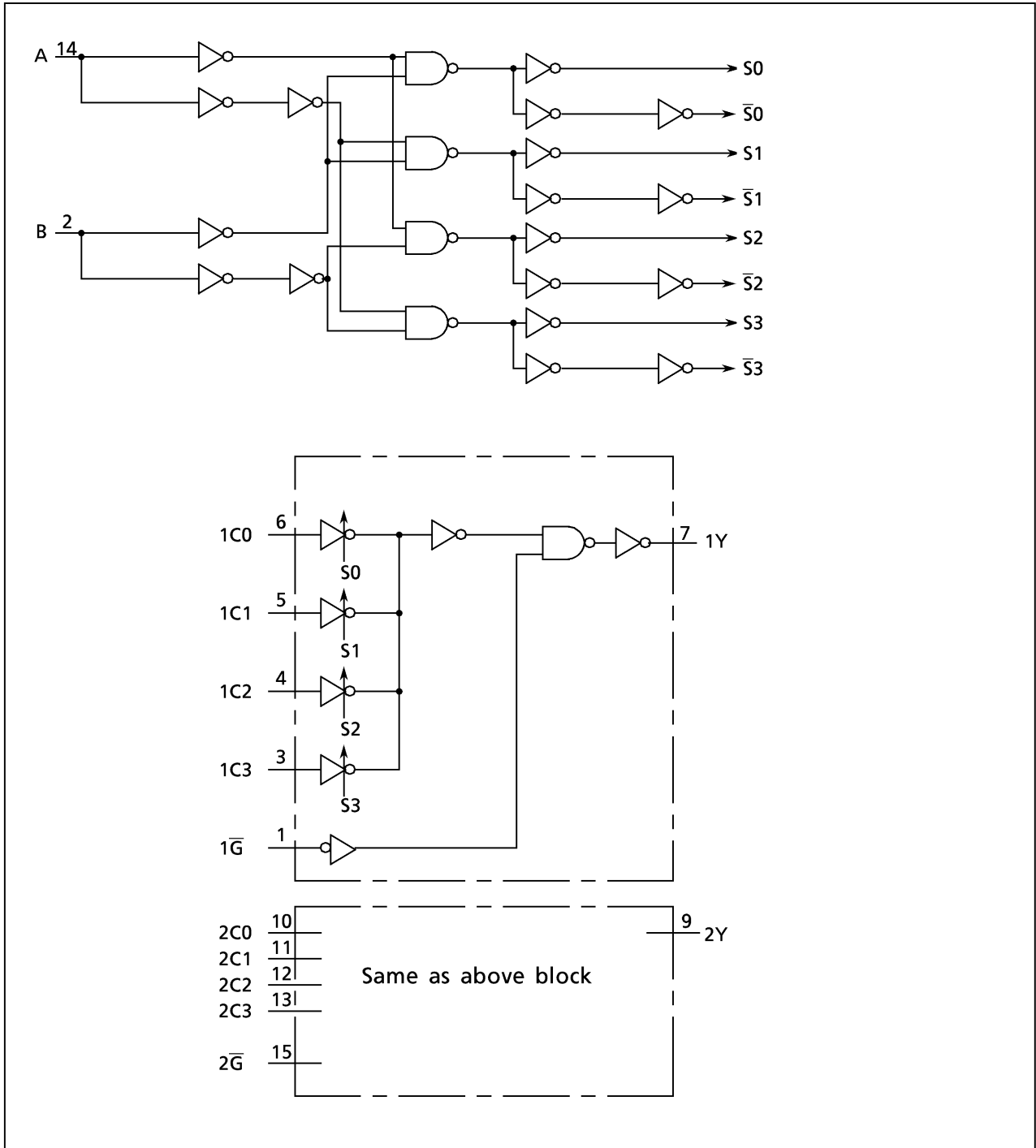

980910EBA2'

- The products described in this document are subject to the foreign exchange and foreign trade laws.
- The information contained herein is presented only as a guide for the applications of our products. No responsibility is assumed by TOSHIBA CORPORATION for any infringements of intellectual property or other rights of the third parties which may result from its use. No license is granted by implication or otherwise under any intellectual property or other rights of TOSHIBA CORPORATION or others.
- The information contained herein is subject to change without notice.

ABSOLUTE MAXIMUM RATINGS

PARAMETER	SYMBOL	VALUE	UNIT
Supply Voltage Range	V_{CC}	-0.5~7.0	V
DC Input Voltage	V_{IN}	-0.5~7.0	V
DC Output Voltage	V_{OUT}	-0.5~ $V_{CC} + 0.5$	V
Input Diode Current	I_{IK}	-20	mA
Output Diode Current	I_{OK}	±20	mA
DC Output Current	I_{OUT}	±25	mA
DC V_{CC} /Ground Current	I_{CC}	±50	mA
Power Dissipation	P_D	180	mW
Storage Temperature	T_{stg}	-65~150	°C

RECOMMENDED OPERATING CONDITIONS

PARAMETER	SYMBOL	VALUE	UNIT
Supply Voltage	V_{CC}	2.0~5.5	V
Input Voltage	V_{IN}	0~5.5	V
Output Voltage	V_{OUT}	0~ V_{CC}	V
Operating Temperature	T_{opr}	-40~85	°C
Input Rise and Fall Time	dt/dv	0~100 ($V_{CC} = 3.3 \pm 0.3V$) 0~20 ($V_{CC} = 5 \pm 0.5V$)	ns/V

DC ELECTRICAL CHARACTERISTICS

PARAMETER	SYMBOL	TEST CONDITION	V_{CC} (V)	$T_a = 25^\circ C$			$T_a = -40 \sim 85^\circ C$		UNIT		
				MIN.	TYP.	MAX.	MIN.	MAX.			
High - Level Input Voltage	V_{IH}		2.0 3.0~ 5.5	1.50 $V_{CC} \times 0.7$	— —	— —	1.50 $V_{CC} \times 0.7$	—	V		
Low - Level Input Voltage	V_{IL}		2.0 3.0~ 5.5	— —	— —	0.50 $V_{CC} \times 0.3$	— $V_{CC} \times 0.3$	0.50 $V_{CC} \times 0.3$	V		
High - Level Output Voltage	V_{OH}	$V_{IN} = V_{IH}$ or V_{IL}		$I_{OH} = -50 \mu A$	2.0	1.9	2.0	—	1.9	—	V
					3.0	2.9	3.0	—	2.9	—	
					4.5	4.4	4.5	—	4.4	—	
					3.0	2.58	—	—	2.48	—	
					4.5	3.94	—	—	3.80	—	
Low - Level Output Voltage	V_{OL}	$V_{IN} = V_{IH}$ or V_{IL}		$I_{OL} = 50 \mu A$	2.0	—	0.0	0.1	—	0.1	V
					3.0	—	0.0	0.1	—	0.1	
					4.5	—	0.0	0.1	—	0.1	
					3.0	—	—	0.36	—	0.44	
					4.5	—	—	0.36	—	0.44	
Input Leakage Current	I_{IN}	$V_{IN} = 5.5V$ or GND	0~5.5	—	—	±0.1	—	±1.0	μA		
Quiescent Supply Current	I_{CC}	$V_{IN} = V_{CC}$ or GND	5.5	—	—	4.0	—	40.0	μA		

AC ELECTRICAL CHARACTERISTICS (Input $t_r = t_f = 3ns$)

PARAMETER	SYMBOL	TEST CONDITION	Ta = 25°C			Ta = -40~85°C		UNIT	
			V _{CC} (V)	CL (pF)	MIN.	TYP.	MAX.		MIN.
Propagation Delay Time (Cn-Y)	t _{pLH} t _{pHL}		3.3 ± 0.3	15	—	7.7	11.9	1.0	14.0
				50	—	10.2	15.4	1.0	17.5
			5.0 ± 0.5	15	—	5.0	7.7	1.0	9.0
				50	—	6.5	9.7	1.0	11.0
Propagation Delay Time (A,B-Y)	t _{pLH} t _{pHL}		3.3 ± 0.3	15	—	10.8	16.7	1.0	19.5
				50	—	13.3	20.2	1.0	23.0
			5.0 ± 0.5	15	—	6.8	9.9	1.0	11.5
				50	—	8.3	11.9	1.0	13.5
Propagation Delay Time (\bar{G} -Y)	t _{pLH} t _{pHL}		3.3 ± 0.3	15	—	6.3	10.1	1.0	12.0
				50	—	8.8	13.6	1.0	15.5
			5.0 ± 0.5	15	—	4.4	6.4	1.0	7.5
				50	—	5.9	8.4	1.0	9.5
Input Capacitance	C _{IN}			—	4	10	—	10	pF
Power Dissipation Capacitance	C _{PD}	(Note 1)		—	20	—	—	—	

Note (1) C_{PD} is defined as the value of the internal equivalent capacitance which is calculated from the operating current consumption without load.

Average operating current can be obtained by the equation :

$$I_{CC(opr.)} = C_{PD} \cdot V_{CC} \cdot f_{IN} + I_{CC}$$

INPUT EQUIVALENT CIRCUIT

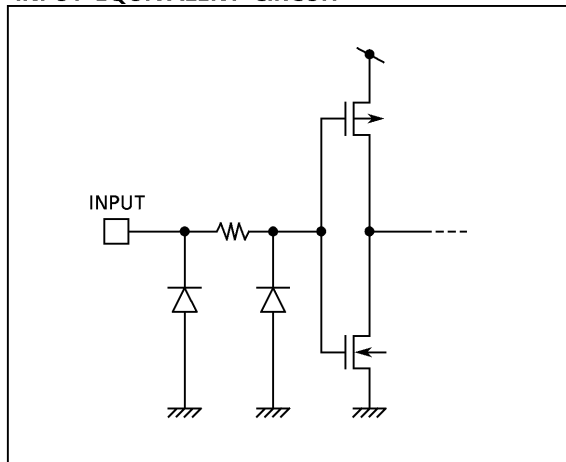

SOP 16PIN (200mil BODY) PACKAGE DIMENSIONS (SOP16-P-300-1.27)

Unit in mm

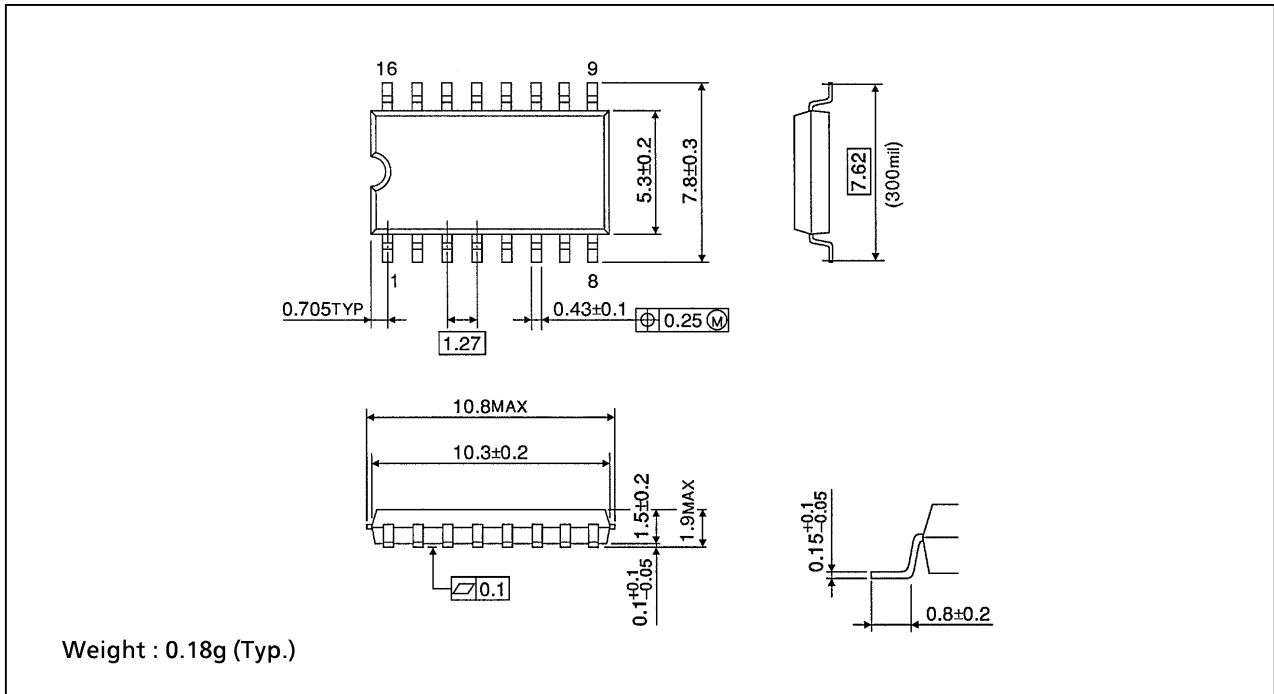

SOP 16PIN (150mil BODY) PACKAGE DIMENSIONS (SOP16-P-150-1.27)

Unit in mm

(Note) This package is not available in Japan.

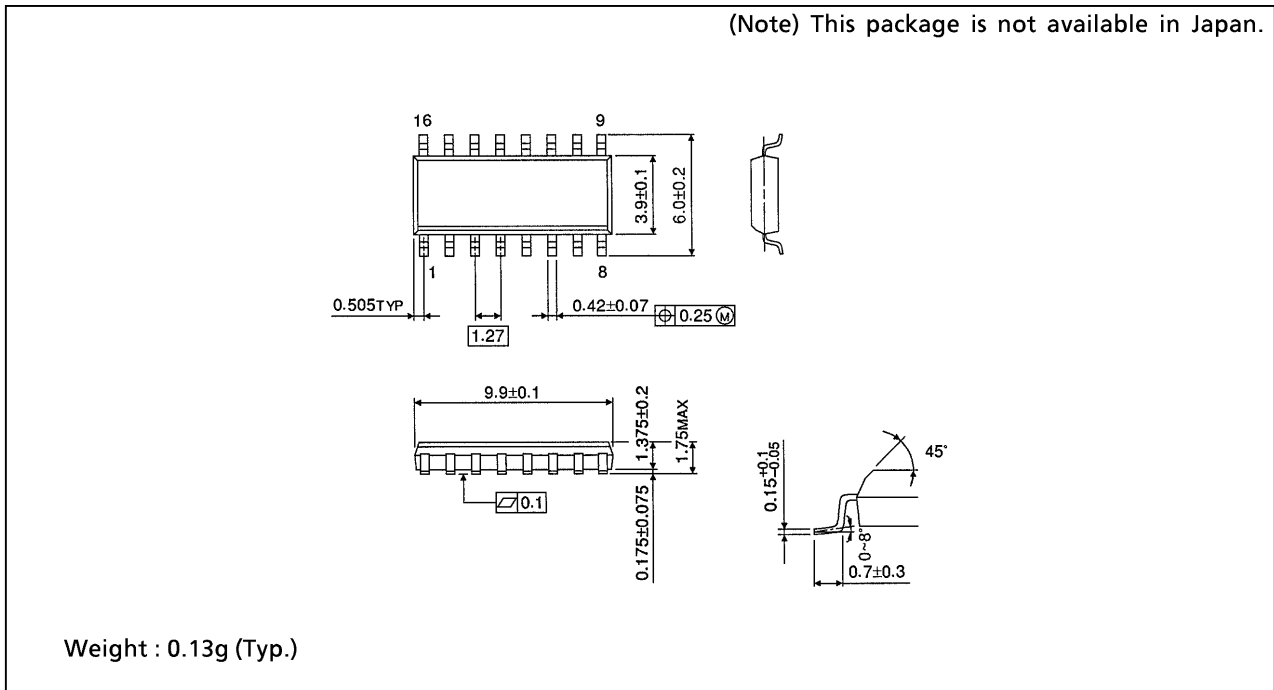

TSSOP 16PIN PACKAGE DIMENSIONS (TSSOP16-P-0044-0.65)

Unit in mm

