

TOSHIBA CMOS DIGITAL INTEGRATED CIRCUIT SILICON MONOLITHIC

TC7W66F, TC7W66FU, TC7W66FK

DUAL BILATERAL SWITCH

The TC7W66 is a high speed CMOS DUAL BILATERAL SWITCH fabricated with silicon gate CMOS technology. It consists of four independent high speed switches capable of controlling either digital or analog signals while maintaining the CMOS low power dissipation. Control input (C) is provided to control the switch. The switch turns ON while the C input is high, and the switch turns OFF while low. All inputs are equipped with protection circuits against static discharge or transient excess voltage.

FEATURES

- High Speed $t_{pd} = 7\text{ns}$ (Typ.) at $V_{CC} = 5\text{V}$
- Low Power Dissipation $I_{CC} = 1\mu\text{A}$ (Max.) at $T_a = 25^\circ\text{C}$
- High Noise Immunity $V_{NIH} = V_{NIL} = 28\% V_{CC}$ (Min.)
- Low ON Resistance $R_{ON} = 50\Omega$ (Typ.) at $V_{CC} = 9\text{V}$
- High Degree of Linearity $\text{THD} = 0.05$ (Typ.) at $V_{CC} = 5\text{V}$
- Pin and Function Compatible with TC4W66

MARKING

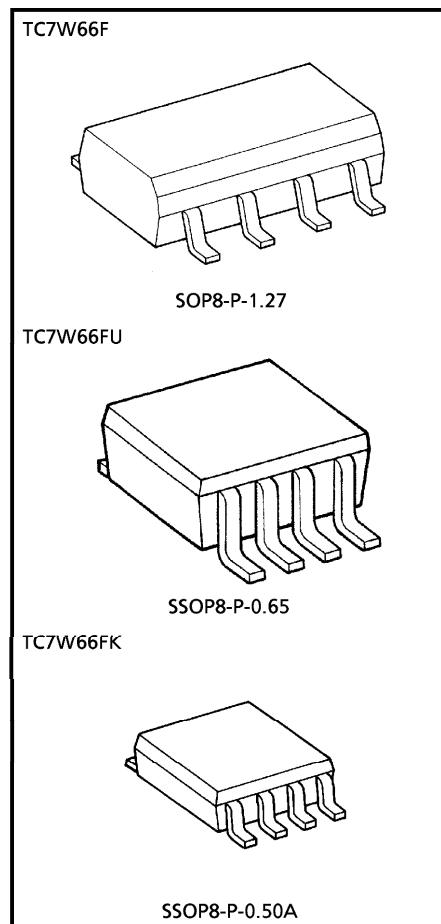
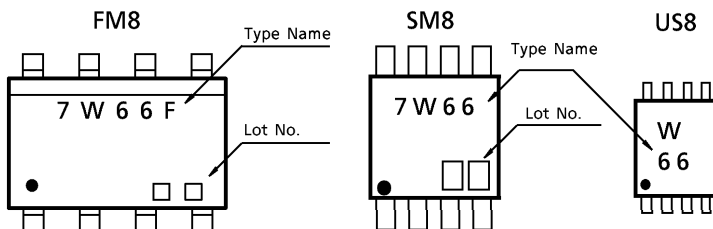

Weight	
SOP8-P-1.27	: 0.05g (Typ.)
SSOP8-P-0.65	: 0.02g (Typ.)
SSOP8-P-0.50A	: 0.01g (Typ.)

980910EBA1

- TOSHIBA is continually working to improve the quality and the reliability of its products. Nevertheless, semiconductor devices in general can malfunction or fail due to their inherent electrical sensitivity and vulnerability to physical stress. It is the responsibility of the buyer, when utilizing TOSHIBA products, to observe standards of safety, and to avoid situations in which a malfunction or failure of a TOSHIBA product could cause loss of human life, bodily injury or damage to property. In developing your designs, please ensure that TOSHIBA products are used within specified operating ranges as set forth in the most recent products specifications. Also, please keep in mind the precautions and conditions set forth in the TOSHIBA Semiconductor Reliability Handbook.
- The products described in this document are subject to the foreign exchange and foreign trade laws.
- The information contained herein is presented only as a guide to the applications of our products. No responsibility is assumed by TOSHIBA CORPORATION for any infringements of intellectual property or other rights of the third parties which may result from its use. No license is granted by implication or otherwise under any intellectual property or other rights of TOSHIBA CORPORATION or others.
- The information contained herein is subject to change without notice.

PIN ASSIGNMENT (TOP VIEW)

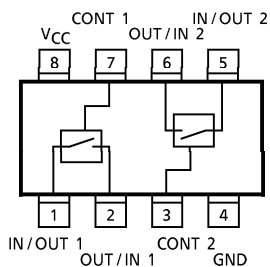

TRUTH TABLE

CONTROL	SWITCH FUNCTION
H	ON
L	OFF

MAXIMUM RATINGS (Ta = 25°C)

CHARACTERISTIC	SYMBOL	RATING	UNIT
Supply Voltage Range	V _{CC}	-0.5~13	V
Control Input Voltage	V _{IN}	-0.5~V _{CC} + 0.5	V
Switch I/O Voltage	V _{OUT}	-0.5~V _{CC} + 0.5	V
Control Input Diode Current	I _{IK}	± 20	mA
I/O Diode Current	I _{OK}	± 20	mA
Switch Through Current	I _{OUT}	± 25	mA
DC V _{CC} /GND Current	I _{CC}	± 25	mA
Power Dissipation	P _D	300 (FM8, SM8)	mW
		200 (US8)	
Storage Temperature	T _{stg}	-65~150	°C
Lead Temperature (10 s)	T _L	260	°C

LOGIC SYMBOL

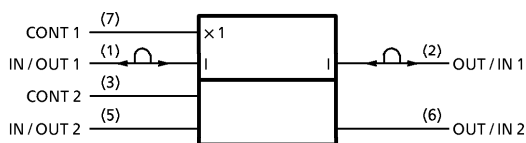

LOGIC DIAGRAM (1/2 TC7W66)

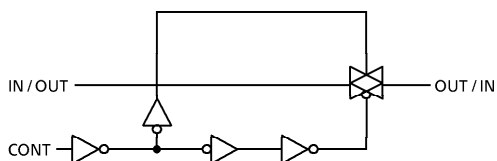

RECOMMENDED OPERATING CONDITIONS

CHARACTERISTIC	SYMBOL	RATING	UNIT
Supply Voltage	V_{CC}	2~12	V
Control Input Voltage	V_{IN}	0~ V_{CC}	V
Switch I/O Voltage	$V_{I/O}$	0~ V_{CC}	V
Operating Temperature	T_{opr}	-40~85	°C
Input Rise and Fall Time	t_r, t_f	0~1000 ($V_{CC} = 2.0V$)	ns
		0~500 ($V_{CC} = 4.5V$)	
		0~400 ($V_{CC} = 6.0V$)	
		0~250 ($V_{CC} = 10.0V$)	

DC ELECTRICAL CHARACTERISTICS

CHARACTERISTIC	SYMBOL	TEST CONDITION	$T_a = 25^\circ C$			$T_a = -40 \sim 85^\circ C$		UNIT	
			V_{CC}	MIN.	TYP.	MAX.	MIN.		MAX.
High-Level Control Input Voltage	V_{IHC}		2.0	1.5	—	—	1.5	—	V
			4.5	3.15	—	—	3.15	—	
			9.0	6.3	—	—	6.3	—	
			12.0	8.4	—	—	8.4	—	
Low-Level Control Input Voltage	V_{ILC}		2.0	—	—	0.5	—	0.5	V
			4.5	—	—	1.35	—	1.35	
			9.0	—	—	2.7	—	2.7	
			12.0	—	—	3.6	—	3.6	
ON Resistance	R_{ON}	$V_{IN} = V_{IHC}$ $V_{I/O} = V_{CC}$ to GND $I_{I/O} \leq 1mA$	4.5	—	96	170	—	200	Ω
			9.0	—	55	85	—	100	
			12.0	—	45	80	—	90	
		$V_{IN} = V_{IHC}$ $V_{I/O} = V_{CC}$ or GND $I_{I/O} \leq 1mA$	2.0	—	160	—	—	—	
			4.5	—	70	100	—	130	
			9.0	—	50	75	—	95	
Difference of ON Resistance Between Switches	ΔR_{ON}	$V_{IN} = V_{IHC}$ $V_{I/O} = V_{CC}$ to GND $I_{I/O} \leq 1mA$	4.5	—	10	—	—	—	Ω
			9.0	—	5	—	—	—	
			12.0	—	5	—	—	—	
Input/Output Leakage Current (SWITCH OFF)	I_{OFF}	$V_{OS} = V_{CC}$ or GND $V_{IS} = GND$ or V_{CC} $V_{IN} = V_{ILC}$	12.0	—	—	± 100	—	± 1000	nA
Switch Input Leakage Current (SWITCH ON OUTPUT OPEN)	I_{IZ}	$V_{OS} = V_{CC}$ or GND $V_{INH} = V_{IHC}$	12.0	—	—	± 100	—	± 1000	nA
Control Input Current	I_{IN}	$V_{IN} = V_{CC}$ or GND	6.0	—	—	± 100	—	± 1000	nA
Quiescent Supply Current	I_{CC}	$V_{IN} = V_{CC}$ or GND	6.0	—	—	1.0	—	10.0	μA
			9.0	—	—	4.0	—	40.0	
			12.0	—	—	8.0	—	80.0	

AC ELECTRICAL CHARACTERISTICS ($C_L = 50\text{pF}$, Input $t_r = t_f = 6\text{ns}$)

CHARACTERISTIC	SYMBOL	TEST CONDITION	V_{CC}	$T_a = 25^\circ\text{C}$			$T_a = -40 \sim 85^\circ\text{C}$		UNIT
				MIN.	TYP.	MAX.	MIN.	MAX.	
Phase Difference Between Input and Output	$\phi_{I/O}$		2.0	—	10	50	—	65	ns
			4.5	—	4	10	—	13	
			9.0	—	3	8	—	10	
			12.0	—	3	7	—	9	
Output Enable Time	t_{pZL} t_{pZH}	$R_L = 1\text{k}\Omega$	2.0	—	18	100	—	125	ns
			4.5	—	8	20	—	25	
			9.0	—	6	12	—	22	
			12.0	—	6	12	—	18	
Output Disable Time	t_{pLZ} t_{pHZ}	$R_L = 1\text{k}\Omega$	2.0	—	20	115	—	145	ns
			4.5	—	10	23	—	29	
			9.0	—	8	20	—	25	
			12.0	—	8	18	—	22	
Maximum Control Input Frequency		$R_L = 1\text{k}\Omega$ $C_L = 15\text{pF}$ $V_{OUT} = 1/2V_{CC}$	2.0	—	30	—	—	—	MHz
			4.5	—	30	—	—	—	
			9.0	—	30	—	—	—	
			12.0	—	30	—	—	—	
Control Input Capacitance	C_{IN}		—	5	10	—	10	pF	
Switch Terminal Capacitance	$C_{I/O}$		—	6	—	—	—	pF	
Feed Through Capacitance	C_{IOS}		—	0.5	—	—	—	pF	
Power Dissipation Capacitance	C_{PD}	(Note 1)	—	15	—	—	—	pF	

(Note 1) : C_{PD} is defined as the value of the internal equivalent capacitance which is calculated from the operating current consumption without load.

Average operating current can be obtained by the equation :

$$I_{CC(\text{opr})} = C_{PD} \cdot V_{CC} \cdot f_{IN} + I_{CC}/2$$

ANALOG SWITCH CHARACTERISTICS (GND = 0V, Ta = 25°C)

CHARACTERISTIC	SYMBOL	TEST CONDITION	V _{CC}	TYP.	UNIT
Sine Wave Distortion (T.H.D)		f _{IN} = 1kHz, V _{IN} = 4.0Vp-p @V _{CC} = 4.5V R _L = 10kΩ, V _{IN} = 8.0Vp-p @V _{CC} = 9.0V C _L = 50pF	4.5	0.05	%
			9.0	0.04	
Frequency Response (Switch ON)	f _{MAX}	Adjust f _{IN} voltage to obtain 0dBm at V _{OS} Increase f _{IN} Frequency until dB Meter reads -3dB R _L = 50Ω, C _L = 10pF f _{IN} = 1MHz, Sine Wave	4.5	200	MHz
			9.0	200	
Feedthrough Attenuation (Switch OFF)		V _{in} is centered at V _{CC} /2 Adjust input for 0dBm R _L = 600Ω, C _L = 50pF f _{IN} = 1MHz, Sine Wave	4.5	-60	dB
			9.0	-60	
Crosstalk (Control Input to Signal Output)		R _L = 600Ω, C _L = 50pF f _{IN} = 1MHz, Square Wave (t _r = t _f = 6ns)	4.5	60	mV
			9.0	100	
Crosstalk (Between any switches)		Adjust V _{IN} to obtain 0dBm at Input R _L = 600Ω, C _L = 50pF f _{IN} = 1MHz, Sine Wave	4.5	-60	dB
			9.0	-60	

SWITCHING CHARACTERISTICS TEST CIRCUITS

1. t_{pLZ} , t_{pHZ} , t_{pZL} , t_{pZH}

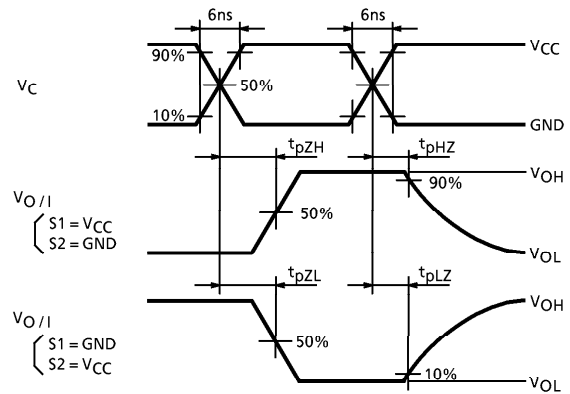
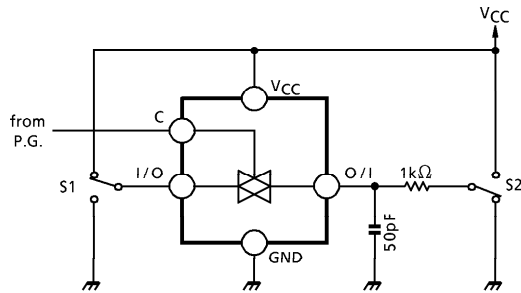

2. CROSS TALK (CONTROL INPUT-SWITCH OUTPUT)

$f_{in} = 1\text{MHz}$, $\text{duty} = 50\%$, $t_r = t_f = 6\text{ns}$

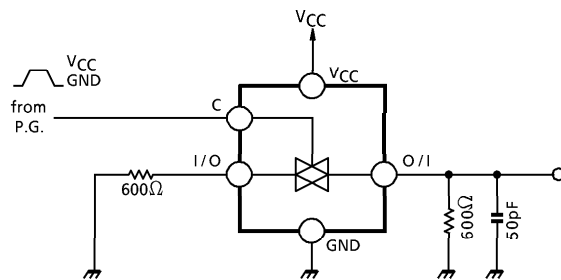

3. FEEDTHROUGH ATTENUATION

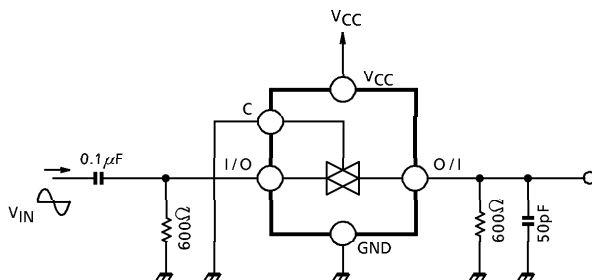

4. Clos, $C_{I/O}$

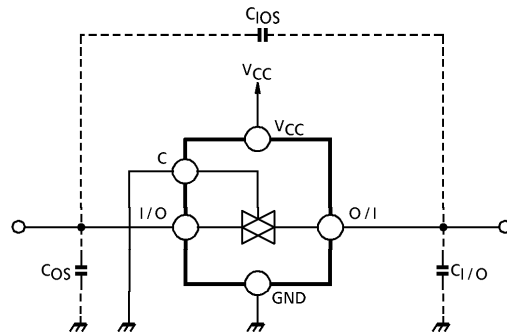

5. CROSS TALK (BETWEEN ANY TWO SWITCHES)

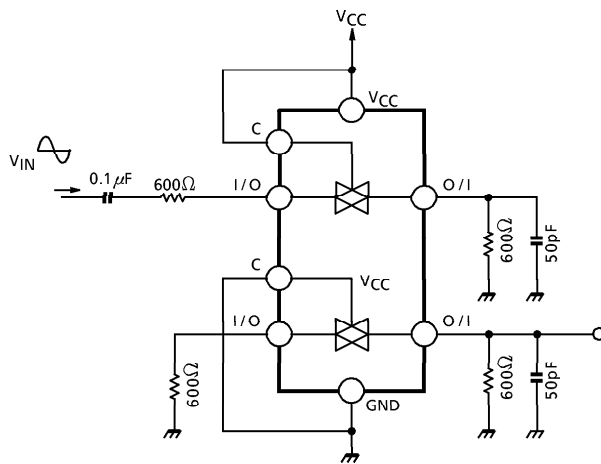

6. FREQUENCY RESPONSE (SWITCH ON)

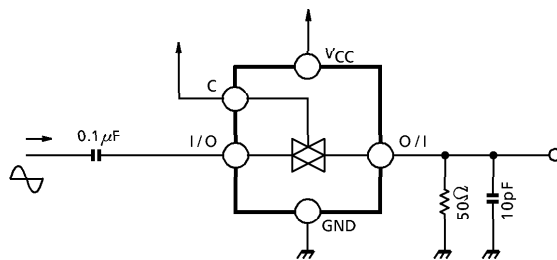

OUTLINE DRAWING
SOP8-P-1.27

Unit : mm

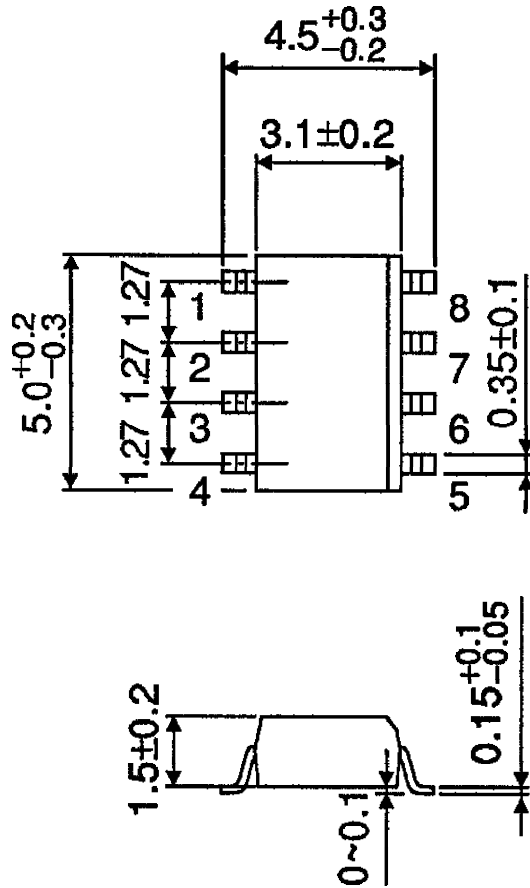

Weight : 0.05g (Typ.)

