

# LINEAR INTEGRATED CIRCUITS

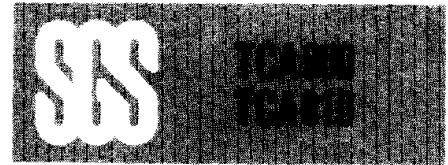

## MOTOR SPEED REGULATORS

The TCA 900 and TCA 910 are monolithic integrated circuits in Jedec TO-126 plastic package. They are designed for use as speed regulators for DC motors of record players, cassette recorders and players. The TCA 900 is particularly suitable for battery operated portable equipments, and the TCA 910 for car-battery and mains operations.

### ABSOLUTE MAXIMUM RATINGS

|           |  | TCA 900 | TCA 910       |
|-----------|--|---------|---------------|
| $V_s$     | Supply voltage   | 14V     | 20V           |
| $P_{tot}$ | Total power dissipation at $T_{amb} = 70^\circ\text{C}$<br>at $T_{case} = 100^\circ\text{C}$ |         | 0.8 W<br>5 W  |
| $T_{stg}$ | Storage temperature  |         | -55 to 150 °C |
| $T_j$     | Junction temperature   |         | 150 °C        |

ORDERING NUMBERS: TCA 900  
TCA 910

### MECHANICAL DATA

Dimensions in mm

Pin 3 connected to metal part of mounting surface

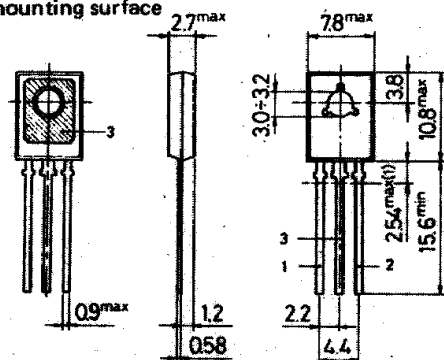

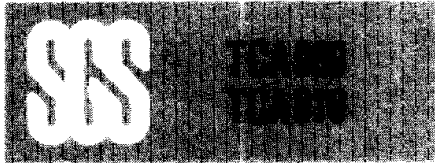

## CONNECTION AND SCHEMATIC DIAGRAMS

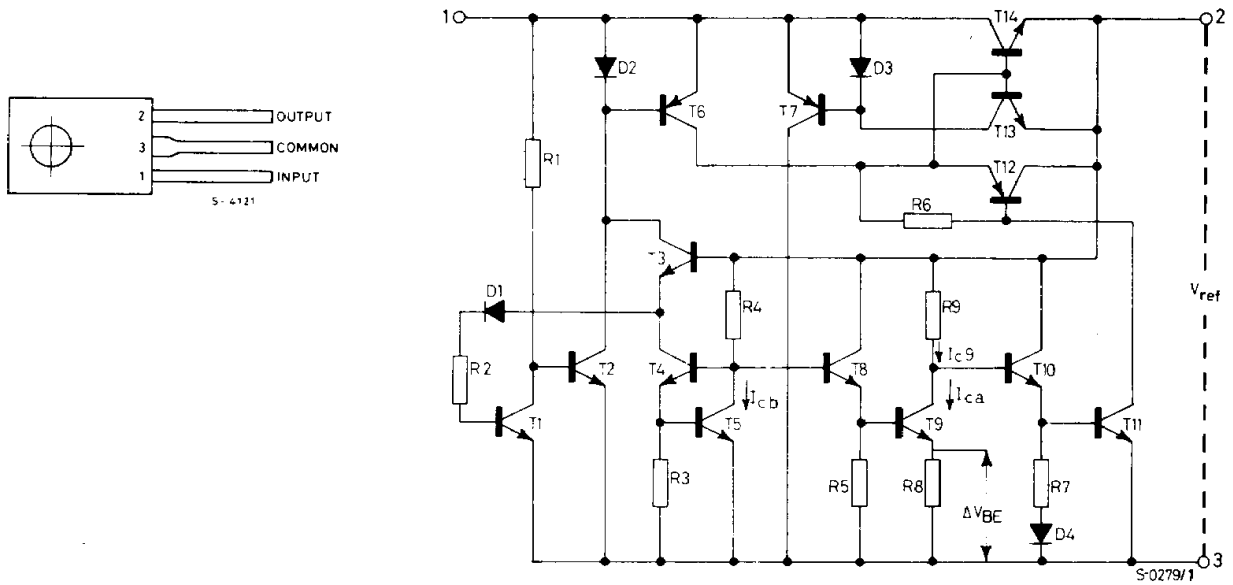

## THERMAL DATA

|                         |                                     |      |     |                      |
|-------------------------|-------------------------------------|------|-----|----------------------|
| $R_{th \text{ j-case}}$ | Thermal resistance junction-case    | Typ. | 10  | $^{\circ}\text{C/W}$ |
| $R_{th \text{ j-amb}}$  | Thermal resistance junction-ambient | Typ. | 100 | $^{\circ}\text{C/W}$ |

## ELECTRICAL CHARACTERISTICS (Refer to the test circuit, $T_{amb} = 25^{\circ}\text{C}$ unless otherwise specified)

| Parameter | Test conditions   | Min. | Typ. | Max. | Unit |
|-----------|---|------|------|------|------|
| $V_{ref}$ | Reference voltage (between pins 2 and 3)<br>$V_s = 5.5\text{V}$<br>$I_m = 70\text{mA}$<br>$R_T = 0$ |      | 2.6  |      | V    |
| $I_{d3}$  | Quiescent current (at pin 3)<br>$V_s = 5.5\text{V}$<br>$I_m = 0$<br>$R_T = 0$                       |      | 2.6  |      | mA   |
| $V_m$     | Output voltage (for TCA 900 only)<br>$V_s = 5.5\text{V}$<br>$I_m = 70\text{mA}$<br>$R_T = 91\Omega$ |      | 3.6  | 3.9  | V    |
| $V_m$     | Output voltage (for TCA 910 only)<br>$V_s = 9\text{V}$<br>$I_m = 70\text{mA}$<br>$R_T = 270\Omega$  |      | 5.6  | 6.3  | V    |

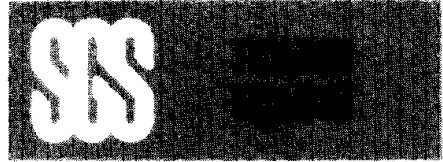

## ELECTRICAL CHARACTERISTICS (continued)

| Parameter   | Test conditions  | Min. | Typ.  | Max. | Unit |
|---|--|------|-------|------|------|
| $V_{1-2}$ Dropout voltage   | $\Delta V_m/V_m = -1\%$<br>$I_m = 70 \text{ mA}$<br>$R_T = 91\Omega$                             |      | 1.2   |      | V    |
| $I_2$ Limiting output current (at pin 2)                                  | $V_s = 5.5\text{V}$<br>$V_{2-3} = 0$   |      | 400   |      | mA   |
| $k = \Delta I_2/\Delta I_3$   | $V_s = 5.5\text{V}$<br>$I_2 = 70 \text{ mA}$<br>$\Delta I_2 = \pm 10 \text{ mA}$<br>$R_T = 0$    |      | 8.5   |      | —    |
| $\frac{\Delta V_m}{V_m} / \Delta V_s$ Line regulation (for TCA 900 only)  | $V_s = 5.5\text{V to } 12\text{V}$<br>$I_m = 70 \text{ mA}$<br>$R_T = 91\Omega$                  |      | 0.1   |      | %/V  |
| $\frac{\Delta V_m}{V_m} / \Delta V_s$ Line regulation (for TCA 910 only)  | $V_s = 10\text{V to } 16\text{V}$<br>$I_m = 70 \text{ mA}$<br>$R_T = 270\Omega$                  |      | 0.1   |      | %/V  |
| $\frac{\Delta V_m}{V_m} / \Delta I_m$ Load regulation                     | $V_s = 5.5\text{V}$<br>$I_m = 40 \text{ to } 100 \text{ mA}$<br>$R_T = 0$                        |      | 0.005 |      | %/mA |
| $\frac{\Delta V_{ref}}{V_{ref}} / \Delta T_{amb}$ Temperature coefficient | $V_{1-3} = 5.5\text{V}$<br>$I_2 = 70 \text{ mA}$<br>$T_{amb} = -20 \text{ to } 70^\circ\text{C}$ |      | 0.01  |      | %/°C |

Fig. 1 - Test circuit.

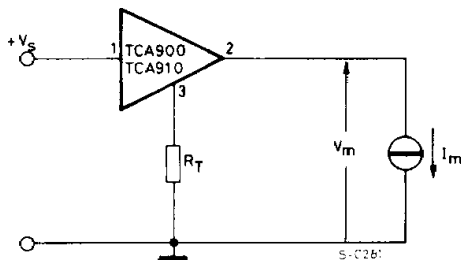
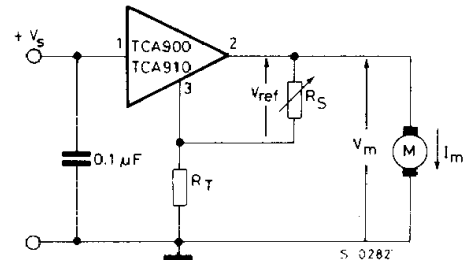

Fig. 2 - Typical application circuit.



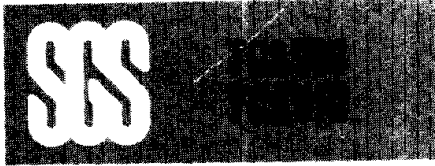

Fig. 3 - Normalized k vs.  $I_2$ .

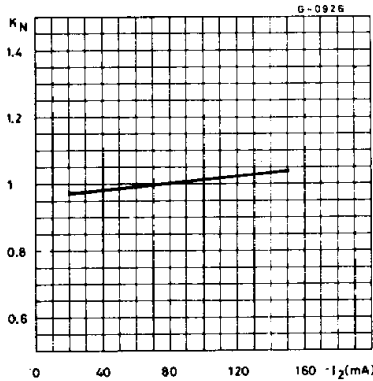

Fig. 4 - Dropout voltage vs. output current

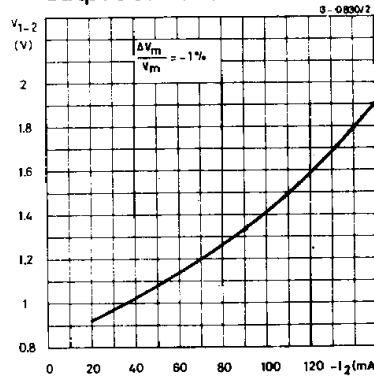
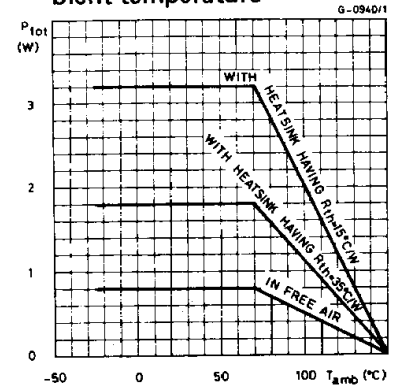

Fig. 5 - Maximum allowable power dissipation vs. ambient temperature



### APPLICATION INFORMATION

The regulator supplies the motor in such a way as to keep its speed constant, independent of supply voltage, applied torque and ambient temperature variations.

The basic equation for the motor is:

$$V_m = E_0 + R_m I_m = a_1 n + a_2 c$$

Where:  $V_m$  = supply voltage applied to the motor  
 $E_0$  = back electromotive force  
 $n$  = motor speed (r.p.m.)  
 $R_m$  = internal resistance (of the motor)  
 $I_m$  = current absorbed (by the motor)  
 $a_1$  and  $a_2$  = constants  
 $c$  = drive torque

A voltage supply with the following characteristics

$E = E_0$   $E$  = electromotive force  
 $R_o = -R_m$   $R_o$  = output resistance

gives performance required.

This means that a variation in current absorbed by the motor, due to a variation in torque applied, causes a proportional variation in regulator output voltage. In fig. 6 is shown the minimum allowable  $E_0$  vs.  $R_T$ . The TCA 900 and TCA 910 give a reference constant voltage  $V_{ref}$  (between pins 2 and 3) independent of variations of  $V_s$ ,  $I_2$  and ambient temperature.

They also give:  $I_3 = I_{d3} + I_2/k$

Where:  $I_3$  = total current at pin 3  
 $I_{d3}$  = quiescent current at pin 3 ( $I_2 = 0$ )  
 $I_2$  = current at pin 2  
 $k$  = constant

The output voltage  $V_m$ , applied to the motor has the following value:

$$V_m = \underbrace{V_{ref} + R_T \left[ \frac{V_{ref}}{R_s} \left( 1 + \frac{1}{k} \right) + I_{d3} \right]}_{\text{Term 1}} + \underbrace{\frac{I_m}{k} R_T}_{\text{Term 2}}$$

Term 1 equals  $E_0$  and fixes the motor speed by means of the variable resistor  $R_s$ ;

Term 2  $\frac{I_m}{k} \cdot R_T$  equals the term  $R_m \cdot I_m$  and, therefore, compensates variations of torque applied. Complete compensation is achieved when:

$$R_T = k R_m$$

$I_f R_{T \max} > k R_{m \min}$  instability may occur.

Fig. 6 - Minimum  $E_0$  allowable vs.  $R_T$

