

# Pulse width controller for portable CD players

## BA3890F

The BA3890F is an interface IC that provides gain for the PWM signal pulses used in digital servo systems, and allows gain adjustment to eliminate the dependence on battery voltage.

### ●Applications

Portable CD players CD-ROM, and MD players

### ●Features

- 1) Amplifies the pulse width in accordance with the battery voltage.
- 2) Gain switching is possible via the control pin.

### ●Absolute maximum ratings (Ta = 25°C)

Parameter	Symbol	Limits	Unit
Power supply voltage	V <sub>CC</sub>	4.5	V
Power dissipation	P <sub>d</sub>	450*	mW
Operating temperature	T <sub>opr</sub>	-15~+50	°C
Storage temperature	T <sub>stg</sub>	-55~+125	°C
Input pin voltage	V <sub>IN1</sub>	9.0	V

\* Reduced by 4.5mW for each increase in Ta of 1°C over 25°C.

### ●Recommended operating conditions

Parameter	Symbol	Limits	Unit
Power supply voltage	V <sub>CC</sub>	2.9~3.6	V

## ●Block diagram

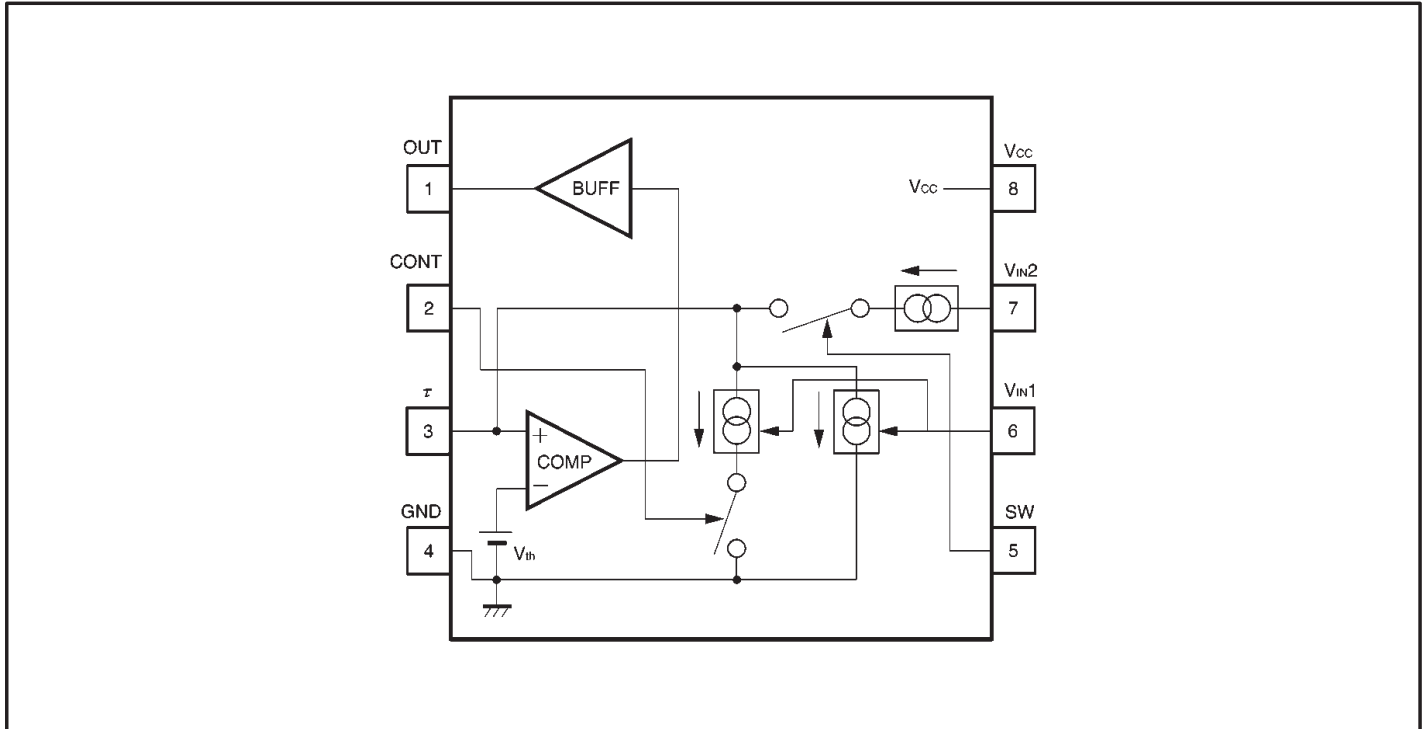
●Electrical characteristics (Unless otherwise noted,  $T_a = 25^\circ\text{C}$  and  $V_{CC} = 3.0\text{V}$ )

Parameter	Symbol	Min.	Typ.	Max.	Unit	Conditions	
Circuit current	$I_Q$	1.4	2.1	2.8	mA	$V_{IN1}=3.0\text{V}$ $V_{SW}=0.4\text{V}$ , $V_{CONT}=0.4\text{V}$	
$\tau$ pin current 1	ON	$I_{\tau ON1}$	-150	-130	-110	$\mu\text{A}$	$V_{IN1}=3.0\text{V}$ , $V_{\tau}=1.0\text{V}$ $V_{SW}=1.2\text{V}$ , $V_{CONT}=0.4\text{V}$
	OFF	$I_{\tau OFF1}$	70	85	100	$\mu\text{A}$	$V_{IN1}=3.0\text{V}$ , $V_{\tau}=1.0\text{V}$ $V_{SW}=0.4\text{V}$ , $V_{CONT}=0.4\text{V}$
$\tau$ pin current 2	ON	$I_{\tau ON2}$	-65	-50	-35	$\mu\text{A}$	$V_{IN1}=3.0\text{V}$ , $V_{\tau}=1.0\text{V}$ $V_{SW}=1.2\text{V}$ , $V_{CONT}=1.2\text{V}$
	OFF	$I_{\tau OFF2}$	135	160	185	$\mu\text{A}$	$V_{IN1}=3.0\text{V}$ , $V_{\tau}=1.0\text{V}$ $V_{SW}=0.4\text{V}$ , $V_{CONT}=1.2\text{V}$
Comparator threshold	$V_{th}$	0.100	0.125	0.150	V	$V_{IN1}=3.0\text{V}$ , $V_{OUT}=1.5\text{V}$ $V_{SW}=0.4\text{V}$ , $V_{CONT}=0.4\text{V}$	
Output voltage	High	$V_{OH}$	2.8	3.0	—	V	$V_{IN1}=3.0\text{V}$ , $V_{\tau}=0.15\text{V}$ $V_{SW}=0.4\text{V}$ , $V_{CONT}=0.4\text{V}$
	Low	$V_{OL}$	—	0.12	0.5	V	$V_{IN1}=3.0\text{V}$ , $V_{\tau}=0.10\text{V}$ $V_{SW}=0.4\text{V}$ , $V_{CONT}=0.4\text{V}$
$V_{IN1}$ leak current at standby	$I_{IN1(L)}$	—	0	5	$\mu\text{A}$	$V_{IN1}=0\text{V}$ , $V_{IN1}=3.0\text{V}$ $V_{SW}=0.4\text{V}$ , $V_{CONT}=0.4\text{V}$	
Switch pin input detector level	High	$V_{SWH}$	1.2	—	—	V	—
	Low	$V_{SWL}$	—	—	0.4	V	—
CONT pin control voltage	High	$V_{CONTH}$	1.2	—	—	V	—
	Low	$V_{CONTL}$	—	—	0.4	V	—

©Not designed for radiation resistance.

● Measurement circuit

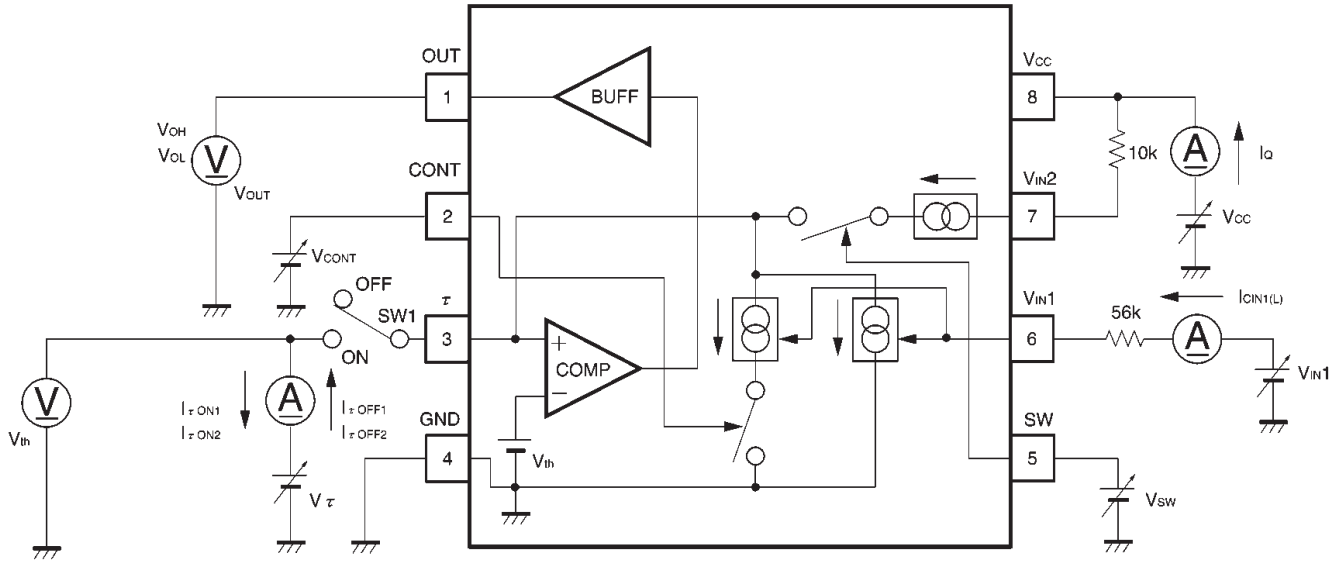

SW1 is only off when I<sub>τ</sub> and I<sub>τ ON1(L)</sub> are being measured.

Fig.1

● Application example

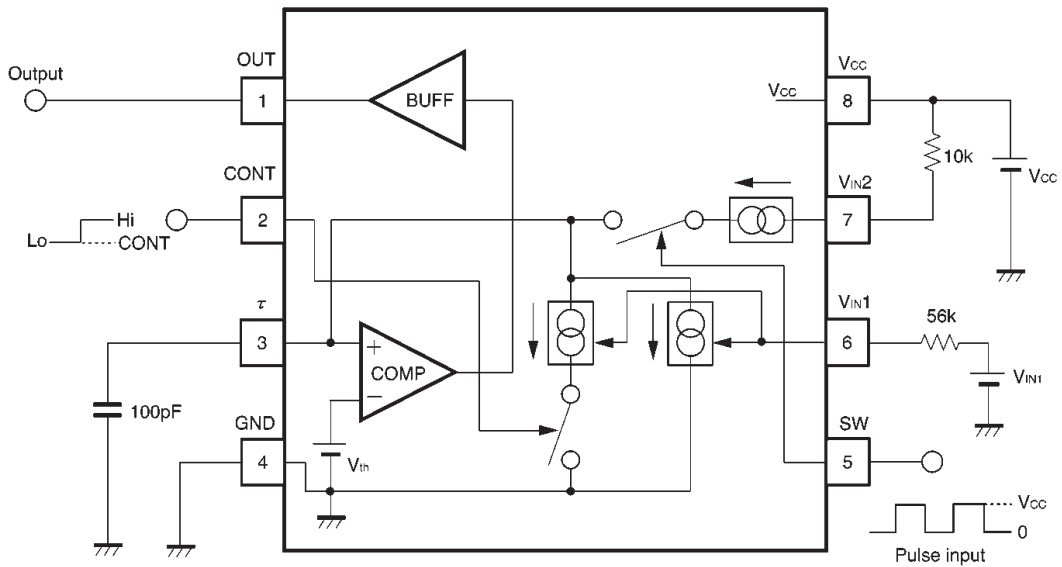

Fig.2

●Electrical characteristic curves

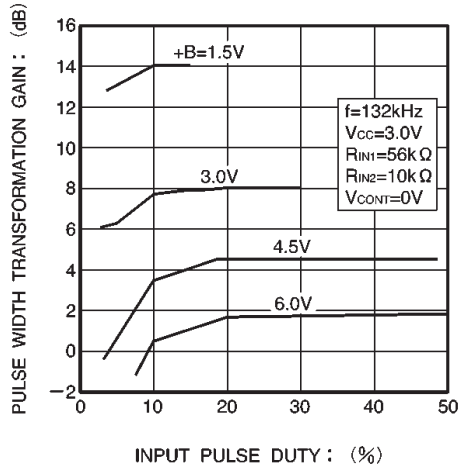

Fig.3 Gain vs. duty

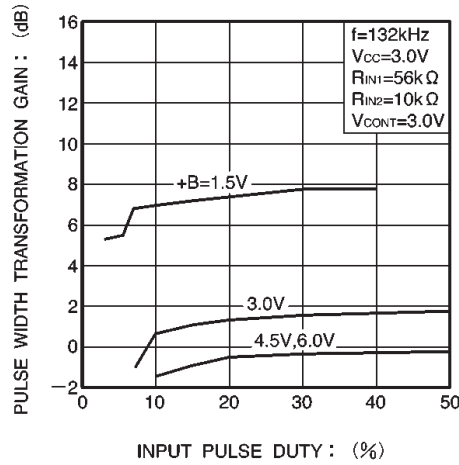

Fig.4 Gain vs. duty

●External dimensions (Units: mm)

