

**Small Form Factor
Multimode 850 nm 1.0625 GBd Fibre Channel
1.25 Gigabit Ethernet Transceiver
2x5 Pinning with LC™ Connector**

V23818-K305-Lxx

Features

- Small Form Factor transceiver
- Complies with Fibre Channel and Gigabit Ethernet standards
- Excellent EMI performance
- RJ-45 style LC™ connector system
- Available with or without collar
- Half the size of SC Duplex 1x9 transceiver
- Single power supply (3.3 V)
- Extremely low power consumption, 445 mW typical
- LVPECL differential inputs and outputs
- AC/AC coupling in accordance to SFF MSA or optional DC/DC coupling version
- Optimized for 62.5/50 µm graded index fiber
- For distances of up to 700 m
- Multisource 2x5 footprint¹⁾
- Small size for high port density
- UL-94 V-0 certified
- ESD Class 1 per MIL-STD 883D Method 3015.7
- Compliant with FCC (Class B) and EN 55022
- Class 1 FDA and IEC laser safety compliant

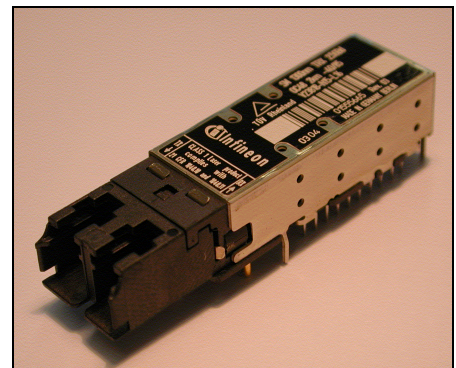
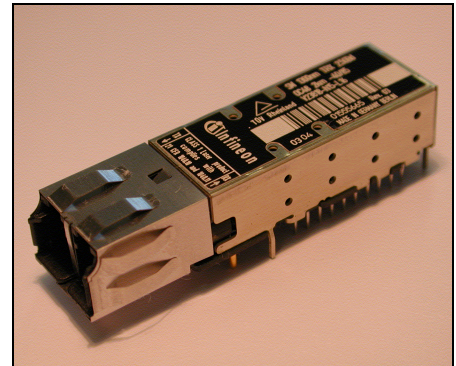

¹⁾ Current MSA documentation can be found at www.infineon.com/fiberoptics

LC™ is a trademark of Lucent

Part Number	Voltage	Signal Detect	Collar	Input	Output
V23818-K305-L17	3.3 V	LVTTL	yes	DC	DC
V23818-K305-L57				AC	AC
V23818-K305-L15	3.3 V	LVTTL	no	DC	DC
V23818-K305-L55				AC	AC

Pin Configuration

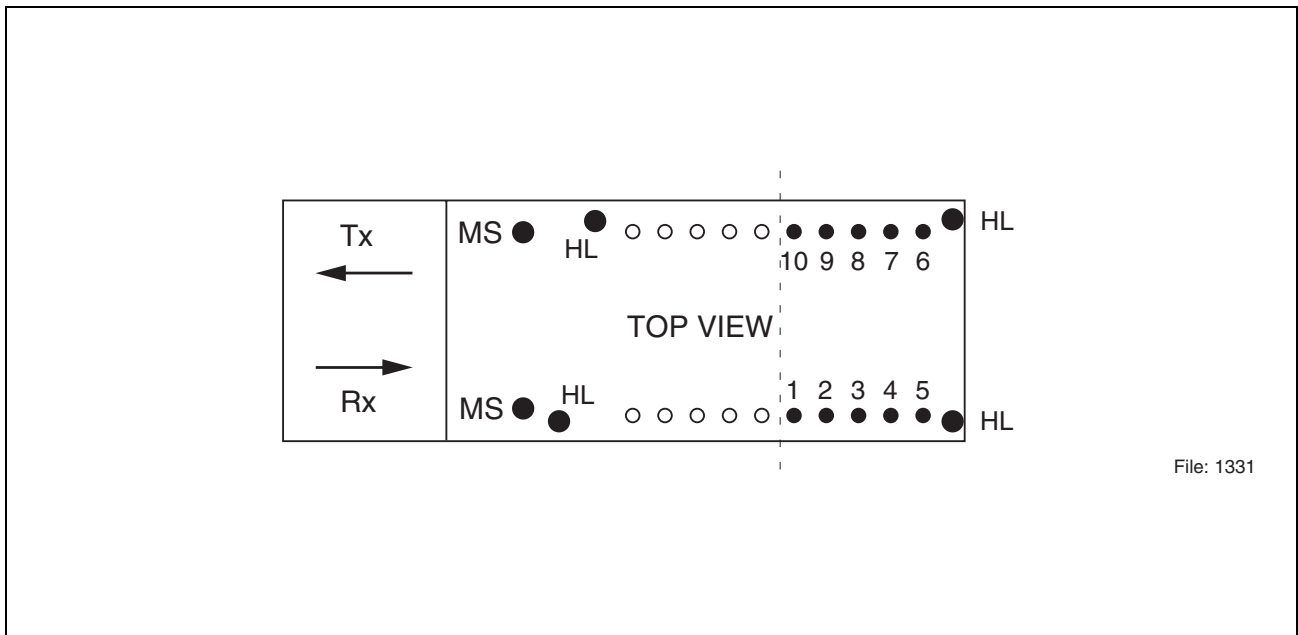

File: 1331

Figure 1

Pin Description

Pin No.	Symbol	Level/Logic	Description
1	V_{EEr}	Ground	Receiver signal ground
2	V_{CCr}	Power supply	Receiver power supply
3	SD	LVTTTL output	Receiver optical input level monitor
4	RD-	LVPECL output	Receiver data out bar
5	RD+	LVPECL output	Receiver data out
6	V_{CCt}	Power supply	Transmitter power supply
7	V_{EEt}	Ground	Transmitter signal ground
8	TDis	LVTTTL input	Transmitter disable
9	TD+	LVPECL input	Transmitter data in
10	TD-	LVPECL input	Transmitter data in bar
MS			Mounting studs
HL			Housing leads

Pin Configuration

V_{EEr} / V_{EEt}

Connect pins 1 and 7 to signal ground.

V_{CCr} / V_{CCt}

A 3.3 V DC power supply must be applied at pins 2 and 6. A recommended power supply filter network is given in the termination scheme. Locate power supply filtering directly at the transceiver power supply pins. Proper power supply filtering is essential for good EMI performance.

TD+ / TD-

Transmitter data LVPECL level inputs. Terminated and AC coupled internally.

RD- / RD+

Receiver data LVPECL level outputs. Biased and AC coupled internally.

TDis

A logical LVTTTL high input will disable the laser. To enable the laser, an LVTTTL low input must be applied. Leave pin unconnected if feature not required.

SD

LVTTTL output. A logical high output indicates normal optical input levels to the receiver. Low optical input levels at the receiver result in a low output. Signal Detect can be used to determine a definite optical link failure; break in fiber, unplugging of a connector, faulty laser source. However it is not a detection of a bad link due to data-related errors.

MS

Mounting studs are provided for transceiver mechanical attachment to the circuit board. They also provide an optional connection of the transceiver to the equipment chassis ground. The holes in the circuit board must be tied to chassis ground.

HL

Housing leads are provided for additional signal grounding. The holes in the circuit board must be included and tied to signal ground.

Description

Description

The Infineon Gigabit Ethernet multimode transceiver – part of Infineon Small Form Factor transceiver family – is based on and compliant to the Physical Medium Depend (PMD) sublayer and baseband medium, type 1000-Base-SX (short wavelength) as specified in IEEE 802.3 and Fibre Channel FC-PI Rev. 13 100-M5-SN-I, 100-M6-SN-I.

The appropriate fiber optic cable is 62.5 µm or 50 µm multimode fiber with LC™ connector.

Operating Range over each Optical Fiber Type

Fiber Type	Limit Values			Unit
	min.	typ.	max.	
62.5 micron MMF	0.5	2 to 300	400	meters
50.0 micron MMF	0.5	2 to 550	700	

The Infineon Gigabit Ethernet multimode transceiver is a single unit comprised of a transmitter, a receiver, and an LC™ receptacle. This design frees the customer from many alignment and PC board layout concerns.

This transceiver supports the LC™ connectorization concept. It is compatible with RJ-45 style backpanels for high end Data Com and Telecom applications while providing the advantages of fiber optic technology.

The module is designed for low cost SAN, LAN, WAN, Fibre Channel and Gigabit Ethernet applications. It can be used as the network end device interface in mainframes, workstations, servers, and storage devices, and in a broad range of network devices such as bridges, routers, hubs, and local and wide area switches.

This transceiver operates at 1.0625 and 1.25 Gbit/s from a single power supply (+3.3 V). The full differential data inputs and outputs are LVPECL compatible.

Functional Description of 2x5 Pin Row Transceiver

This transceiver is designed to transmit serial data via multimode cable.

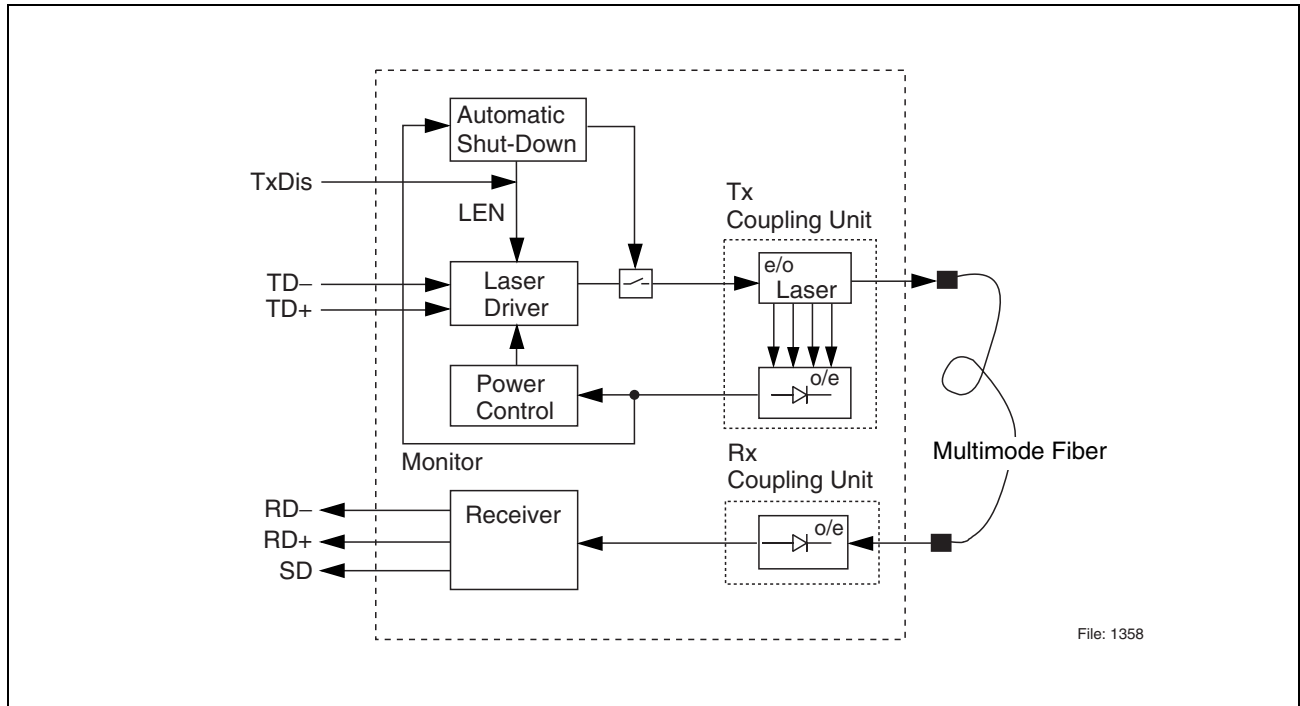

Figure 2 Functional Diagram

The receiver component converts the optical serial data into LVPECL compatible electrical data (RD+ and RD-). The Signal Detect (SD) shows whether an optical signal is present.

The transmitter converts LVPECL compatible electrical serial data (TD+ and TD-) into optical serial data. Data lines are differentially 100 Ω terminated.

The transmitter contains a laser driver circuit that drives the modulation and bias current of the laser diode. The currents are controlled by a power control circuit to guarantee constant output power of the laser over temperature and aging.

The power control uses the output of the monitor PIN diode (mechanically built into the laser coupling unit) as a controlling signal, to prevent the laser power from exceeding the operating limits.

Single fault condition is ensured by means of an integrated automatic shutdown circuit that disables the laser when it detects laser fault to guarantee the laser Eye Safety.

The transceiver contains a supervisory circuit to control the power supply. This circuit makes an internal reset signal whenever the supply voltage drops below the reset threshold. It keeps the reset signal active for at least 140 milliseconds after the voltage has risen above the reset threshold. During this time the laser is inactive.

A low signal on TxDis enables transmitter. If TxDis is high the transmitter is disabled.

Description

Regulatory Compliance

Feature	Standard	Comments
ESD: Electrostatic Discharge to the Electrical Pins	EIA/JESD22-A114-B (MIL-STD 883D Method 3015.7)	Class 1C
Immunity: Against Electrostatic Discharge (ESD) to the Duplex LC Receptacle	EN 61000-4-2 IEC 61000-4-2	Discharges ranging from ± 2 kV to ± 15 kV on the receptacle cause no damage to transceiver (under recommended conditions).
Immunity: Against Radio Frequency Electromagnetic Field	EN 61000-4-3 IEC 61000-4-3	With a field strength of 3 V/m, noise frequency ranges from 10 MHz to 2 GHz. No effect on transceiver performance between the specification limits.
Emission: Electromagnetic Interference (EMI)	FCC 47 CFR Part 15, Class B EN 55022 Class B CISPR 22	Noise frequency range: 30 MHz to 18 GHz

Technical Data
Absolute Maximum Ratings

Parameter	Symbol	Limit Values		Unit
		min.	max.	
Package Power Dissipation			0.6	W
Data Input Levels			$V_{CC}+0.5$	V
Differential Data Input Voltage Swing	$V_{IDpk-pk}$		5	V
Storage Ambient Temperature		-40	85	°C
Soldering Conditions, Temp/Time (MIL-STD 883C, Method 2003)			250/5.5	°C/s
V_{CC} max.			5.5	V
PECL Output Current			50	mA

Exceeding any one of these values may destroy the device immediately.

Recommended Operating Conditions

Parameter	Symbol	Limit Values			Unit
		min.	typ.	max.	
Ambient Temperature	T_{AMB}	0		70	°C
Power Supply Voltage	$V_{CC}-V_{EE}$	3.1	3.3	3.5	V

Transmitter

Data Input High Voltage DC/DC	$V_{IH}-V_{CC}$	-1165		-880	mV
Data Input Low Voltage DC/DC	$V_{IL}-V_{CC}$	-1810		-1475	mV
Differential Data Input Voltage Swing AC/AC	$V_{IDpk-pk}$	500		3200	mV

Receiver

Input Center Wavelength	λ_C	770		860	nm
-------------------------	-------------	-----	--	-----	----

The electro-optical characteristics described in the following tables are valid only for use under the recommended operating conditions.

Transmitter Electro-Optical Characteristics

Parameter	Symbol	Limit Values			Unit
		min.	typ.	max.	
Output Power (Average) ¹⁾	P_O	-9.5	-6	-4	dBm
Optical Modulation Amplitude ²⁾	OMA	156	450		μ W
Center Wavelength	λ_C	830	850	860	nm
Spectral Width (RMS)	σ_I			0.85	nm
Relative Intensity Noise	RIN			-116	dB/Hz
Extinction Ratio (Dynamic)	ER	9	13		dB
Total Tx Jitter	TJ		53	130	ps
Reset Threshold ³⁾	V_{TH}	2.2	2.7	2.99	V
Reset Time Out ³⁾	t_{RES}	140	240	560	ms
Rise Time, 20% - 80%	t_R			260	ps
Power Supply Current			65	75	mA

¹⁾ Into multimode fiber, 62.5 μ m or 50 μ m diameter.

²⁾ Fibre Channel PI Standard.

³⁾ Laser power is shut down if power supply is below V_{TH} and switched on if power supply is above V_{TH} after t_{RES} .

Receiver Electro-Optical Characteristics

Parameter	Symbol	Limit Values			Unit
		min.	typ.	max.	
Sensitivity (Average Power) ¹⁾	P_{IN}		-20	-17	dBm
Saturation (Average Power)	P_{SAT}	0			
Min. Optical Modulation Amplitude ²⁾	OMA		19	31	μ W
Stressed Receiver Sensitivity 50 μ m Fiber	S_{PIN}		24	55	μ W ³⁾
			-17	-13.5	dBm ⁴⁾
Stressed Receiver Sensitivity 62.5 μ m Fiber	S_{PIN}		32	67	μ W ³⁾
			-16	-12.5	dBm ⁴⁾
Signal Detect Assert Level ⁵⁾	P_{SDA}		-24	-18	dBm
Signal Detect Deassert Level ⁶⁾	P_{SDD}	-30	-27		dBm
Signal Detect Hysteresis	P_{SDA} $-P_{SDD}$		3		dB
Signal Detect Assert Time	t_{ASS}			100	μ s
Signal Detect Deassert Time	t_{DAS}			350	μ s
Receiver 3 dB Cut-off Frequency ²⁾			1.25	1.5	GHz
Receiver 10 dB Cut-off Frequency ²⁾			1.5	3	GHz
Differential Data Output Voltage Swing AC/AC ⁷⁾	$V_{ODpk-pk}$	500	700	1230	mV
Return Loss of Receiver	ORL	12			dB
Output Data Rise/Fall Time	t_R, t_F			260	ps
Supply Current ⁸⁾	I_{CCRx}		75	90	mA

¹⁾ Average optical power at which the BER is 1×10^{-12} . Measured with a 2^7-1 NRZ PRBS and ER = 9 dB.

²⁾ Fibre Channel PI Standard.

³⁾ Measured at the given Stressed Receiver Eye Closure Penalty and DCD component given in Fibre Channel PI Standard (2.03/2.18 dB & 40/80 ps).

⁴⁾ Measured according to IEEE 802.3

⁵⁾ An increase in optical power above the specified level will cause the Signal Detect output to switch from a low state to a high state.

⁶⁾ A decrease in optical power below the specified level will cause the Signal Detect to change from a high state to a low state.

⁷⁾ AC/AC for data. Load 50 Ω to GND or 100 Ω differential. For dynamic measurement a tolerance of 50 mV should be added.

⁸⁾ Supply current excluding Rx output load.

Eye Safety

This laser based multimode transceiver is a Class 1 product. It complies with IEC 60825-1 and FDA 21 CFR 1040.10 and 1040.11.

To meet laser safety requirements the transceiver shall be operated within the maximum operating limits.

Attention: All adjustments have been made at the factory prior to shipment of the devices. No maintenance or alteration to the device is required. Tampering with or modifying the performance of the device will result in voided product warranty.

Note: Failure to adhere to the above restrictions could result in a modification that is considered an act of “manufacturing”, and will require, under law, recertification of the modified product with the U.S. Food and Drug Administration (ref. 21 CFR 1040.10 (i)).

Laser Data

Wavelength	850 nm
Total output power (as defined by IEC: 7 mm aperture at 14 mm distance)	< 675 μW
Total output power (as defined by FDA: 7 mm aperture at 20 cm distance)	< 70 μW
Beam divergence	12°

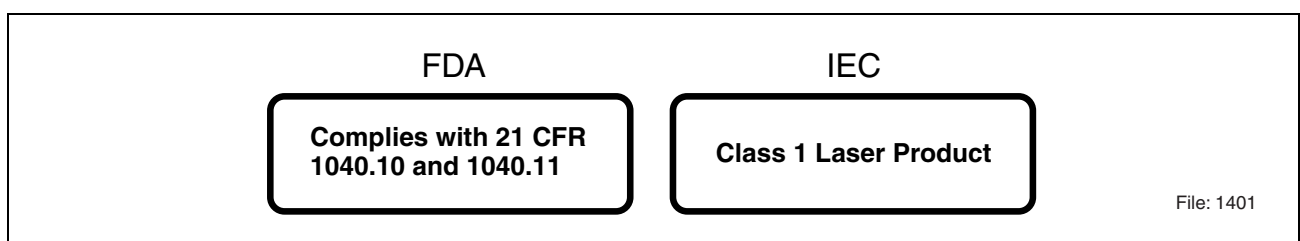

Figure 3 Required Labels

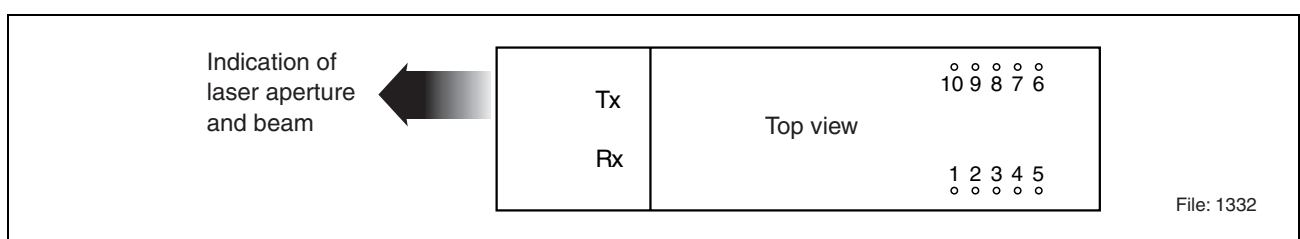

Figure 4 Laser Emission

Application Notes

Small Form Factor Pinning Comparison

The drawing below gives you a comparison between the different pinnings 2x5, 2x6, 2x10. Dimension for diameter and distance of additional pins is similar to the existing dimensions of the other pins.

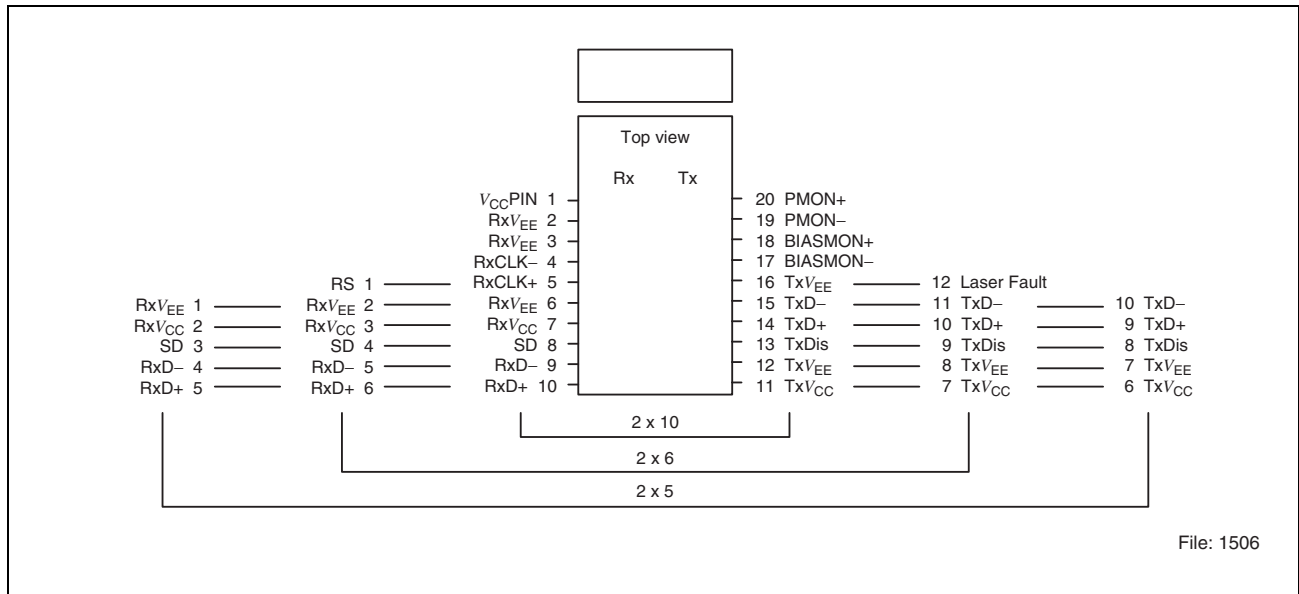

Figure 5

Pin Description

RS pin - The RS (Rate Select) is not connected.

LF pin - The LF pin (Laser Fault) is an LVTTTL output of the Laser Driver Supervisor Circuit. A Logic 1 level can be measured in case of a laser fault. It will not show a fault if the laser is being disabled using the TxDis input, since this is not a fault condition.

EMI-Recommendations

To avoid electromagnetic radiation exceeding the required limits please take note of the following recommendations.

When Gigabit switching components are found on a PCB (multiplexers, clock recoveries etc.) any opening of the chassis may produce radiation also at chassis slots other than that of the device itself. Thus every mechanical opening or aperture should be as small as possible.

On the board itself every data connection should be an impedance matched line (e.g. strip line, coplanar strip line). Data, Datanot should be routed symmetrically, vias should be avoided. A terminating resistor of 100 Ω should be placed at the end of each matched

Application Notes

line. An alternative termination can be provided with a 50 Ω resistor at each (D, Dn). In DC coupled systems a thevenin equivalent 50 Ω resistance can be achieved as follows: for 3.3 V: 125 Ω to V_{CC} and 82 Ω to V_{EE} , for 5 V: 82 Ω to V_{CC} and 125 Ω to V_{EE} at Data and Datanot. Please consider whether there is an internal termination inside an IC or a transceiver.

In certain cases signal GND is the most harmful source of radiation. Connecting chassis GND and signal GND at the plate/ bezel/ chassis rear e.g. by means of a fiber optic transceiver may result in a large amount of radiation. Even a capacitive coupling between signal GND and chassis may be harmful if it is too close to an opening or an aperture.

If a separation of signal GND and chassis GND is not planned, it is strongly recommended to provide a proper contact between signal GND and chassis GND at every location where possible. This concept is designed to avoid hotspots. Hotspots are places of highest radiation which could be generated if only a few connections between signal and chassis GND exist. Compensation currents would concentrate at these connections, causing radiation.

By use of Gigabit switching components in a design, the return path of the RF current must also be considered. Thus a split GND plane of Tx and Rx portion may result in severe EMI problems.

A recommendation is to connect the housing leads to signal GND. However, in certain applications it may improve EMI performance by connecting them to chassis GND.

The cutout should be sized so that all contact springs make good contact with the face plate.

Please consider that the PCB may behave like a waveguide. With an ϵ_r of 4, the wavelength of the harmonics inside the PCB will be half of that in free space. In this scenario even the smallest PCBs may have unexpected resonances.

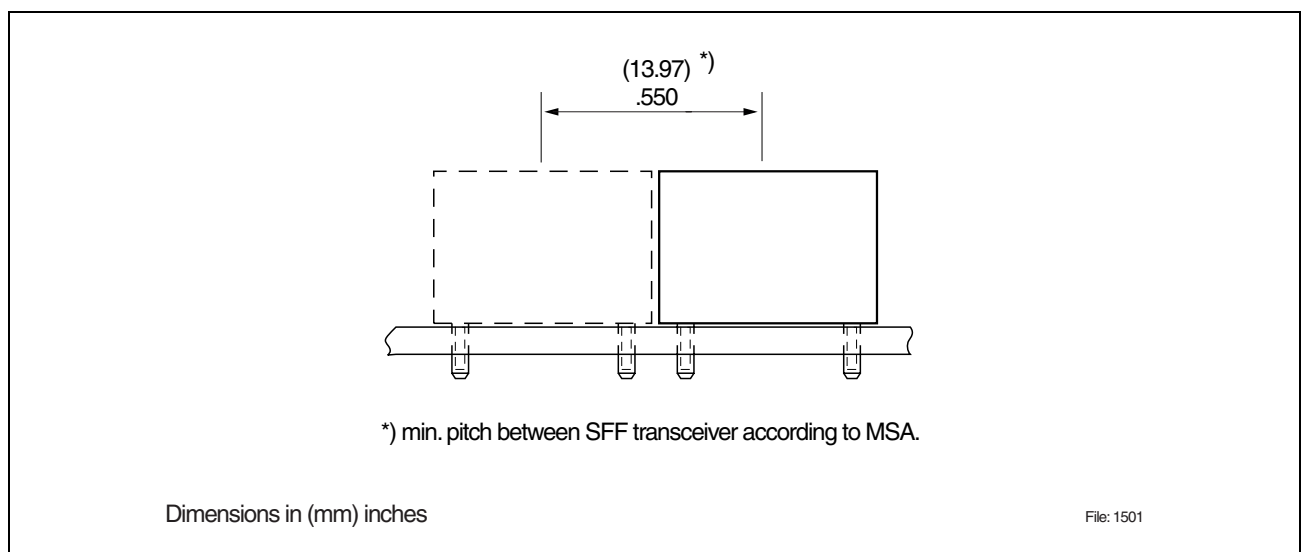
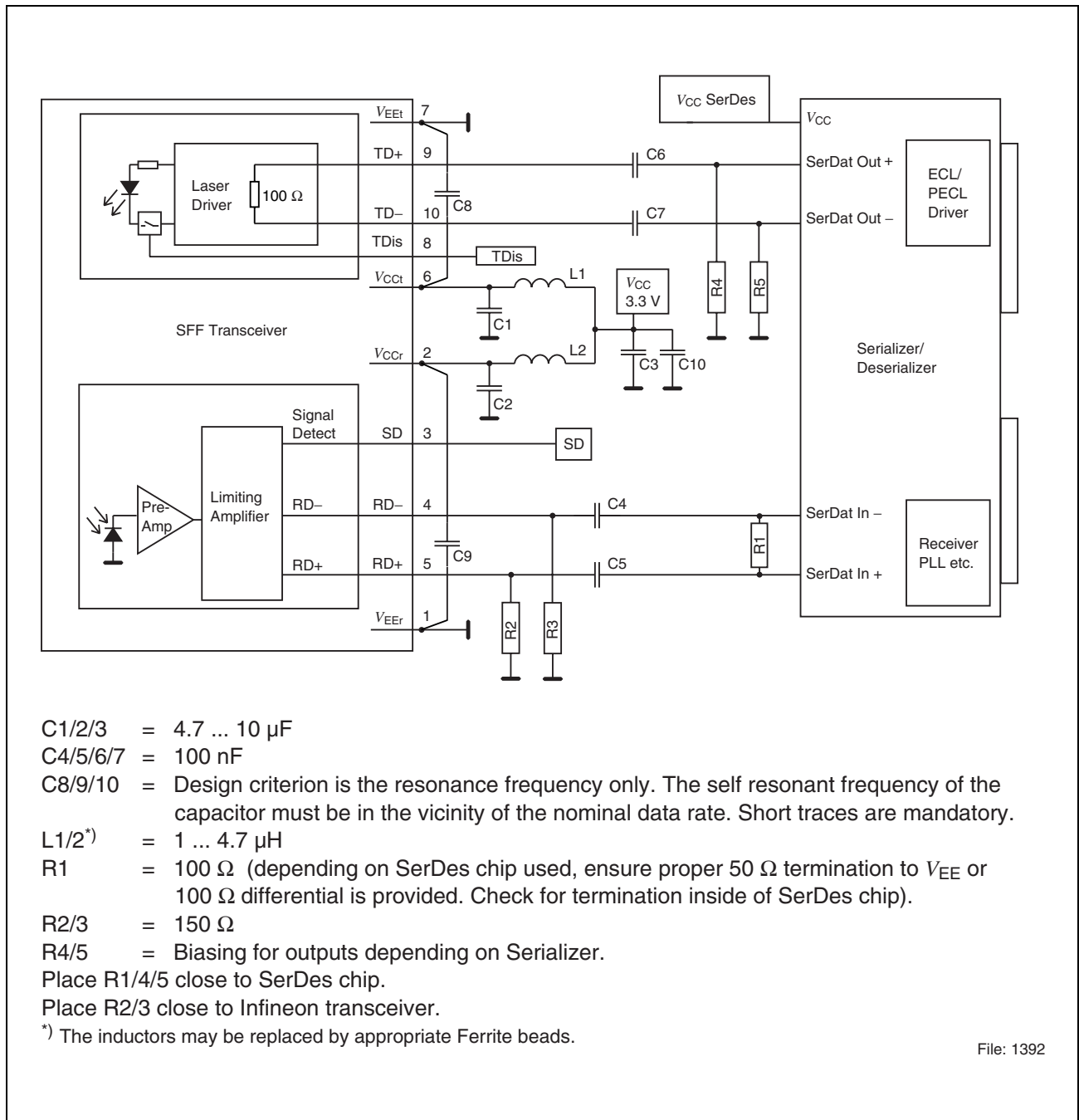

Figure 6 Transceiver Pitch

Recommended Termination Schemes

Recommended Termination Schemes

2x5 DC/DC Transceiver



File: 1392

Figure 7

Recommended Termination Schemes

2x5 AC/AC Transceiver

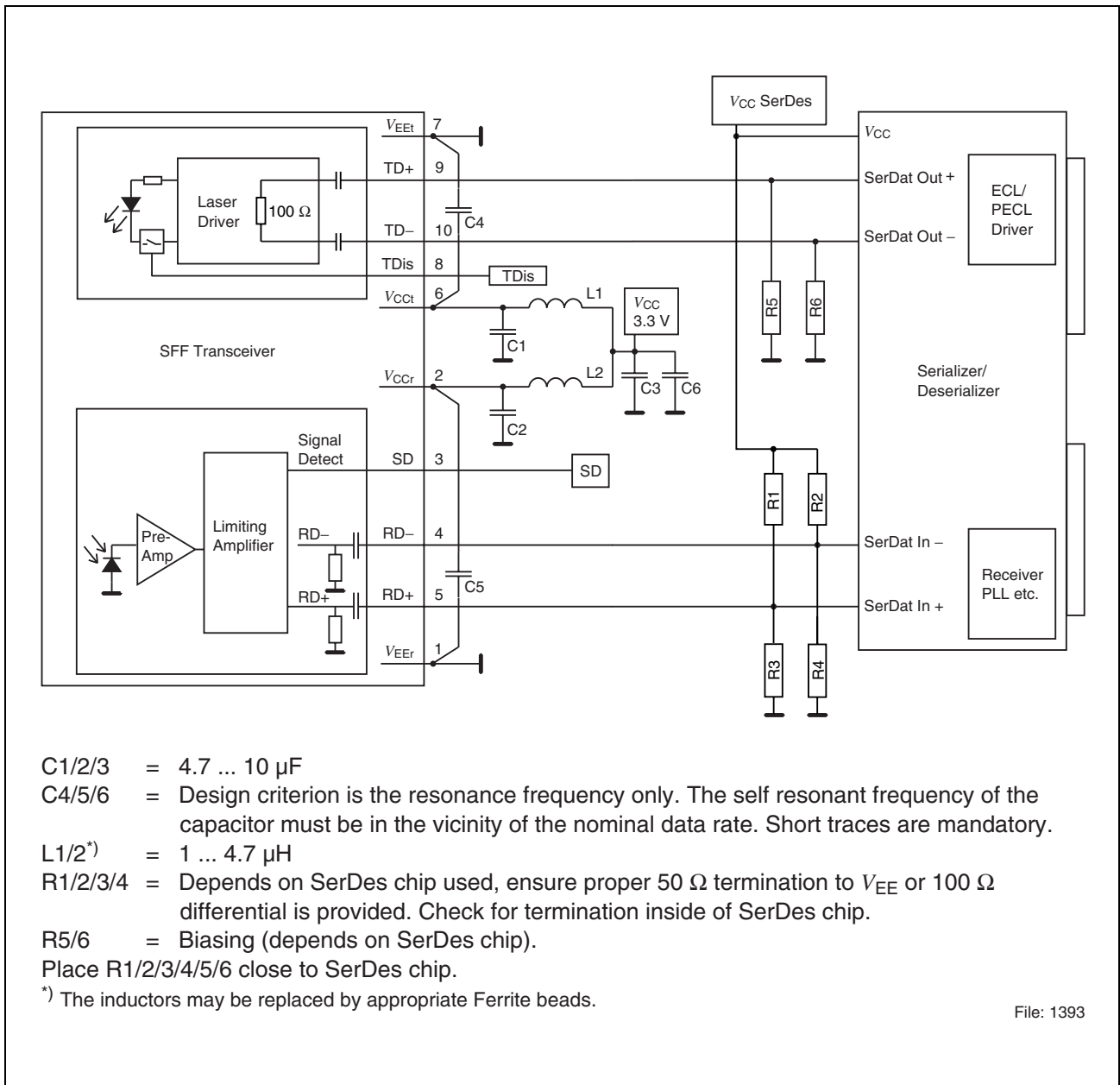

Figure 8

Package Outlines

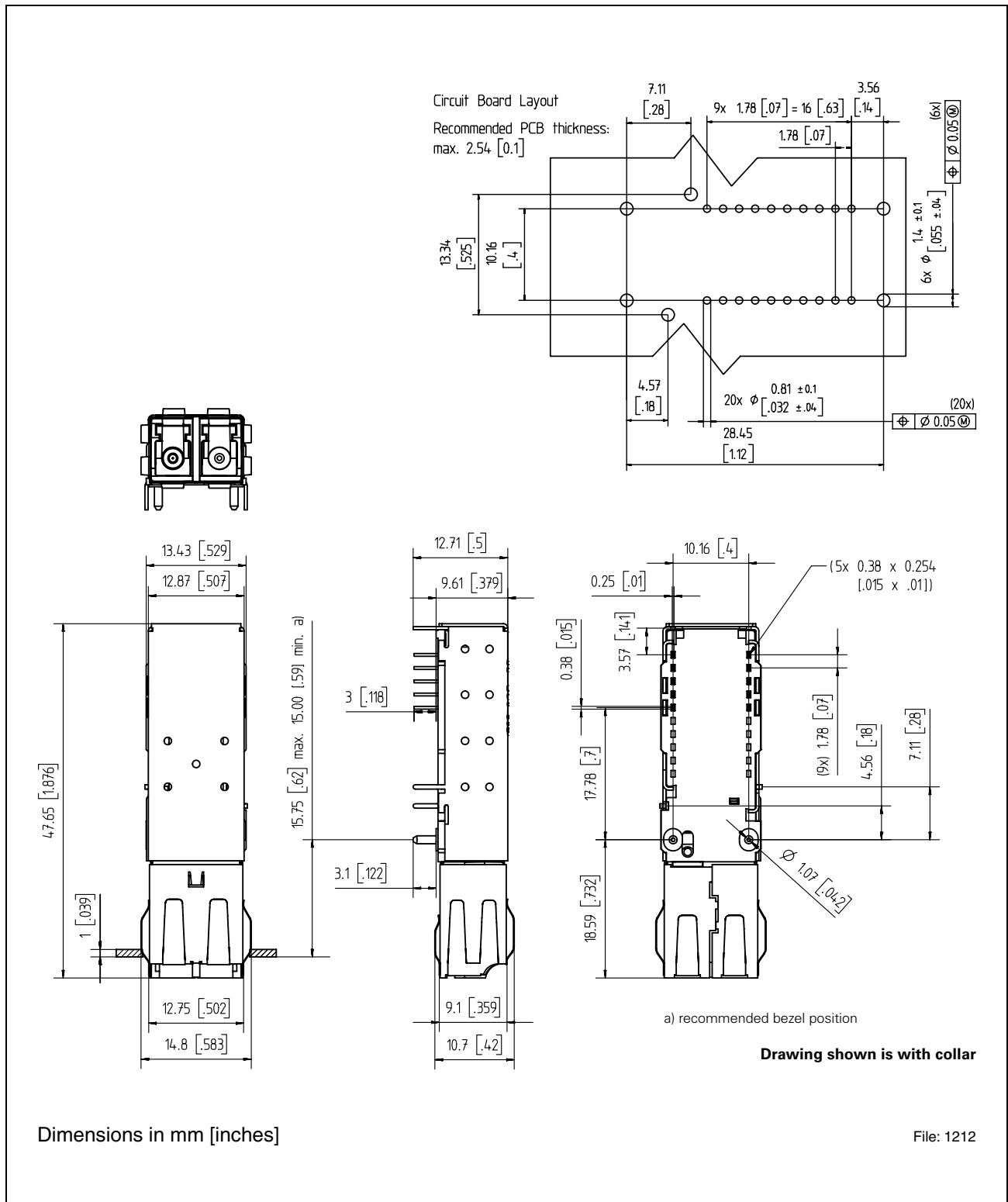

Figure 9

Revision History: 2003-01-22

DS1

Previous Version: 2002-03-22

Page	Subjects (major changes since last revision)
	Document completely revised; V23818-K305-L15 and V23818-K305-L55 added

For questions on technology, delivery and prices please contact the Infineon Technologies Offices in Germany or the Infineon Technologies Companies and Representatives worldwide: see our webpage at <http://www.infineon.com>.

Edition 2003-01-22**Published by Infineon Technologies AG,
St.-Martin-Strasse 53,
D-81541 München, Germany****© Infineon Technologies AG 2002.
All Rights Reserved.****Attention please!**

The information herein is given to describe certain components and shall not be considered as warranted characteristics.

Terms of delivery and rights to technical change reserved.

We hereby disclaim any and all warranties, including but not limited to warranties of non-infringement, regarding circuits, descriptions and charts stated herein.

Infineon Technologies is an approved CECC manufacturer.

Information

For further information on technology, delivery terms and conditions and prices please contact your nearest Infineon Technologies Office in Germany or our Infineon Technologies Representatives worldwide.

Warnings

Due to technical requirements components may contain dangerous substances. For information on the types in question please contact your nearest Infineon Technologies Office.

Infineon Technologies Components may only be used in life-support devices or systems with the express written approval of Infineon Technologies, if a failure of such components can reasonably be expected to cause the failure of that life-support device or system, or to affect the safety or effectiveness of that device or system. Life-support devices or systems are intended to be implanted in the human body, or to support and/or maintain and sustain and/or protect human life. If they fail, it is reasonable to assume that the health of the user or other persons may be endangered.