

Z87001/Z87L01

ROMLESS SPREAD SPECTRUM CORDLESS PHONE CONTROLLER

FEATURES

Device	ROM * (KWords)	RAM (Words)	I/O Lines	Package Information
Z87001	64	512	32	144-Pin QFP
Z87L01	64	512	32	144-Pin QFP

Note: *Maximum accessible external ROM

- Transceiver/Controller Chip Optimized for Implementation of 900 MHz Spread Spectrum Cordless Telephone
 - Adaptive Frequency Hopping
 - Transmit Power Control
 - Error Control Signaling
 - Handset Power Management
 - Support of 32 kbps ADPCM Speech Coding for High Voice Quality
- DSP Core Acts as Phone Controller
 - Zilog-Provided Embedded Transceiver Software to Control Transceiver Operation and Base Station-Handset Communications Protocol
 - User-Modifiable Software Governs Telephone Features

- Transceiver Circuitry Provides Primary Cordless Phone Communications Functions
 - Digital Downconversion with Automatic Frequency Control (AFC) Loop
 - FSK Demodulator
 - FSK Modulator
 - Symbol Synchronizer
 - Time Division Duplex (TDD) Transmit and Receive Buffers
- On-Chip A/D and D/A to Support 10.7 MHz IF Interface
- Up to 64 Kw of External Program Memory Accessible by the DSP Core
- Bus Interface to Z87010 ADPCM Processor
- Static CMOS for Low Power Consumption
- 3.0V to 3.6V, -20°C to +70°C, Z87L01
4.5V to 5.5V, -20°C to +70°C, Z87001
- 16.384 MHz Base Clock

GENERAL DESCRIPTION

The Z87001 /Z87L01 FHSS Cordless Telephone Transceiver/Controller is expressly designed to implement a 900 MHz frequency hopping spread spectrum cordless telephone compliant with US FCC regulations for unlicensed operation. The Z87001 and Z87L01 are distinct 5V and 3.3V versions, respectively, of the core device. For the sake of brevity, all subsequent references to the Z87001 in this document also apply to the Z87L01 unless specifically noted.

The Z87001 is the ROMless version of the Z87000 Spread Spectrum Controller IC. Specifically intended to facilitate user specific software development, the Z87001 can access up to 64 kwords of external program ROM.

The Z87001 supports a specific cordless phone system design that uses frequency hopping and digital modulation to provide extended range, high voice quality, and low system costs.

The Z87001 uses a Zilog 16-bit fixed-point two's complement static CMOS Digital Signal Processor core as the phone and RF section controller. The Z87001's DSP core processor further supports control of the RF section's frequency synthesizer for frequency hopping and the generation of the control messages needed to coordinate incorporation of the phone's handset and base station. Additional on-chip transceiver circuitry supports Frequency Shift Keying modulation/demodulation and multiplexing/demulti-

GENERAL DESCRIPTION (Continued)

plexing of the 32 kbps voice data and 4 kbps command data between handset and base station. The Z87001 provides thirty-two I/O pins, including four wake-up inputs and two CPU interrupt inputs. These programmable I/O pins allow a variety of user-determined phone features and board layout configurations. Additionally, the pins may be used so that phone features and interfaces are supported by an

optional microcontroller rather than by the Z87001's DSP core.

In combination with an RF section designed according to the system specifications, Zilog's Z87010/Z87L10 ADPCM Processor, a standard 8-bit PCM telephone codec and minimal additional phone circuitry, the Z87001 and its embedded software provide a total system solution.

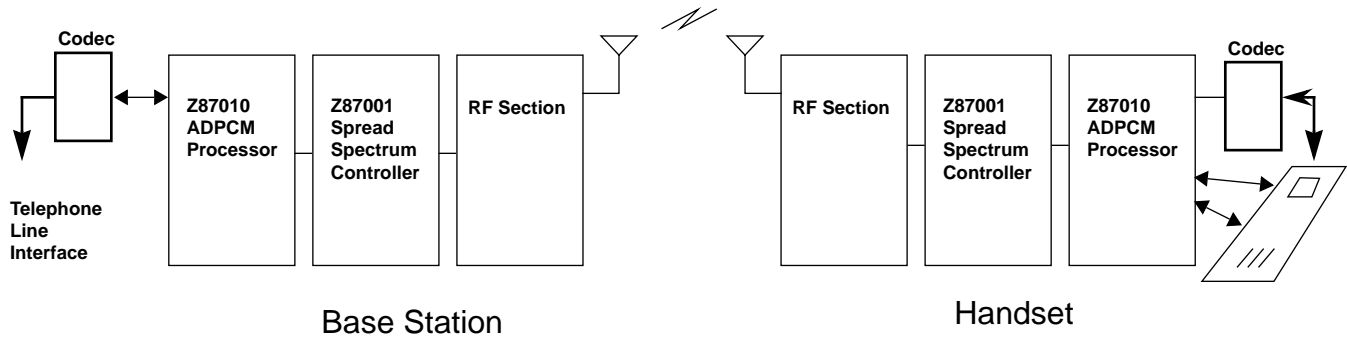

Figure 1. System Block Diagram of a Z87001/Z87010 Based Phone

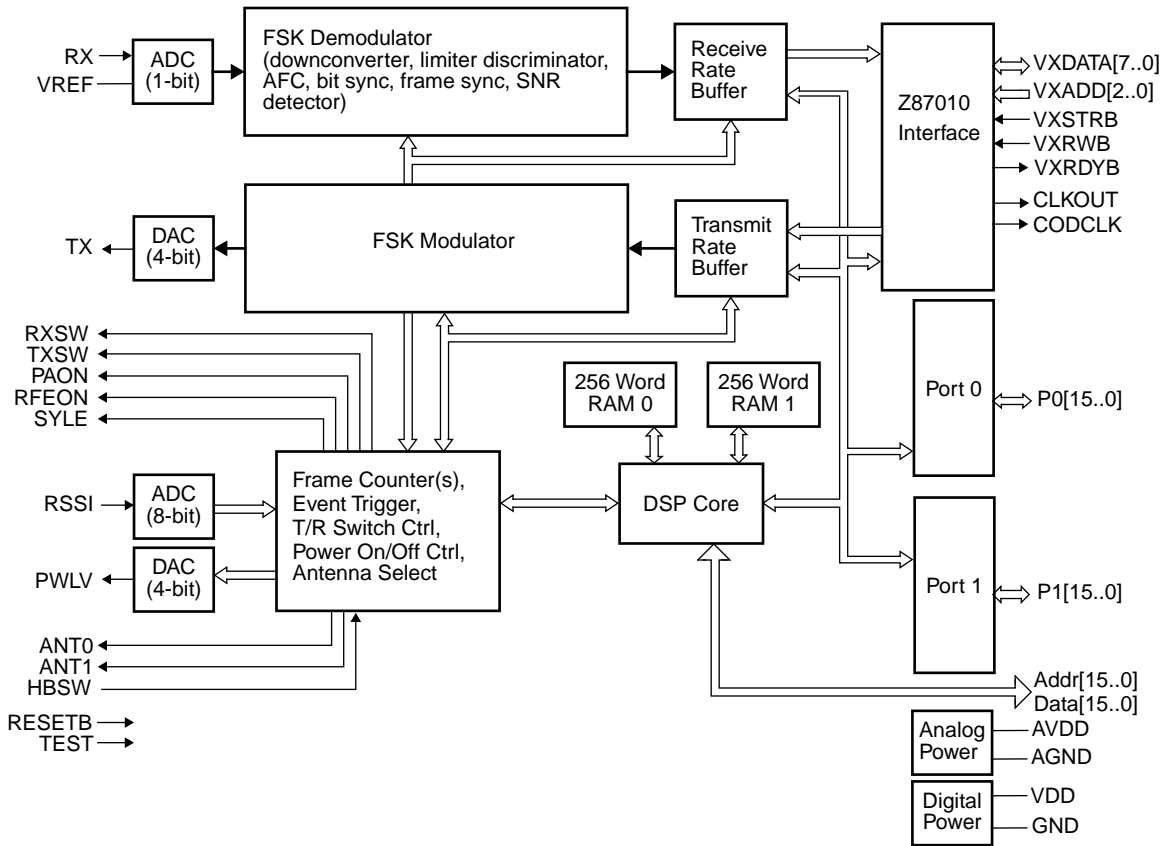

Figure 2. Z87001 Functional Block Diagram

PIN DESCRIPTION

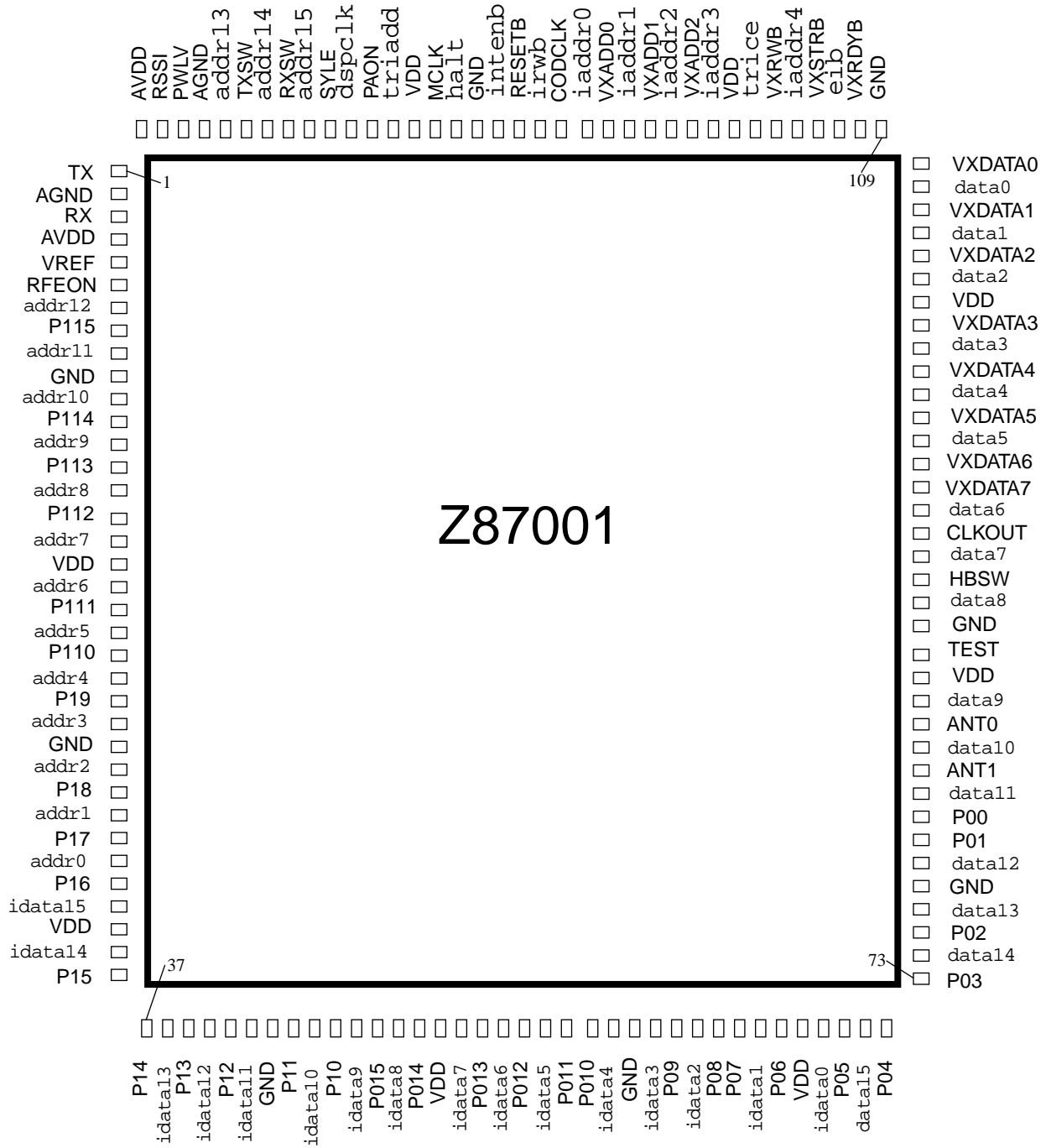

Figure 3. 144 Pin QFP Pin Configuration

Table 1. 144 Pin QFP Pin Configuration

No	Symbol	Function	Direction
1	TX	Analog transmit IF signal	Output
2,141	AGND	Analog ground	–
3	RX	Analog receive IF signal	Input
4,144	AV _{DD}	Analog power supply	–
5	VREF	Analog reference voltage for RX signal	–
6	RFEON	RF on/off control	Output
7,9,11,13,15,17,19, 21,23,25,27,29,31, 136,138,140	addr[15..0]	DSP core program address bus	Output
8,12,14,16,20,22,24, 28,30,32,36,37,39, 41,44,46	P1[15..0]	General-purpose I/O port 1	Input/Output
10,26,43,60,77,88, 109,128	GND	Digital ground	–
18,34,51,68,86,102, 116,131	V _{DD}	Digital power supply	–
33,35,38,40,42,45, 47,49,52,54,56,59, 61,63,66,69	idata[15..0]	DSP core internal data bus	Output
48,50,53,55,57,58, 62,64,65,67,70,72, 73,75,79,80	P0[15..0]	General-purpose I/O port 0	Input/Output
71,74,76,78,81,83, 85,89,91,93,96,98, 100,103,105,107	data[15..0]	DSP core program data bus	Input
82,84	ANT[1..0]	RF antenna diversity control	Output
87	TEST	Test mode select	Input
90	HBSW	Handset/base mode select	Input
92	CLKOUT	Clock, ADPCM processor (16.384 MHz)	Output
94,95,97,99,101, 104,106,108	VXDATA[7..0]	ADPCM processor data bus	Input
110	VXRDYB	ADPCM processor ready	Output
111	eib	External register data strobe	Output
112	VXSTRB	ADPCM processor data strobe	Input
113,117,119,121, 123	iaddr[4..0]	External register address bus	Output
114	VXRWB	ADPCM processor read/write control	Input
115	trice	ROMless mode select	Input
118,120,122	VXADD[2..0]	ADPCM processor address bus	Input
124	CODCLK	Clock to codec (2.048 MHz)	Output
125	irwb	External register read/write control	Output
126	/RESETB	Master reset	Input
127	intenb	Interrupt enable	Input

PIN DESCRIPTION (Continued)

Table 1. 144 Pin QFP Pin Configuration

No	Symbol	Function	Direction
129	halt	Halt/ single step control	Input
130	MCLK	Master clock (16.384 MHz)	Input
132	triadd	Program address bus enable	Input
133	PAON	RF transmit enable	Output
134	dspclk	DSP core clock	Output
135	SYLE	RF synthesizer load enable	Output
137	RXSW	Demodulator "on" indication	Output
139	TXSW	RF receive enable	Output
142	PWLV	RF transmit power level	Input
143	RSSI	RF receive signal strength indicator	Input

ABSOLUTE MAXIMUM RATINGS

Symbol	Parameter	Min	Max	Units
V_{DD} , AV_{DD}	DC Supply Voltage(1)	-0.5	7.0	V
V_{IN}	Input Voltage(2)	-0.5	$V_{DD} + 0.5$	V
V_{OUT}	Output Voltage(3)	-0.5	$V_{DD} + 0.5$	V
T_A	Operating Temperature	-20	+70	°C
T_{STG}	Storage Temperature	-65	+150	°C

Notes:

1. Voltage on all pins with respect to GND.
2. Voltage on all inputs WRT VDD
3. Voltage on all outputs WRT VDD

Stresses greater than those listed under Absolute Maximum Ratings may cause permanent damage to the device. This is a stress rating only; operation of the device at any condition above those indicated in the operational sections of these specifications is not implied. Exposure to absolute maximum rating conditions for extended period may affect device reliability.

STANDARD TEST CONDITIONS

The electrical characteristics listed below apply for the following standard test conditions, unless otherwise noted. All voltages are referenced to GND. Positive current flows into the referenced pins. Standard test conditions are as follows:

- $3.0V < V_{DD} < 3.6V$ (Z87L01)
- $4.5V < V_{DD} < 5.5V$ (Z87001)
- GND = 0V
- $T_A = -20$ to $+70$ °C

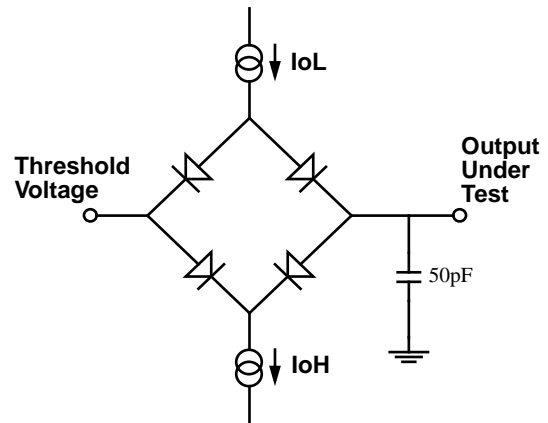

Figure 5. Test Load Diagram

RECOMMENDED OPERATING CONDITIONS

Table 3. 5V ± 0.5V Operation (Z87001)

Symbol	Parameter	Min	Max	Units
V_{DD}, AV_{DD}	Supply Voltage	4.5	5.5	V
V_{IH}	Input High Voltage	2.0	$V_{DD} + 0.3$	V
V_{IL}	Input Low Voltage	GND -0.3	0.8	V
I_{OH}	Output High Current		-2.0	mA
I_{OHICE}	Output High Current, ICE pins (1)		-0.5	mA
I_{OL1}	Output Low Current		4.0	mA
I_{OL2}	Output Low Current, GPIO (limited usage, 2)		12.0	mA
I_{OLICE}	Output Low Current, ICE pins (1)		0.5	mA
T_A	Operating Temperature	-20	+70	°C

Notes:

1. ICE pins are addr[15..0], iaddr[15..0], idata[15..0], eib and irwb
2. Maximum 3 pins total from P0[15..0] and P1[15..0]

Table 4. 3.3V ± 0.3V Operation (Z87L01)

Symbol	Parameter	Min	Max	Units
V_{DD}	Supply Voltage	3.0	3.6	V
V_{IH}	Input High Voltage	$0.7 V_{DD}$	$V_{DD} + 0.3$	V
V_{IL}	Input Low Voltage	GND -0.3	$0.1 V_{DD}$	V
I_{OH}	Output High Current		-1.0	mA
I_{OHICE}	Output High Current, ICE pins (1)		-0.5	mA
I_{OL1}	Output Low Current		2.0	mA
I_{OL2}	Output Low Current, Ports (limited usage, 2)		6.0	mA
I_{OLICE}	Output Low Current, ICE pins (1))		0.5	mA
T_A	Operating Temperature	-20	+70	°C

Notes:

1. ICE pins are addr[15..0], iaddr[15..0], idata[15..0], eib and irwb
2. Maximum 3 pins total from P0[15..0] and P1[15..0]

DC ELECTRICAL CHARACTERISTICS

Conditions for DC characteristics are corresponding operating conditions, and standard test conditions, unless otherwise specified.

Table 5. 5V ± 0.5V Operation (Z87001)

Symbol	Parameter	Test Condition	Min	Max	Units
V _{OH}	Output High Voltage	V _{DD} min, I _{OH} max	2.4		V
V _{OHICE}	Output High Voltage, ICE pins (1)	V _{DD} min, I _{OHICE} max	2.4		V
V _{OL1}	Output Low Voltage	V _{DD} min, I _{OL1} max		0.6	V
V _{OL2}	Output Low Voltage, GPIO (2)	V _{DD} min, I _{OL2} max		1.2	V
V _{OLICE}	Output Low Voltage, ICE pins (1)	V _{DD} min, I _{OLICE} max		0.4	V
I _L	Input Leakage	V _{IN} = 0V, V _{DD}	-2	2	μA
I _{CC}	Supply Current			80	mA
I _{CC2}	Standby Mode Current (3)			4	mA

Notes:

1. ICE pins are addr[15..0], iaddr[15..0], idata[15..0], eib and irwb
2. Maximum 3 pins total from P0[15..0] and P1[15..0]
3. 2.3 mA typical at 25°C, 5 volts.

Table 6. 3.3V ± 0.3V Operation (Z87L01)

Symbol	Parameter	Test Condition	Min	Max	Units
V _{OH}	Output High Voltage	V _{DD} min, I _{OH} max	1.6		V
V _{OHICE}	Output High Voltage, ICE pins (1)	V _{DD} min, I _{OHICE} max	1.6		V
V _{OL1}	Output Low Voltage	V _{DD} min, I _{OL1} max		0.4	V
V _{OL2}	Output Low Voltage, Ports(2)	V _{DD} min, I _{OL2} max		1.2	V
V _{OLICE}	Output Low Voltage, ICE pins (1)	V _{DD} min, I _{OLICE} max		0.4	V
I _L	Input Leakage	V _{IN} = 0V, V _{DD}	-2	2	μA
I _{CC}	Supply Current			55	mA
I _{CC2}	Standby Mode Current(2)		1.4		mA

Notes:

1. ICE pins are addr[15..0], iaddr[15..0], idata[15..0], eib and irwb
2. Maximum 3 pins total from P0[15..0] and P1[15..0]
3. 1.6 mA typical at 25°C, 3.3 volts.

ANALOG CHARACTERISTICS

Table 7. 1-Bit ADC (Temperature: -20/+70°C)

Parameter	Minimum	Typical	Maximum	Units
Resolution	-	1	-	bit
Power dissipation	0.54 (70°C)	1.0 (40°C)	2.75 (-20°C)	mW
Power dissipation, Stop mode	0.06 (70°C)	0.2 (40°C)	1.1 (-20°C)	mW
Sample frequency	-	8.192	-	MHz
Sample window(1)	29	31	33	ns
Bandwidth	-	60	-	MHz
Supply Range(=AV _{DD})				
Z87L01	3.0		3.6	V
Z87001	4.5		5.5	V
Acquisition time	2	3	8	ns
Settling time	8	10	18	ns
Conversion time	4	6	18	ns
Aperture delay	2	3	8.5	ns
Aperture uncertainty(2)	-	-	0.5	ns
Input voltage range (p-p)	800	1000	1200	mV
Reference voltage				
Z87L01	1.7 (AV _{DD} = 3V)	1.9 (AV _{DD} = 3.3V)	2.1 (AV _{DD} = 3.6V)	V
Z87001	2.7 (AV _{DD} =4.5V)	3.0 (AV _{DD} = 5V)	3.3 (AV _{DD} = 5.5V)	V
Input resistance	10	18	25	KOhm
Input capacitance	-	10	-	pF

Notes:

Window of time while input signal is applied to sampling capacitor; see next figure.

Uncertainty in sampling time due to random variations such as thermal noise.

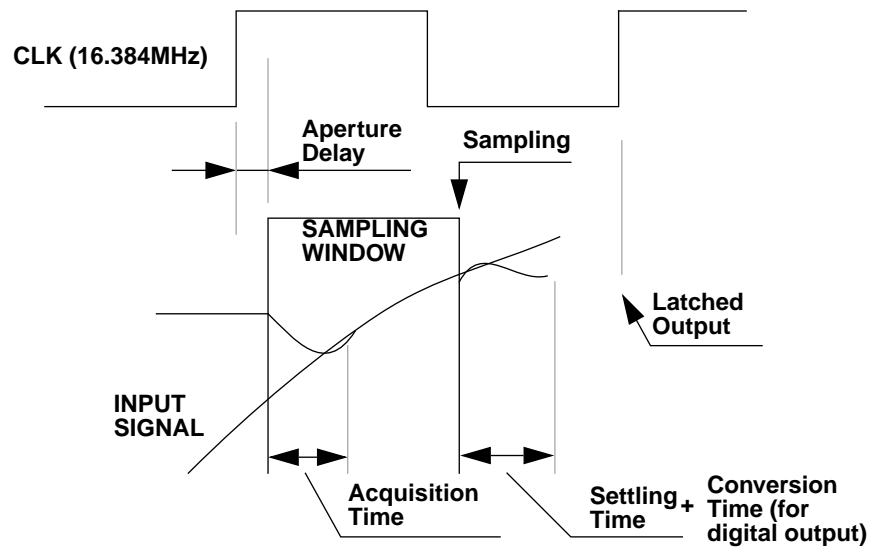

Figure 6. 1-Bit ADC Definition of Terms

Table 8. 8-bit ADC (Temperature -20/+70°C)

Parameter	Minimum	Typical	Maximum	Units
Resolution	-	6	-	bit
Integral non-linearity	-	0.5	1	LSB
Differential non-linearity	-	-	0.5	LSB
Power Dissipation (peak)		35	70	mW
Sample window	5	-	120	ns
Bandwidth	-	-	2	MspS
Supply Range (=AV _{DD})				
Z87L01	3.0	3.3	3.6	V
Z87001	4.5	5.0	5.5	V
Input voltage range		0-AV _{DD}		V
Conversion time	0.5	-	-	μs
Aperture delay	2	3	8.5	ns
Aperture uncertainty	-	-	1	ns
Input resistance	-	25	-	Kohm
Input capacitance	-	10	-	pF

Notes:

1. 8-bit ADC only tested for 6-bit resolution.

Table 9. 4-bit DAC (Temperature: -20/+70°C)

Parameter	Minimum	Typical	Maximum	Units
Resolution	-	4	-	bit
Integral non-linearity	-	0.25	0.5	LSB
Differential non-linearity	-	0.25	1	LSB
Settling time (1/2 LSB)	-	-	22.5	ns
Zero error at 25°C	-	1	2	mV
Conversion time (input change to output change)	14	19	76	ns
Power dissipation, 25 pF load	1.2 (70°C)	20 (40°C)	24.1 (-20°C)	mW
Power dissipation, 25 pF load, Stop mode	0.18 (70°C)	1.0 (40°C)	1.1 (-20°C)	mW
Conversion time (input change to output change)	14.5	19.1	75.8	ns
Rise time (full swing)	11	15	71	ns
Output slew rate	8	67	96	V/μs
Output voltage range	-	0.2 AV _{DD} to 0.6AV _{DD}	-	V
Supply Range (=AV _{DD})				
Z87L01	3.0	3.3	3.6	V
Z87001	4.5	5.0	5.5	V
Output load resistance		330		Ohm
Output load capacitance	-	25	-	pF

INPUT/OUTPUT PIN CHARACTERISTICS

All digital pins (all pins except V_{DD} , AV_{DD} , GND, AGND, V_{REF} , RX, TX, RSSI and PWLV) have an internal capacitance of 5 pF.

The RX analog input pin has an input capacitance of 10 pF.

The RSSI analog input pin has an input capacitance of 10 pF.

AC ELECTRICAL CHARACTERISTICS**Clocks, Reset and RF Interface****Table 10. Clocks, Reset and RF Interface**

No.	Symbol	Parameter	Min	Max	Units
1	TpC	MCLK input clock period (1)	61	61	ns
2	TwC	MCLK input clock pulse width	20	40	ns
3	TrC, TfC	MCLK input clock rise/fall time		15	ns
4	TrCC, TfCC	CLKOUT output clock rise/fall time	2	6	ns
5	TrCO, TfCO	CODCLK output clock rise/fall time	2	6	ns
6	TwR	RESETB input low width	18		TpC
7	TrRF, TfRF	RF output controls rise/fall time (2)	2	6	ns

Notes:

1. MCLK is 16.384 MHz \pm 25 ppm
2. RF Controls are PAON, TXSW, RFEON, SYLE.

ADPCM Processor Interface

The Z87001 is a peripheral device for the ADPCM Processor. The interface from the Z87001 perspective is composed of an input address bus, a bidirectional data bus, strobe and read/write input control signals and a ready/wait output control signal.

READ CYCLES refer to data transfers from the Z87001 to the ADPCM Processor.

WRITE CYCLES refer to data transfers from the ADPCM Processor to the Z87001.

Table 11. Read Cycles

Signal Name	Function	Direction
VXADD[2..0]	Address Bus	ADPCM Proc. to Z87001
VXDATA[7..0]	Data Bus	Bidirectional
VXSTRB	Strobe Control Signal	ADPCM Proc. to Z87001
VXRWB	Read/Write Control Signal	ADPCM Proc. to Z87001
VXRDYB	Ready Control Signal	Z87001 to ADPCM Proc.

Table 12. Write Cycles

No.	Symbol	Parameter	Min	Max	Units
8	TsAS	Address, Read/Write setup time before Strobe falls	10		ns
9	ThSA	Address, Read/Write hold time after Strobe rises	3		ns
10	TaDrS	Data read access time after Strobe falls		30 (1)	ns
11	ThDrS	Data read hold time after Strobe rises	8.5	40 (2)	ns
12	TwS	Strobe pulse width	20		
13	TsDwS	Data write setup time before Strobe rises	10		ns
14	ThDwS	Data write hold time after Strobe rises	3		ns
15	TaDrRY	Data read valid before Ready falls	22		ns
16	TdSRY	Strobe high after Ready falls	0		ns

Notes:

1. Requires wait state on ADPCM Processor read cycles
2. Requires no write cycle directly following read cycle on ADPCM Processor

AC TIMING DIAGRAMS

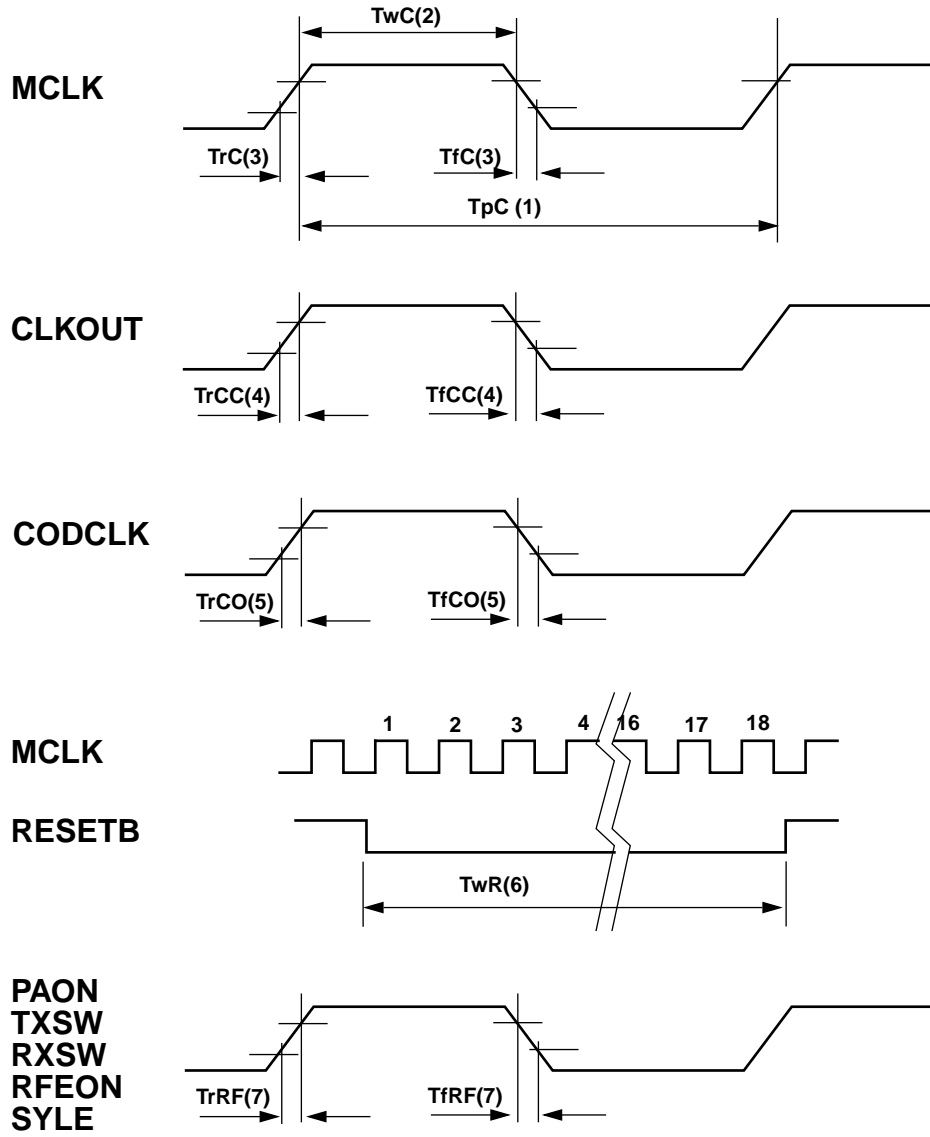

Figure 7. Transceiver Output Signal

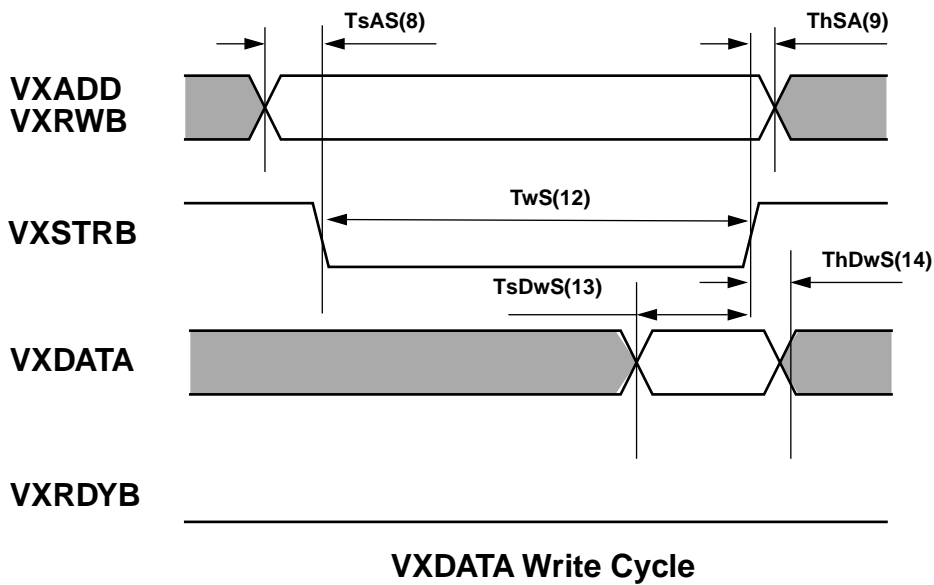
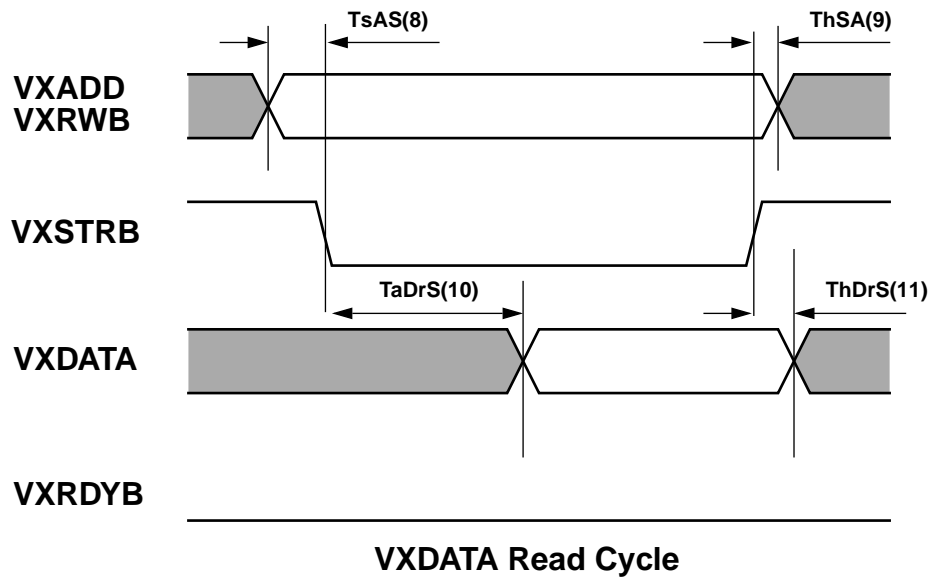

Figure 8. Read/Write Cycle Timings

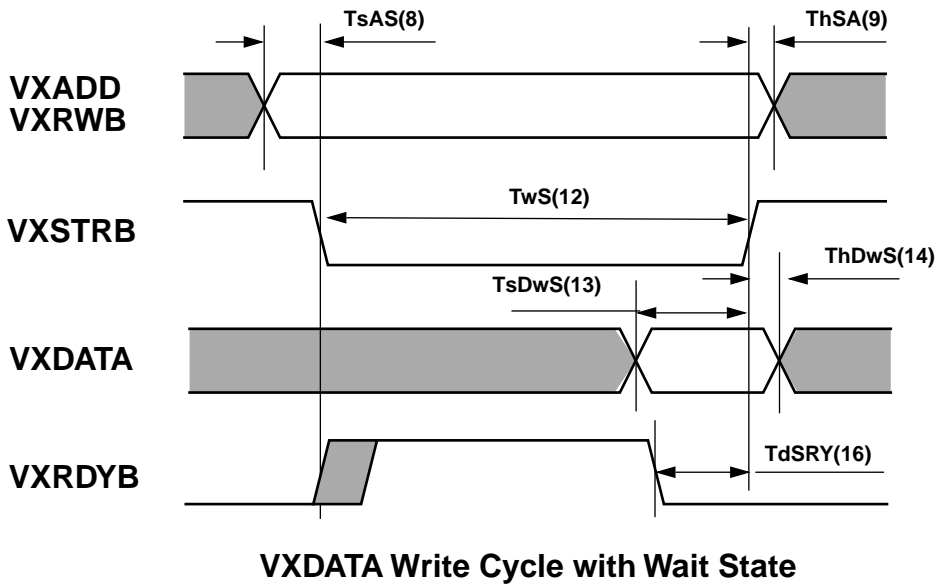
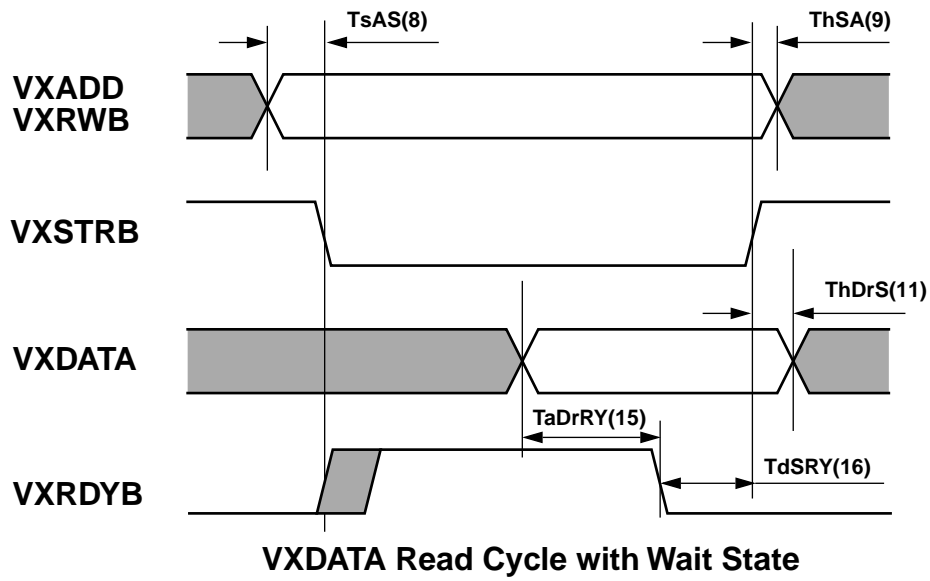

Figure 9. Read/Write Cycle Timing with Wait State

PIN FUNCTIONS

V_{DD}. Digital power supply.

GND. Digital ground.

AV_{DD}. Analog power supply.

AGND. Analog ground.

V_{REF} (analog reference). This signal is the reference voltage used by the high speed analog comparator to sample the RX input signal.

RX (analog input). This is the RX IF receive signal from the RF module, input to the analog comparator and FSK demodulator. It is internally biased to the V_{REF} DC voltage. The IF signal from the RF module should be AC coupled to the RX pin.

TX (analog output). This is the IF transmit signal to the RF module, output from the FSK modulator and transmit 4-bit D/A converter.

RXSW (output; active high or low programmable). This pin reflects the programming of the demodulator turn-on time.

TXSW (output; active high or low programmable). Control for the receive switch on the RF module. Active during receive periods.

PAON (output; active high or low programmable). Control for the transmit switch on the RF module. Active during transmit periods.

RFEON (output; active high or low programmable). On/off control for the RF module. Active (on) during wake periods. Inactive (off) during sleep periods on the handset.

RSSI (analog input). Receive signal strength indicator from RF module, input to the RSSI 8-bit ADC.

PWLV (analog output). Power level control for RF module, output from the transmit power 4-bit DAC.

SYLE (output). RF synthesizer load enable: latches new frequency hopping control word of external RF synthesizer. Programmable polarity.

ANT[1..0] (output). Control for optional antenna diversity on the RF module.

MCLK (input). Master clock input.

CLKOUT (output). Clock output for external ADPCM processor.

CODCLK (output). Clock output for external voice codec.

/RESETB (input, active low). Reset signal.

VXADD[2..0] (input). Address bus controlled by external ADPCM processor. The Z87001 acts as peripheral of the Z87010 ADPCM processor.

VXDATA[7..0](input/output). Read/write data bus controlled by external Z87010 ADPCM processor.

VXSTRB (input). Data strobe signal for the VXDATA bus, controlled by external Z87010.

VXRWB (input). Read/write control for the VXDATA bus, controlled by external Z87010.

VXRDYB (output, active low). Ready control for the VXDATA bus. This signal is driven high (de-asserted) by the Z87001 to insert wait states in the Z87010 ADPCM processor accesses.

TEST (input, active high). Main test mode control. Must be set to GND.

HBSW (input with internal pull-up). Control for handset/base configuration. Must be driven high or not connected for handset, low for base.

P0[15..0] (input/output). General-purpose I/O port. Direction is bit-programmable. Pins P0[3..0], when configured in input mode, can also be individually programmed as wake-up pins for the Z87001 (wake-up active low; signal internally debounced and synchronized to the bit clock).

P0 0	WAKEUP0
P0 1	WAKEUP1
P0 2	WAKEUP2
P0 3	WAKEUP3

P1[15..0] (input/output). General-purpose I/O port. Direction is bit-programmable. Pins P114 and P115, when configured in input mode, also behave as individually maskable interrupt pins for the core processor (positive edge-triggered).

P1 14	INT0
P1 15	INT2

FUNCTIONAL DESCRIPTION

The functional partitioning of the Z87001 is shown in Figure 2. The chip consists of a receiver, a transmitter, and several additional functional blocks. The receiver consists of the following blocks:

- Receive 1-bit ADC
- Demodulator, including:
 - IF Downconverter
 - AFC (Automatic Frequency Control)
 - Limiter-Discriminator
 - Matched Filter
 - Bit Synchronizer
 - Bit Inversion
 - Frame Synchronizer (unique word detector)
 - SNR Detector
- Receive Frame Timing Counter
- Receive Buffer and Voice Interface

The Transmitter Consists of the Following Blocks:

- Transmit Buffer and Voice Interface
- Transmit Frame Timing Counter (used on base station only)
- Modulator, including:
 - NCO
 - Bit Inversion

- Transmit 4-Bit DAC
- In Addition, there are the following Shared Blocks.
- Event Trigger Block, Controlling:
 - Transmit/Receive Switch
 - Power On/Off Switches (Modulator, Demodulator, RF Module)
 - Antenna Switch Control (used on Base Station only for Antenna Diversity)
 - 4-Bit DAC for Setting Transmit Power Level
 - 8-Bit ADC for Sampling the Received Signal Strength Indicator (RSSI)
 - DSP Core Processor
 - Two 16-Bit General-Purpose I/O Ports
 - Z87010 ADPCM Processor Interface

Basic Operation

The transmitter and receiver operate in time-division duplex (TDD): handset and base station transmit and receive alternately. The TDD duty cycle lasts 4 ms and consists of the following events:

- At the beginning of the cycle, the frequency is changed (hopping)
- The base station transmits a frame of 144 bits while the handset receives
- The handset then transmits a frame of 148 bits while the base receives.

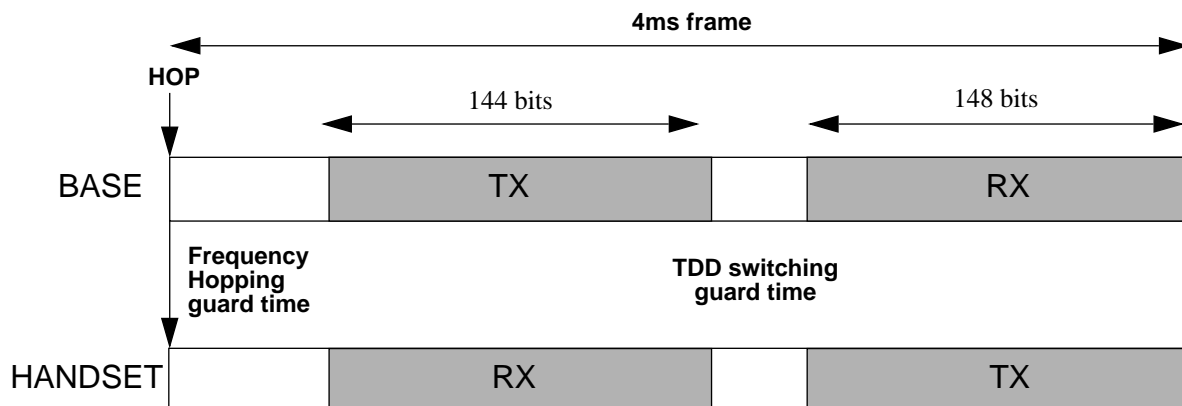

Figure 1. Basic Time Duplex Timing

Receive 1-Bit ADC

The incoming receive signal at the RX analog input pin is sampled by a 1-bit analog-to-digital converter at 8.192 MHz.

The receive signal is FSK-modulated (Frequency Shift Keying) with a carrier frequency of 10.7 MHz (Intermediate Frequency, or IF). The instantaneous frequency varies between 10.7 MHz plus or minus 32.58 kHz. Since the data rate is 93.09 kbps, there are 88 samples per data bit. This oversampled data is further processed by the demodulator to retrieve the baseband information.

The 1-bit converter is implemented with a fast comparator, which determines whether the RX signal is larger or smaller than a reference signal (VREF). The Z87001 internally generates the DC level of both VREF and RX input pins. The received signal at 10.7 MHz should thus be AC coupled to the RX pin via a coupling capacitor. To ensure accurate operation of the converter, the user should also attach to the VREF pin a network whose impedance matches the DC impedance seen by the RX pin.

Demodulator

The demodulator includes a two-stage IF downconverter that brings the sampled receive signal to baseband.

The narrow-band 10.7 MHz receive signal, sampled at 8.192 MHz by the 1-bit ADC, provides a 2.508 MHz useful image. The first local oscillator used to downconvert this IF signal is obtained from a Numerically Controlled Oscillator (NCO) internal to the Z87001, at the nominal frequency of 460 kHz. The resulting signal is thus at 2.048 MHz (= 2.508 MHz - 460 kHz). A second downconversion by a 2.048 MHz signal brings the receive signal to baseband.

The exact frequency of the 460 kHz NCO is slightly adjusted by the Automatic Frequency Control (AFC) loop for exact downconversion of the end signal to the zero frequency. The AFC circuit detects any DC component in the output of the limiter-discriminator (see below) when receiving a known sequence of data (preamble). This DC component is called the "frequency bias". The bias estimate out of the AFC can be read by the DSP processor on every frame and subsequently filtered. The processor then adds or subtracts this filtered bias to/from the NCO control word to correct the NCO frequency output.

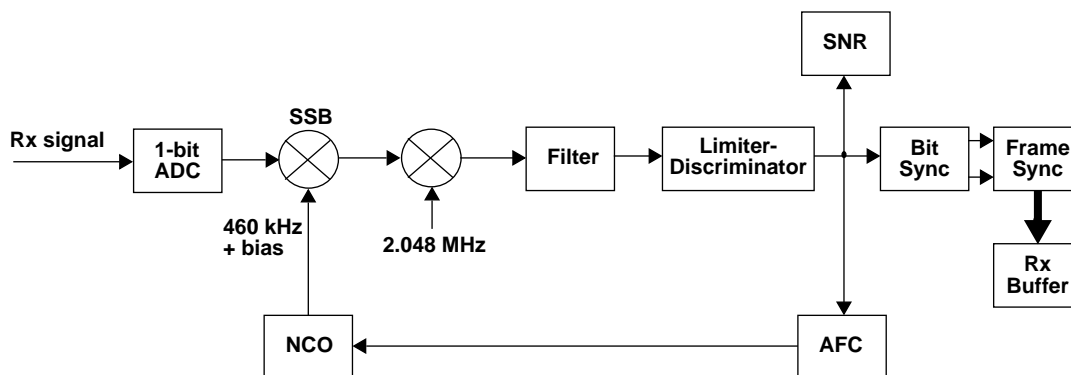

Figure 2. Demodulator Block Diagram

The main element of the demodulator is its limiter-discriminator. The limiter-discriminator detects the frequency variations (ideally up to ± 32.58 kHz) and converts them to "0" or "1" information bits. First, the data is processed through low-pass filters to eliminate high frequency spurious components introduced by the 1-bit ADC. The resulting signal is then differentiated and fed to a matched filter. In the matched filter, an integrate-and-dump operation is performed to extract the digital information from its background noise.

The symbol clock is provided by the bit synchronizer. The bit synchronizer circuit detects 0-to-1 and 1-to-0 transitions

in the incoming data stream in order to synchronize a digital phase-lock loop (DPLL). The PLL output is the recovered bit clock, used to time the receiver on the base station, and both receiver and transmitter on the handset.

To ensure enough transitions in the voice data stream, a pseudo-random bit inversion operation is performed on the outgoing voice data. The inversion is then reversed on the demodulated data.

Since the data is packed in frames sent alternately from base and handset every 4 ms (TDD), additional synchronization means are necessary. This is realized in a frame

FUNCTIONAL DESCRIPTION (Continued)

synchronizer, based on detection of a “unique word” following the preamble.

The receiver also features a signal-to-noise ratio detector, which allows the DSP software to detect noisy channels and eliminate them from the frequency hopping cycle. The SNR information is also used by the Z87001 software as a measure the current range between handset and base station. This information allows the adaptive power control algorithm to provide sufficient output power to the RF transmitter.

Receive Frame Counter

The receive frame counter is responsible to keep track of time within the frame. It is initialized by the frame synchronizer logic on detection of the unique word. It is then clocked by the recovered bit clock from the bit synchronizer.

On the base station, the receive frame counter is used as time base for the receiver. On the handset, it is used as time base for both receiver and transmitter.

Receive Rate Buffer and Voice Interface

The voice signal is generated at the fixed rate of 32 kips by the Z87010 processor, and transmitted/received in bursts of 93.09 kips across the air. Data buffers in the transmitter and receiver are thus necessary to absorb the rate differences over time. These buffers are called “rate buffers”. They can store up to 144 data bits and are organized as an array of 36 4-bit nibbles.

The receive rate buffer stores the received data from the demodulator. Incoming bits are arranged in 4-bit nibbles and transferred to successive locations of the rate buffer. When the last location is reached, transfers resume from the beginning (circular buffer). The system design guarantees that no buffer overrun nor enduring can occur.

The receive rate buffer can be read by the DSP core processor of the Z87001 or by the Z87010 chip. On the Z87001 side, the buffer can be read as a random-access memory: the processor writes the nibble address in an address register and reads the 4-bit data from a data register. On the Z87010 side, a voice processor interface logic handles the addressing to automatically present the successive voice nibbles to the Z87010 in the order they were received.

Transmit Rate Buffer and Voice Interface

The transmit rate buffer stores the data to be modulated. The data is sourced from the Z87010 or the Z87001 core processor. As for the receive rate buffer, the Z87010 sees a unique pipe to write to, while the Z87001 DSP core accesses the rate buffer as random-access memory. The modulator reads from the rate buffer as from a circular buffer.

Transmit Frame Timing Counter

On the handset, transmission does not start until the receiver has synchronized itself to the signal received from the base station. The transmission timing is based on the recovered clock. No additional counter is necessary.

On the base station, the situation is different. Transmission timing is based on a local clock, while the reception’s timing is based on the clock recovered from the incoming received signal. Two counters, respectively clocked by local and recovered clocks, are necessary to track the transmit and receive signals.

Note that the receive clock on the base station tracks the handset’s transmit clock, which is also the handset’s receive clock and tracks the transmit clock of the base station. As a result, receive and transmit clocks of the base station have exactly the same frequency; only their phases differ.

Modulator

The modulator consists of a numerically controlled oscillator (NCO) which generates an FSK (Frequency Shift Keying) signal at the carrier frequency of 2.508 MHz. The carrier frequency is shifted plus or minus 32.58 kHz for a “1” or a “0” data bit. To facilitate conformance to FCC regulations, the transitions from “1” to “0” or vice-versa are smoothed in order to decrease the amplitude of the side lobes of the transmit signal. In practice, the jump from one frequency to the next is performed in several smaller steps.

The carrier frequency is adjustable by the DSP core processor in order to provide additional frequency adjustment between base and handset. This is provided in case of a frequency offset too large for possible correction by the AFC.

The modulator also includes bit inversion logic as discussed in the receiver section.

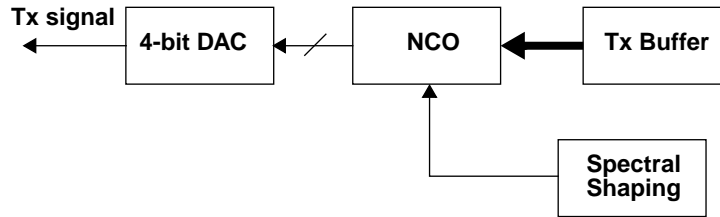

Figure 3. Modulator Block Diagram

Transmit 4-Bit DAC

The transmit DAC clocks one new NCO value out of the Z87001 every 8.192 MHz period. Only the 10.7 MHz alias frequency component of the transmit signal (2.508 + 8.192 MHz image) is filtered, amplified and upconverted to the 900 MHz ISM band by the companion RF module.

Event Trigger Block

The event trigger block is responsible for scheduling the different events happening at the bit and frame levels. The event trigger block receives input from the frame counters as well as the register interface of the DSP core processor.

The event trigger schedules the following events:

- Start of the 4 ms frame: a synthesizer load enable pulse is issued on the SYLE pin
- Power-up of the modulator section and transmission of the frame on handset and base station
- Use of the bit inversion as function of mode
- Power-up of the demodulator section and reception of the frame on handset and base station
- Control of PAON and TXSW output pins, to be used as TDD control signals for the T/R switch as well as the transmitter and receiver chains on the RF module
- Control of RFEON pin, to be used as general on/off switch on the RF module
- Control of the Z87001 sleep mode

4-Bit DAC for Setting Transmit Power Level

In order to save battery life, the Z87001 only transmits the amount of RF power needed to reach the remote receiver with a sufficient SNR margin. The on-board transmit power 4-bit DAC provides 4 different voltage levels to the power amplifier in the RF module for that purpose. This DAC is di-

rectly controlled by the Z87001 software through an output register.

8-Bit ADC for Sampling the Received Signal Strength Indicator (RSSI)

RSSI information is typically generated from the last stage of the RF receiver. The RSSI is sampled once per frame by the 8-bit ADC and used by the Z87001 software to compute the necessary Transmit Power Level voltages.

DSP Core Processor

A DSP core processor constitutes the heart of the Z87001. The DSP runs the application software which performs the following functions:

- Register initialization
- Implementation of high-level phone features; control of phone user interface (keypad, Led, etc.)
- Control of the Z87010 ADPCM Processor
- Control of the phone line interface
- Ring detection by DSP processing
- Communication protocol between handset and base station supporting voice and signalling channels
- Control of the RF synthesizer and adaptive frequency hopping algorithm
- Control of the RF power and adaptive power algorithm
- Control of the demodulator (bit synchronizer loop filter, AFC bias estimate filtering)
- Control of the modulator (carrier frequency) and adaptive frequency alignment
- Signalling between base and handset to support above features

FUNCTIONAL DESCRIPTION (Continued)

The DSP core is characterized by an efficient hardware architecture that allows fast arithmetic operations such as multiplication, addition, subtraction and multiply-accumulate of two 16-bit operands. Most instructions are executed in one clock cycle.

The DSP core is operated at the internal speed of 8.192 MHz. It has an internal RAM memory of 512 16-bit words divided in two banks. Six register pointers provide circular buffering capabilities and dual operand fetching. Three vectored interrupts are complemented by a six-level stack. One interrupt is used by the transceiver, while the two remaining vectors are mapped into port P1. In the phone system, one of these interrupts is customarily reserved for the Z87010 ADPCM Processor. The other interrupt can be used for custom purposes.

The Z87001 may access up to 64K 16 bit words of external ROM including 4 words for interrupt and reset vectors. The ROM is mapped at addresses 0000h to 3FFFh, as shown in Figure 13.

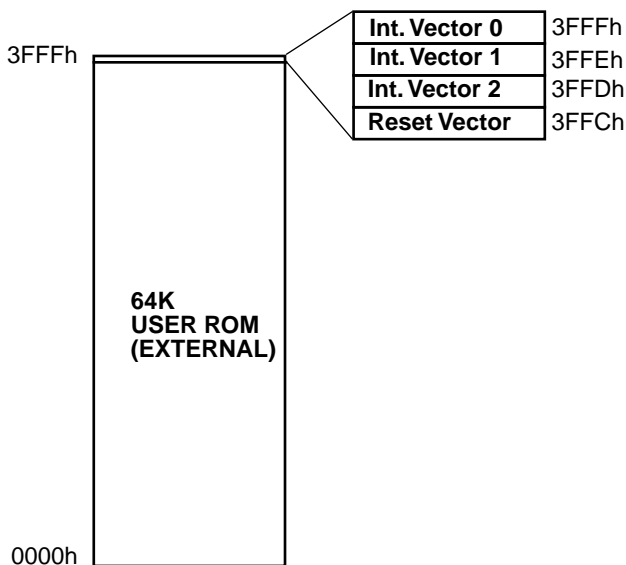

Figure 4. ROM Mapping

Two 16-Bit General-Purpose I/O Ports

Two 16-bit general-purpose I/O ports are directly accessible by the DSP core. These input and output pins are typically used for:

- Implementation of the phone's user interface (keypad, LED, optional display, etc.)
- Control of phone line interface (on/off hook, ring detect)

- Control of battery charging and detection of low battery conditions
- Implementation of additional features for customizing of the phone

Z87010 Interface

In addition to providing clock signals to the Z87010 processor, the Z87001 interfaces to the Z87010 through two different paths:

- A command/status interface
- A data interface

The command/status interface consists of two dual-port registers accessible by both Z87001 and Z87010 DSP core processors. On the Z87001 side, the registers are mapped into the DSP core processor's register interface. To allow access by the Z87010, the internal command/status registers can also be decoded on the pinto of the Z87001. Arbitration logic resolves access contentions.

The data interface allows the Z87010 processor direct access to the Z87001's receive and transmit rate buffers. The rate buffers are decoded on the pin to of the Z87001, and dedicated voice processor interface logic handles the addressing within the rate buffers.

The physical interface between Z87001 and Z87010 consists of an 8-bit data bus, a 3-bit address bus and control signals, as summarized in the following:

VXDATA[7.0]	Data bus
VXADD[2.0]	Address bus
VXSTRB	Data Strobe
VXRWB	Read/Write Control
VXRDYB	Read Control

This bus is controlled by the Z87010. Although in the system the Z87010 is enslaved to the Z87001 master, at the physical level the Z87001 acts as a peripheral of the Z87010.

The mapping of the command status and data interfaces from the Z87010 side is given below.

Interface	Address (VXADD [2.0])	Read /Write	Data (VXDATA[7.0])
Transmit rate buffer	1	W	----3210
Receive rate buffer	1	R	----3210
Command	0	R	76543210
Status	0	W	76543210

OPERATION

Automatic Frequency Control Loop (Receiver) and Modulator

AFC Loop

The AFC loop consists of a bias estimator block, which determines frequency offsets in the incoming signal, an adder, to add this bias to the 460 kHz frequency control word driving the NCO, and various interface points to the DSP core processor. In particular, the DSP can read the bias estimate data and substitute its own calculated bias value to the NCO.

The bias estimator accumulates the discriminator output values (image of instantaneous frequency) that exceed a programmable threshold (BIAS_THRESHOLD). The processor can freeze the bias calculation any time by resetting the BIAS_ENABLE control bit.

The accumulated bias, available in BIAS_ERROR_DATA, can be used directly to correct the NCO frequency. Alternately, the estimated bias can be read by the DSP, further processed, and written to the CORE_BIAS_DATA field. The DSP controls which value is used by setting the USE_CORE_BIAS field. The selected value is added to the 460 kHz signal which downconverts the receive IF signal.

The CORE_BIAS_DATA and BIAS_ERROR_DATA are two's complement numbers in units of 125 Hz.

In addition to correcting the difference in clock frequencies on the receiver using the AFC loop, a Z87001-base system can also modify the frequency of the remote transmit IF signals. The software has access to this frequency through the MOD_FREQ register fields.

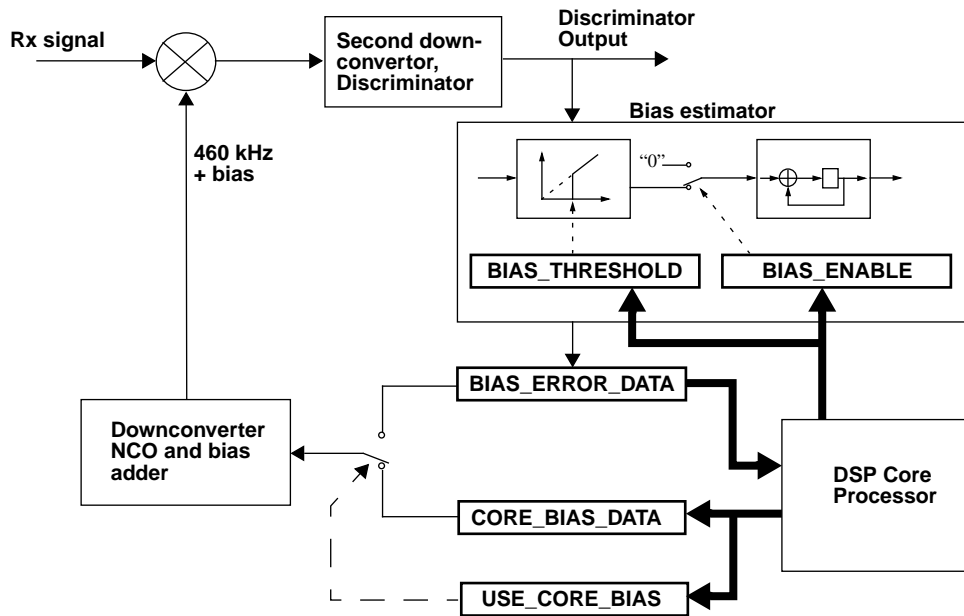

Figure 5. AFC Loop and Processor Control

OPERATION (Continued)

Modulator Control

The MOD_FREQ fields specify the carrier center frequency (should be programmed to 2.508 MHz) and deviation for the FSK signal (should be programmed to ± 32.58 kHz). In addition, wave shaping is performed on bit transitions, in order to satisfy FCC regulations. Up to four different intermediate deviation values are programmable for each of the two FSK states. The MOD_FREQ fields are programmable in units of 62.5 Hz.

Table 1. AFC and Modulator Control Fields

Field	Register	Bank	EXT
BIAS_THRESHOLD	CONFIG1	3	EXT0
BIAS_ENABLE	SSPSTATE	3	EXT2
BIAS_ERROR_DATA	BIAS_ERROR	2	EXT2
CORE_BIAS_DATA	CORE_BIAS	2	EXT4

Bit Synchronizer

The bit synchronizer circuit is an implementation of the Data-Transition-Tracking Loop (DTTL), best described in “Telecommunications Systems Engineering”, by W. Lindsey and M. Simon (Dover 1973; oh. 9 p. 442). Its operation is summarized in the following block diagram.

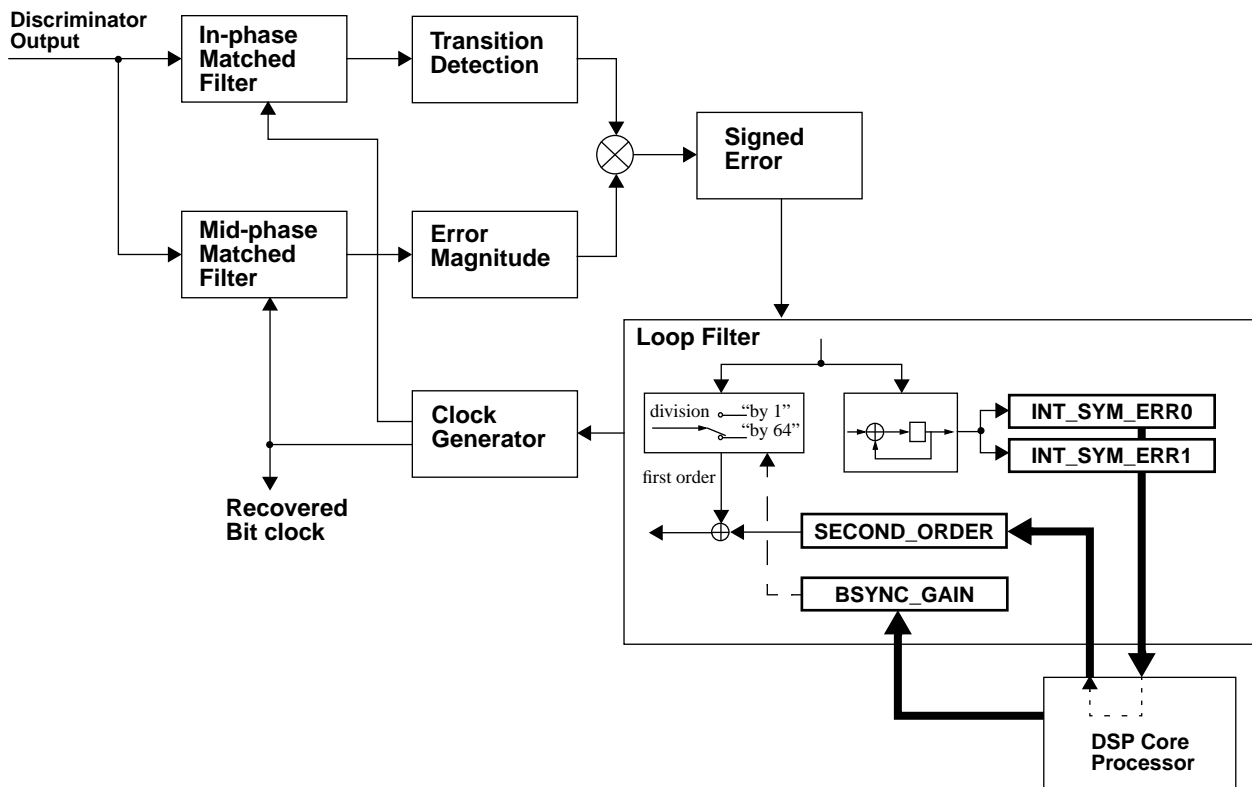

Figure 6. Bit Synchronizer Loop and Processor Control

The loop filter is controlled by the DSP core processor. The DSP core can implement a first order loop by setting the `SECOND_ORDER` field to zero. Typically, the `BSYNC_GAIN` would then be set to “divide-by-1” operation to provide a wide closed loop bandwidth and thus a quick acquisition of the bit clock. When the bit clock is in phase with the input data, the loop bandwidth can be narrowed to maintain tracking of the receive clock with minimum impact from signal noise. To reduce the loop bandwidth, the `BSYNC_GAIN` can be set to “divide-by-64” the first order gain, while the integrated tracking error (available to the DSP in fields `INT_SYM_ERR0` and `INT_SYM_ERR1`) can be used by the DSP software to adjust the `SECOND_ORDER` term.

The bit synchronizer relies on transitions in the received bit stream to operate. The bit inversion logic guarantees enough transitions for all transferred data.

At the handset, the bit synchronizer must track both frequency and phase of the receive signal’s data clock. At the base, only the phase must be tracked. The frequency is inherently correct since the base is the source of the system’s data clock.

Table 2. Bit Synchronizer Control Fields

Field	Register	Bank	EXT
<code>BSYNC_GAIN</code>	<code>SSPSTATE</code>	3	EXT2
<code>INT_SYM_ERR1</code>	<code>BIT_SYNC</code>	1	EXT2
<code>INT_SYM_ERR0</code>	<code>INT_SYM-ERR0</code>	0	EXT6
<code>SECOND_ORDER</code>	<code>BIT_SYNC</code>	1	EXT2

Frame Counters

The handset only has one frame counter, which times all receive and transmit events. The base station has distinct transmit and receive frame counters. When used in this document without any explicit reference to either base or handset, the terms “receive frame counter” and “transmit frame counter” refer to both sides. For the handset, both terms refer to the same unique counter.

The frame counters are clocked at the bit rate, or 93.09 kHz (2.048 MHz/22). Each count lasts one bit = $1000/93.09 = 10.74 \mu\text{s}$.

Each frame lasts 4 ms, which corresponds to $(372 + 8/22)$ bits; the frame counters count from 0 to 371, with the last count lasting a bit longer than the other ones; at the end of count 371, the counters wrap around to 0.

The “hop” command pulse is asserted to pin `SYLE` during count “0” of the frame counter (transmit frame counter on the base station).

Frame Synchronizer, Timings and RF Interface

The frame synchronizer tracks the received frames and resets the receive frame counter. The synchronization is performed by recognizing certain data patterns present in the receive bit stream: a comparison is done on the fly between the data pattern and the incoming bit stream; when the data match, the frame counter is reset.

Two possible 16-bit data patterns are pre-programmed in the Z87001. One is named `UW` (Unique Word) and is used in acquisition mode for first-time synchronization to an incoming signal. `UW` can also be used to track an acquired signal. The second pattern is named `SYNC_D` and is used to track the received data frames while voice is being transferred. The transition from tracking `UW` to tracking `SYNC_D` is controlled by the DSP processor through the `SYNC_SEARCH_WORD` field.

UW Synchronization

When the Z87001 matches the `UW`, the receive frame counter is reset to the value of `UW_LOCATION`. This value is programmable by the DSP processor. On the handset, where the receive frame counter is used to derive all timings, `UW_LOCATION` actually defines the guard time between the frequency hop command and the beginning of data reception, which starts at `FRAME_COUNTER = (UW_LOCATION - 84)` as shown in the next figure.

On the base station, data reception starts when the receive frame counter equals $(UW_LOCATION - 84)$, but this has less significance since the hop pulse is synchronized with the transmit frame counter and there is no fixed relationship between transmit and receive frame counters. On the base station, the `UW_LOCATION` should be set to 301.

OPERATION (Continued)

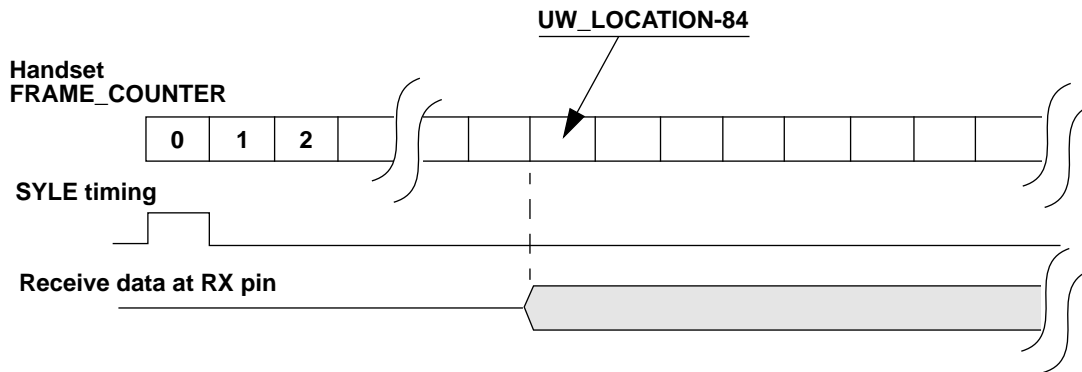

Figure 7. Frame Counter and UW_LOCATION on Handset

Two modes of search are programmable through the SYNC_SEARCH_MODE field: “full search” and “window search”. The full search is used by the handset when first acquiring the signal from the base station. In full search, the handset is in receive mode and continuously looks for a match with the UW. When a match is found and the time reference established (UW_LOCATION is set), the DSP processor on the handset detects the synchronization (see below), switches to Time Division Duplex mode (TDD) and starts receiving and transmitting alternately. The search mode should also be switched to “window search” by the DSP software.

The window search mode only searches for a match in a certain time window centered around the expected match time. The window size is programmable by the DSP processor in the WINDOW_SIZE field. If the matching does not occur at the expected time, due to so-called “bit slips”, the receive frame counter timing is adjusted. Note: although the bit synchronizer is meant to keep track of time and prevent bit slips when the phone is operating continuously in TDD mode, bit slips are still possible when the handset is in standby mode, and only receives once in a while (see description of sleep mode).

SYNC_D Synchronization

When the DSP processor switches the Z87001 operation to voice mode, the frame synchronization parameters should be modified by the DSP software to:

- SYNC_SEARCH_MODE = window search
- SYNC_SEARCH_WORD = SYNC_D pattern

In this mode, the receiver searches for the SYNC_D pattern in windows of the incoming data stream. The window size is determined by the WINDOW_SIZE field.

The transition to voice mode proceeds in two steps, through an intermediate mode. The mode is set by the DSP processor by programming the MULTIPLEX_SWITCH field. The three modes are:

- **SMUX: initial mode.** This mode allows acquisition, AFC operation, UW synchronization and signalling; ADPCM Processor access disabled; bit inversion disabled.
- **STMUX: intermediate mode.** This mode allows SYNC_D frame synchronization and signalling; ADPCM Processor access disabled; bit inversion enabled.
- **TMUX: voice mode.** This mode allows voice transmission, SYNC_D frame synchronization and signalling; ADPCM Processor access enabled; bit inversion enabled.

In order to detect synchronizations, the software has access to the SYNC_ACQ_IND status field. This field is set by the Z87001 matching hardware every time a match is detected within the right time window. The software must reset the “IND” bit by setting the SYNC_ACQ_CLEAR field.

In addition, the software can track the frame timing by reading the frame counter value, available in the FRAME_COUNTER field. On the base station, where two frame counters are in use, this field returns the value of the transmit frame counter.

Every time the frame counter wraps around to 0, a frame start indicator bit is set (FRAME_START_IND status field). The software must reset this “IND” bit by setting the FRAME_START_CLEAR field. If the FS_INT_ENABLE bit is set, frame starts also trigger interrupts to the DSP processor.

The following table summarizes the fields allowing control of frame synchronization and basic frame timing.

Table 3. Frame Synchronizer Control Fields

Field	Register	Bank	Ext
SYNC_SEARCH-MODE	SSPSTATE	3	EXT2
SYNC_SEARCH_WORD	SSPSTATE	3	EXT2
UW_LOCATION	RX_CONTROL	2	EXT1
WINDOW_SIZE	CONFIG1	3	EXT0
MULTIPLEX_SWITCH	SSPSTATE	3	EXT2
SYNC_ACQ_IND	SSPSTATUS	3	EXT3
SYNC_ACQ_CLEAR	SSPSTATE	3	EXT2
FRAME_COUNTER	SSPSTATUS	3	EXT3
FS_INT_ENABLE	CONTROL	1	EXT6
FRAME_START_IND	SSPSTATUS	3	EXT3
FRAME_START_CLEAR	SSPSTATE	3	EXT2
SYNC_SEARCH-MODE	SSPSTATE	3	EXT2

RF Interface

Several control fields are available in the Z87001 register set to control the timing and polarity of the RF module interface signals.

A first field, RFEON_POLARITY, controls the polarity of the RFEON pin. This pin should be used to control the power of the RF module. It is asserted by the Z87001 when the RF module is in use, and de-asserted in sleep mode. The sleep mode is used by the handset to save battery life when no phone call is in process (See "Sleep mode", below).

The SYLE pin (Synthesizer Load Enable), which carries a "load enable" pulse that tells an external RF synthesizer to generate the next RF channel, is controlled by two fields. The HOP_ENABLE field is a global enable signal for the SYLE signals. The SYLE_POLARITY field defines the polarity of the SYLE pin. The system designer should ensure that the leading edge of the SYLE pulse triggers channel hopping.

In addition to the SYLE signal, the interface to the most RF synthesizers includes two more input lines, "data" and "clock", for serial programming of the data values defining the RF channel. In order to allow interfacing to various popular synthesizers, the Z87001 does not have dedicated clock and data lines with fixed timing. Instead, two general I/O pins from ports P0 and P1 can be controlled in software by the DSP core to realize any particular interface timing. This flexibility is made possible by the high speed, single-cycle architecture of the DSP core.

The transmitter control includes a global enable signal for all transmit functions: TX_ENABLE. The transmission start is controlled by the MOD_PWR_ON field. On the base station, the value programmed in MOD_PWR_ON is referenced to the transmit frame counter.

Two additional fields, RFTX_PWR_ON and RFTX_PWR_OFF, define the duty cycle of the PAON output pin. On the base station, these fields are referenced to the transmit frame counter. The RFTX_POLARITY bit defines the polarity of the PAON pin. This pin can be used to control the transmit section and power amplifier of the external RF module.

On the receive side, two fields define the internal timing of the receiver. The start of reception is controlled by the DEMOD_PWR_ON field. Stop of reception (and receiver power down) is controlled by the DEMOD_PWR_OFF field. On the base station, these fields are referenced to the receive frame counter. The RXSW output pin follows the timing defined by the DEMOD_PWR_ON and OFF fields.

Two additional fields, RFRX_PWR_ON and RFRX_PWR_OFF, define the duty cycle of the TXSW output pin. On the base station, these fields are referenced to the TRANSMIT (!) frame counter. The RFRX_POLARITY bit defines the polarity of the TXSW and RXSW pins. The TXSW pin can be used to control the receive section of the external RF module.

The various timing control registers reviewed in this paragraph should be programmed differently for handset and base station. If the same ROM code is used on base and handset, the software can determine which station it runs on by reading the HAND_BASE_SEL bit, which reflects the state of the HBSW pin.

OPERATION (Continued)

The following figure and table summarize the RF interface control fields.

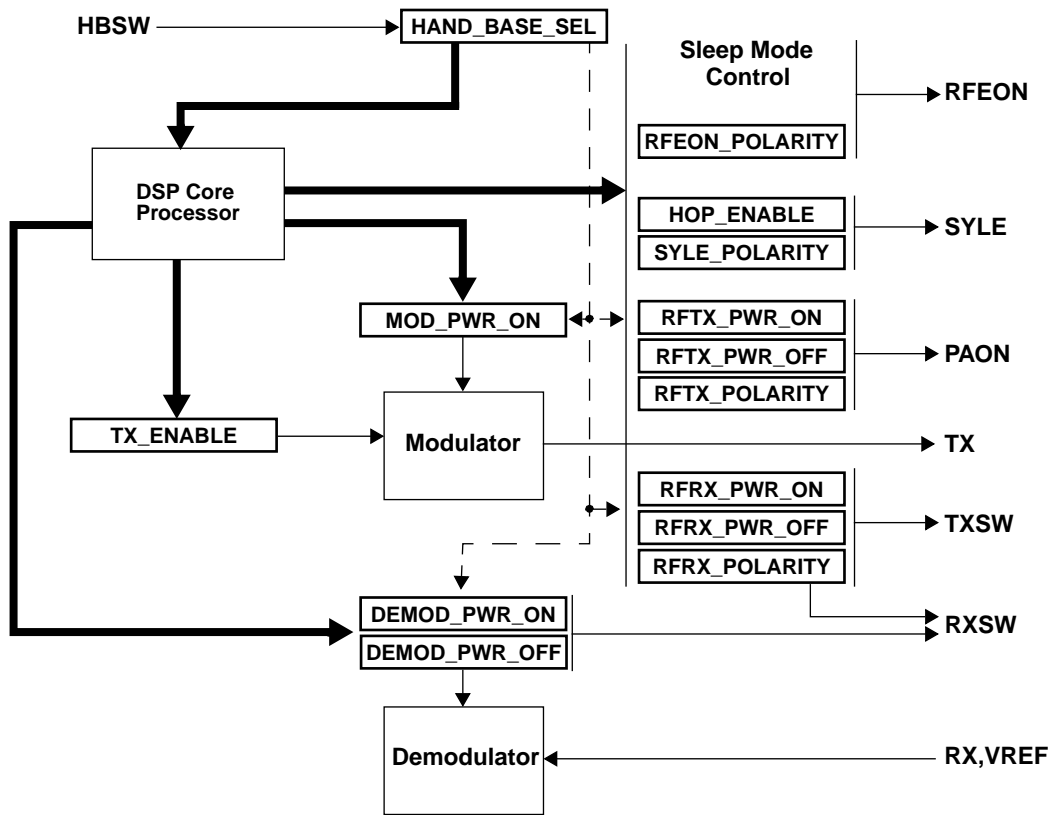

Figure 8. RF interface Control

Table 4. Timing and RF Interface Control Fields

Field	Register	Bank	Ext
RFEON_POLARITY	RX_PWR_CTRL	2	EXT6
HOP_ENABLE	SSPSTATE	3	EXT2
SYLE_POLARITY	CONFIG1	3	EXT0
TX_ENABLE	SSPSTATE	3	EXT2
MOD_PWR_ON	MOD_PWR_CTRL	2	EXT5
RFRX_PWR_ON/OFF	RFRX_PWR_CTRL	0	EXT7
DEMOD_PWR_ON/OFF	DEMOD_PWR_CTRL	2	EXT6
RFRX_POLARITY	RFRX_PWR_CTRL	0	EXT7
RFTX_PWR_ON/OFF	RFTX_PWR_CTRL	2	EXT7
RFTX_POLARITY	RFTX_PWR_CTRL	2	EXT7
HAND_BASE_SEL	SSP_STATUS	3	EXT3

Sleep Mode

To save the phone's battery life on the handset, the Z87001 can be operated in sleep mode while the phone is not in use. The sleep mode is entered by software command. The sleep mode first needs to be enabled by setting the SLEEP_WAKE field. Then a GO_TO_SLEEP command puts the processor to sleep by temporarily stopping its clock. The sleep period can be set to last between 4 ms and 1.02 s by programming the SLEEP_PERIOD field. In sleep mode, the RFEON pin is de-asserted.

The processor comes out of sleep mode in one of two ways. Either the sleep counter counts down to zero, or one of the enabled pins from port P0 is asserted prior to normal expiration of the counter. Four port pins (P0[0..4]) can be individually enabled to provide the wake-up function by setting the appropriate bits in P0_WAKE_ENABLE. Typically, these port pins are connected to the telephone keypad.

When the processor core wakes up, the software needs to know how much time it was actually asleep, in order to restore synchronization to the base station's hopping sequence. For that purpose, the current value of the sleep counter is available to the processor in SLEEP_REMAINING. A value of zero indicates normal expiration of the sleep counter.

In order to guarantee a good operation of the wake-up pins, the wake-up signals are hardware-denounced by the Z87001. Furthermore, these signals are internally synchronized to the bit clock. This ensures that the processor has enough time (one bit time = 10.74 ms) to read a stable value of the remaining sleep time and synchronize correctly to the base station's hopping sequence.

Table 5. Sleep Mode Control Fields

Field	Register	Bank	Ext
SLEEP_EAKE	SSPSTATE	3	EXT2
GO_TO_SLEEP	SSPSTATE	3	EXT2
SLEEP_PERIOD	CONFIG2	3	EXT1
SLEEP_REMAINING	CONFIG2	3	EXT1
P0_WAKEUP_ENABLE	CONTROL	1	EXT6

ADPCM Processor Interface and Rate Buffers

The interface to the ADPCM Processor (Z87010) consists of clock control, command/status interface and data interface. The data interface gives the ADPCM Processor access to the rate buffers.

Clock Interface

The Z87001 generates the Z87010 clock at 16.384 or 8.192 MHz, as set in VP_CLOCK. In addition, the clock can be stopped and restarted with the VP_STOP_CLOCK field in order to reduce power consumption (Note: a software handshaking between Z87001 and Z87010 is necessary before stopping and after restarting the clock).

In addition to providing the Z87010 main clock, the Z87001 generates a CODCLK signal which will be used by the codec and by the Z87010 to synchronize its data transfers with the Z87001. On the base station, the CODCLK is simply obtained by dividing the 16.384 MHz input clock.

On the handset, the CODCLK is synchronized to the base station's CODCLK signal through the receive bit sync logic. This ensures that production and consumption of voice data is happening at identical rates on handset and base, eliminating buffer overrun and underrun situations.

Command/Status Interface

The Z87001 sends commands to the Z87010 through the VP_COMMAND write-only field. It reads the Z87010 status in the VP_STATUS read-only field. Both fields are located at the same address in the Z87001 register interface. A communication protocol should be established in software to ensure correct reception of all commands. Dedicated hardware ensures data integrity when both Z87001 and Z87010 simultaneously access the same register.

Table 6. ADPCM Processor Control Fields

Field	Register	Bank	Ext
VP_CLOCK	CONFIG1	3	EXT0
VP_STOP_CLCOCKS	SSPSTATE	3	EXT2
VP_COMMAND	VP_INOUT	2	EXT0
VP_STATUS	VP_INOUT	2	EXT0

Data Interface and Rate Buffers

The digitized voice data is communicated between the Z87001 and Z87010 through the rate buffers and ADPCM Processor data interface. The transmit and receive rate buffers each contain 36 4-bit nibbles.

To write to the transmit rate buffer, the Z87001 core processor must first set the nibble address in the TX_BUF_ADDR register field, then write the nibble data through TX_BUF_DATA. If the TX_AUTO_INCREMENT bit is set, the address is automatically incremented (modulo 51 = the number of nibbles in rate buffer + 15 additional data words accessible through TX_BUF_DATA; for more information, see Register Description) after each data write. This allows the DSP core to write successive nibbles without resetting the address each time.

OPERATION (Continued)

The operation of the receive rate buffer is identical. The Z87001 core processor must set the nibble address in RX_BUF_ADDR, then read the nibble from RX_BUF_DATA. If the RX_AUTO_INCREMENT bit is set, the read address is automatically incremented (modulo 36 = number of nibbles in rate buffer) after each data read. This allows the DSP core to read successive nibbles without resetting the address each time.

Through its register interface, the Z87001 also controls which rate buffer addresses the Z87010 ADPCM Processor can access. The nibble addresses are contained in the

TX_BUF_VP_ADDR and RX_BUF_VP_ADDR register fields. After the Z87010 writes or reads a nibble to or from transmit or receive rate buffer, the corresponding "VP_ADDR" is automatically incremented (modulo 36) to the next accessible address. The locations of accessible addresses are individually controlled by the Z87001 in the three TX_RX_NIBBLE_MARKER register fields. A marker bit equal to "1" enables the Z87010 to access the corresponding address; a bit equal to "0" causes the Z87010's read or write access to skip to the next nibble that has a marker bit equal to "1".

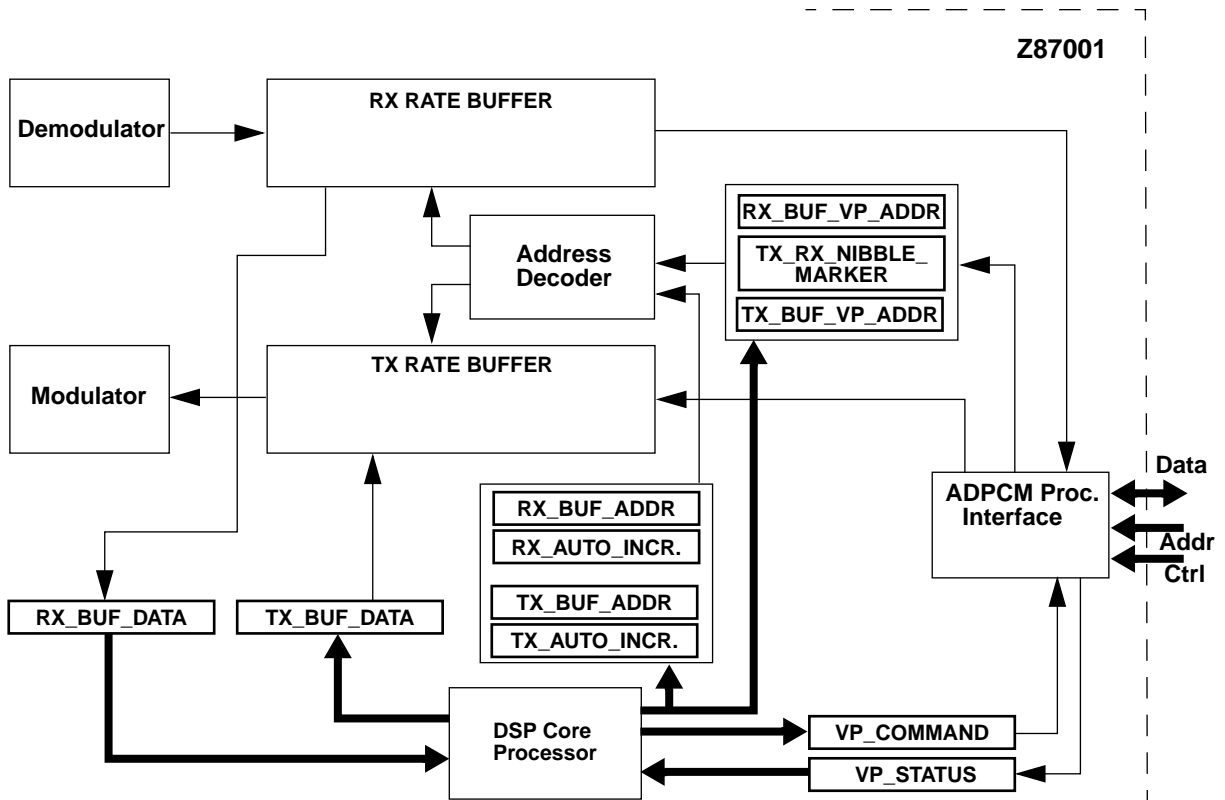

Figure 9. Rate Buffers Access and ADPCM Processor Interface

Table 7. Data and Control Access to Rate Buffers

Field	Register	Bank	Next
RX_AUTO_INCREMENT	RATE_BUF_ADDR	1	EXT0
RX_BUF_ADDR	RATE_BUF_ADDR	1	EXT0
TX_AUTO_INCREMENT	RATE_BUF_ADDR	1	EXT0
TX_BUF_ADDR	RATE_BUF_ADDR	1	EXT0
RX_BUF_DATA	RATE_BUF_DATA	1	EXT0
TX_BUF_DATA	RATE_BUF_ADDR	1	EXT1
TX_BUF_DATA	RATE_BUF_DATA	1	EXT1
RX_BUF_VP_ADDR	RATE_BUF_DATA	1	EXT1
TX_BUF_VP_ADDR	RATE_BUF_DATA	1	EXT1
TX_RX_NIBBLE_MARKER	RATE_BUF_DATA	1	EXT1

ADDITIONAL FEATURES

Power Control

The Z87001 features several means of measuring and controlling power levels. One input pin (RSSI) connects an external “receive signal strength indicator” to a half flash 8-bit ADC in the Z87001. This ADC is sampled once per frame during the receive portion of the TDD cycle. The RSSI value can be accessed in software in the RSSI_DATA register field. With external multiplexing, the 8-bit ADC can be used for additional purposes.

The RSSI data is used by the software to implement adaptive power control. In order to determine whether the RSSI information is made of signal or noise, the Z87001 includes logic to measure the signal-to-noise ratio (SNR) of the receive signal. This SNR value is available at the end of every frame in the SNR_ESTIMATE register field. It is also used by the adaptive frequency hopping algorithm to determine and avoid the noisy channels.

Finally, a 4-bit DAC (resistive ladder) is provided to control RF power output level. The DAC is under software control through register field TX_PWR_DAC_DATA.

Table 8. Power Control

Field	Register	Bank	Ext
RSSI_DATA	RSSI	2	EXT3
SNR_ESTIMATE	RX_CONTROL	2	EXT1
TX_PWR_DAC_DATA	CONTROL	1	EXT6
RSSI_DATA	RSSI	2	EXT3
SNR_ESTIMATE	RX_CONTROL	2	EXT3

General-Purpose I/O Ports

The Z87001 includes two general-purpose input/output ports, P0 and P1, of 16 bit each. The direction of each bit is independently programmable by setting the register fields DIRECTION0 and DIRECTION1. Then, the software can access the input and output values by accessing DATA0 and DATA1.

Two pins of port P1 (pins 14 and 15), when configured in input mode, also behave as interrupt pins for the core processor. The software can enable or disable each interrupt by setting the INTERRUPT_0_ENABLE and INTERRUPT_2_ENABLE fields. The interrupts are positive edge-triggered.

Pin Number	Interrupt Number	DSP Interrupt Vector
P1 14	INT0	3FFFh
P1 15	INT2	3FFDh

Table 9. General-Purpose I/O Ports

Field	Register	Bank	Ext
DIRECTION0	GPI00DIR	3	EXT4
DATA0	GPI00DATA	3	EXT5
DIRECTION1	GPI01DIR	3	EXT6
DATA1	GPI01DATA	3	EXT7
INTERRUPT_0_ENABLE	CONTROL	1	EXT6
INTERRUPT_1_ENABLE	CONTROL	1	EXT6

Four pins of port P0 (pins 0 to 3), when configured in input mode, can also be individually programmed as wake-up pins for the Z87001 (See “Sleep mode”, above).

REGISTER DESCRIPTION

The Z87001 DSP core processor has four banks of eight registers mapped in the core processor's "external register" space, as summarized in the following table.

Table 10. Register Summary

BANK	ADDRESS	REGISTER	READ DESCRIPTION	WRITE DESCRIPTION	TABLE #
Bank 3	EXT0	CONFIG1		Clock Dividers, Use Core Bias, SYLE polarity, search window size, Bias Threshold	Table 25
	EXT1	CONFIG2	Remaining Sleep time	ANT0/1 control, Sleep Period	Table 26
	EXT2	SSPSTATE	Stop VP clock, Absent gain, Bias Enable, Tx Enable, Sync Search control, Hop Enable, Frame Start control, Multiplex control, Sleep mode control		Table 27
	EXT3	SSPSTATUS	Frame Counter, Handset/Base, Sync Search control, Frame Start control		Table 28
	EXT4	GPIO0DIR	General-Purpose I/O port 0 direction control		Table 29
	EXT5	GPIO0DATA	General-Purpose I/O port 0 data		Table 30
	EXT6	GPIO1DIR	General-Purpose I/O port 1 direction control		Table 31
	EXT7	GPIO1DATA	General-Purpose I/O port 1 data		Table 32
Bank 2	EXT0	VP_INOUT	ADPCM Processor Status	ADPCM Processor Command	Table 33
	EXT1	RX_CONTROL	SNR estimate	UW location	Table 34
	EXT2	BIAS_ERROR	FCW value		Table 35
	EXT3	RSSI	8-bit ADC data (RSSI)		Table 36
	EXT4	CORE_BIAS		Core Bias data	Table 37
	EXT5	MOD_PWR_CTRL		MOD_PWR control	Table 38
	EXT6	DEMOD_PWR_CTRL		RXSW, RFEON pin control	Table 39
	EXT7	RFTX_PWR_CTRL		PAON pin control	Table 40
Bank 1	EXT0	RATE_BUF_ADDR		Rate Buffer address	Table 41
	EXT1	RATE_BUF_DATA	Re Rate Buffer data	Tx Rate Buffer data, control data	Table 42
	EXT2	BIT_SYNC	Bit Sync monitoring	Bit Sync control	Table 43
	EXT3	RESERVED			Table 44
	EXT4	RESERVED			Table 44
	EXT5	RESERVED			Table 44
	EXT6	CONTROL	INT, WAKEUP pin control, 4-bit DAC data (PWLV)		Table 45
	EXT7	RESERVED			Table 46
Bank 0	EXT0	RESERVED			Table 47
	EXT1	RESERVED			Table 47
	EXT2	RESERVED			Table 47
	EXT3	RESERVED			Table 47
	EXT4	RESERVED			Table 47
	EXT5	RESERVED			Table 47
	EXT6	INT_SYM_ERR0	Bit Sync monitoring		Table 47
	EXT7	RFRX_PWR_CTRL		TXSW, RXSW pin control	Table 49

REGISTER DESCRIPTION (Continued)

The bank is selectable in software by writing to the core's status register (see Table 24). Once a bank is selected, each of the eight external registers (EXT0 through EXT7) can be accessed by a single-cycle software instruction.

Table 11. Bank Switching

Bank	Status Register	Bank Function
Bank 0	xxxx xxxx x00x xxxx b	Test point access, TDD switching control
Bank 1	xxxx xxxx x01x xxxx b	Rate buffer access, miscellaneous
Bank 2	xxxx xxxx x10x xxxx b	ADPCM processor interface, RF interface, etc.
Bank 3	xxxx xxxx x11x xxxx b	Configuration, status, general-purpose port data and direction

Bank 3 Registers

Table 12. Bank 3 Registers

Config 1 Field	Bank 3 Bit Position	EXT0 R/W	Data	Description
RESERVED	f-----	R		Returns 0
		W		Must be set to 1
VP_CLOCK	-e-----			Controls CLKOUT output pin (clock for ADPCM Processor). Returns 0
			0	CLOCKOUT=16.384 MHz
			1	CLOCKOUT = 8.192
USE_CORE_BIAS	--d-----	R		Controls which bias value is used by the downconverter's NCO as part of the automatic frequency control loop (AFC). Returns 0
		W	0*	Uses BIAS_ERROR_DATA value from AFC hardware
			1	Uses CORE_BIAS_DATA value from DSP core
SYLE_POLARITY	---c-----	R		Controls the polarity of the SYLE output pin (hop pulse). Returns 0
		W	0	SYLE is a positive pulse
			1	SYLE is a negative pulse
WINDOW_SIZE	----ba98-----	R		Defines the search window size (in bits) for windowed search mode (for Unique Word or SYNC_D words). Returns 0
		W	0000	Window size=1
			0001	Window size =3 (1±1)
			...	
			1111	Window size = 31 (1± 15)
BIAS_THRESHOLD	-----76543210	R		Bias estimator threshold value. Returns 0
D		W	XXh	Sets the bias value

Notes:

1. VP_CLOCK. Internally synchronized to avoid glitches. Changes to this bit take effect immediately.
2. SYLE_POLARITY. Changes to this bit take effect immediately.
3. BIAS_THRESHOLD. The bias threshold must be coded as a negative value (opposite of the threshold value) coded in 2's complement. The nominal value for the threshold is -46 (=D3h). Internally, this value is sign-extended to 13 bits.

Table 13. Bank 3 Register EXT1

Config 2 Field	Bank 3 Bit Position	EXT1 R/W	Data	Description
ANTENNA_SW_DEFEAT	f-----	R		Controls optional antenna switching (ANT0 and ANT1 pins) Returns 0
		W	0	Enables antenna switching
			1	Disables antenna switching
ANTENNA_SW_OFFSET	-edcba98-----	R		Controls antenna switching time advancement Returns 0
		W	xXh (<108)	Offset in number of 2.048 MHz clock cycles
SLEEP_PERIOD	-----76543210	W	00h	Programs sleep duration in sleep mode Illegal
			01h	Sleep period=1 frame (4 ms)
			...	
			FFh	Sleep period = 255 frames (1.020s)
SLEEP_REMAINING	-----76543210	R		Returns value of sleep counter when sleep mode is interrupted by a "wake" signal
			00h	Normal expiration of sleep counter
			01h	One frame left before normal expiration
			...	
			FFh	255 frames left before normal expiration

Notes:

1. SLEEP_PERIOD. In sleep mode, the RFEON pin is active. Changes to this bit take effect immediately.
2. SLEEP_REMAINING. A non-zero value indicates that the Z87001 was awakened by a key press activating one of the wake-up pins on port 0. In this case, the processor should immediately reset the SLEEP_WAKE field in SSPSTATE to prevent the process from going back to sleep when the user key press ceases.

REGISTER DESCRIPTION (Continued)

Table 14. Bank 3 Register Description

SSPSTATE Field	Bank 3 Bit Position	EXT2 R/W	Data	Description
SW_SYLE	f-----	R/W	0* 1	Controls accelerated synthesizer programming after sleep Not Active Active
STOP_CODCLK	-e-----	R/W	0* 1	Inhibits toggling of codec clock output during sleep CODCLK is free running CODCLK is frozen high
DBP_STOP_CLOCK	--d-----	R/W	0* 1	Controls toggling of CLKOUT output pin (clock for ADPCM Processor). CLKOUT is free running CLKOUT is frozen high
BSYNC_GAIN	---c-----	R/W	0* 1	Selects gain for first order loop of the bit synchronizer Nominal gain Gain divided by 64
BIAS_ENABLE	----b-----	R/W	0* 1	Controls closed-loop AFC circuit No new bias estimation is performed (latest estimate used) Enables BIAS_ERROR_DATA updates
TX_ENABLE	----a-----	R/W	0* 1	Global enable for all transmit functions Transmitter disabled Transmitter enabled
SYNC_SEARCH_WORD	-----9-----	R/W	0* 1	Controls the word searched for in search mode Search for UW pattern (Unique Word) Search for SYNC_D pattern
SYNC_SEARCH_MODE	-----87-----	R/W	00* 01 10 11	Controls the search mode (and frame synchronization) No search Window search (<= UW_LOCATION & WINDOW_SIZE) Full search (during whole frame) Not used
HOP_ENABLE	-----6-----	R/W	0 1	Enables transmission of the hop pulse on SYLE pin Hop pulse disabled Hop pulse enabled
SYNC_ACQ_CLEAR	-----5-----	R W	1->0	Clears the SYNC_ACQ_IND flag. Returns last value written A transition from 1 to 0 clears the flag
FRAME_START_CLEAR	-----4-----	R W	1->0	Clears the FRAME_START_IND flag Returns last value written A transition from 1 to 0 clears the flag
SLEEP_WAKE	-----3-----	R/W	0 1	Enable bit for entering sleep mode Wake mode only Sleep mode can be activated by GO_TO_SLEEP command
MULTIPLEX_SWITCH	-----21-----	R/W	00* 01 10 11	Controls operation of the transceiver SMUX (bit inversion and ADPCM Processor access disabled) STMUX (bit inv. enabled; ADPCM Proc. access disabled) Reserved TMUX (bit inversion and ADPCM Processor access enabled)

Table 14. Bank 3 Register Description

SSPSTATE Field	Bank 3 Bit Position	EXT2 R/W	Data	Description
GO_TO_SLEEP	-----0	R		Command bit to place the Z87001 in sleep mode Returns last value written
		W	0->1	A transition from 0 to 1 causes Z87001 sleep mode
TX_ENABLE	-----a-----	R/W	0*	Global enable for all transmit functions Transmitter disabled
			1	Transmitter enabled
SYNC_SEARCH_WORD	-----9-----	R/W	0*	Controls the word searched for in search mode Search for UW pattern (Unique Word)
			1	Search for SYNC_D pattern
SYNC_SEARCH_MODE	-----87-----	R/W	00*	Controls the search mode (and frame synchronization) No search
			01	Window search (<= UW_LOCATION & WINDOW_SIZE)
			10	Full search (during whole frame)
			11	Not used
HOP_ENABLE	-----6-----	R/W	0	Enables transmission of the hop pulse on SYLE pin Hop pulse disabled
			1	Hop pulse enabled
SYNC_ACQ_CLEAR	-----5-----	R		Clears the SYNC_ACQ_IND flag. Returns last value written
		W	1->0	A transition from 1 to 0 clears the flag
FRAME_START_CLEAR	-----4-----	R		Clears the FRAME_START_IND flag Returns last value written
		W	1->0	A transition from 1 to 0 clears the flag
SLEEP_WAKE	-----3---	R/W	0	Enable bit for entering sleep mode Wake mode only
			1	Sleep mode can be activated by GO_TO_SLEEP command
MULTIPLEX_SWITCH	-----21-	R/W	00*	Controls operation of the transceiver SMUX (bit inversion and ADPCM Processor access disabled)
			01	STMUX (bit inv. enabled; ADPCM Proc. access disabled)
			10	Reserved
			11	TMUX (bit inversion and ADPCM Processor access enabled)
GO_TO_SLEEP	-----0	R		Command bit to place the Z87001 in sleep mode Returns last value written
		W	0->1	A transition from 0 to 1 causes Z87001 sleep mode

Notes:

1. DBP_STOP_CLOCK. When this bit is set to 1, the ADPCM Processor clock (CLKOUT) is stopped within two clock periods. When this bit is set to 0, the ADPCM Processor clock restarts within two clock periods; in every case, the ADPCM Processor clock minimum specifications for high time and low time are respected.
2. BSYNC_GAIN. Changes to this bit take effect immediately.
BIAS_ENABLE. This bit is a global enable for the Automatic Frequency Control. When the bit is set, the AFC hardware updates the current BIAS_ERROR_DATA during specific time windows, controlled by the event trigger hardware and suitable for a good operation of the AFC. When the bit is reset, the AFC operation is suspended. However, the current BIAS_ERROR_DATA, resulting from previous bias estimations, can still be used to bias the downconverter NCO. Changes to the BIAS_ENABLE bit take effect at the beginning of the frame following the change.
3. TX_ENABLE. Global control for all system transmit functions, including PAON pin control (timing set by the RFTX_PWR_ON/OFF register fields) and power to the modulator and NCO (timing set by MOD_PWR_ON and the wake/sleep modes).
4. Changes to this bit take effect immediately.
5. HOP_ENABLE. Changes to this bit take effect immediately.
6. SLEEP_WAKE. This bit must be set to enable the core to put itself to sleep via the GO_TO_SLEEP command. The SLEEP_WAKE bit must be reset to prevent the core to fall back to sleep after it is awoken by one of the Port 0 Wake-up pins when the sleep period has not expired. If the bit is not reset, the core will fall right back to sleep when the wake-up input is de-asserted (note that by design, a wake-up input has a minimum of 10 ms duration, to allow the software enough time to safely reset the SLEEP_WAKE bit).
7. SYNC_AQC_CLEAR. This bit must be set to "1" again after every "clear" operation to allow for the next "clear".
8. FRAME_START_CLEAR. This bit must be set to "1" again after every "clear" operation to allow for the next "clear".

REGISTER DESCRIPTION (Continued)

Table 15. Bank 3 Register Description

SSPSTATUS Field	Bank 3 Bit Position	EXT3 R/W	Data	Description
FRAME_COUNTER	fedcba987-----	R	00h	Current frame counter value
			...	First value at beginning of frame (0)
			173h	Last value at end of frame (371)
			...	Illegal values
		W		No effect
RESERVED	-----65----	R		Returns 0
		W		No effect
HAND_BASE_SEL	-----4---	R	0	Reflects status of Handset/Base select pin (HBSW)
			1	Base (HBSW = 0)
				Handset (HBSW = 1)
		W		No effect
SYNC_ACQ_IND	-----3--	R	0	Indicates detection of a Sync word (UW or SYNC_D depending on SYNC_SEARCH_WORD search mode)
			1	No sync word detected
		W		Sync word detected
				No effect
FRAME_START_IND	-----2--	R	0	Indicates start of a new frame
			1	No start of new frame (1 written to FRAME_START_CLR)
		W		New frame started
				No effect
RESERVED	-----10	R		Returns 0
		W		No effect

Notes:

FRAME_COUNTER. Read the double-buffered current value of the Frame Counter.

On the handset, a single frame counter is used to clock transmit and receive events.

On the base station, the transmit frame counter value is returned

Table 16. Bank 3 Register Description

GPIODIR Field	Bit 3 Bit Position	EXT4 R/W	Data	Description
DIRECTION0	fedcba9876543210	R/W	..0.	Independent control of Port 0 pin direction
			..1.	Sets pin in input mode
			..1.	Sets pin in output mode

Table 17. Bank 3 Register Description

GPIO0DATA Field	Bank 3 Bit Position	EXT5		Description
		R/W	Data	
DATA0	fedcba9876543210			Access to Port 0 data
		R	XXXXh	Reads pin values
		W	XXXXh	Writes output pin values

Notes:

DATA0. The read value returns the actual pin values and does not depend on the pin directions (i.e. for output pins, the output value is returned unless a contention occurs).

Table 18. Bank 3 Register Description

GPIO1DIR Field	Bank 3 Bit Position	EXT6		Description
		R/W	Data	
DIRECTION1	fedcba9876543210			Independent control of Port 1 pin direction
		R/W	..0.	Pin in input mode
			..1.	Pin in output mode

Table 19. Bank 3 Register Description

GPIO1DATA Field	Bank 3 Bit Position	EXT7		Description
		R/W	Data	
DATA1	fedcba9876543210			Access to Port 1 data
		R	XXXXh	Reads pin values
		W	XXXXh	Writes output pin values

Notes:

DATA1. The read value returns the actual pin values and does not depend on the pin directions (i.e. for output pins, the output value is returned unless a contention occurs)

Bank 2 Registers

Table 20. Bank 2 Register Description

VP_INOUT Field	Bank 2 Bit Position	EXT0 R/W	Data	Description
RESERVED	fedcba98-----	R W		Returns 0 No effect
VP_STATUS	-----76543210	R	XXh	Access to ADPCM Processor's Command/Status mailbox Reads Status byte from ADPCM Processor
VP_COMMAND	-----76543210	W	XXh	Access to ADPCM Processor's Command/Status mailbox Writes Command byte to ADPCM Processor

Table 21. Bank 2 Register Description

RX_CONTROL Field	Bank 2 Bit Position	EXT1 R/W	Data	Description
SNR_ESTIMATE	fedcba9876543210	R	XXXXh	Access to channel measurement (SNR) estimate Returns the SNR value
UW_LOCATION	-----876543210	W	XXXXh	Location of the Unique Word Initializes the value that the receive frame counter is set to on detection of the Unique Word

Notes:

SNR_ESTIMATE. This value is updated every frame. It should be read by the software during the frequency hopping guard time of the next frame.

Table 22. Bank 2 Register Description

BIAS_ERROR Field	Bank 2 Bit Position	EXT2 R/W	Data	Description
BIAS_ERROR_DATA	fedcba9876543210	R W	XXXXh	Access to the bias estimate from the AFC loop. Current bias estimate value No effect

Notes:

BIAS_ERROR_DATA. This value is used to bias the downconverter's NCO if the USE_CORE_BIAS register field is reset. It is encoded as a 2's complement number. The unit is 125 Hz

Table 23. Bank 2 Register Description

RSSI Field	Bank 2 Bit Position	EXT3 R/W	Data	Description
RESERVED	fedcba98-----	R W		Returns 0 No effect
RSSI_DATA	-----76543210	R W	XXh	Access to 8-bit ADC (can be used for RSSI data) Returns latest value on 8-bit DAC No effect

Note:

RSSI_DATA. This value is sampled once per frame (4ms) approximately at bit 72 (middle) of the received data.

Table 24. Bank 2 Register Description

CORE_BIAS Field	Bank 2 Bit Position	EXT4 R/W	Data	Description
RESERVED	fed-----	R W		Returns 0 No effect
CORE_BIAS_DATA	---cba9876543210	R W	xXXXh	Stores bias value for correction of downconverter's NCO. Returns 0 Updates bias value

Notes:

CORE_BIAS_DATA. This value is used if the USE_CORE_BIAS register field is set. It is encoded as a 2's complement number. The unit is 125 Hz.

Table 25. Bank 2 Register Description

MOD_PWR_CTRL Field	Bank 2 Bit Position	EXT5 R/W	Data	Description
RESERVED	f-----	R W		Returns 0 No effect
MOD_PWR_ON	-edcba98-----	R W	xXh	Determines modulator turn-on time referenced to the transmit frame counter Returns 0 Bits 6-0 of turn-on time (= (x modulo 128) - 1)
RESERVED	-----76543210	R W		Returns 0 No effect

Notes:

1. MOD_PWR_ON. Controls the turn-on time for the internal modulator and NCO. Only the 7 LSBs of the 9-bit value necessary to encode an event (from frame counter 0 to 371) are programmable. The two MSBs have fixed values which depend on whether base station or handset is selected: "00" on the base and "01" on the handset. The modulator's turn-off time occurs a fixed time (number of bits) after the turn-on time: 144 bits on the base station, 148 bits on the handset.
2. Changes to this value take effect immediately.
3. To disable the modulator continuously, clear TX_ENABLE

REGISTER DESCRIPTION (Continued)

Table 26. Bank 2 Register Description

DEMOM_PWR_CTRL Field	Bank 2 Bit Position	EXT6 R/W	Data	Description
RFEON_POLARITY	f-----	R W	0 1	Controls the polarity of the RFEON output pin Returns 0 Active high Active Low
DEMOM_PWR_ON	-edcba98-----	R W	xXh	Determines internal power up of demodulator and turn on time of RXSW pin, referenced to the receive frame counter Returns 0 Bits 6-0 of turn-on time $(=(x \text{ modulo } 128) - 1)$
RESERVED	-----7-----	R W		Returns 0 No effect
DEMOM_PWR_OFF	-----6543210	R W	XXh	Determine internal power down of demodulator and turn off time of RXSW pin, referenced to the receive frame counter Returns 0 Bits 6-0 of turn-off time $(=(x \text{ modulo } 128) - 1)$

Notes:

1. DEMOM_PWR_ON, DEMOM_PWR_OFF. Controls internal receive hardware and the RXSW output pin. The turn-on and off times are given in number of received bit periods and are referenced to the Receive Frame Counter. Only the 7 LSBits of the 9-bit value are programmable. The two MSBits have fixed values which depend on whether base station or handset is selected. For DEMOM_PWR_ON, the two bits are "01" on the base and "00" on the handset. For DEMOM_PWR_OFF, the two bits are "10" on the base and "01" on the handset
2. Changes to these values take effect immediately.
3. To enable receive power continuously, clear TX_ENABLE and set SYNC_SEARCH_MODE to FULL_SEARCH (this is the case in acquisition mode).
4. The polarity of the RXSW output pin is controlled by the RFRX_POLARITY bit in the RFRX_PWR_CTRL register

Table 27. Bank 2 Register Description

RFTX_PWR_CTRL Field	Bank 2 Bit Position	EXT7 R/W	Data	Description
RFTX_POLARITY	f-----	R W	0 1	Controls the polarity of the PAON output pin Returns 0 Active high Active Low
RFTX_PWR_ON	-edcba98-----	R W	xXh	Determines PAON output pin turn-on time referenced to the transmit frame counter Returns 0 Bits 6-0 of turn-on time $(=(x \text{ modulo } 128) - 1)$
RESERVED	-----7-----	R W		Returns 0 No effect
RFTX_PWR_OFF	-----6543210	R W	xXh	Determine PAON output pin turn-off time referenced to the transmit frame counter Returns 0 Bits 6-0 of turn-off time $(=(x \text{ modulo } 128) - 1)$

Notes:

1. RFTX_PWR_ON, RFTX_PWR_OFF. Controls the PAON output pin, and thereby the external RF module's transmitter. The turn-on and off times are given in number of transmitted bit periods and are referenced to the transmit Frame Counter. Only the 7 LSBits of the 9-bit value are programmable. The two MSBits have fixed values which depend on whether base station or handset is selected. For RFTX_PWR_ON, the two bits are "00" on the base and "01" on the handset. For RFTX_PWR_OFF, the two bits are "01" on the base and "10" on the handset.
2. Changes to these values take effect immediately.
3. To disable the transmitter continuously, clear TX_ENABLE in SSP_STATE.

Bank 1 Registers

Table 28. Bank 1 Register Description

RATE_BUF_ADDR Field	Bank 1 Bit Position	EXT0 R/W	Data	Description
RESERVED	f-----	R W		Returns 0 No effect
RX_AUTO_INCREMENT	-e-----	R W	0 1	Controls the auto-increment feature of the Rx rate buffer Returns 0 Disables auto-increment Enables auto-increment
RX_BUF_ADDR	--dcba98-----	R W	00h ... 23h ...	Access to Rx rate buffer address Returns 0 Address 0 ... Address 23h = 35 Illegal
RESERVED	-----7-----	R W		Returns 0 No effect
TX_AUTO_INCREMENT	-----6-----	R W	0 1	Controls the auto-increment feature of the Tx rate buffer Returns 0 Disables auto-increment Enables auto-increment
TX_BUF_ADDR	-----543210	R W	00h ... 23h 24h 25h 26h 27h 28h 29h 2Ah 2Bh 2Ch 2Dh 2Eh 2Fh 30h 31h 32h ... Illegal	Access to Tx rate buffer address Returns 0 Address 0 ... Address 23h = 35 Tx/Rx rate buffer address for ADPCM Processor accesses Tx/Rx Nibble Marker bits [15..0] Tx/Rx Nibble Marker bits [31..16] Tx/Rx Nibble Marker bits [35..32] MOD_FREQ_DEV 0 MOD_FREQ_DEV 1 MOD_FREQ_DEV 2 MOD_FREQ_DEV 3 MOD_FREQ_DEV 4 MOD_FREQ_DEV 5 MOD_FREQ_DEV 6 MOD_FREQ_DEV 7 MOD_FREQ_DEV 8 MOD_FREQ_DEV 9 MOD_CENTER_FREQ

REGISTER DESCRIPTION (Continued)

Table 29. Bank 1 Register Description

RATE_BUF_DATA Field	Bank 1 Bit Position	EXT1 R/W	Data	Description
RX_BUF_DATA	-----3210	R	Xh	Access to the Rx rate buffer data Reads value at current RX_BUF_ADDR address (0 to 23h)
TX_BUF_DATA	-----3210	W	XXXXh	Access to the Tx rate buffer data Writes value at current TX_BUF_ADDR address (0 to 23h)
TX_BUF_VP_ADDR	--dcba98-----	W	XXh	Sets the initialization value of the Tx rate buffer address used for ADPCM Processor accesses Writes initialization value (TX_BUF_ADDR address= 24h)
RX_BUF_VP_ADDR	-----543210	W	XXh	Sets the initialization value of the Rx rate buffer address used for ADPCM Processor accesses Writes initialization value (TX_BUF_ADDR address= 24h)
TX_RX_NIBBLE_MARKER	fedcba9876543210	W	XXXXh	Sets the Nibble Marker register for Tx and Rx rate buffer accesses by ADPCM Processor Write nibble marker value (TX_BUF_ADDR= 25h to 27h)
MOD_FREQ	fedcba9876543210	W	XXXXh	Access to modulator settings Writes modulator setting value (TX_BUF_ADDR=28h to 32h)

Note:

The meaning and address for any RATE_BUF_DATA is set in the RATE_BUF_ADDR register.
 MOD_FREQ. The unit for center frequency and frequency deviation words is 62.5 Hz.
 These words are encoded as 2's complement numbers.
 The meaning and address for any RATE_BUF_DATA is set in the RATE_BUF_ADDR register.
 MOD_FREQ. The unit for center frequency and frequency deviation words is 62.5 Hz.
 These words are encoded as 2's complement numbers.

Table 30. Bank 1 Register Description

BIT_SYNC Field	Bank 1 Bit Position	EXT2 R/W	Data	Description
INT_SYM_ERR1	fedcba9876543210	R	XXXXh	Read access to the integrated symbol error from the bit synchronizer's second order loop Reads error data bits [23..8] (bits [7..0] are in bank 0, EXT6)
SECOND_ORDER	fedcba9876543210	W	XXXXh	Write access to the bit synchronizer's second-order loop Writes second order loop's 16-bit value

Table 31. Bank 1 Register Description

RESERVED Field	Bank 1 Bit Position	EXT3 EXT4 EXT5R/W	Data	Description
RESERVED	fedcba9876543210	R W	0000h	Returns 0 Must be left alone or written to 0000h (or unpredictable results may occur)

Table 32. Bank 1 Register Description

CONTROL Field	Bank 1 Bit Position	EXT6 R/W	Data	Description
RESERVED	fedcb-----	R W		Returns 0 No effect
FS_INT_ENABLE	-----a-----	R/W	0* 1	Controls frame start interrupt (INT1) Disables frame start interrupt Enables frame start interrupt
INTERRUPT_0_ENABLE	-----9-----	R/W	0* 1	Controls interrupt 0 (INT0 on P114) Disables interrupt 0 Enables interrupt 0
INTERRUPT_2_ENABLE	-----8-----	R/W	0* 1	Controls interrupt 2 (INT2 on P115) Disables interrupt 2 Enables interrupt 2
P0_WAKEUP_ENABLE	-----7654-----	R/W	0000* 1xxx x1xx xx1x xxx1	Controls wake-up pins (P0[3..0]) Disables all wake-up pins Enables P03 as wake-up pin (if in input mode) Enables P02 as wake-up pin (if in input mode) Enables P01 as wake-up pin (if in input mode) Enables P00 as wake-up pin (if in input mode)
TX_PWR_DAC_DATA	-----3210	R/W	Xh	Access to Tx power 4-bit DAC output data Sets output value

Note:

P0_WAKEUP_ENABLE. When enabled, pins P0[3..0] are active low wake-up pins for the Z87001 sleep mode. The input signal is internally debounced and synchronized to the bit clock. It is internally given a minimum duration of one bit to allow the software to exit sleep mode safely.

Table 33. Bank 1 Register Description

RESERVED Field	Bank 1 Bit Position	EXT7 R/W	Data	Description
RESERVED	fedcba9876543210	R W		Returns 0 No effect

Bank 0 Registers

Table 34. Bank 0 Register Description

RESERVED Field	Bank 0 Bit Position	EXT0	Data	Description
		R/W		
RESERVED	fedcba9876543210	R	Returns 0	
		W	No effect	

Table 35. Bank 0 Register Description

INT_SYM_ERR0 Field	Bank 0 Bit Position	EXT6	Data	Description
		R/W		
RESERVED	fedcba98-----	R	Returns 0	
		W	No effect	
INT_SYM_ERR0	-----76543210	R	XXh	Read access to the integrated symbol error from the bit synchronizer's second order loop Reads error data bits [7..0] (bits [23..8] are in bank1, EXT2)
		W		No effect

Table 36. Bank 0 Register Description

RFRX_PWR_CTRL Field	Bank 0 Bit Position	EXT7 R/W	Data	Description
RFRX_POLARITY	f-----	R W	0 1	Controls the polarity of the TXSW (and RXSW) output pins Returns 0 TXSW active Low and RXSW active High TXSW active High and RXSW active Low
RFRX_PWR_ON	-edcba98-----	R W	xXh	Determines TXSW output pin turn-on time referenced to the transmit frame counter Returns 0 Bits 6-0 of turn-on time $(=(x \text{ modulo } 128) - 1)$
RESERVED	-----7-----	R W		Returns 0 No effect
RFRX_PWR_OFF	-----6543210	R W	xXh	Determine TXSW output pin turn-off time referenced to the transmit frame counter Returns 0 Bits 6-0 of turn-off time $(=(x \text{ modulo } 128) - 1)$

Notes:

1. RFRX_POLARITY. Caution: notice the inverse polarity of the TXSW pin.
2. RFRX_PWR_ON, RFRX_PWR_OFF. Controls the TXSW output pin. The turn-on and off times are given in number of transmitted bit periods and are referenced to the TRANSMIT (!) Frame Counter. Only the 7 LSBits of the 9-bit value are programmable. The two MSBits have fixed values which depend on whether base station or handset is selected. For RFRX_PWR_ON, the two bits are "00" on the base and "01" on the handset. For RFRX_PWR_OFF, the two bits are "01" on the base and "10" on the handset.
3. Changes to these values take effect immediately.
4. To disable transmit power continuously, clear TX_ENABLE.

INSTRUCTION SET DESCRIPTION

Refer to Zilog's Z89C00 User's Manual, Chapter 5 (Instruction Set Features) and Chapter 6 (Assembly Language Instruction Set), for a complete description of the core processor's instruction set.

Table 37. Instruction Set Summary

Instruction	Description	Opcode	Synopsis	Operands	# Words	# Cycles	Example
ABS	Absolute Value	1001000	ABS[<cc>,<src>	<cc>,A	1	1	ABS NC,A
		1001000		A	1	1	ABS A
ADD	Addition	1001001	ADD<dest>,<src>	A,<pregs>	1	1	ADD A,P0:0
		1000001		A,<dregs>	1	1	ADD A,D0:0
		1000100		A,<limm>	2	2	ADD A,#%1234
		1000101		A,<memind>	1	3	ADD A,@@P0:0
		1000011		A,<direct>	1	1	ADD A,%F2
		1000001		A,<regind>	1	1	ADD A,@P1:1
		1000000		A,<hwregs>	1	1	ADD A,X
		AND		Bitwise AND	1011001	AND<dest>,<src>	A,<pregs>
1010001	A,<dregs>		1		1		AND A,D0:1
1010100	A,<limm>		2		2		AND A,#%1234
1010101	A,<memind>		1		3		AND A,@@P1:0
1010001	A,<direct>		1		1		AND A,%2C
1010001	A,<regind>		1		1		AND A,@P1:2+LOOP
1010000	A,<hwregs>		1		1		AND A,EXT3
CALL	Subroutine call		0010100		CALL [<cc>,<address>		<cc>,<direct>
		0010100	<direct>	2		2	CALL Z,sub2
CCF	Clear carry flag	1001010	CCF	None	1	1	CCF
CIEF	Clear Carry Flag	1001010	CIEF	None	1	1	CIEF
COPF	Clear OP flag	1001010	COPF	None	1	1	COPF
CP	Comparison	0111001	CP<src1>,<src2>	A,<pregs>	1	1	CP A,P0:0
		0110001		A,<dregs>	1	1	CP A,D3:1
		0110101		A,<memind>	1	3	CP A,@@P0:0
		0110011		A,<direct>	1	1	CP A,%FF
		0110001		A,<regind>	1	1	CP A,@P2:1+
		0110000		A,<hwregs>	1	1	CP A,STACK
		0110100		A,<limm>	2	2	CP A,#%FFCF
		DEC		Decrement	1001000	DEC [<cc>,<dest>	<cc>,A,
1001000	A		1		1		DEC A
INC	Increment	1001000	INC [<cc>,<dest>	<cc>,A	1	1	INC PL,A
		1001000		A	1	1	INC A
JP	Jump	0100110	JP [<cc>,<address>	<cc>,<direct>	2	2	JP NIE,Label
		0100110		<direct>	2	2	JP Label

Table 37. Instruction Set Summary

Instruction	Description	Opcode	Synopsis	Operands	# Words	# Cycles	Example
LD	Load destination with source	0000000	LD<dest>,<src>	A,<hwregs>	1	1	LD A,X
		0000001		A,<dregs>	1	1	LD A,D0:0
		0001001		A,<pregs>	1	1	LD A,P0:1
		0000001		A,<regind>	1	1	LD A,@P1:1
		0000101		A,<memind>	1	3	LD A,@D0:0
		0000011		A,<direct>	1	1	LD A, 124
		0000111		<direct>,A	1	1	LD 124, A
		0000100		<dregs>,<hwregs>	1	1	LD D0:0, EXT7
		0001100		<pregs>,<sim>	1	1	LD P1:1,#%FA
		0001010		<pregs>,<hwregs>	1	1	LD P1:1,EXT1
		0000110		<regind>,<limm>	1	1	LD @P1:1,#%1234
		0000010		<regind>,<hwregs>	1	1	LD @P1:1+,X
		0001001		<hwregs>,<pregs>	1	1	LD Y,P0:0
		0000001		<hwregs>,<dregs>	1	1	LD SR,D0:0
		0000100		<hwregs>,<limm>	2	2	LD PC,#%1234
		0100101		<hwregs>,<accind>	1	3	LD X,@A
		0000101		<hwregs>,<memind>	1	3	LD Y,@D0:0
		0000001		<hwregs>,<regind>	1	1	LD A,@P0:0-LOOP
0000000		<hwregs>,<hwregs>	1	1	LD X, EXT6		
MLD	Multiply	1010010	MLD<srcl>,<srcl>	<hwregs>,<regind>	1	1	MLD A,@P0:0+LOOP
		1010010	[,<bank switch>]	<hwregs>,<regind>,<bank switch>	1	1	MLD A,@P1:0,OFF
		1011011		<regind>,<regind>	1	1	MLD @P1:1,@P2:0
		1011011		<regind>,<regind>,<bank switch>	1	1	MLD@P0:1,@P1:0,ON
MPYA	Multiply and add	1010010	MPYA <srcl>,<src2>	<hwregs>,<regind>	1	1	MPYA A@P0:0
		1010010	[,<bank switch>]	<hwregs>,<regind>,<bank switch>	1	1	MPYA A,@P1:0,OFF
		1011011		<regind>,<regind>	1	1	MPYA @P1:1,@P2:0
		1011011		<regind>,<regind>,<bank switch>	1	1	MPYA@P0:1,@P1:0,ON
MPYS	Multiply and subtract	0010010	MPYS<src1>,<src2>	<hwregs>,<regind>	1	1	MPYS A,@P0:0
		0010010	[,<bank switch>]	<hwregs>,<regind>,<bank switch>	1	1	MPYS A,@P1:0,OFF
		0011011		<regind>,<regind>	1	1	MPYS @P1:1,@P2:0
		0011011		<regind>,<regind>,<bank switch>	1	1	MPYS@P0:1,@P1:0,ON
NEG	Negate	1001000	NEG <cc>,A	<cc>, A	1	1	NEG NZ,A
		1001000		A	1	1	NEG A
NOP	No operation		NOP	None			
		0000000			1	1	NOP
OR	Bitwise OR	1101001	OR <dest>,<src>	A, <pregs>	1	1	OR A, P0:1
		1100001		A, <dregs>	1	1	OR A, D0:1
		1100100		A, <limm>	2	2	OR A,#%202
		1100101		A, <memind>	1	3	OR A,@@P2:1+
		1100011		A, <direct>	1	1	OR A, %2C
		1100001		A, <regind>	1	1	OR A, @P1:0-LOOP
		1100000		A, <hwregs>	1	1	OR A, EXT6

Table 37. Instruction Set Summary

Instruction	Description	Opcode	Synopsis	Operands	# Words	# Cycles	Example
POP	Pop value from stack	0001010	POP <dest>	<pregs>	1	1	POP P0:0
		0000100		<regs>	1	1	POP D0:1
		0000010		<regind>	1	1	POP @P0:0
		0000000		<hwregs>	1	1	POP A
PUSH	Push value onto stack	0001001	PUSH <src>	<pregs>	1	1	PUSH P0:0
		0000001		<dregs>	1	1	PUSH D0:1
		0000001		<regind>	1	1	PUSH @P0:0
		0000000		<hwregs>	1	1	PUSH BU5
		0000100		<limm>	2	2	PUSH #12345
		0100101		<accind>	1	3	PUSH @A
		0000101		<memind>	1	3	PUSH @@P0:0
RET	Return from subroutine	0000000	RET	None	1	2	RET
RL	Rotate Left	1001000	RL <cc>,A	<cc>,A	1	1	RL NZ,A
		1001000		A	1	1	RL A
RR	Rotate Right	1001000	RR <cc>,A	<cc>,A	1	1	RR C,A
		1001000		A	1	1	RR A
SCF	Set C flag	1001010	SCF	None	1	1	SCF
SIEF	Set IE flag	1001010	SIEF	None	1	1	SIEF
SLL	Shift left logical	1001000	SLL	[<cc>],A	1	1	SLL NZ,A
		1001000		A	1	1	SLL A
SOPF	Set OP flag	1001010	SOPF	None	1	1	SOPF
SRA	Shift right arithmetic	1001000	SRA<cc>,A	<cc>,A	1	1	SRA NZ,A
		1001000		A	1	1	SRA A
SUB	Subtract	0011001	SUB<dest>,<src>	A,<pregs>	1	1	SUB A,P1:1
		0010011		A,<dregs>	1	1	SUB A,D0:1
		0010100		A,<limm>	2	2	SUB A,#%2C2C
		0010101		A,<memind>	1	3	SUB A,@D0:1
		0010011		A,<direct>	1	1	SUB A,%15
		0010001		A,<regind>	1	1	SUB A,@P2:0-LOOP
		0010000		A,<hwregs>	1	1	SUB A,STACK
XOR	Bitwise exclusive OR	1111001	XOR <dest>,<src>	A,<pregs>	1	1	XOR A,P2:0
		1110001		A,<dregs>	1	1	XOR A,D0:1
		1110100		A,<limm>	2	2	XOR A,#13933
		1110001		A,<memind>	1	3	XOR A,@P2:1+
		1110011		A,<direct>	1	1	XOR A,%2F
		1110001		A,<regind>	1	1	XOR A,@P2:0
		1110000		A,<hwregs>	1	1	XOR A,BUS