

n FEATURES

- ✓ Wide V_{CC} operation voltage : 2.4V ~ 5.5V
- ✓ Very low power consumption :
 - $V_{CC} = 3.0V$ Operation current : 18mA (Max.) at 55ns
2mA (Max.) at 1MHz
Standby current : 0.02uA (Typ.) at 25°C
 - $V_{CC} = 5.0V$ Operation current : 47mA (Max.) at 55ns
10mA (Max.) at 1MHz
Standby current : 0.4uA (Typ.) at 25°C
- ✓ High speed access time :
 - 55 55ns (Max.) at $V_{CC} : 3.0\sim 5.5V$
 - 70 70ns (Max.) at $V_{CC} : 2.7\sim 5.5V$
- ✓ Automatic power down when chip is deselected
- ✓ Easy expansion with CE2, CE1 and OE options
- ✓ Three state outputs and TTL compatible
- ✓ Fully static operation
- ✓ Data retention supply voltage as low as 1.5V

n DESCRIPTION

The BS62LV1027 is a high performance, very low power CMOS Static Random Access Memory organized as 131,072 by 8 bits and operates form a wide range of 2.4V to 5.5V supply voltage. Advanced CMOS technology and circuit techniques provide both high speed and low power features with typical CMOS standby current of 0.02uA at 3.0V/25°C and maximum access time of 55ns at 3.0V/85°C.

Easy memory expansion is provided by an active LOW chip enable (CE1), an active HIGH chip enable (CE2), and active LOW output enable (OE) and three-state output drivers.

The BS62LV1027 has an automatic power down feature, reducing the power consumption significantly when chip is deselected.

The BS62LV1027 is available in DICE form, JEDEC standard 32 pin 450mil Plastic SOP, 600mil Plastic DIP, 8mmx13.4mm STSOP, 8mmx20mm TSOP and 36-ball BGA package.

n POWER CONSUMPTION

PRODUCT FAMILY	OPERATING TEMPERATURE	POWER DISSIPATION								PKG TYPE
		STANDBY ($I_{CCSB1, Max.}$)		Operating ($I_{CC, Max.}$)						
		$V_{CC}=5.0V$	$V_{CC}=3.0V$	$V_{CC}=5.0V$			$V_{CC}=3.0V$			
		1MHz	10MHz	$f_{Max.}$	1MHz	10MHz	$f_{Max.}$			
BS62LV1027DC	Commercial +0°C to +70°C	3.0uA	1.0uA	9mA	29mA	46mA	1.5mA	9mA	17mA	DICE
BS62LV1027HC										BGA-36-0608
BS62LV1027PC										PDIP-32
BS62LV1027SC										SOP-32
BS62LV1027STC										STSOP-32
BS62LV1027TC										TSOP-32
BS62LV1027HI	Industrial -40°C to +85°C	5.0uA	1.5uA	10mA	30mA	47mA	2mA	10mA	18mA	BGA-36-0608
BS62LV1027PI										PDIP-32
BS62LV1027SI										SOP-32
BS62LV1027STI										STSOP-32
BS62LV1027TI										TSOP-32

n PIN CONFIGURATIONS

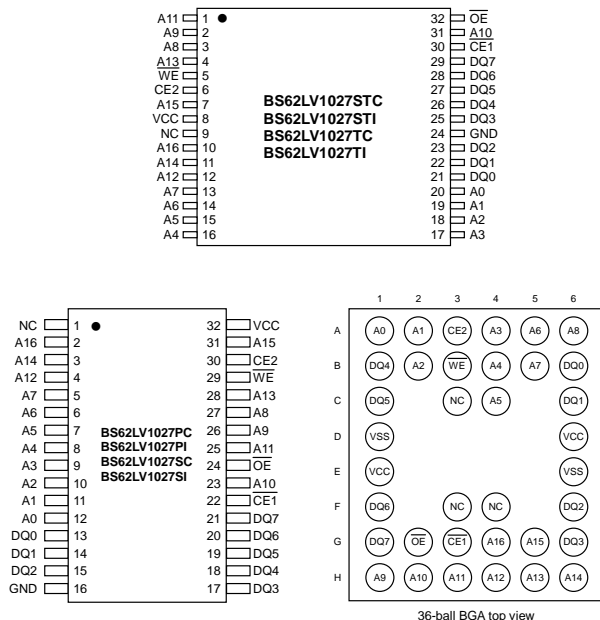

n BLOCK DIAGRAM

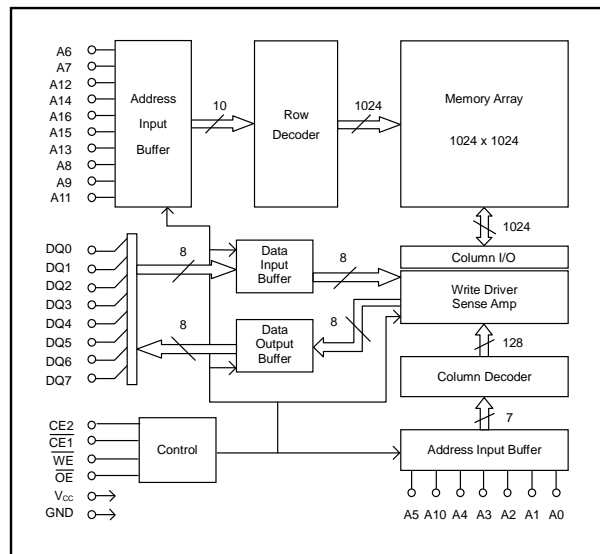

Brilliance Semiconductor, Inc. reserves the right to change products and specifications without notice.

n PIN DESCRIPTIONS

Name	Function
A0-A16 Address Input	These 17 address inputs select one of the 131,072 x 8-bit in the RAM
CE1 Chip Enable 1 Input CE2 Chip Enable 2 Input	CE1 is active LOW and CE2 is active HIGH. Both chip enables must be active when data read from or write to the device. If either chip enable is not active, the device is deselected and is in standby power mode. The DQ pins will be in the high impedance state when the device is deselected.
WE Write Enable Input	The write enable input is active LOW and controls read and write operations. With the chip selected, when WE is HIGH and OE is LOW, output data will be present on the DQ pins; when WE is LOW, the data present on the DQ pins will be written into the selected memory location.
OE Output Enable Input	The output enable input is active LOW. If the output enable is active while the chip is selected and the write enable is inactive, data will be present on the DQ pins and they will be enabled. The DQ pins will be in the high impedance state when OE is inactive.
DQ0-DQ7 Data Input/Output Ports	There 8 bi-directional ports are used to read data from or write data into the RAM.
V_{CC}	Power Supply
GND	Ground

n TRUTH TABLE

MODE	CE1	CE2	WE	OE	I/O OPERATION	V _{CC} CURRENT
Not selected (Power Down)	H	X	X	X	High Z	I _{CCSB} , I _{CCSB1}
	X	L	X	X		
Output Disabled	L	H	H	H	High Z	I _{CC}
Read	L	H	H	L	D _{OUT}	I _{CC}
Write	L	H	L	X	D _{IN}	I _{CC}

n ABSOLUTE MAXIMUM RATINGS ⁽¹⁾

SYMBOL	PARAMETER	RATING	UNITS
V _{TERM}	Terminal Voltage with Respect to GND	-0.5 ⁽²⁾ to 7.0	V
T _{BIAS}	Temperature Under Bias	-40 to +125	°C
T _{STG}	Storage Temperature	-60 to +150	°C
P _T	Power Dissipation	1.0	W
I _{OUT}	DC Output Current	20	mA

1. Stresses greater than those listed under ABSOLUTE MAXIMUM RATINGS may cause permanent damage to the device. This is a stress rating only and functional operation of the device at these or any other conditions above those indicated in the operational sections of this specification is not implied. Exposure to absolute maximum rating conditions for extended periods may affect reliability.

2. -2.0V in case of AC pulse width less than 30 ns.

n OPERATING RANGE

RANG	AMBIENT TEMPERATURE	V _{CC}
Commercial	0°C to + 70°C	2.4V ~ 5.5V
Industrial	-40°C to + 85°C	2.4V ~ 5.5V

n CAPACITANCE ⁽¹⁾ (T_A = 25°C, f = 1.0MHz)

SYMBOL	PARAMETER	CONDITIONS	MAX.	UNITS
C _{IN}	Input Capacitance	V _{IN} = 0V	6	pF
C _{IO}	Input/Output Capacitance	V _{I/O} = 0V	8	pF

1. This parameter is guaranteed and not 100% tested.

n DC ELECTRICAL CHARACTERISTICS (T_A = -40°C to +85°C)

PARAMETER NAME	PARAMETER	TEST CONDITIONS	MIN.	TYP. ⁽¹⁾	MAX.	UNITS
V _{CC}	Power Supply		2.4	--	5.5	V
V _{IL}	Input Low Voltage		-0.5 ⁽²⁾	--	0.8	V
V _{IH}	Input High Voltage		2.2	--	V _{CC} +0.3 ⁽³⁾	V
I _{IL}	Input Leakage Current	V _{CC} = Max, V _{IN} = 0V to V _{CC}	--	--	1	uA
I _{LO}	Output Leakage Current	V _{CC} = Max, $\overline{CE1} = V_{IH}$, CE2 = V _{IL} , or OE = V _{IH} , V _{I/O} = 0V to V _{CC}	--	--	1	uA
V _{OL}	Output Low Voltage	V _{CC} = Max, I _{OL} = 2.0mA			0.4	V
V _{OH}	Output High Voltage	V _{CC} = Min, I _{OH} = -1.0mA			--	V
I _{CC} ⁽⁵⁾	Operating Power Supply Current	$\overline{CE1} = V_{IL}$, CE2 = V _{IH} , I _{DQ} = 0mA, f = f _{Max} ⁽⁴⁾			18	mA
					47	
I _{CC1}	Operating Power Supply Current	CE1 = V _{IL} , CE2 = V _{IH} , I _{DQ} = 0mA, f = 1MHz			2	mA
					10	
I _{CCSB}	Standby Current – TTL	$\overline{CE1} = V_{IH}$, or CE2 = V _{IL} , I _{DQ} = 0mA			0.5	mA
					1.0	
I _{CCSB1} ⁽⁶⁾	Standby Current – CMOS	$\overline{CE1} \geq V_{CC}-0.2V$ or CE2 $\leq 0.2V$, V _{IN} $\geq V_{CC}-0.2V$ or V _{IN} $\leq 0.2V$		0.02	1.5	uA
				0.4	5.0	

1. Typical characteristics are at T_A=25°C and not 100% tested.
2. Undershoot: -1.0V in case of pulse width less than 20 ns.
3. Overshoot: V_{CC}+1.0V in case of pulse width less than 20 ns.
4. f_{Max}=1/t_{RC}.
5. I_{CC(MAX)} is 17mA/46mA at V_{CC}=3.0V/5.0V and T_A=70°C.
6. I_{CCSB1(MAX)} is 1.3uA/4.0uA at V_{CC}=3.0V/5.0V and T_A=70°C.

n DATA RETENTION CHARACTERISTICS (T_A = -40°C to +85°C)

SYMBOL	PARAMETER	TEST CONDITIONS	MIN.	TYP. ⁽¹⁾	MAX.	UNITS
V _{DR}	V _{CC} for Data Retention	$\overline{CE1} \geq V_{CC}-0.2V$ or CE2 $\leq 0.2V$, V _{IN} $\geq V_{CC}-0.2V$ or V _{IN} $\leq 0.2V$	1.5	--	--	V
I _{CCDR} ⁽³⁾	Data Retention Current	$\overline{CE1} \geq V_{CC}-0.2V$ or CE2 $\leq 0.2V$, V _{IN} $\geq V_{CC}-0.2V$ or V _{IN} $\leq 0.2V$	--	0.02	0.5	uA
t _{CDR}	Chip Deselect to Data Retention Time	See Retention Waveform	0	--	--	ns
t _R	Operation Recovery Time		t _{RC} ⁽²⁾	--	--	ns

1. V_{CC}=1.5V, T_A=25°C and not 100% tested.
2. t_{RC} = Read Cycle Time.
3. I_{CCDR(MAX)} is 0.3uA at T_A=70°C.

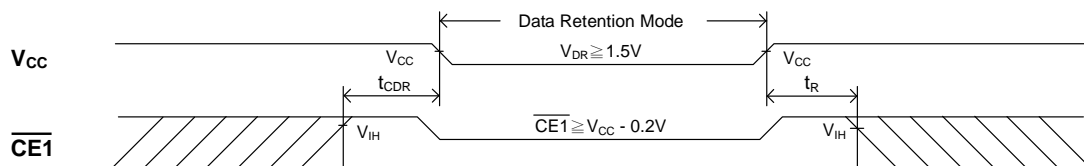
n LOW V_{CC} DATA RETENTION WAVEFORM (1) ($\overline{CE1}$ Controlled)

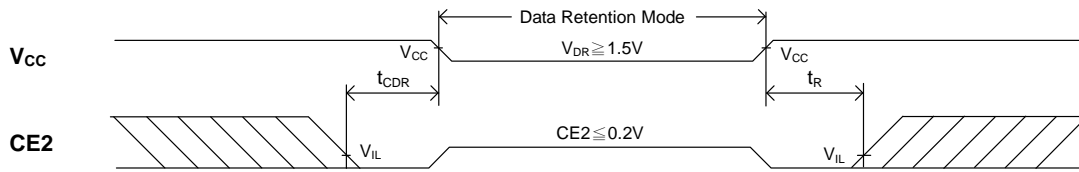

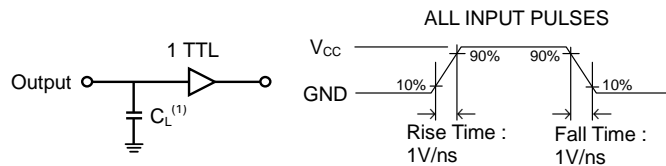

n LOW V_{CC} DATA RETENTION WAVEFORM (2) (CE2 Controlled)

n AC TEST CONDITIONS
 (Test Load and Input/Output Reference)

Input Pulse Levels	$V_{CC} / 0V$
Input Rise and Fall Times	1V/ns
Input and Output Timing Reference Level	0.5 V_{CC}
Output Load	$t_{CLZ}, t_{OLZ}, t_{CHZ}, t_{OHZ}, t_{WHZ}$
	Others

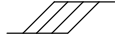

1. Including jig and scope capacitance.

n KEY TO SWITCHING WAVEFORMS

WAVEFORM	INPUTS	OUTPUTS
	MUST BE STEADY	MUST BE STEADY
	MAY CHANGE FROM "H" TO "L"	WILL BE CHANGE FROM "H" TO "L"
	MAY CHANGE FROM "L" TO "H"	WILL BE CHANGE FROM "L" TO "H"
	DON'T CARE ANY CHANGE PERMITTED	CHANGE : STATE UNKNOWN
	DOES NOT APPLY	CENTER LINE IS HIGH IMPEDANCE "OFF" STATE

n AC ELECTRICAL CHARACTERISTICS ($T_A = -40^{\circ}C$ to $+85^{\circ}C$)
READ CYCLE

JEDEC PARAMETER NAME	PARAMETER NAME	DESCRIPTION	CYCLE TIME : 55ns ($V_{CC} = 3.0\sim 5.5V$)			CYCLE TIME : 70ns ($V_{CC} = 2.7\sim 5.5V$)			UNITS
			MIN.	TYP.	MAX.	MIN.	TYP.	MAX.	
t_{AVAX}	t_{RC}	Read Cycle Time	55	--	--	70	--	--	ns
t_{AVQX}	t_{AA}	Address Access Time	--	--	55	--	--	70	ns
t_{E1LQV}	t_{ACS1}	Chip Select Access Time ($\overline{CE1}$)	--	--	55	--	--	70	ns
t_{E2HQV}	t_{ACS2}	Chip Select Access Time ($CE2$)	--	--	55	--	--	70	ns
t_{GLQV}	t_{OE}	Output Enable to Output Valid	--	--	30	--	--	35	ns
t_{E1LQX}	t_{CLZ1}	Chip Select to Output in Low Z ($\overline{CE1}$)	10	--	--	10	--	--	ns
t_{E2HQX}	t_{CLZ2}	Chip Select to Output in Low Z ($CE2$)	10	--	--	10	--	--	ns
t_{GLQX}	t_{OLZ}	Output Enable to Output in Low Z	5	--	--	5	--	--	ns
t_{E1HQZ}	t_{CHZ1}	Chip Deselect to Output in High Z ($\overline{CE1}$)	--	--	30	--	--	35	ns
t_{E2LQZ}	t_{CHZ2}	Chip Deselect to Output in High Z ($CE2$)	--	--	30	--	--	35	ns
t_{GHQZ}	t_{OHZ}	Output Disable to Output in High Z	--	--	25	--	--	30	ns
t_{AVQX}	t_{OH}	Data Hold from Address Change	10	--	--	10	--	--	ns

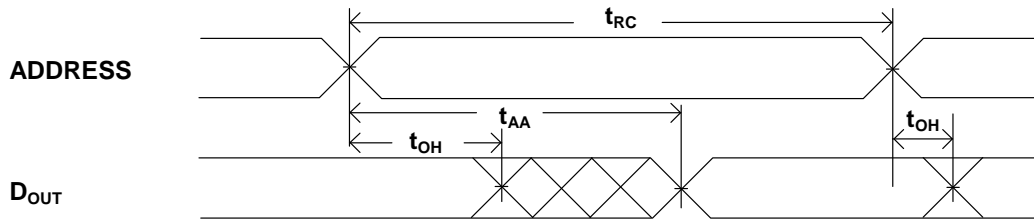
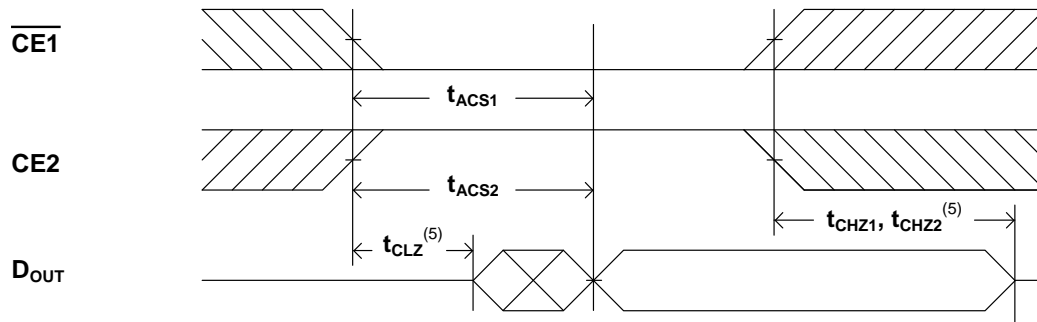
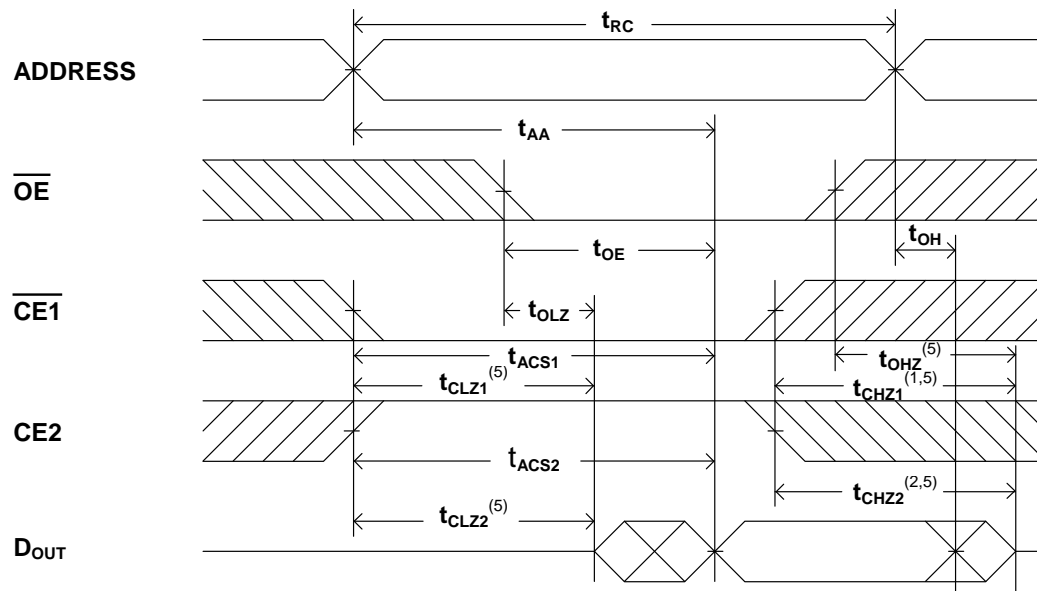
n SWITCHING WAVEFORMS (READ CYCLE)
READ CYCLE 1 ^(1,2,4)

READ CYCLE 2 ^(1,3,4)

READ CYCLE 3 ^(1,4)

NOTES:

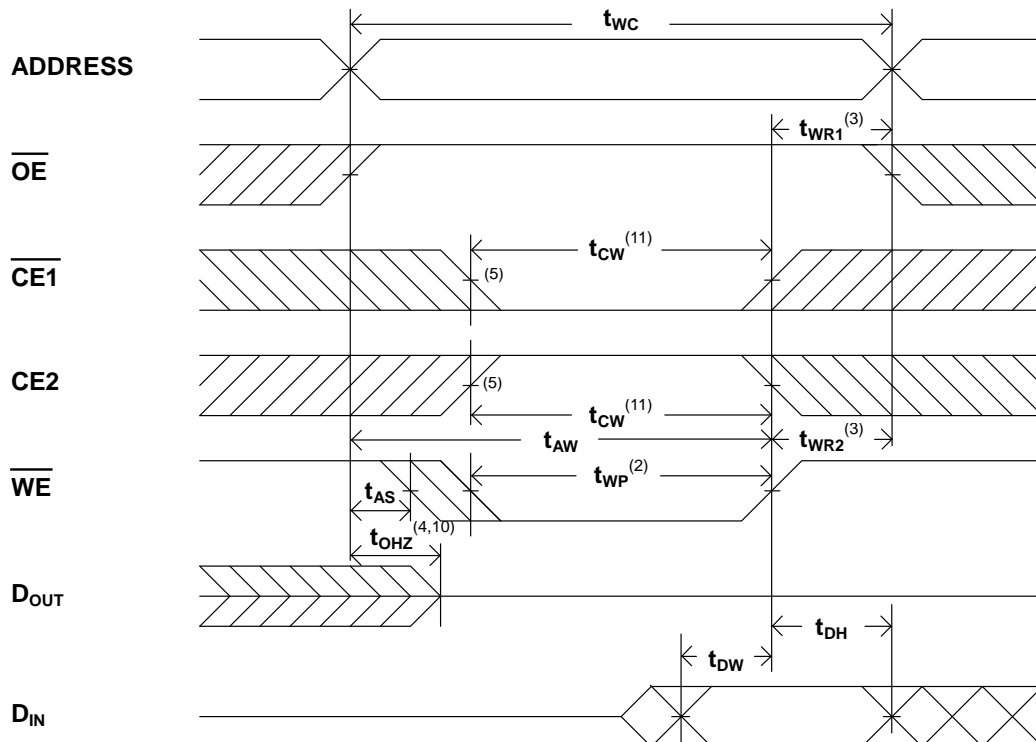
1. \overline{WE} is high in read Cycle.
2. Device is continuously selected when $\overline{CE1} = V_{IL}$ and $\overline{CE2} = V_{IH}$.
3. Address valid prior to or coincident with $\overline{CE1}$ transition low and/or $\overline{CE2}$ transition high.
4. $\overline{OE} = V_{IL}$.
5. Transition is measured $\pm 500\text{mV}$ from steady state with $C_L = 5\text{pF}$.
The parameter is guaranteed but not 100% tested.

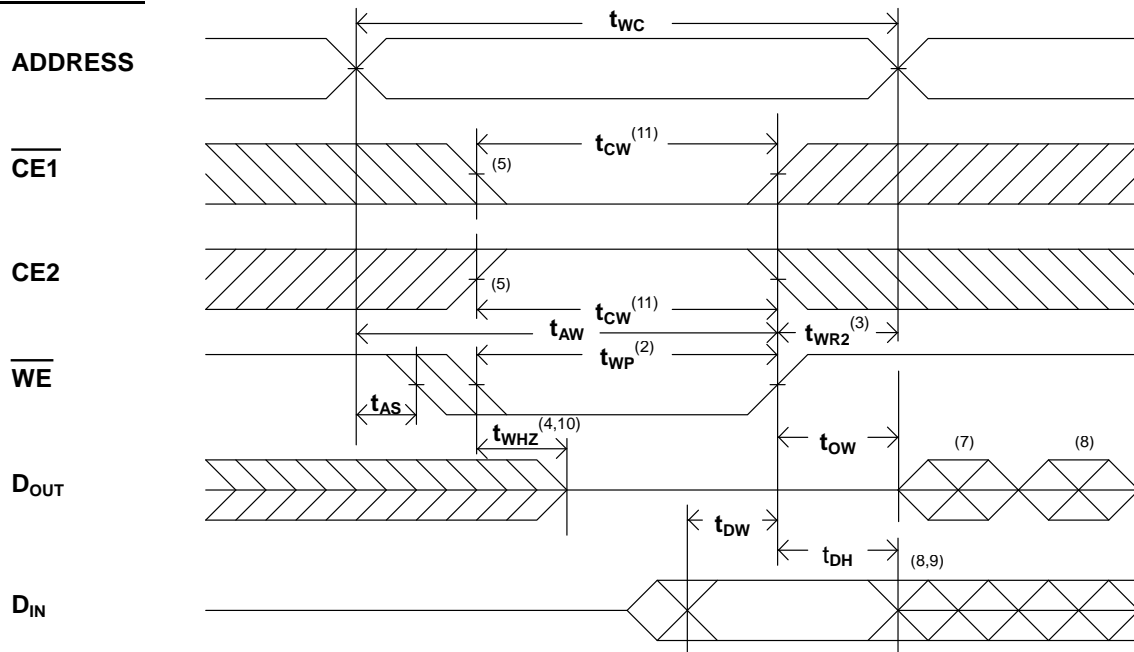
n AC ELECTRICAL CHARACTERISTICS (T_A = -40°C to +85°C)
WRITE CYCLE

JEDEC PARAMETER NAME	PARAMETER NAME	DESCRIPTION	CYCLE TIME : 55ns (V _{CC} = 3.0~5.5V)			CYCLE TIME : 70ns (V _{CC} = 2.7~5.5V)			UNITS
			MIN.	TYP.	MAX.	MIN.	TYP.	MAX.	
t _{AVAX}	t _{wc}	Write Cycle Time	55	--	--	70	--	--	ns
t _{E1LWH}	t _{cw}	Chip Select to End of Write	55	--	--	70	--	--	ns
t _{AVWL}	t _{AS}	Address Set up Time	0	--	--	0	--	--	ns
t _{AVWH}	t _{AW}	Address Valid to End of Write	55	--	--	70	--	--	ns
t _{WLWH}	t _{WP}	Write Pulse Width	30	--	--	35	--	--	ns
t _{WHAX}	t _{WR1}	Write Recovery Time (CE1, WE)	0	--	--	0	--	--	ns
t _{E2LAX}	t _{WR2}	Write Recovery Time (CE2)	0	--	--	0	--	--	ns
t _{WLQZ}	t _{WHZ}	Write to Output in High Z	--	--	25	--	--	30	ns
t _{DVWH}	t _{DW}	Data to Write Time Overlap	25	--	--	30	--	--	ns
t _{WHDX}	t _{DH}	Data Hold from Write Time	0	--	--	0	--	--	ns
t _{GHQZ}	t _{OHZ}	Output Disable to Output in High Z	--	--	25	--	--	30	ns
t _{WHQX}	t _{ow}	End of Write to Output Active	5	--	--	5	--	--	ns

n SWITCHING WAVEFORMS (WRITE CYCLE)
WRITE CYCLE 1 ⁽¹⁾

WRITE CYCLE 2 ^(1,6)

NOTES:

1. \overline{WE} must be high during address transitions.
2. The internal write time of the memory is defined by the overlap of $\overline{CE1}$ and $\overline{CE2}$ active and \overline{WE} low. All signals must be active to initiate a write and any one signal can terminate a write by going inactive. The data input setup and hold timing should be referenced to the second transition edge of the signal that terminates the write.
3. t_{WR} is measured from the earlier of $\overline{CE1}$ or \overline{WE} going high or $\overline{CE2}$ going low at the end of write cycle.
4. During this period, DQ pins are in the output state so that the input signals of opposite phase to the outputs must not be applied.
5. If the $\overline{CE1}$ low transition or the $\overline{CE2}$ high transition occurs simultaneously with the \overline{WE} low transitions or after the \overline{WE} transition, output remain in a high impedance state.
6. \overline{OE} is continuously low ($\overline{OE} = V_{IL}$).
7. D_{OUT} is the same phase of write data of this write cycle.
8. D_{OUT} is the read data of next address.
9. If $\overline{CE1}$ is low and $\overline{CE2}$ is high during this period, DQ pins are in the output state. Then the data input signals of opposite phase to the outputs must not be applied to them.
10. Transition is measured $\pm 500\text{mV}$ from steady state with $C_L = 5\text{pF}$.
The parameter is guaranteed but not 100% tested.
11. t_{CW} is measured from the later of $\overline{CE1}$ going low or $\overline{CE2}$ going high to the end of write.

n ORDERING INFORMATION

BS62LV1027	X	X	Z	Y Y	
					SPEED 55: 55ns 70: 70ns
					PKG MATERIAL -: Normal G: Green, RoHS Compliant P: Pb free, RoHS Compliant
					GRADE C: +0°C ~ +70°C I: -40°C ~ +85°C
				PACKAGE D: DICE H: BGA-36-0608 P: PDIP S: SOP T: TSOP (8mm x 20mm) ST: Small TSOP (8mm x 13.4mm)	

Note:

BSI (Brilliance Semiconductor Inc.) assumes no responsibility for the application or use of any product or circuit described herein. BSI does not authorize its products for use as critical components in any application in which the failure of the BSI product may be expected to result in significant injury or death, including life-support systems and critical medical instruments.

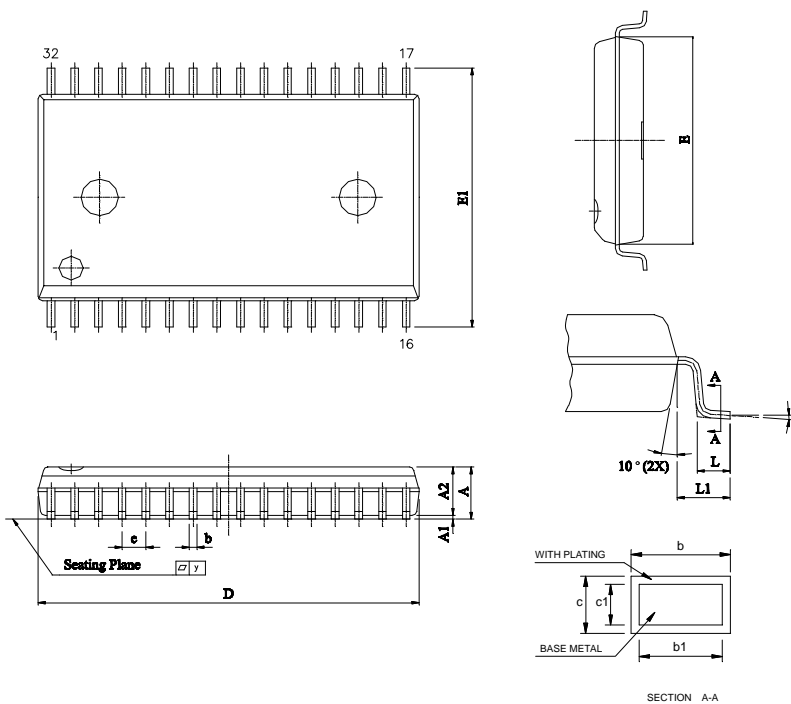
n PACKAGE DIMENSIONS

SOP-32

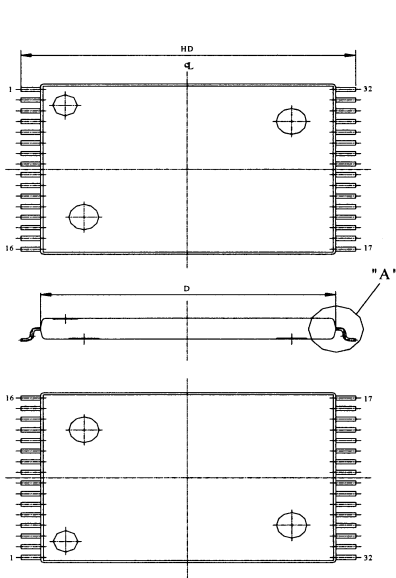
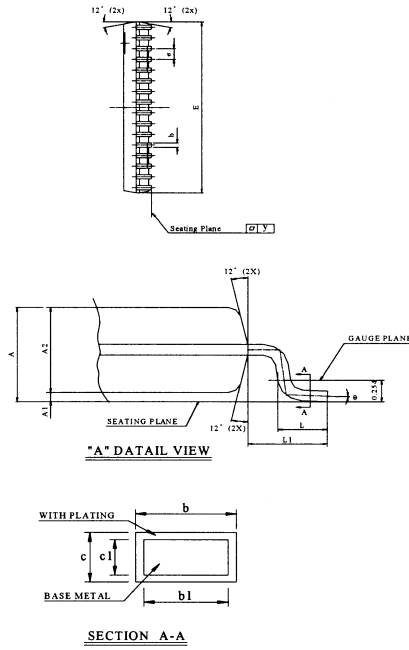
SYMBOL	UNIT	INCH	MM
A		0.111±0.007	2.821±0.176
A1		0.009±0.005	0.229±0.127
A2		0.1055±0.0055	2.680±0.140
b		0.014 ~ 0.020	0.35 ~ 0.50
b1		0.014 ~ 0.018	0.35 ~ 0.46
c		0.006 ~ 0.012	0.15 ~ 0.32
c1		0.006 ~ 0.011	0.15 ~ 0.28
D		0.805±0.005	20.447±0.127
E		0.445±0.005	11.303±0.127
E1		0.555±0.012	14.097±0.305
e		0.050±0.006	1.270±0.152
L		0.033±0.010	0.834±0.25
L1		0.055±0.008	1.397±0.203
y		0.004 Max.	0.1 Max.
θ		0° ~ 10°	0° ~ 10°

n PACKAGE DIMENSIONS (continued)

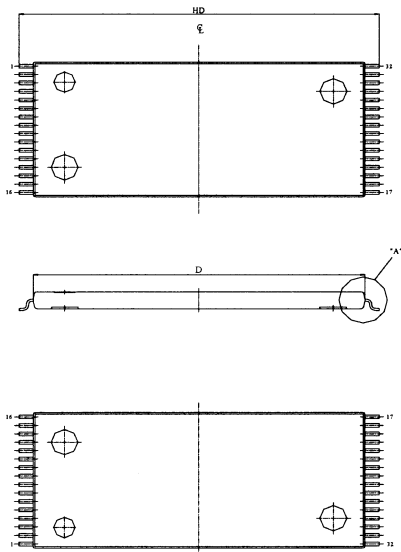
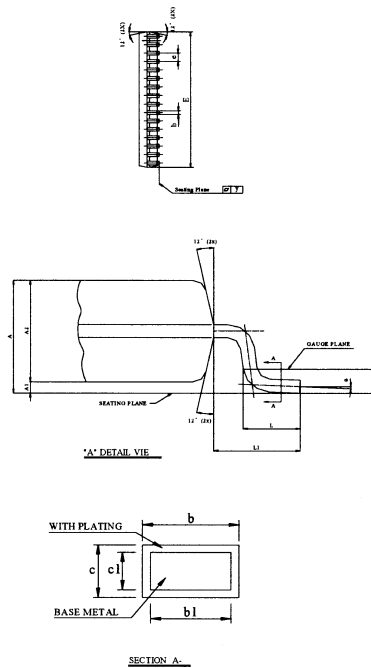
STSOP - 32

UNIT SYMBOL	INCH	MM
A	0.0433± 0.004	1.10± 0.10
A1	0.004± 0.002	0.10± 0.05
A2	0.039± 0.002	1.00± 0.05
b	0.009± 0.002	0.22± 0.05
b1	0.008± 0.001	0.20± 0.03
c	0.004 ~ 0.008	0.10 ~ 0.21
c1	0.004 ~ 0.006	0.10 ~ 0.16
D	0.465± 0.004	11.80± 0.10
E	0.315± 0.004	8.00± 0.10
e	0.020± 0.004	0.50± 0.10
HD	0.528± 0.008	13.40± 0.20
L	0.0197 ^{+0.008} / _{-0.004}	0.50 ^{+0.2} / _{-0.1}
L1	0.0315± 0.004	0.80± 0.10
y	0.004 Max.	0.1 Max.
θ	0° ~ 8°	0° ~ 8°

TSOP - 32

UNIT SYMBOL	INCH	MM
A	0.0433± 0.004	1.10± 0.10
A1	0.004± 0.002	0.10± 0.05
A2	0.039± 0.002	1.00± 0.05
b	0.009± 0.002	0.22± 0.05
b1	0.008± 0.001	0.20± 0.03
c	0.004 ~ 0.008	0.10 ~ 0.21
c1	0.004 ~ 0.006	0.10 ~ 0.16
D	0.724± 0.004	18.40± 0.10
E	0.315± 0.004	8.00± 0.10
e	0.020± 0.004	0.50± 0.10
HD	0.787± 0.008	20.00± 0.20
L	0.0197 ^{+0.008} / _{-0.004}	0.50 ^{+0.2} / _{-0.1}
L1	0.0315± 0.004	0.80± 0.10
y	0.004 Max.	0.1 Max.
θ	0° ~ 8°	0° ~ 8°

PACKAGE DIMENSIONS (continued)

UNIT SYMBOL	INCH(BASE)	MM(REF)
A1	0.010(MIN)	0.254(MIN)
A2	0.154±0.005	3.912±0.127
B	0.018±0.005	0.457±0.127
B1	0.050±0.005	1.270±0.127
c	0.010±0.004	0.254±0.102
D	1.650±0.005	41.910±0.127
E	0.600±0.010	15.240±0.254
E1	0.544±0.004	13.818±0.102
e	0.100(TYP)	2.540(TYP)
eB	0.650±0.020	16.510±0.508
L	0.130±0.010	3.302±0.254
S	0.075±0.010	1.905±0.254
Q1	0.070±0.005	1.778±0.127

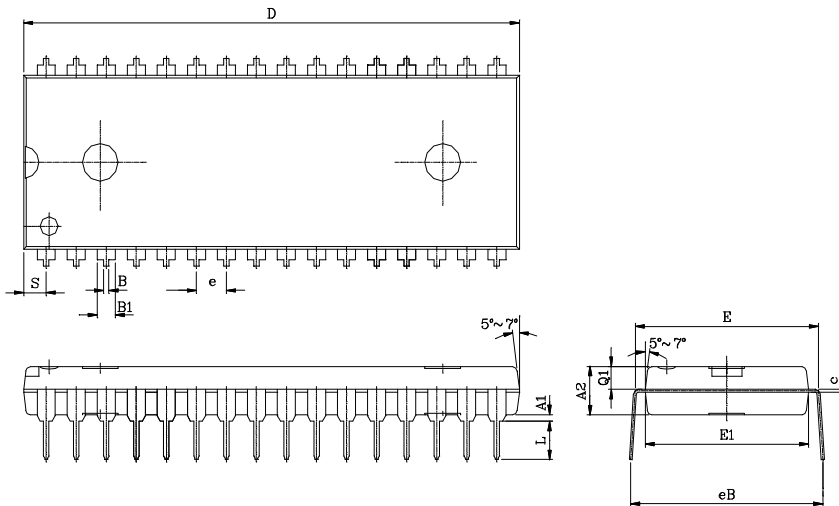
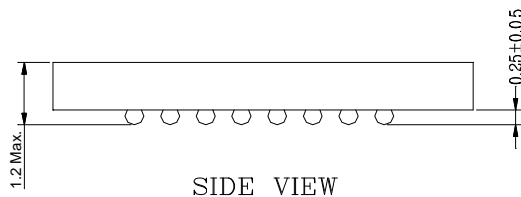
PDIP - 32

NOTES

- 1: CONTROLLING DIMENSIONS ARE IN MILLIMETERS.
- 2: PIN#1 DOT MARKING BY LASER OR PAD PRINT.
- 3: SYMBOL "N" IS THE NUMBER OF SOLDER BALLS.

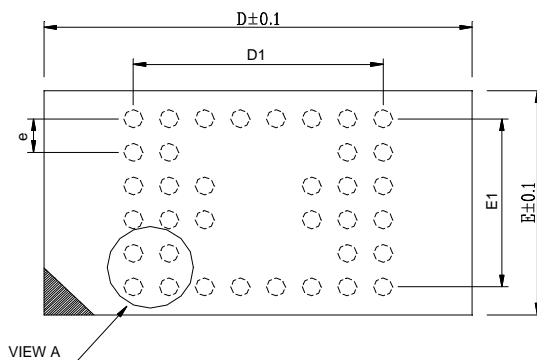
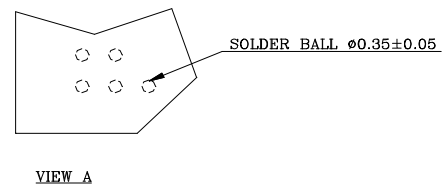
BALL PITCH e = 0.75				
D	E	N	D1	E1
8.0	6.0	48	5.25	3.75

TOP VIEW

36 mini-BGA (6 x 8mm)

n Revision History

<u>Revision No.</u>	<u>History</u>	<u>Draft Date</u>	<u>Remark</u>
2.2	Add Icc1 characteristic parameter Improve Iccsb1 spec. I-grade from 20uA to 5.0uA at 5.0V 2.5uA to 1.5uA at 3.0V C-grade from 8.0uA to 3.0uA at 5.0V 1.3uA to 1.0uA at 3.0V	Jan. 13, 2006	
2.3	Change I-grade operation temperature range - from -25°C to -40°C	May. 25, 2006	