



Am29833A/Am29853A

Parity Bus Transceivers

DISTINCTIVE CHARACTERISTICS

- High-speed bidirectional bus transceivers for processor organized devices
 - T-R delay = 6 ns typical
 - Ri-Parity delay = 9 ns typical
- Error flag with open-collector output
- Generates odd parity for all-zero protection
- 200 mV minimum input hysteresis (Commercial) on input data ports
- High drive capability:
 - 48 mA Commercial I_{OL}
- Higher speed, lower power versions of the Am29833 & Am29853

GENERAL DESCRIPTION

The Am29833A and Am29853A are high-performance parity bus transceivers designed for two-way communications. Each device can be used as an 8-bit transceiver, as well as a 9-bit parity checker/generator. In the transmit mode, data is read at the R port and output at the T port with a parity bit. In the receive mode, data and parity are read at the T port, and the data is output at the R port along with an ERR flag showing the result of the parity test.

In the Am29833A, the error flag is clocked and stored in a register which is read at the open-collector \overline{ERR} output. The \overline{CLR} input is used to clear the error flag register. In the Am29853A, a latch replaces this register, and the \overline{EN} and \overline{CLR} controls are used to pass, store, sample or clear the error flag output. When both output enables

are disabled in the Am29853A and Am29833A, the parity logic defaults to the transmit mode, so that the \overline{ERR} pin reflects the parity of the R port.

The output enables, \overline{OER} and \overline{OET} , are used to force the port outputs to the high-impedance state so that other devices can drive bus lines directly. In addition, the user can force a parity error by enabling both \overline{OER} and \overline{OET} simultaneously. This transmission of inverted parity gives the designer more system diagnostic capability.

Each of these devices is produced with AMD's proprietary IMOX™ bipolar process, and features typical propagation delays of 6 ns, as well as high-capacitive drive capability.

SIMPLIFIED BLOCK DIAGRAM

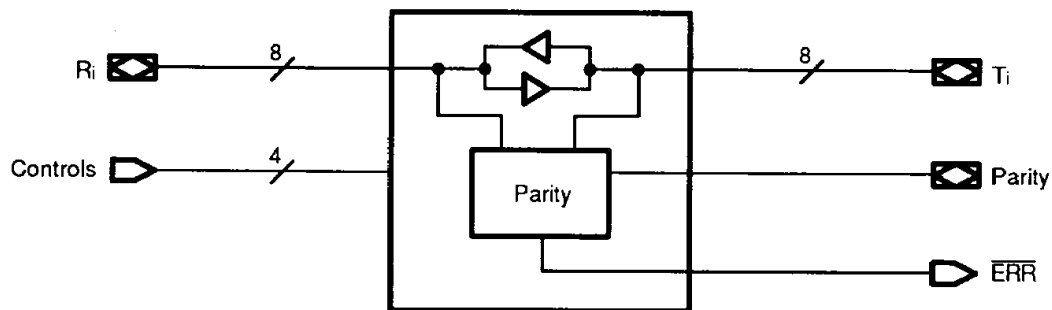

07140-001A

BLOCK DIAGRAMS
Am29833A

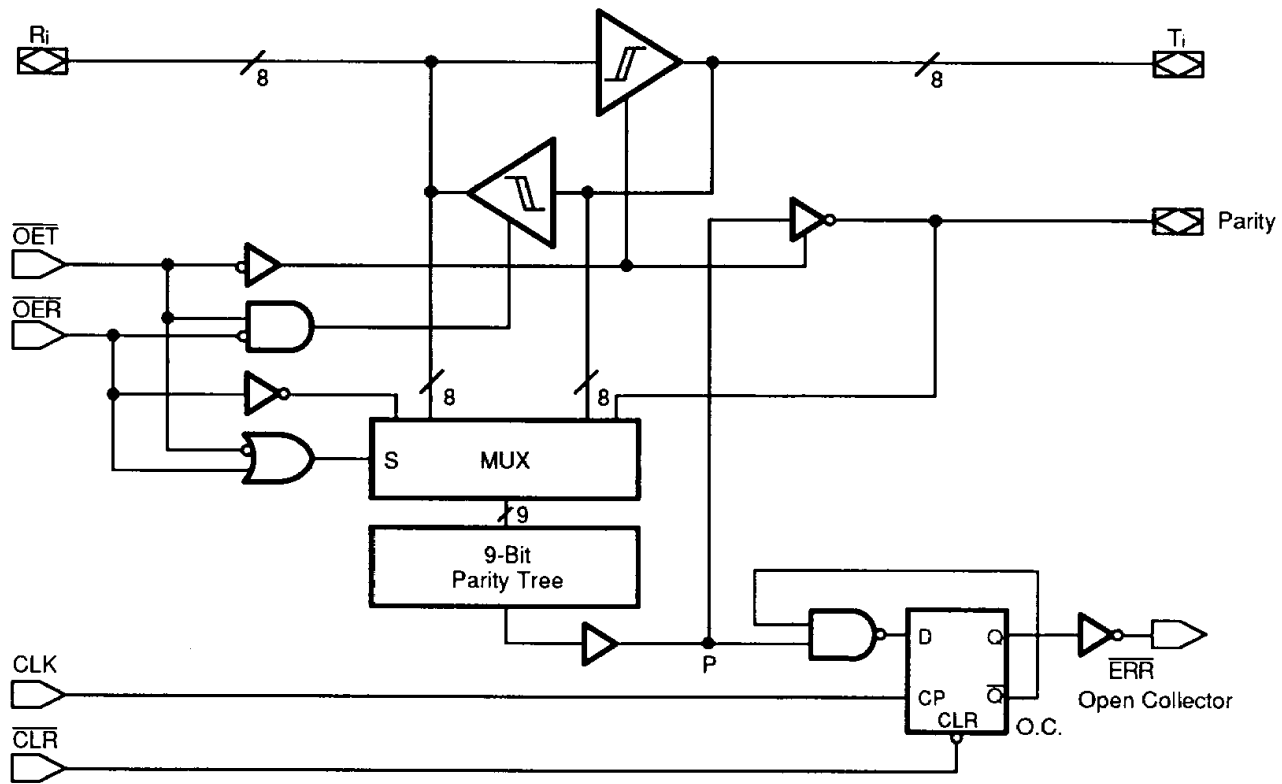

07140-002A

Am29853A

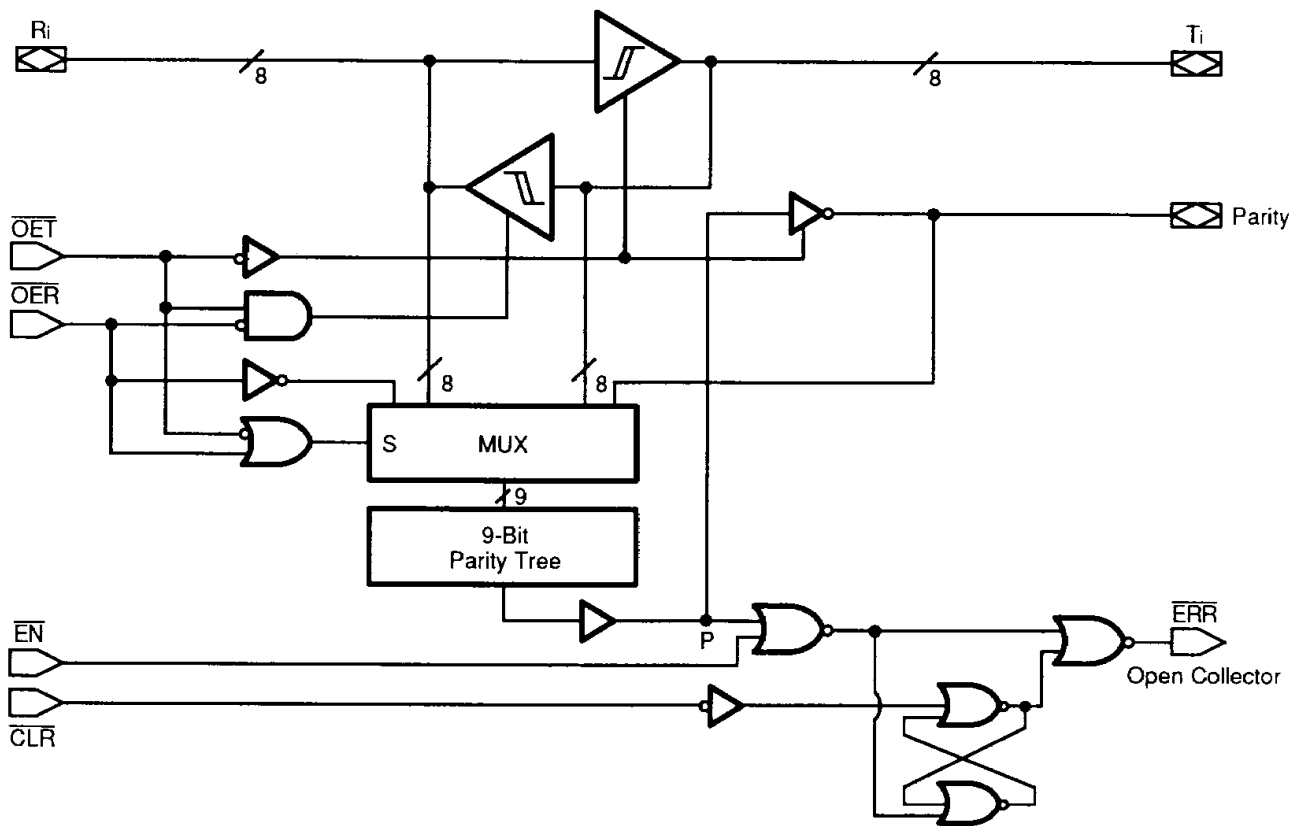

07140-003A

CONNECTION DIAGRAMS
(Top View)

Am29833A

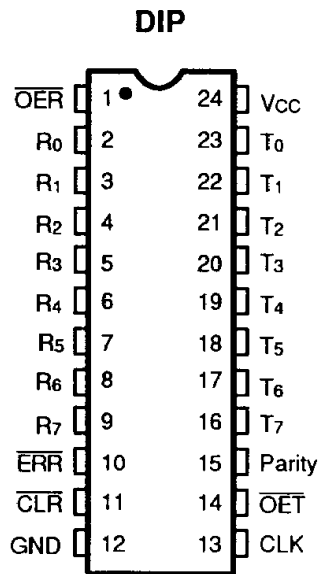

07140-004A

Am29853A

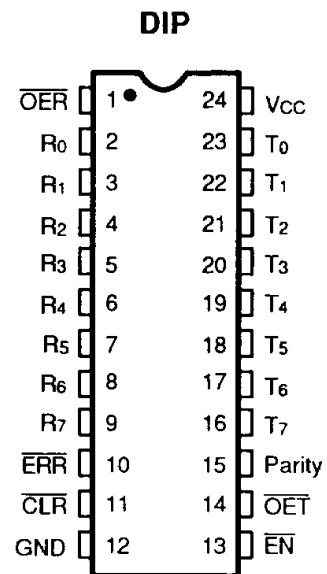

07140-005A

FUNCTION TABLE
Am29833A (Register Option)

Inputs								Outputs				Function
\overline{OET}	\overline{OER}	\overline{CLR}	CLK	R _i	Sum of H's of R _i	T _i	Sum of H's (T _i + Parity)	R _i	T _i	Parity	\overline{ERR}	
L	H	X	X	H	ODD	NA	NA	NA	H	L	NA	Transmit mode: transmits data from R port to T port, generating parity. Receive path is disabled.
L	H	X	X	H	EVEN	NA	NA	NA	H	H	NA	
L	H	X	X	L	ODD	NA	NA	NA	L	L	NA	
L	H	X	X	L	EVEN	NA	NA	NA	L	H	NA	
H	L	H	↑	NA	NA	H	ODD	H	NA	NA	H	Receive mode: transmits data from T port to R port with parity test resulting in error flag. Transmit path is disabled.
H	L	H	↑	NA	NA	H	EVEN	H	NA	NA	L	
H	L	H	↑	NA	NA	L	ODD	L	NA	NA	H	
H	L	H	↑	NA	NA	L	EVEN	L	NA	NA	L	
X	X	L	X	X	X	X	X	X	X	X	H	Clear error flag register.
H	H	H	X	X	X	X	X	Z	Z	Z	*	Both transmitting and receiving paths are disabled.
H	H	L	X	X	X	X	X	Z	Z	Z	H	
H	H	H	↑	L	ODD	X	X	Z	Z	Z	H	Parity logic defaults to transmit mode. Forced-error checking.
H	H	H	↑	H	EVEN	X	X	Z	Z	Z	L	
L	L	X	X	H	ODD	NA	NA	NA	H	H	NA	
L	L	X	X	H	EVEN	NA	NA	NA	H	L	NA	
L	L	X	X	L	ODD	NA	NA	NA	L	H	NA	
L	L	X	X	L	EVEN	NA	NA	NA	L	L	NA	

H = HIGH

L = LOW

↑ = LOW-to-HIGH Transition

X = Don't Care

Z = High Impedance

NA= Not Applicable

* = Store the State of the Last Receive Cycle

ODD = Odd Number

EVEN= Even Number

i = 0, 1, 2, 3, 4, 5, 6, 7

FUNCTION TABLE
Am29853A (Latch Option)

Inputs								Outputs				Function
\overline{OET}	\overline{OER}	\overline{CLR}	\overline{EN}	R _i	Sum of H's of R _i	T _i	Sum of H's (T _i + Parity)	R _i	T _i	Parity	\overline{ERR}	
L	H	X	X	H	ODD	NA	NA	NA	H	L	NA	Transmit mode: transmits data from R port to T port, generating parity. Receive path is disabled.
L	H	X	X	H	EVEN	NA	NA	NA	H	H	NA	
L	H	X	X	L	ODD	NA	NA	NA	L	L	NA	
L	H	X	X	L	EVEN	NA	NA	NA	L	H	NA	
H	L	L	L	NA	NA	H	ODD	H	NA	NA	H	Receive mode: transmits data from T port to R port with parity test resulting in error flag. Transmit path is disabled.
H	L	L	L	NA	NA	H	EVEN	H	NA	NA	L	
H	L	L	L	NA	NA	L	ODD	L	NA	NA	H	
H	L	L	L	NA	NA	L	EVEN	L	NA	NA	L	
H	L	H	L	NA	NA	H	ODD	H	NA	NA	H	Receive mode: transmits data from T port to R port, passes parity test resulting in error flag. Transmit path is disabled.
H	L	H	L	NA	NA	H	EVEN	H	NA	NA	L	
H	L	H	L	NA	NA	L	ODD	L	NA	NA	H	
H	L	H	L	NA	NA	L	EVEN	L	NA	NA	L	
H	L	H	H	NA	NA	X	X	X	NA	NA	*	Store the state of error flag latch.
X	X	L	H	X	X	X	X	X	NA	NA	H	Clear error flag latch.
H	H	H	H	X	X	X	X	Z	Z	Z	*	Both transmitting and receiving paths are disabled. Parity logic defaults to transmit mode.
H	H	L	H	X	X	X	X	Z	Z	Z	H	
H	H	X	L	L	ODD	X	X	Z	Z	Z	H	
H	H	X	L	H	EVEN	X	X	Z	Z	Z	L	
L	L	X	X	H	ODD	NA	NA	NA	H	H	NA	Forced-error checking.
L	L	X	X	H	EVEN	NA	NA	NA	H	L	NA	
L	L	X	X	L	ODD	NA	NA	NA	L	H	NA	
L	L	X	X	L	EVEN	NA	NA	NA	L	L	NA	

H = HIGH

L = LOW

↑ = LOW-to-HIGH Transition

X = Don't Care

Z = High Impedance

NA = Not Applicable

* = Store the State of the Last Receive Cycle

ODD = Odd Number

EVEN = Even Number

i = 0, 1, 2, 3, 4, 5, 6, 7

TRUTH TABLES
Error Flag Output
Am29833A

Inputs		Internal to Device	Outputs Pre-state	Output	Function
CLR	CLK	Point "P"	\overline{ERR}_{n-1}	\overline{ERR}	
H	↑	H	H	H	Sample (1's Capture)
H	↑	X	L	L	
H	↑	L	X	L	
L	X	X	X	H	Clear

Note:

\overline{OET} is HIGH and \overline{OER} is LOW.

Am29853A

Inputs		Internal to Device	Outputs Pre-state	Output	Function
\overline{EN}	\overline{CLR}	Point "P"	\overline{ERR}_{n-1}	\overline{ERR}	
L	L	L	X	L	Pass
L	L	H	X	H	
L	H	L	X	L	Sample (1's Capture)
L	H	X	L	L	
L	H	H	H	H	
H	L	X	X	H	Clear
H	H	X	L	L	Store
H	H	X	H	H	

Note:

\overline{OET} is HIGH and \overline{OER} is LOW.

ORDERING INFORMATION

Standard Products

AMD standard products are available in several packages and operating ranges. The order number (Valid Combination) is formed by a combination of:

- a. Device Number
- b. Speed Option (if applicable)
- c. Package Type
- d. Temperature Range
- e. Optional Processing

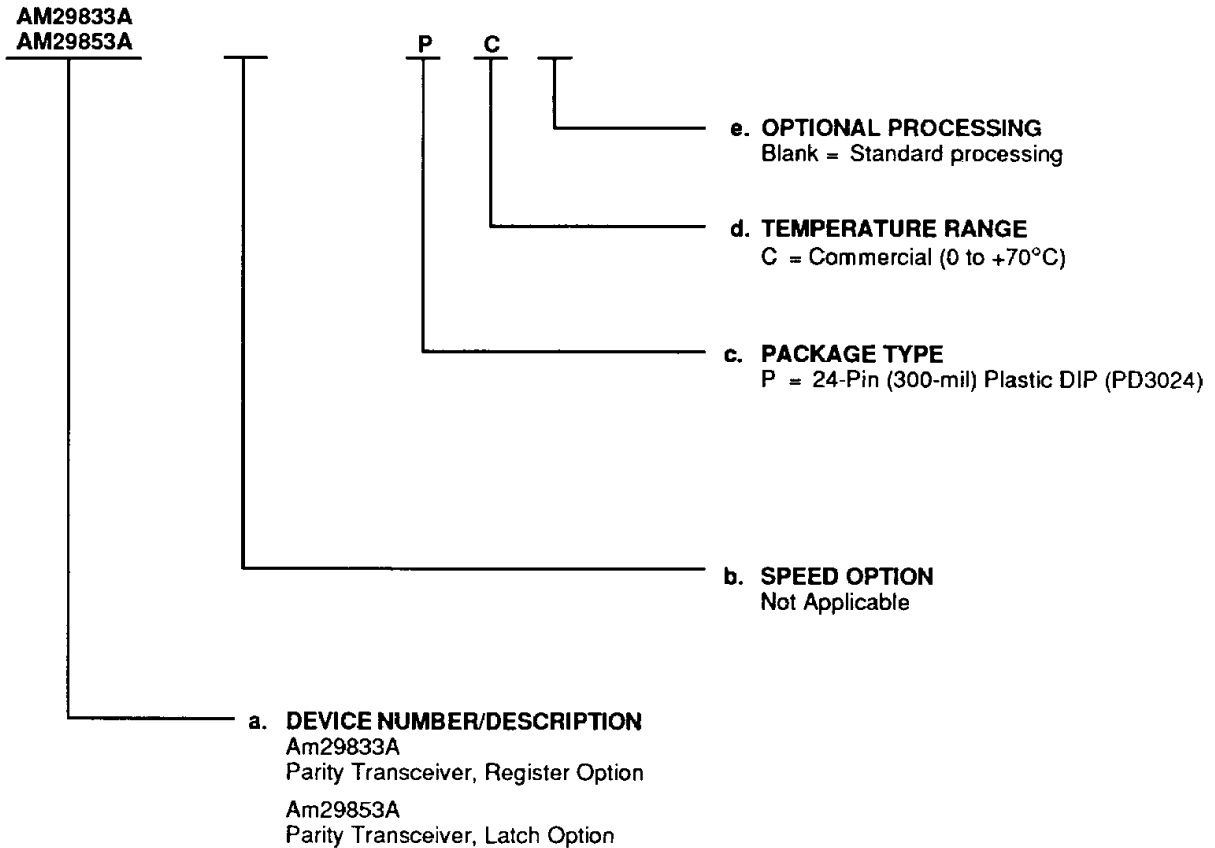

Valid Combinations	
AM29833A	PC
AM29853A	

Valid Combinations

Valid Combinations list configurations planned to be supported in volume for this device. Consult the local AMD sales office to confirm availability of specific valid combinations or to check on newly released combinations, and to obtain additional data on AMD's standard military grade products.

PIN DESCRIPTION

Am29833A/Am29853A

$\overline{\text{OER}}$

Output Enable Receive (Input, Active LOW)

When LOW in conjunction with $\overline{\text{OET}}$ HIGH, the devices are in the Receive mode (R_i are outputs, T_i and Parity are inputs).

$\overline{\text{OET}}$

Output Enable Transmit (Input, Active LOW)

When LOW in conjunction with $\overline{\text{OER}}$ HIGH, the devices are in the Transmit mode (R_i are inputs, T_i and Parity are outputs).

R_i

Receive Port (Input/Output, Three-State)

R_i are the 8-bit data inputs in the Transmit mode, and the outputs in the Receive mode.

T_i

Transmit Port (Input/Output, Three-State)

T_i are the 8-bit data outputs in the Transmit mode, and the inputs in the Receive mode.

Parity

Parity Flag (Input/Output, Three-State)

In the Transmit mode, the Parity signal is an active output used to generate odd parity. In the Receive mode, the T_i and Parity inputs are combined and checked for odd parity. When both output enables are HIGH, the Parity Flag is in the high impedance state. When both output enables are LOW, the Parity bit forces a parity error.

Am29833A Only

$\overline{\text{ERR}}$

Error Flag (Output, Open Collector)

In the Receive mode, the parity of the T_i bits is calculated and compared to the Parity input. $\overline{\text{ERR}}$ goes LOW when the comparison indicates a parity error. $\overline{\text{ERR}}$ stays LOW until the register is cleared.

$\overline{\text{CLR}}$

Clear (Input, Active LOW)

When $\overline{\text{CLR}}$ goes LOW, the Error Flag Register is cleared ($\overline{\text{ERR}}$ goes HIGH).

CLK

Clock (Input, Positive Edge-Triggered)

This pin is the clock input for the Error Flag register.

Am29853A Only

$\overline{\text{ERR}}$

Error Flag (Output, Open Collector)

In the Receive mode, the parity of the T_i bits is calculated and compared to the Parity input. $\overline{\text{ERR}}$ goes LOW when the comparison indicates a parity error. $\overline{\text{ERR}}$ stays LOW until the latch is cleared.

$\overline{\text{CLR}}$

Clear (Input, Active LOW)

When $\overline{\text{CLR}}$ goes LOW, and $\overline{\text{EN}}$ is HIGH, the Error Flag latch is cleared ($\overline{\text{ERR}}$ goes HIGH).

$\overline{\text{EN}}$

Latch Enable (Input, Active LOW)

This pin is the latch enable for the Error Flag latch.

ABSOLUTE MAXIMUM RATINGS

Storage Temperature	-65°C to +150°C
Ambient Temperature with Power Applied	-55 to +125°C
Supply Voltage to Ground Potential Continuous	-0.5 V to +7.0 V
DC Voltage Applied to Outputs For High Output State	-0.5 V to +5.5 V
DC Input Voltage	-1.5 V to +6.0 V
DC Output Current, Into Outputs	100 mA
DC Input Current	-30 mA to +5.0 mA

OPERATING RANGES

Commercial (C) Devices

Ambient Temperature (T _A)	0 to +70°C
Supply Voltage (V _{CC})	+4.5 to +5.5 V

Operating ranges define those limits between which the functionality of the device is guaranteed.

Stresses above those listed under Absolute Maximum Ratings may cause permanent device failure. Functionality at or above these limits is not implied. Exposure to absolute maximum ratings for extended periods may affect device reliability.

DC CHARACTERISTICS over operating range unless otherwise specified

Parameter Symbol	Parameter Description	Test Conditions		Min.	Max.	Unit	
V _{OH}	Output HIGH Voltage Except ($\overline{\text{ERR}}$)	V _{CC} = 4.5 V, V _{IN} = V _{IH} or V _{IL}	I _{OH} = -15 mA	2.4		V	
			I _{OH} = -24 mA	2.0			
V _{OL}	Output LOW Voltage	V _{CC} = 4.5 V, V _{IN} = V _{IH} or V _{IL}	$\overline{\text{ERR}}$		0.5	V	
			All Other Outputs	I _{OL} = 48 mA		0.5	V
V _{IH}	Input HIGH Voltage	Guaranteed Input Logical HIGH Voltage for all inputs (Note 1)			2.0		V
V _{IL}	Input LOW Voltage	Guaranteed Input Logical LOW Voltage for all inputs (Note 1)				0.8	V
V _I	Input Clamp Voltage	V _{CC} = 4.5 V, I _{IN} = -18 mA				-1.2	V
V _{HYST}	Hysteresis for Inputs R _i , T _i				200		mV
I _{ZL}	I/O Port LOW Current	V _{CC} = 5.5 V, V _{IN} = 0.4 V				-550	μA
I _{IL}	Input LOW Current	V _{CC} = 5.5 V, V _{IN} = 0.4 V				-0.5	mA
I _{IH}	Input HIGH Current	V _{CC} = 5.5 V, V _{IN} = 2.7 V				50	μA
I _I	Input HIGH Current	V _{CC} = 5.5 V, V _{IN} = 5.5 V				100	μA
I _{ZH}	I/O Port HIGH Current	V _{CC} = 5.5 V, V _{IN} = 2.7 V				100	μA
I _{ZI}	I/O Port HIGH Current	V _{CC} = 5.5 V, V _{IN} = 5.5 V				150	μA
I _{SC}	Output Short-Circuit Current	V _{CC} = 5.5 V, V _O = 0 V (Note 2)			-75	-250	mA
I _{OFF}	Bus Leakage Current	V _{CC} = 0 V, V _O = 2.9 V				100	μA
I _{CC}	Power Supply Current	V _{CC} = 5.5 V Outputs Loaded	Outputs LOW		180	mA	
			Outputs HIGH		155		
			Outputs Hi-Z		170		

Notes:

- Input thresholds are tested during DC parameter testing, and may be tested in combination with other DC parameters.
- Not more than one output shorted at a time. Duration of the short-circuit test should not exceed one second.

SWITCHING CHARACTERISTICS over operating ranges unless otherwise specified

Parameter Symbol	Parameter Description	Test Conditions*	Min.	Max.	Unit	
t _{PLH}	Propagation Delay to R _i to T _i ,	C _L = 50 pF R ₁ = 500 Ω R ₂ = 500 Ω		10	ns	
t _{PHL}	T _i to R _i			10	ns	
t _{PLH}	Propagation Delay R _i to Parity			15	ns	
t _{PHL}				15	ns	
t _{ZH}	Output Enable Time $\overline{\text{OER}}$, $\overline{\text{OET}}$ to R _i , T _i and Parity			12		ns
t _{ZL}					12	ns
t _{HZ}	Output Disable Time $\overline{\text{OER}}$, $\overline{\text{OET}}$ to R _i , T _i and Parity			12		ns
t _{LZ}					12	ns
t _s	T _i , Parity to CLK Setup Time (Note 1)			12		ns
t _H	T _i , Parity to CLK Hold Time (Note 1)			0		ns
t _{REC}	Clear ($\overline{\text{CLR}}$ ) to CLK Setup Time (Note 2)			15		ns
t _{PWH}	Clock Pulse Width (Note 1)		HIGH	7		ns
t _{PWL}			LOW	7		ns
t _{PWL}	Clear Pulse Width		LOW	7		ns
t _{PHL}	Propagation Delay CLK to $\overline{\text{ERR}}$ (Note 1)				12	ns
t _{PLH}	Propagation Delay $\overline{\text{CLR}}$ to $\overline{\text{ERR}}$				16	ns
t _{PLH}	Propagation Delay T _i , Parity to $\overline{\text{ERR}}$ (PASS Mode Only) Am29853A				22	ns
t _{PHL}					18	ns
t _{PLH}	Propagation Delay $\overline{\text{OER}}$ to Parity				15	ns
t _{PHL}					15	ns

*See test circuit and waveforms (Chapter 2).

Notes:

1. For Am29853A, replace CLK with $\overline{\text{EN}}$.
2. Not applicable to Am29853A.

PACKAGE OUTLINES*

T-90-20

PD3024

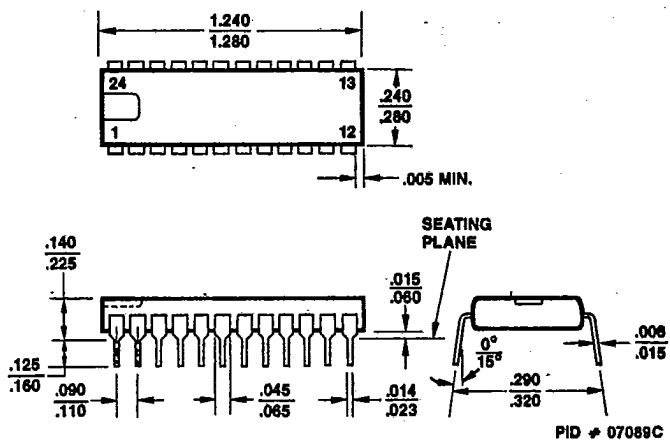

CD3024

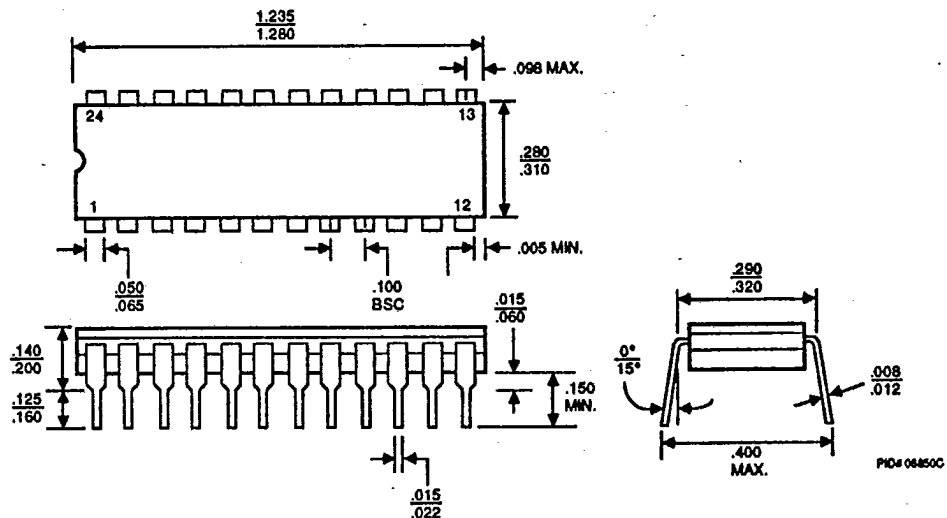

*For reference only.

PACKAGE OUTLINES (Cont'd.)

T-90-20

SO 024

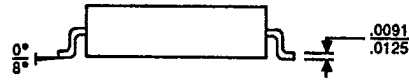
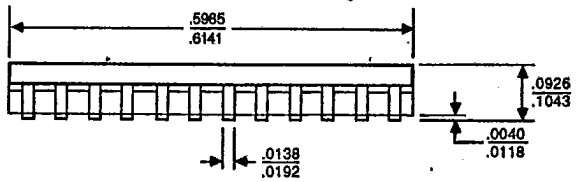
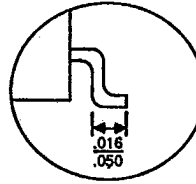
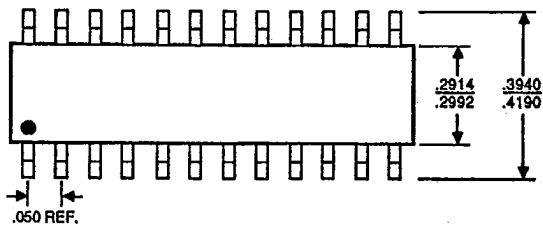

PD # 09310B

CFM024

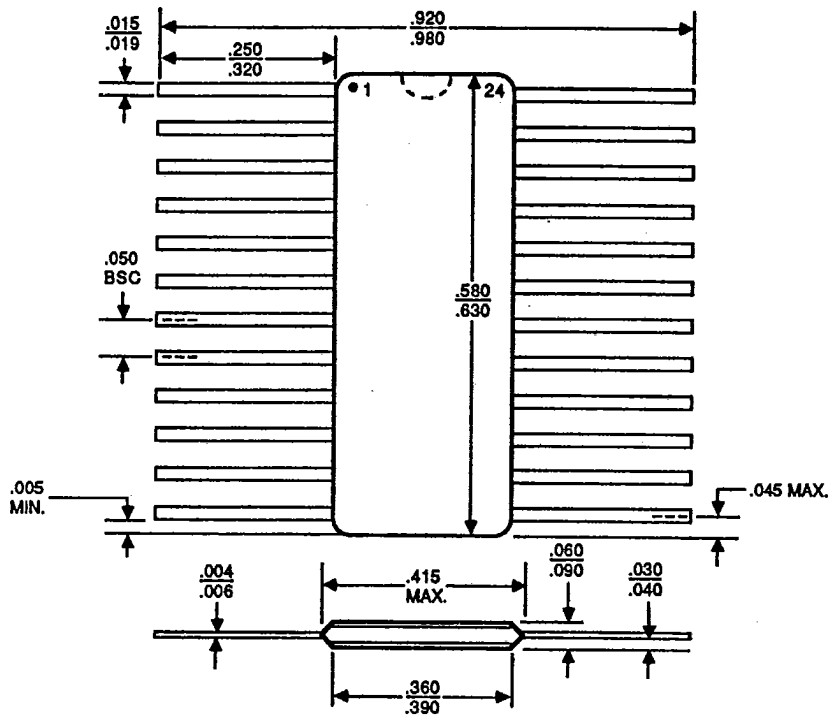

PD # 07371C

PACKAGE OUTLINES (Cont'd.)

T-90-20

PL 028

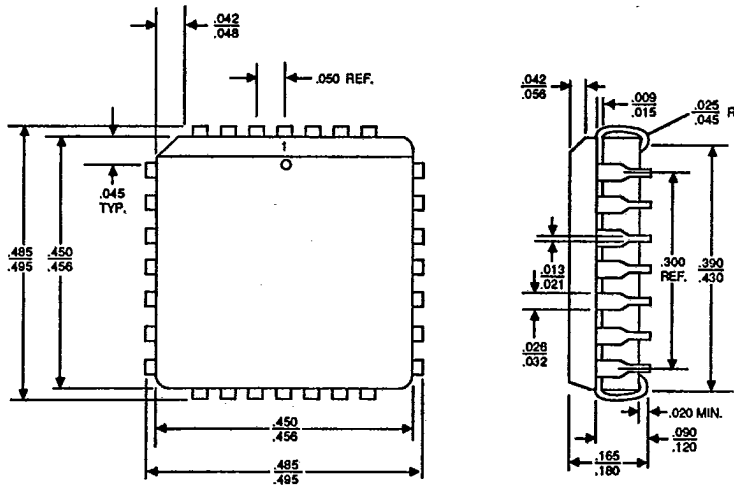

PID # 06751E

CL 028

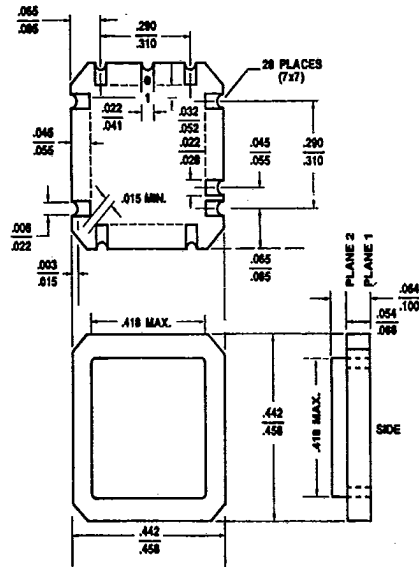

PID # 06596D

Advanced Micro Devices reserves the right to make changes in its product without notice in order to improve design or performance characteristics. The performance characteristics listed in this document are guaranteed by specific tests, correlated testing, guard banding, design and other practices common to the industry. For specific testing details, contact your local AMD sales representative. The company assumes no responsibility for the use of any circuits described herein.



ADVANCED MICRO DEVICES 901 Thompson Pl., P.O. Box 3453, Sunnyvale, CA 94088, USA
TEL: (408) 732-2400 • TWX: 910-339-9280 • TELEX: 34-6306 • TOLL FREE: (800) 538-8450

© 1988 Advanced Micro Devices, Inc.
Printed in U.S.A. AIS-WCP-20M-01/88-0

PD3024
24-Pin 300-mil Plastic SKINNYDIP

T-90-20

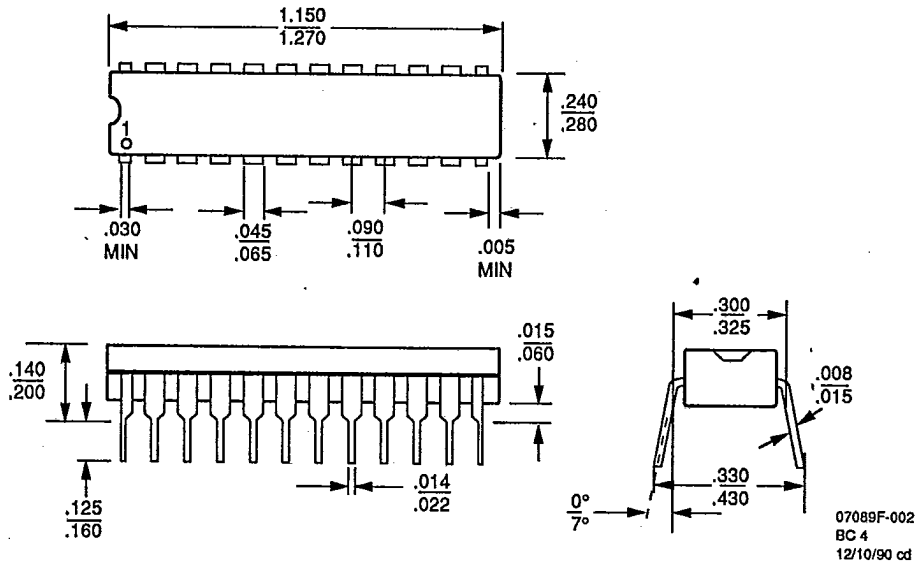

Note:
For reference only. All dimensions measured in inches. BSC is an ANSI standard for Basic Space Centering.

T-90-20

CD3024
24-Pin 300-mil Ceramic SKINNYDIP

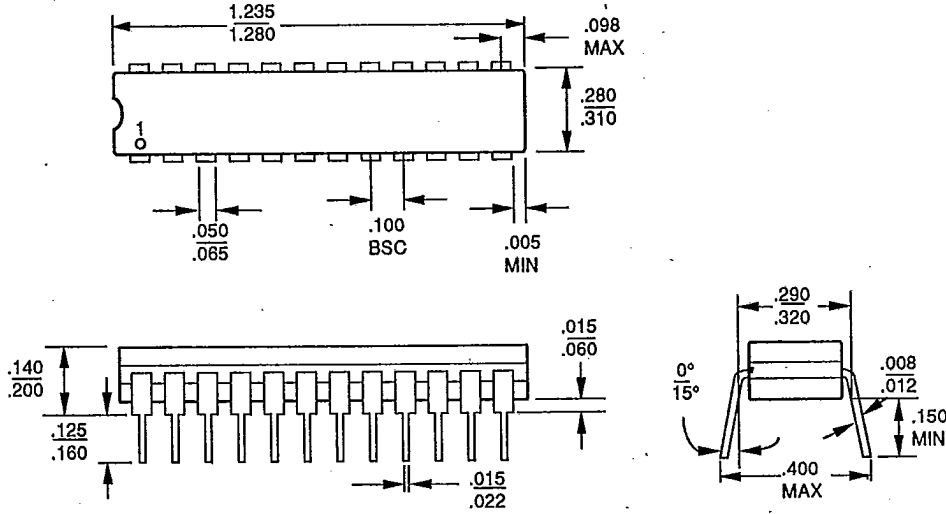

06850C

PL 028
28-Pin Plastic Leaded Chip Carrier

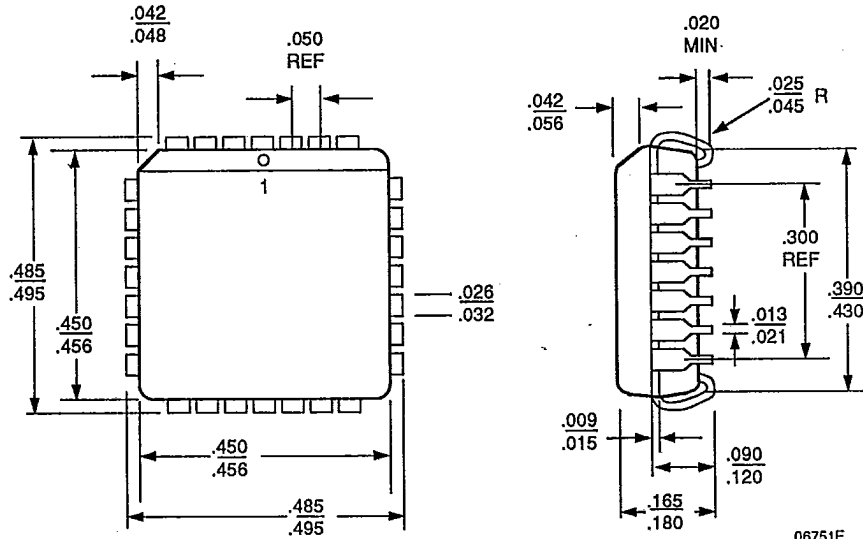

06751E

SO 024
24-Pin Plastic Small Outline Package

T-90-20

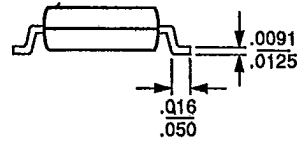
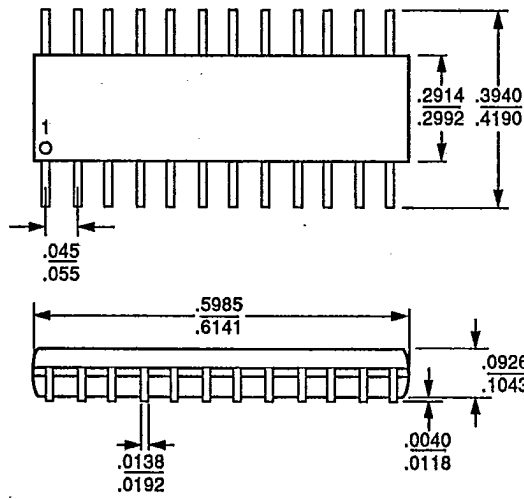

09310B