

Features

- Compatible with Microsoft Windows 2000 and 5-Button Wheel Mouse
- Compatible with Microsoft Intelli 3D PS/2 and IBM PS/2 mouse compatible
- Supports rolling buttons in 3D PS/2 mouse mode
- Supports five buttons (R,M,L,B4,B5) and three axes (X,Y,Z)input
- Z axis can support optomechanical and mechanical scroller input
- Crystal oscillator system frequency 6MHz for transmitter and 6MHz for receiver
- 27MHz Single Channel with 8 ID Code
- Transmitter 20-pin SOP and receiver 16-pin SOP package

General Description

The HT82M938T/HT82M938R is a Plug & Play 27MHz RF 5 Buttons 3D PS/2 mouse controller transmitter and receiver. It is compatible with Microsoft Intelli 3D PS/2

Wheel Mouse. The operation of the Z axis can support optomechanical and mechanical scroller input.

Pin Assignment

Transmitter

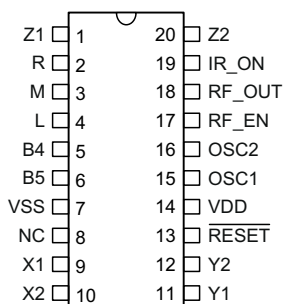

HT82M938T
- 20 SOP-A

Receiver

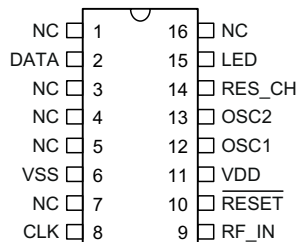

HT82M938R
- 16 SOP-A

Pin Description

Transmitter

Pin No.	Pin Name	I/O	Description
1, 20	Z1, Z2	I	Z-axis input supports two kinds of scroller input; optomechanical and mechanical.
2, 3, 4, 5, 6	R, M, L, B4, B5	I	Input ports with pull-high 12kΩ resistor. These pads can function as Left, Right, Middle, B4 and B5 button lines.
7	VSS	—	Negative power supply, ground
9, 10	X, X2	I	X-axis photo input
11, 12	Y1, Y2	I	Y-axis photo input
13	RESET	I	Chip reset input, low active
14	VDD	—	5V positive power supply
15	OSC1	I	6MHz OSC input
16	OSC2	O	6MHz OSC output

Pin No.	Pin Name	I/O	Description
17	RF_EN	O	RF module enable
18	RF_OUT	O	RF data output
19	IR_ON	O	X, Y, Z photo input power control

Receiver

Pin No.	Pin Name	I/O	Description
2	DATA	I/O	PS/2 mouse "DATA" line with pull-high 12kΩ resistor
6	VSS	—	Negative power supply, ground
8	CLK	I/O	PS/2 mouse "CLOCK" line with pull-high 12kΩ resistor
9	RF_IN	I	RF data input
10	RESET	I	Chip reset input, low active
11	VDD	—	5V positive power supply
12	OSC1	I	6MHz OSC input
13	OSC2	O	6MHz OSC output
14	RES_CH	I	Channel select reset switch with pull-high 12kΩ resistor
15	LED	O	Data transfer and change channel mode display LED

Electrical Characteristics
Transmitter

Symbol	Parameter	Test Conditions		Min.	Typ.	Max.	Unit
		V _{DD}	Conditions				
V _{DD}	Operating Voltage	—	—	2.4	—	5.5	V
I _{DD}	Operating Current (Crystal OSC)	3V	No load, f _{sys} =6MHz	—	0.7	1.5	mA
I _{STB}	Standby Current	3V	No load, system HALT	—	—	8	μA
V _{IL}	Input Low Voltage (X1, X2, Y1, Y2, Z1, Z2, R, M, L, B4, B5)	3V	—	0	—	1	V
V _{IH}	Input High Voltage (X1, X2, Y1, Y2, Z1, Z2, R, M, L, B4, B5)	3V	—	2.1	—	3	V
V _{IL1}	Input Low Voltage (RESET)	3V	—	0	—	0.7	V
V _{IH1}	Input High Voltage (RESET)	3V	—	2.5	—	3	V

Receiver

Symbol	Parameter	Test Conditions		Min.	Typ.	Max.	Unit
		V _{DD}	Conditions				
V _{DD}	Operating Voltage	—	—	2.4	—	5.5	V
I _{DD}	Operating Current (Crystal OSC)	5V	No load, f _{sys} =6MHz	—	2	5	mA
I _{STB}	Standby Current	5V	No load, system HALT	—	—	15	μA
V _{IL}	Input Low Voltage (RES_CH)	5V	—	0	—	1.5	V
V _{IH}	Input High Voltage (RES_CH)	5V	—	3.5	—	5	V
V _{IL1}	Input Low Voltage (RESET)	5V	—	0	—	1.3	V
V _{IH1}	Input High Voltage (RESET)	5V	—	4.1	—	5	V

Functional Description

Change ID procedure

- First press Receiver **RESET** key, the LED will blink very quickly.
- Now press Transmitter L, M, R button at least 3-minutes, the mouse will jump to change ID mode and output a change ID signal to the receiver.
- At the same time, the LED of the Receiver will blink slowly to wait the change ID information.
- The user can decide which ID to be changed by pressing M button. If the user wants to change ID to 4, just press the M button four time (This mouse support 8 ID).
- After deciding the ID number, the user can easy return to normal mode by pressing the L or R button once.
- After the Receiver receive the END signal of the change ID, the LED will no longer blink and the Receiver returns to normal mode.

PS/2 mouse

- PS/2 status byte
Bit
7: RESERVED
6: 0=STREAM MODE, 1=REMOTE MODE
5: 0=DISABLED, 1=ENABLED
4: 0=SCALING 1:1, 1=SCALING 2:1
3: RESERVED
2: 1=LEFT BUTTON PRESSED
1: 1=MIDDLE BUTTON PRESSED
0: 1=RIGHT BUTTON PRESSED
- Standard PS/2 data format
Variable rps, 0, 8, 1, bidirectional synchronous.

Bit No.	7	6	5	4	3	2	1	0
1st word	YV	XV	YS	XS	1	M	R	L
2nd word	X7	X6	X5	X4	X3	X2	X1	X0
3rd word	Y7	Y6	Y5	Y4	Y3	Y2	Y1	Y0

- Data format for 3D PS/2

Variable rps, 0, 8, 1, bidirectional synchronous.

Bit No.	7	6	5	4	3	2	1	0
1st word	YV	XV	YS	XS	1	M	R	L
2nd word	X7	X6	X5	X4	X3	X2	X1	X0
3rd word	Y7	Y6	Y5	Y4	Y3	Y2	Y1	Y0
4th word	Z7	Z6	Z5	Z4	Z3	Z2	Z1	Z0

Note: The X/Y data report is 9-bit 2's complement

The Z data report is 8-bit 2's complement

X movement towards the right is positive, movement towards the left is negative

Y upward movement is positive, moving down is negative

Z rolling towards the user is positive, else negative

Button status: 1=pressed, 0=released

- Mouse mode changes between standard and 3D PS/2 mode

- Sending the commands in the following sequence will set the mouse to 3D PS/2 mode.

Command	Response from mouse
F3h	FAh
C8h	FAh
F3h	FAh
64h	FAh
F3h	FAh
50h	FAh
F2h	Fah

- Any time the PC sends a reset 'FFh' command to the mouse, it will reset the mouse to standard PS/2 mode.

- After power-on reset is initiated, the mouse is set to standard PS/2 mode.

5-button wheel mouse mode follows the 5-button activation method of Windows 2000 and 5-button wheel mouse specification.

Timing Diagrams

X, Y, Z input

- X, Y Axis photo-coupler cross width

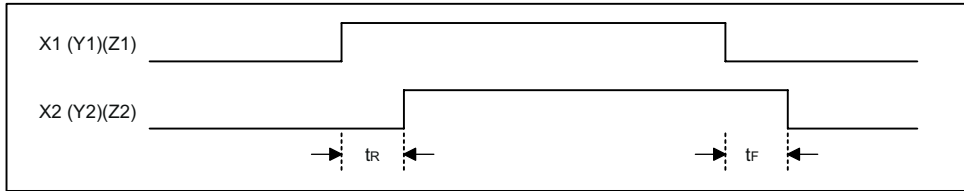

For X, Y-axis $t_R, t_F > 100\mu s$; For Z-axis $t_R, t_F > 1ms$

- X/Y/Z Axis counting

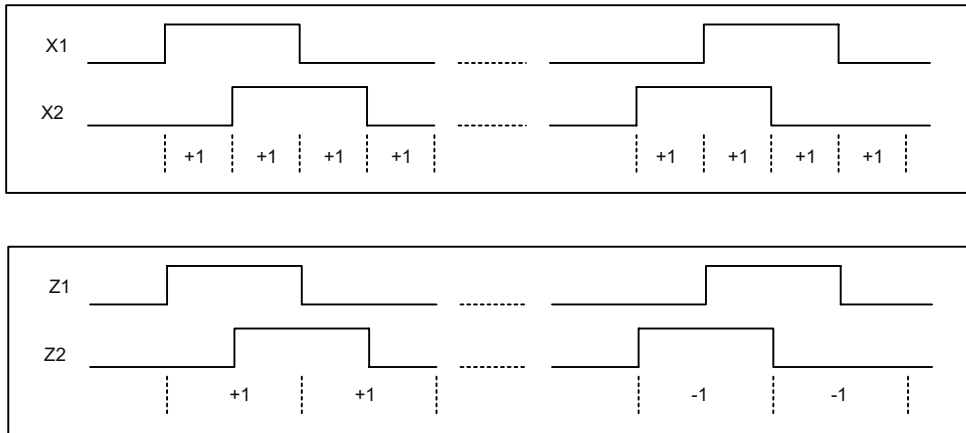

PS/2 mouse

- Data output

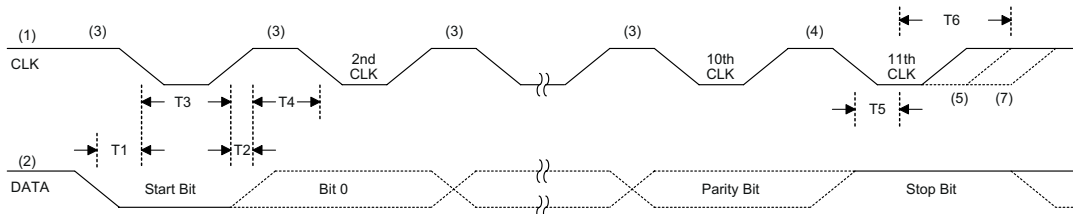

Timing Parameter	Min/Max
T1 Data transition to the falling edge of CLOCK	5/25 μsec
T2 Rising edge of CLOCK to DATA transition	5/T4-5 μsec
T3 Duration of CLOCK low	30/50 μsec
T4 Duration of CLOCK high	30/50 μsec
T5 Minimum time to MOUSE inhibit after clock 11	>0 μsec
T6 Maximum time to MOUSE inhibit after clock 11 to ensure MOUSE does not start another transmission	<50 μsec

• Data input

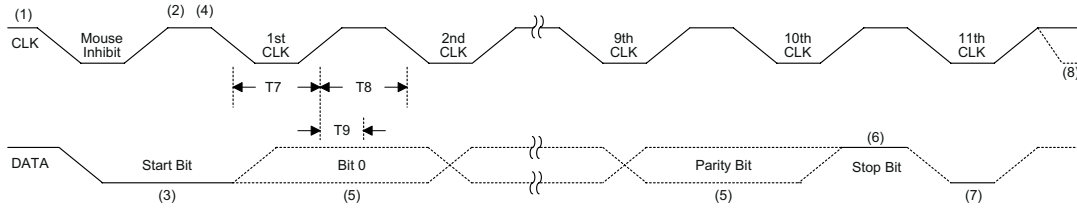

Timing Parameter

Min/Max

T7	Duration of CLOCK low	30/50 μ sec
T8	Duration of CLOCK high	30/50 μ sec
T9	Time from low to high CLOCK transition to time when MOUSE samples DATA line	5/25 μ sec

Application Circuits

Transmitter application (This application circuit is for reference only)

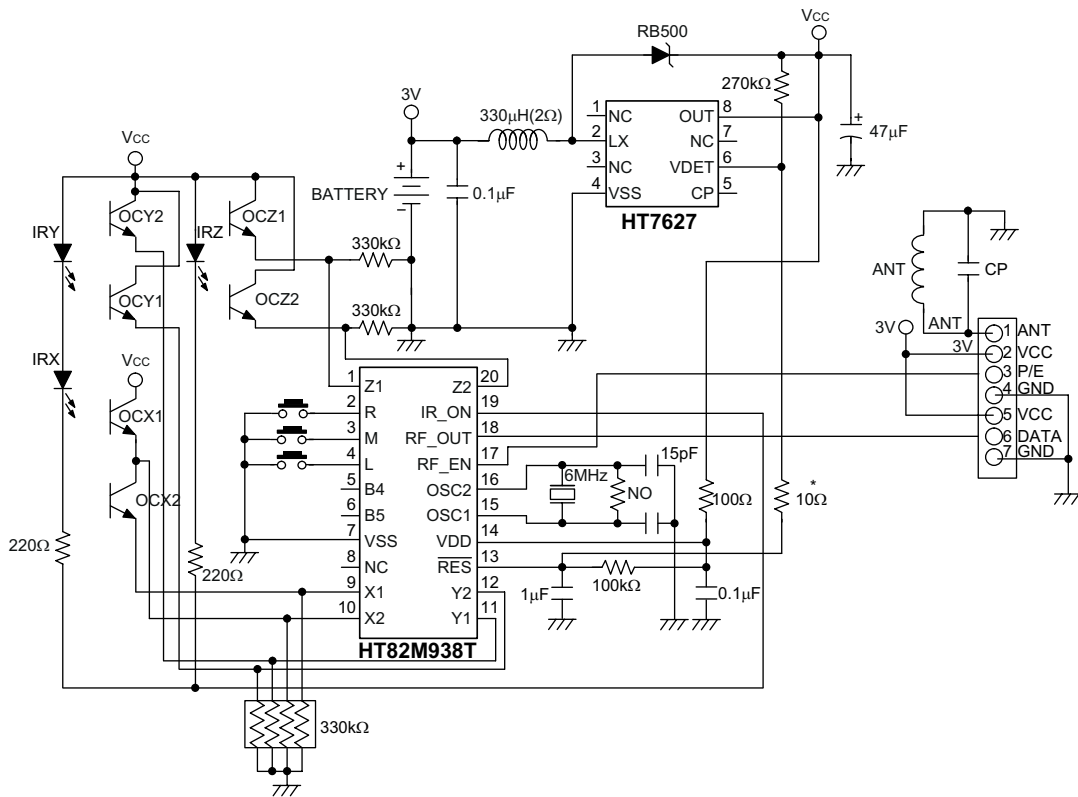

Note: * 10 Ω is placed if HT7627 is used to reset HT82M938T

Receiver application (This application circuit is for reference only)

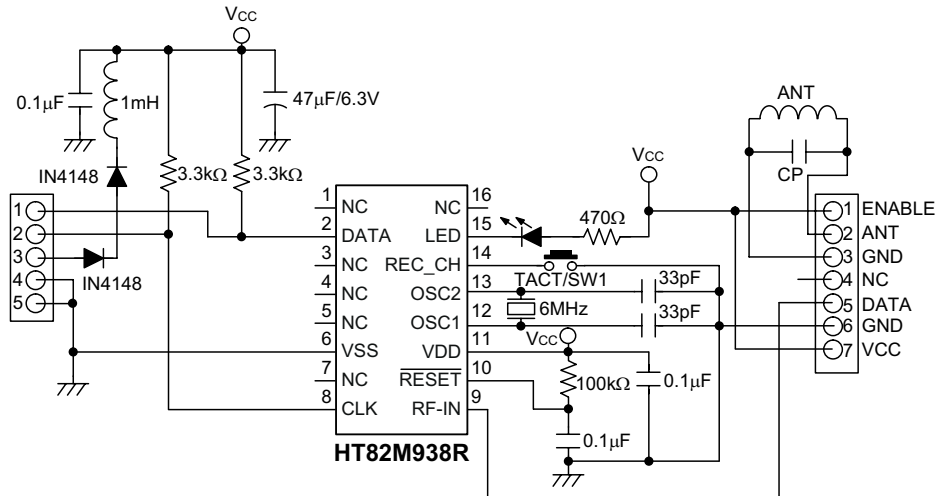

RF transmitter modules

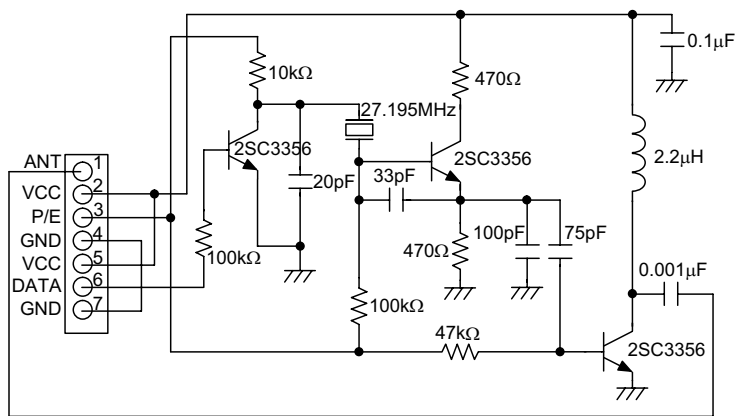

RF receiver modules

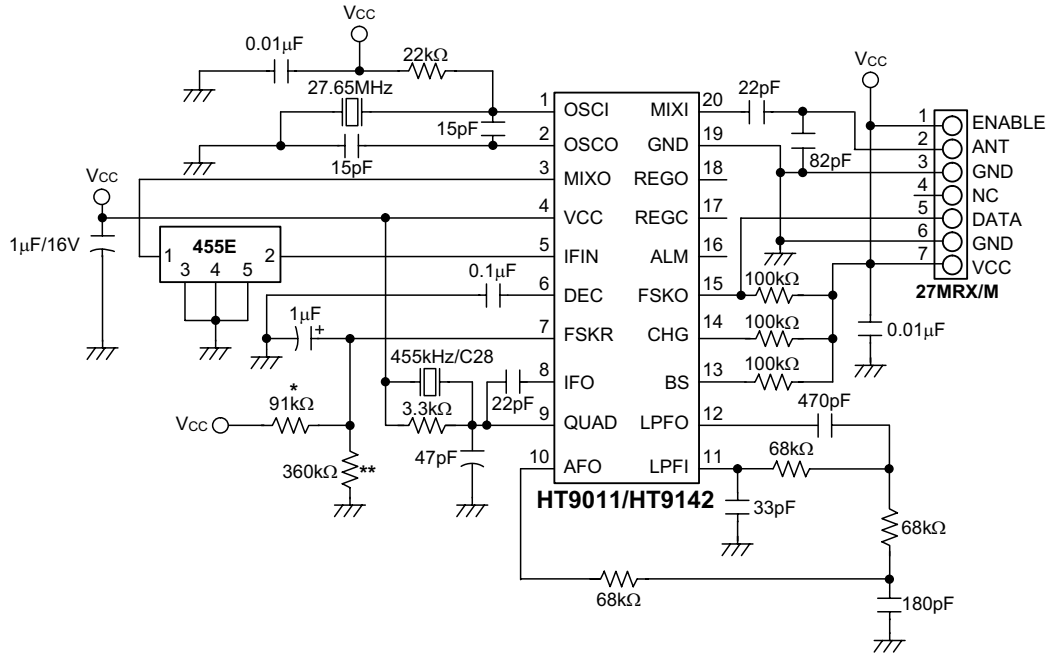

Note: For HT9011: place *, **open
 For HT9142: place**, *open

Package Information

20-pin SOP (300mil) outline dimensions

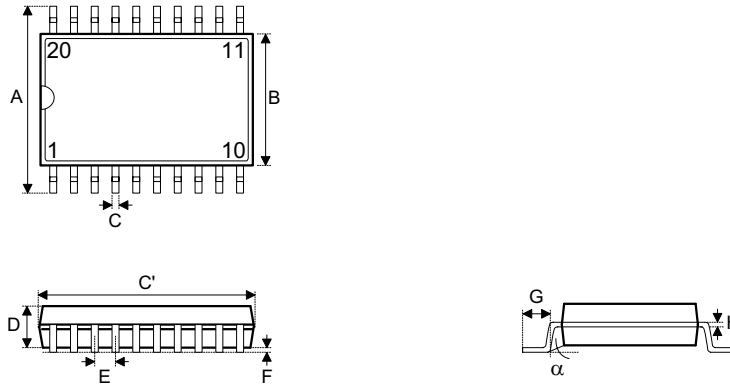

Symbol	Dimensions in mil		
	Min.	Nom.	Max.
A	394	—	419
B	290	—	300
C	14	—	20
C'	490	—	510
D	92	—	104
E	—	50	—
F	4	—	—
G	32	—	38
H	4	—	12
α	0°	—	10°

16-pin SOP (300mil) outline dimensions

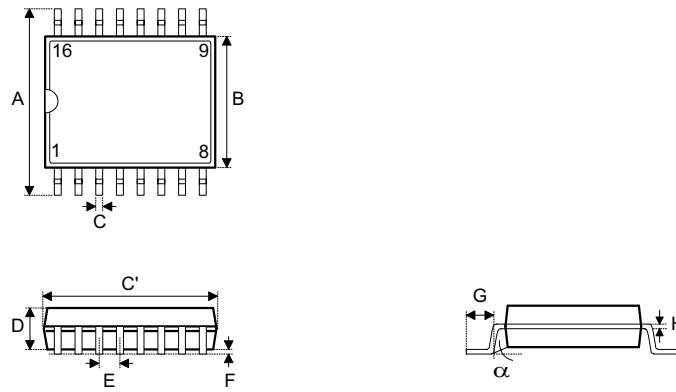

Symbol	Dimensions in mil		
	Min.	Nom.	Max.
A	394	—	419
B	290	—	300
C	14	—	20
C'	390	—	413
D	92	—	104
E	—	50	—
F	4	—	—
G	32	—	38
H	4	—	12
α	0°	—	10°

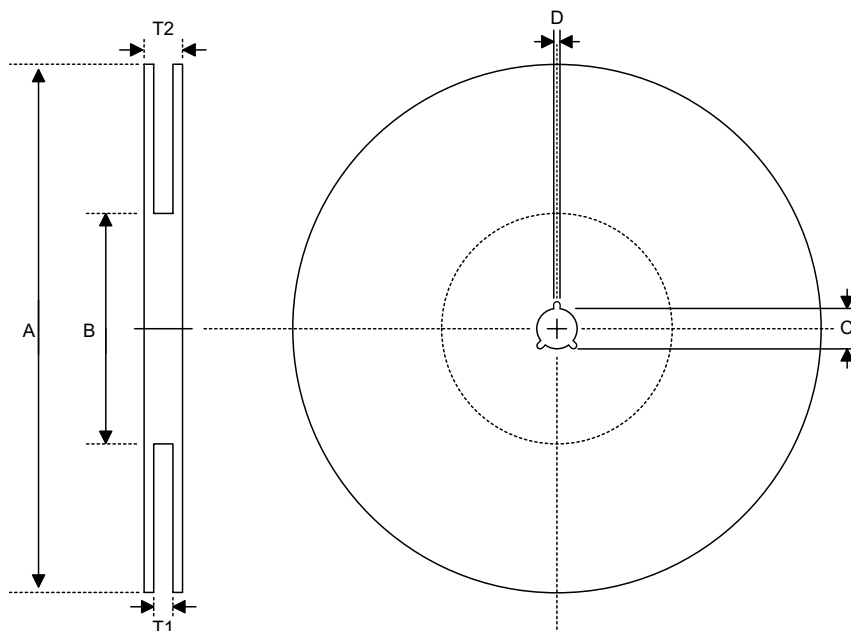
Product Tape and Reel Specifications
Reel dimensions

SOP 20W

Symbol	Description	Dimensions in mm
A	Reel Outer Diameter	330±1.0
B	Reel Inner Diameter	62±1.5
C	Spindle Hole Diameter	13.0+0.5 -0.2
D	Key Slit Width	2.0±0.5
T1	Space Between Flange	24.8+0.3 -0.2
T2	Reel Thickness	30.2±0.2

SOP 16W (300mil)

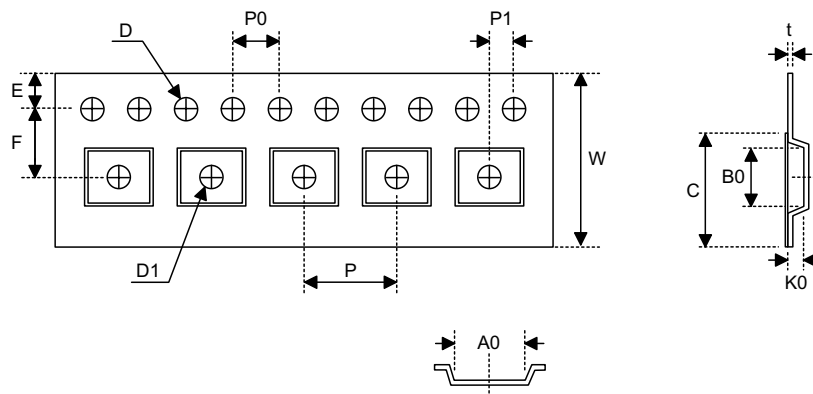
Symbol	Description	Dimensions in mm
A	Reel Outer Diameter	330±1.0
B	Reel Inner Diameter	62±1.5
C	Spindle Hole Diameter	13.0±0.5 -0.2
D	Key Slit Width	2.0±0.5
T1	Space Between Flange	16.8+0.3 -0.2
T2	Reel Thickness	22.2±0.2

Carrier tape dimensions

SOP 20W

Symbol	Description	Dimensions in mm
W	Carrier Tape Width	24.0+0.3 -0.1
P	Cavity Pitch	12.0±0.1
E	Perforation Position	1.75±0.1
F	Cavity to Perforation (Width Direction)	11.5±0.1
D	Perforation Diameter	1.5+0.1
D1	Cavity Hole Diameter	1.5+0.25
P0	Perforation Pitch	4.0±0.1
P1	Cavity to Perforation (Length Direction)	2.0±0.1
A0	Cavity Length	10.8±0.1
B0	Cavity Width	13.3±0.1
K0	Cavity Depth	3.2±0.1
t	Carrier Tape Thickness	0.3±0.05
C	Cover Tape Width	21.3

SOP 16W (300mil)

Symbol	Description	Dimensions in mm
W	Carrier Tape Width	16.0±0.2
P	Cavity Pitch	12.0±0.1
E	Perforation Position	1.75±0.1
F	Cavity to Perforation (Width Direction)	7.5±0.1
D	Perforation Diameter	1.5+0.1
D1	Cavity Hole Diameter	1.5+0.25
P0	Perforation Pitch	4.0±0.1
P1	Cavity to Perforation (Length Direction)	2.0±0.1
A0	Cavity Length	10.9±0.1
B0	Cavity Width	10.8±0.1
K0	Cavity Depth	3.0±0.1
t	Carrier Tape Thickness	0.3±0.05
C	Cover Tape Width	13.3

Holtek Semiconductor Inc. (Headquarters)

No.3, Creation Rd. II, Science Park, Hsinchu, Taiwan
Tel: 886-3-563-1999
Fax: 886-3-563-1189
<http://www.holtek.com.tw>

Holtek Semiconductor Inc. (Taipei Sales Office)

4F-2, No. 3-2, YuanQu St., Nankang Software Park, Taipei 115, Taiwan
Tel: 886-2-2655-7070
Fax: 886-2-2655-7373
Fax: 886-2-2655-7383 (International sales hotline)

Holtek Semiconductor Inc. (Shanghai Sales Office)

7th Floor, Building 2, No.889, Yi Shan Rd., Shanghai, China 200233
Tel: 021-6485-5560
Fax: 021-6485-0313
<http://www.holtek.com.cn>

Holtek Semiconductor Inc. (Shenzhen Sales Office)

43F, SEG Plaza, Shen Nan Zhong Road, Shenzhen, China 518031
Tel: 0755-8346-5589
Fax: 0755-8346-5590
ISDN: 0755-8346-5591

Holtek Semiconductor Inc. (Beijing Sales Office)

Suite 1721, Jinyu Tower, A129 West Xuan Wu Men Street, Xicheng District, Beijing, China 100031
Tel: 010-6641-0030, 6641-7751, 6641-7752
Fax: 010-6641-0125

Holmate Semiconductor, Inc. (North America Sales Office)

46712 Fremont Blvd., Fremont, CA 94538
Tel: 510-252-9880
Fax: 510-252-9885
<http://www.holmate.com>

Copyright © 2002 by HOLTEK SEMICONDUCTOR INC.

The information appearing in this Data Sheet is believed to be accurate at the time of publication. However, Holtek assumes no responsibility arising from the use of the specifications described. The applications mentioned herein are used solely for the purpose of illustration and Holtek makes no warranty or representation that such applications will be suitable without further modification, nor recommends the use of its products for application that may present a risk to human life due to malfunction or otherwise. Holtek's products are not authorized for use as critical components in life support devices or systems. Holtek reserves the right to alter its products without prior notification. For the most up-to-date information, please visit our web site at <http://www.holtek.com.tw>.