



TMC457

Stepper and Piezo Motor Controller (S-shape Ramps) with Encoder Interface, easyPID™ Feedback Control and Integrated Sequencer

INFO The TMC457 is a high-end single axis micro stepping motion controller for 2-phase bipolar stepper motors, piezo motors (Piezo LEGS®). Via step / direction interface 3-phase stepper motors can also be controlled (requires additional TMC332). It adds to any microcontroller or processor with SPI interface. It is intended for applications, where a precise and fast, jerk-free motion profile is desired. The TMC457 supports linear and S-shaped velocity ramps. It's chopSync™ feature allows high speed movement avoiding resonances.

An encoder can be added for extremely quick and precise positioning using the internal hardware PID regulator easyPID™ and for increased reliability / fault detection.

For maximum flexibility all motion control parameters (target position, target velocity, acceleration, deceleration and bow) can be changed on-the-fly at any time during motion.

MAIN CHARACTERISTICS

- S-shaped and linear ramps with on-the-fly alteration of all parameters
- programmable high resolution sequencer with (12bit, 8192 entry) micro step LUT table
- integrated sequencer
- incr. encoder interface with flexible up- and down scaling to match drive resolution
- fast and stable easyPID™ PID controller
- 32 bit registers "from mHz to MHz"
- reference switch processing
- virtual stop sw. (programmable soft limits)
- position pulse output to trigger ext. events
- synchronization of multiple axis via step/direction input
- integrated chopSync™ for high velocities
- analog high resolution motor driver control via external dual -low cost- 12 bit DAC
- energy saving by automatic load angle dependent current control

ELECTRICAL DATA INTERFACE

- 3.3V IO/ 1.5V core
- SPI interface to microcontroller
- step / direction output (with progr. timing)
- stallGuard™ interface for TMC246/TMC249 family stepper motor drivers
- FBGA144 package 13 x 13 mm²
- RoHS compliant

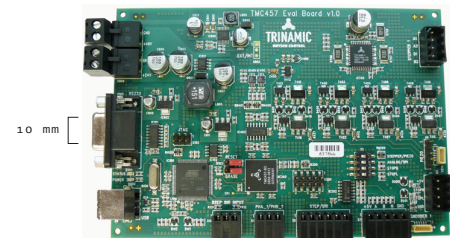
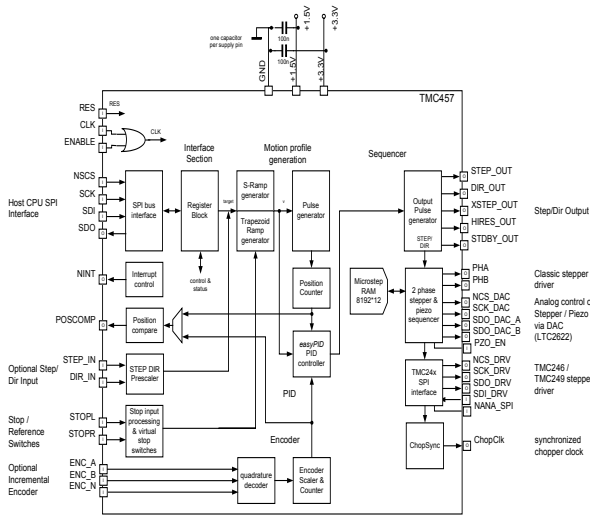

ORDER CODE	DESCRIPTION
TMC457-BC	1-axis motion controller with encoder feedback, FBGA144 package
Related product:	
TMC457-Eval	Evaluation board for TMC457