

XC6371

Series



PWM Controlled Step - Up DC/DC Controllers/Converters

- ◆ **CMOS Low Power Consumption**
- ◆ **Operating Voltage** : 0.9V~10.0V
- ◆ **Output Voltage Range** : 2.0V~7.0V
- ◆ **Output Voltage Accuracy** : ±2.5%
- ◆ **Selectable Oscillator Frequency**
: 50kHz, 100kHz,
180kHz

Applications

- Cellular phones, Pagers
- Palmtops
- Cameras, Video recorders
- Portable products

4

General Description

The XC6371 series are a group of PWM controlled step-up DC/DC converters.

On-chip proprietary phase compensation and soft start-up circuits ensure excellent transient response and improved performance.

Output voltage can be selected from 2.0V to 7.0V in 0.1V increments (accuracy: ±2.5%). Oscillator frequency is also selectable from three frequencies; 50, 100, and 180kHz (accuracy: ±15%).

Every built-in switching transistor type enables a step-up circuit to be configured using only three external components; a coil, a diode, and a capacitor.

External transistor versions are available to accommodate high output current applications.

5-pin packages, which are provided with either a CE (chip enable) function that reduces power consumption during shut-down mode, or a V_{DD} pin (separated power and voltage detect pins) are available.

SOT-89 small package.

Features

Operating (start-up) voltage range

: 0.9V~10V

Output voltage range : 2.0V~7.0V in 0.1V increments

Highly accurate : Set-up voltage ±2.5%

Oscillator frequency : 50kHz, 100kHz, 180kHz (±15%)
selectable

Maximum output currents (Tr built-in)

: Typ.100mA @ V_{IN}=3.0,

V_{OUT}=5.0VNote(1)

Highly efficient (Tr built-in)

: Typ.85% @ V_{IN}=3.0,

V_{OUT}=5.0VNote(1)

Built-in switching transistor type and an external Tr type are available.

Five-lead packaged units offer either Chip Enable or independent V_{OUT} pin option.

Phase compensation and soft start-up circuits built-in Small package : SOT-89 mini-power mold (3-pin, 5-pin)

Note(1): Performance depends on external components and PCB layout.

Typical Application Circuit

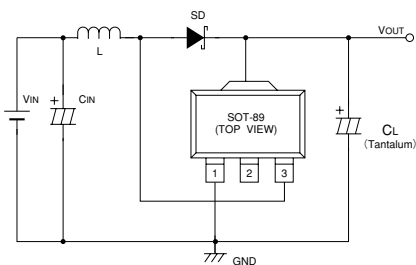

Typical Performance Characteristic

XC6371A301PR

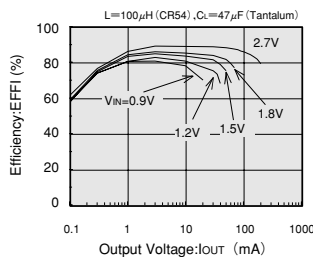

XC6371 Series

Pin Configuration

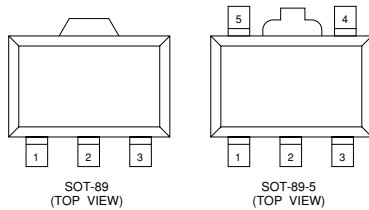

Pin Assignment

(XC6371A, XC6371B)

PIN NUMBER		PIN NAME	FUNCTION
XC6371A	XC6371B		
1	1	V _{SS}	Ground
2	2	V _{OUT}	Output voltage monitor / IC internal power supply
3	-	L _x	Switch
-	3	EXT	External switch transistor drive

(XC6371C, XC6371D)

PIN NUMBER		PIN NAME	FUNCTION
XC6371C	XC6371D		
5	5	V _{SS}	Ground
2	2	V _{OUT}	Output voltage monitor / IC internal power supply
4	-	L _x	Switch
-	4	EXT	External switch transistor drive
3	3	CE	Chip Enable
1	1	NC	No Connection

(XC6371E, XC6371F)

PIN NUMBER		PIN NAME	FUNCTION
XC6371E	XC6371F		
5	5	V _{SS}	Ground
2	2	V _{DD}	IC internal power supply
4	-	L _x	Switch
-	4	EXT	External switch transistor drive
3	3	V _{OUT}	Output voltage monitor
1	1	NC	No Connection

4

Product Classification

Selection Guide

PART TYPE	OPERATION MODE	PACKAGE	SWITCHING RELATED	ADDITIONAL FUNCTION	FEATURES
XC6371A	PWM	SOT-89	Built-in Transistor "Lx"lead	-----	<ul style="list-style-type: none"> Switching transistor incorporated standard type. Low ripple and highly efficient from low current to high current.
XC6371B	PWM	SOT-89	External Transistor "EXT"lead	-----	<ul style="list-style-type: none"> External switching transistor standard type. Adding external transistor can improve the output capability up to several hundred mA.
XC6371C	PWM	SOT-89-5	Built-in Transistor "Lx"lead	Chip Enable(CE)	<ul style="list-style-type: none"> Stand-by (CE)function added version to the XC6371A. Stand-by current: 0.5μA max.
XC6371D	PWM	SOT-89-5	External Transistor "EXT"lead	Chip Enable(CE)	<ul style="list-style-type: none"> Stand-by (CE)function added version to the XC6371B. Stand-by current: 0.5μA max.
XC6371E	PWM	SOT-89-5	Built-in Transistor "Lx"lead	Separated "V _{DD} "and"V _{OUT} "leads	<ul style="list-style-type: none"> Individual power supply and set-up voltage sensing leads are available.
XC6371F	PWM	SOT-89-5	External Transistor "EXT"lead	Separated "V _{DD} "and"V _{OUT} "leads	<ul style="list-style-type: none"> Individual power supply and set-up voltage sensing leads are available.

4

Ordering Information

XC6371①②③④⑤⑥

XC6371 Series		PWM Controlled
①	A	3-pin, Built-in switching transistor
	B	3-pin, External switching transistor
	C	Stand-by capability, Built-in switching transistor
	D	Stand-by capability, External switching transistor
	E	Separated V _{DD} and V _{OUT} , Built-in switching transistor
	F	Separated V _{DD} and V _{OUT} , External switching transistor
② ③		Output Voltage e.g., V _{OUT} =3.5V → ②=3, ③=5
④	0	OSC Frequency 50kHz
	1	OSC Frequency 100kHz
	2	OSC Frequency 180kHz
⑤	P	Package ①=A ~ B → SOT-89 ①=C ~ F → SOT-89-5
	R	Embossed tape: Standard Feed
⑥	L	Embossed tape: Reverse Feed

XC6371 Series

■ Packaging Information

● SOT-89

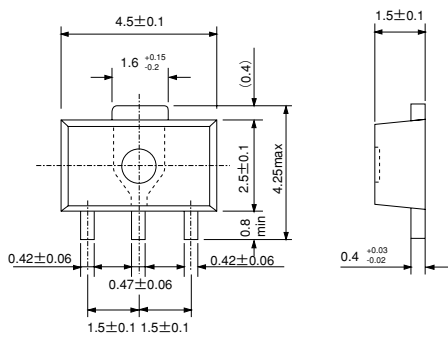

4

● SOT-89-5

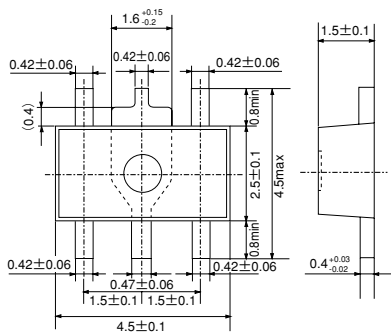

Marking

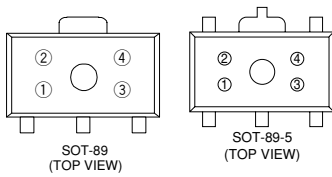

① Represents the Product Classification

PRODUCT NAME	DESIGNATOR
XC6371A	A
XC6371B	B
XC6371C	A
XC6371D	B
XC6371E	S
XC6371F	X

4

② Represents the integer of the Output Voltage and Oscillator Frequency

INTEGER OF THE OUTPUT VOLTAGE	OSCILLATOR FREQUENCY (kHz)		
	50	100	180
1	B	1	1
2	C	2	2
3	D	3	3
4	E	4	4
5	F	5	5
6	H	6	6
7	K	7	7

③ Represents the decimal number of the Output Voltage and Oscillator Frequency

THE DECIMAL NUMBER OF OUTPUT VOLTAGE	OSCILLATOR FREQUENCY (kHz)		
	50	100	180
0	0	0	A
1	1	1	B
2	2	2	C
3	3	3	D
4	4	4	E
5	5	5	F
6	6	6	H
7	7	7	K
8	8	8	L
9	9	9	M

④ Denotes the production lot number
0 to 9, A to Z repeated(G,I,J,O,Q,W excepted)

XC6371 Series

Block Diagram

XC6371A~XC6371D

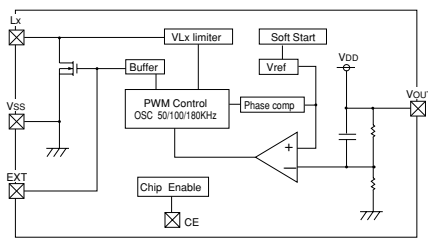

Note: Built-in tr.type units use the LX pin. External tr.type units use the EXT pin.
The CE pin is only used with the XC6371C and XC6371D.
The VOUT pin is used also for the VDD pin.

XC6371E and XC6371F

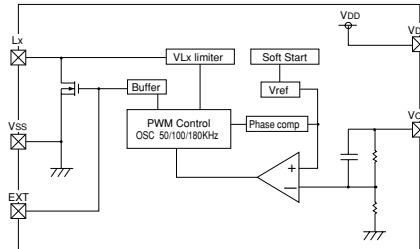

Note: The VDD pin is only used with XC6371E and XC6371F.
Built-in tr.type units use the LX pin. External tr.type units use the EXT pin.

4

Absolute Maximum Ratings

Ta=25°C

PARAMETER	SYMBOL	RATINGS	UNITS
V _{OUT} Input Voltage	V _{OUT}	12	V
Lx pin Voltage	V _{LX}	12	V
Lx pin Current	I _{LX}	400	mA
EXT pin Voltage	V _{EXT}	V _{SS} -0.3 ~ V _{OUT} +0.3	V
EXT pin Current	I _{EXT}	±50	mA
CE Input Voltage	V _{CE}	12	V
Continuous Total Power Dissipation	P _d	500	mW
VDD Input Voltage	V _{DD}	12	V
Operating Ambient Temperature	T _{opr}	-30 ~ +80	°C
Storage Temperature	T _{stg}	-40 ~ +125	°C

Electrical Characteristics

XC6371A501PR

V_{OUT}=5.0V, F_{OSC}=100kHz

Ta=25°C

PARAMETER	SYMBOL	CONDITIONS	MIN	TYP	MAX	UNITS
Output Voltage	V _{OUT}		4.875	5.000	5.125	V
Maximum Input Voltage	V _{IN}		10			V
Operation Start-up Voltage	V _{ST1}	External Components Connected. I _{OUT} =1mA.			0.90	V
Oscillation Start-up Voltage	V _{ST2}	No external components. Apply voltage to V _{OUT} . Lx : 10kΩ pull-up to 5V.			0.80	V
Supply Current 1	I _{DD1}	Same as V _{ST2} . Apply output voltage X0.95 to V _{OUT} .		80.2	133.8	μA
Supply Current 2	I _{DD2}	Same as V _{ST2} . Apply output voltage X1.1 to V _{OUT} .		8.2	16.5	μA
Lx Switch-On Resistance	R _{SWON}	Same as I _{DD1} . V _{LX} =0.4V.		1.4	2.4	Ω
Lx Leakage Current	I _{LXL}	No external components. V _{OUT} =V _{LX} =10V.			1.0	μA
Oscillator Frequency	F _{OSC}	Same as I _{DD1} . Measuring of Lx waveform.	85	100	115	kHz
Maximum Duty Ratio	MAXDTY	Same as I _{DD1} . Measuring of Lx waveform.	80	87	92	%
Lx Limit Voltage	V _{LXLMT}	Same as I _{DD1} . Apply output voltage to Lx. Voltage required to produce F _{OSC} X ₂ .	0.7		1.3	V
Efficiency	EFFI			85		%
Slow-Start Time	T _{SS}		4.0	10.0	20.0	ms

Measuring conditions : Unless otherwise specified, V_{IN}=V_{OUT} X 0.6, I_{OUT}=50mA. See Typical Application Circuits, Fig.1.

XC6371
Series

XC6371B501PR $V_{OUT}=5.0V, F_{OSC}=100kHz$ $T_a=25^{\circ}C$

PARAMETER	SYMBOL	CONDITIONS	MIN	TYP	MAX	UNITS
Output Voltage	V_{OUT}		4.875	5.000	5.125	V
Maximum Input Voltage	V_{IN}		10			V
Operation Start-up Voltage	V_{ST1}	External Components Connected. $I_{OUT}=1mA$.			0.90	V
Oscillation Start-up Voltage	V_{ST2}	No external components. Apply voltage to V_{OUT} .			0.80	V
Supply Current 1	I_{DD1}	Same as V_{ST2} . Apply output voltage $\times 0.95$ to V_{OUT} .		40.0	66.8	μA
Supply Current 2	I_{DD2}	Same as V_{ST2} . Apply output voltage $\times 1.1$ to V_{OUT} .		8.2	16.5	μA
EXT"High" On Resistance	R_{EXTH}	Same as I_{DD1} . $V_{EXT}=-0.4V$.		37.5	62.5	Ω
EXT"Low" On Resistance	R_{EXTL}	Same as I_{DD1} . $V_{EXT}=0.4V$.		30	50	Ω
Oscillator Frequency	F_{OSC}	Same as I_{DD1} . Measuring of EXT waveform.	85	100	115	kHz
Maximum Duty Ratio	$MAXDTY$	Same as I_{DD1} . Measuring of EXT waveform.	80	87	92	%
Efficiency	$EFFI$			85		%
Slow-Start Time	T_{SS}		4.0	10.0	20.0	ms

Measuring conditions: Unless otherwise specified, $V_{IN}=V_{OUT}\times 0.6$, $I_{OUT}=50mA$. See Typical Application Circuits, Fig.2.

4

XC6371C501PR $V_{OUT}=5.0V, F_{OSC}=100kHz$ $T_a=25^{\circ}C$

PARAMETER	SYMBOL	CONDITIONS	MIN	TYP	MAX	UNITS
Output Voltage	V_{OUT}		4.875	5.000	5.125	V
Maximum Input Voltage	V_{IN}		10			V
Operation Start-up Voltage	V_{ST1}	External Components Connected. $I_{OUT}=1mA$.			0.90	V
Oscillation Start-up Voltage	V_{ST2}	No external components. Apply voltage to V_{OUT} . $L_x: 10k\Omega$ pull-up to 5V.			0.80	V
Supply Current 1	I_{DD1}	Same as V_{ST2} . Apply output voltage $\times 0.95$ to V_{OUT} .		80.2	133.8	μA
Supply Current 2	I_{DD2}	Same as V_{ST2} . Apply output voltage $\times 1.1$ to V_{OUT} .		8.2	16.5	μA
Lx Switch-On Resistance	R_{SWON}	Same as I_{DD1} . $V_{LX}=0.4V$.		1.4	2.4	Ω
Lx Leakage Current	I_{LXL}	No external components. $V_{OUT}=V_{LX}=10V$.			1.0	μA
Oscillator Frequency	F_{OSC}	Same as I_{DD1} . Measuring of Lx waveform.	85	100	115	kHz
Maximum Duty Ratio	$MAXDTY$	Same as I_{DD1} . Measuring of Lx waveform.	80	87	92	%
Stand-by Current	I_{STB}	Same as I_{DD1} .			0.5	μA
CE"High" Voltage	V_{CEH}	Same as I_{DD1} . Existence of Lx Oscillation.	0.75			V
CE"Low" Voltage	V_{CEL}	Same as I_{DD1} . Disappearance of Lx Oscillation.			0.20	V
CE"High" Current	I_{CEH}	Same as I_{DD1} . $V_{CE}=V_{OUT}\times 0.95$.			0.25	μA
CE"Low" Current	I_{CEL}	Same as I_{DD1} . $V_{CE}=0V$.			-0.25	μA
Lx Limit Voltage	V_{LXLMT}	Same as I_{DD1} . Apply output voltage to Lx. Voltage required to produce $F_{OSC}\times 2$.	0.7		1.3	V
Efficiency	$EFFI$			85		%
Slow-Start Time	T_{SS}		4.0	10.0	20.0	ms

Measuring conditions: Unless otherwise specified, connect CE to V_{OUT} , $V_{IN}=V_{OUT}\times 0.6$, $I_{OUT}=50mA$. See Typical Application Circuits, Fig.3.

XC6371 Series

XC6371D501PR $V_{OUT}=5.0V, F_{OSC}=100kHz$ $T_a=25^{\circ}C$

PARAMETER	SYMBOL	CONDITIONS	MIN	TYP	MAX	UNITS
Output Voltage	V_{OUT}		4.875	5.000	5.125	V
Maximum Input Voltage	V_{IN}		10			V
Operation Start-up Voltage	V_{ST1}	External Components Connected. $I_{OUT}=1mA$.			0.90	V
Oscillation Start-up Voltage	V_{ST2}	No external components. Apply voltage to V_{OUT} .			0.80	V
Supply Current 1	I_{DD1}	Same as V_{ST2} . Apply output voltage $\times 0.95$ to V_{OUT} .		40.0	66.8	μA
Supply Current 2	I_{DD2}	Same as V_{ST2} . Apply output voltage $\times 1.1$ to V_{OUT} .		8.2	16.5	μA
EXT "High" On Resistance	R_{EXTH}	Same as I_{DD1} . $V_{EXT}=-0.4V$.		37.5	62.5	Ω
EXT "Low" On Resistance	R_{EXTL}	Same as I_{DD1} . $V_{EXT}=0.4V$.		30	50	Ω
Oscillator Frequency	F_{OSC}	Same as I_{DD1} . Measuring of EXT waveform.	85	100	115	kHz
Maximum Duty Ratio	$MAXDTY$	Same as I_{DD1} . Measuring of EXT waveform.	80	87	92	%
Stand-by Current	I_{STB}	Same as I_{DD1} .			0.5	μA
CE"High" Voltage	V_{CEH}	Same as I_{DD1} . Existence of Lx Oscillation.	0.75			V
CE"Low" Voltage	V_{CEL}	Same as I_{DD1} . Disappearance of Lx Oscillation.			0.20	V
CE"High" Current	I_{CEH}	Same as I_{DD1} . $V_{CE}=V_{OUT} \times 0.95$.			0.25	μA
CE"Low" Current	I_{CEL}	Same as I_{DD1} . $V_{CE}=0V$.			-0.25	μA
Efficiency	$EFFI$			85		%
Slow-Start Time	T_{SS}		4.0	10.0	20.0	ms

Measuring conditions: Unless otherwise specified, connect CE to V_{OUT} . $V_{IN}=V_{OUT} \times 0.6$, $I_{OUT}=50mA$. See Typical Application Circuits, Fig.4.

XC6371E501PR $V_{OUT}=5.0V, F_{OSC}=100kHz$ $T_a=25^{\circ}C$

PARAMETER	SYMBOL	CONDITIONS	MIN	TYP	MAX	UNITS
Output Voltage	V_{OUT}		4.875	5.000	5.125	V
Maximum Input Voltage	V_{IN}		10			V
Operation Start-up Voltage	V_{ST1}	External Components Connected. $I_{OUT}=1mA$.			0.90	V
Oscillation Start-up Voltage	V_{ST2}	No external components. Apply voltage to V_{OUT} .			0.80	V
Supply Current 1	I_{DD1}	Same as V_{ST2} . Apply output voltage $\times 0.95$ to V_{OUT} .		80.2	133.8	μA
Supply Current 2	I_{DD2}	Same as V_{ST2} . Apply output voltage $\times 1.1$ to V_{OUT} .		8.2	16.5	μA
Lx Switch-On Resistance	R_{SWON}	Same as I_{DD1} . $V_{LX}=0.4V$.		1.4	2.4	Ω
Lx Leakage Current	I_{LXL}	No external components. $V_{OUT}=V_{LX}=10V$.			1.0	μA
Oscillator Frequency	F_{OSC}	Same as I_{DD1} . Measuring of Lx waveform.	85	100	115	kHz
Maximum Duty Ratio	$MAXDTY$	Same as I_{DD1} . Measuring of Lx waveform.	80	87	92	%
Lx Limit Voltage	V_{LXLMT}	Same as I_{DD1} . Apply output voltage to Lx. Voltage required to produce $F_{OSC} \times 2$.	0.7		1.3	V
Efficiency	$EFFI$			85		%
Slow-Start Time	T_{SS}		4.0	10.0	20.0	ms

Measuring conditions: Unless otherwise specified, connect V_{DD} to V_{OUT} . $V_{IN}=V_{OUT} \times 0.6$, $I_{OUT}=50mA$. See Typical Application Circuits, Fig.5.
Note: When the V_{DD} and V_{OUT} pins are independently used, the voltage range at the V_{DD} pin should be 2.2V to 10V.

The IC operates from $V_{DD}=0.8V$. However, output voltage and oscillator frequency are properly stabilized when $V_{DD}=2.2V$ or higher.

XC6371 Series

XC6371F501PR $V_{OUT}=5.0V, F_{OSC}=100kHz$ $T_a=25^{\circ}C$

PARAMETER	SYMBOL	CONDITIONS	MIN	TYP	MAX	UNITS
Output Voltage	V_{OUT}		4.875	5.000	5.125	V
Maximum Input Voltage	V_{IN}		10			V
Operation Start-up Voltage	V_{st1}	External Components Connected. $I_{OUT}=1mA$.			0.90	V
Oscillation Start-up Voltage	V_{st2}	No external components. Apply voltage to V_{OUT} .			0.80	V
Supply Current 1	I_{DD1}	Same as V_{st2} . Apply output voltage $\times 0.95$ to V_{OUT} .		40.0	66.8	μA
Supply Current 2	I_{DD2}	Same as V_{st2} . Apply output voltage $\times 1.1$ to V_{OUT} .		8.2	16.5	μA
EXT "High" On-Resistance	R_{EXTH}	Same as I_{DD1} . $V_{EXT}=-0.4V$.		37.5	62.5	Ω
EXT "Low" On-Resistance	R_{EXTL}	Same as I_{DD1} . $V_{EXT}=0.4V$.		30	50	Ω
Oscillator Frequency	F_{OSC}	Same as I_{DD1} . Measuring of EXT waveform.	85	100	115	kHz
Maximum Duty Ratio	MAXDTY	Same as I_{DD1} . Measuring of EXT waveform.	85	87	92	%
Efficiency	EFFI			85		%
Slow-Start Time	T_{SS}		4.0	10.0	20.0	ms

Measuring conditions: Unless otherwise specified, connect V_{DD} to V_{OUT} , $V_{IN}=V_{OUT}\times 0.6$, $I_{OUT}=50mA$. See Typical Application Circuits, Fig.6.

Note: When the V_{DD} and V_{OUT} pins are independently used, the voltage range at the V_{DD} pin should be 2.2V to 10V.

The IC operates from $V_{DD}=0.8V$. However, output voltage and oscillator frequency are properly stabilized when $V_{DD}=2.2V$ or higher.

4

Typical Application Circuits

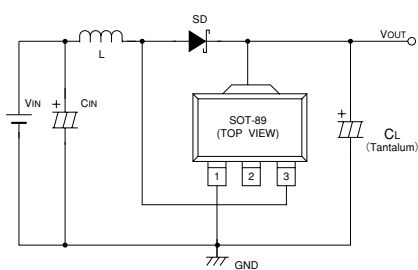

L : 100 μ H (SUMIDA, CR-54)
SD : MA2Q735 (Schottky diode; MATSUSHITA)
CL : 16V 47 μ F (Tantalum capacitor; NICHCON, MCE)
CIN : 16V220 μ F (Aluminium Electrolytic Capacitor)

Fig.1 XC6371A Application

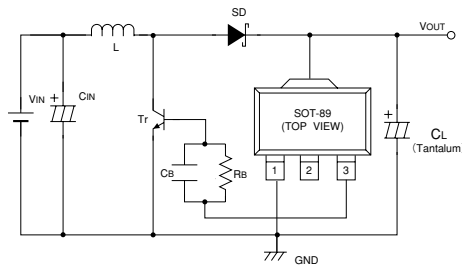

L : 47 μ H (SUMIDA, CR-54)
SD : MA2Q735 (Schottky diode; MATSUSHITA)
CL : 16V 47 μ F (Tantalum capacitor; NICHCON MCE)
CIN : 16V220 μ F (Aluminium Electrolytic Capacitor)
RB : 1k Ω , CB:3300pF ($F_{OSC}=100kHz$)
Tr : 2SC3279, 2SD1628G

Fig.2 XC6371B Application

XC6371 Series

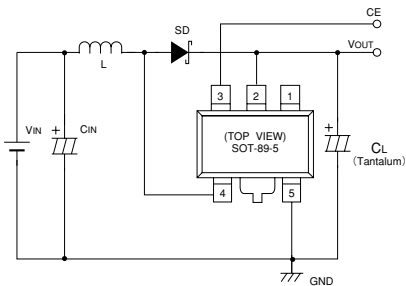

L : 100 μ H (SUMIDA, CR-54)
 SD : MA2Q735 (Schottky diode; MATSUSHITA)
 CL : 16V 47 μ F (Tantalum capacitor, NICHICON, MCE)
 CIN : 16V220 μ F (Aluminium Electrolytic Capacitor)

Fig.3 XC6371C Application

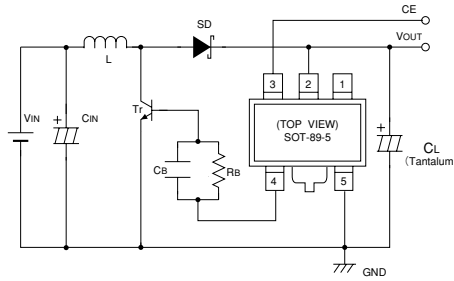

L : 47 μ H (SUMIDA, CR-54)
 SD : MA2Q735 (Schottky diode; MATSUSHITA)
 CL : 16V 47 μ F (Tantalum capacitor, NICHICON, MCE)
 CIN : 16V220 μ F (Aluminium Electrolytic Capacitor)
 RB : 1k Ω , CB : 3300pF (Fosc=100kHz)
 Tr : 2SC3279, 2SD1628G

Fig.4 XC6371D Application

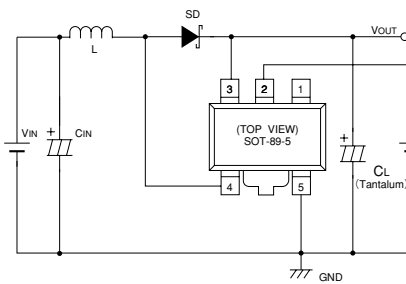

L : 100 μ H (SUMIDA, CR-54)
 SD : MA2Q735 (Schottky diode; MATSUSHITA)
 CL : 16V 47 μ F (Tantalum capacitor, NICHICON, MCE)
 CIN : 16V220 μ F (Aluminium Electrolytic Capacitor)

Fig.5 XC6371E Application

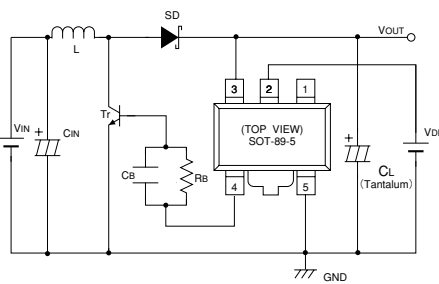

L : 47 μ H (SUMIDA, CR-54)
 SD : MA2Q735 (Schottky diode; MATSUSHITA)
 CL : 16V 47 μ F (Tantalum capacitor, NICHICON, MCE)
 CIN : 16V220 μ F (Aluminium Electrolytic Capacitor)
 RB : 1k Ω , CB : 3300pF (Fosc=100kHz)
 Tr : 2SC3279, 2SD1628G

Fig.6 XC6371F Application

Typical Performance Characteristics

(1) OUTPUT VOLTAGE vs. OUTPUT CURRENT

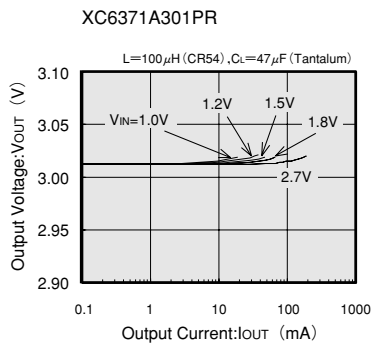
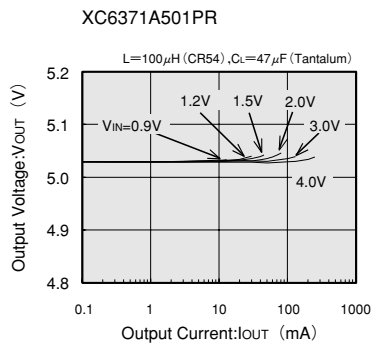

4

(2) EFFICIENCY vs. OUTPUT CURRENT

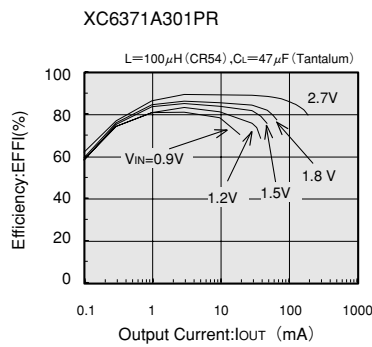
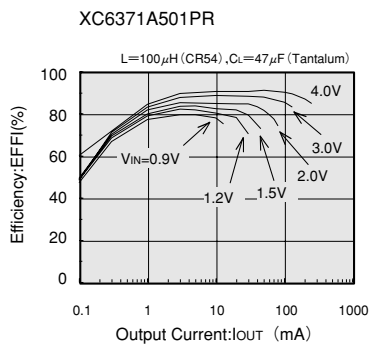

(3) RIPPLE VOLTAGE vs. OUTPUT CURRENT

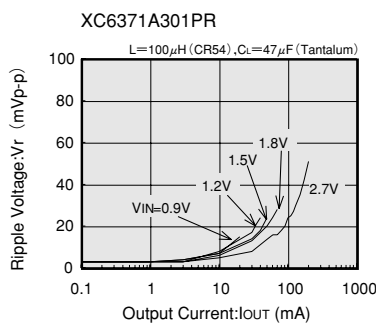
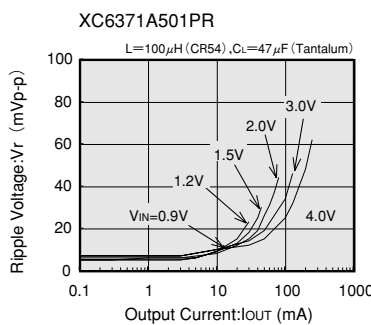

XC6371 Series

(4) NO LOAD, INPUT CURRENT vs. INPUT VOLTAGE

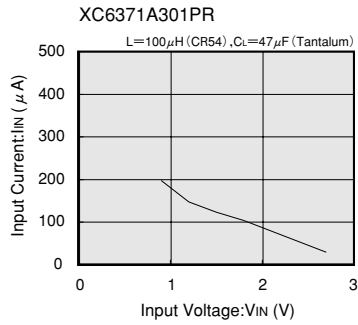
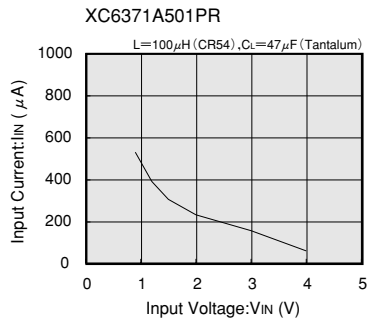

4

(5) OPERATING START VOLTAGE/RETAIN VOLTAGE vs. OUTPUT CURRENT

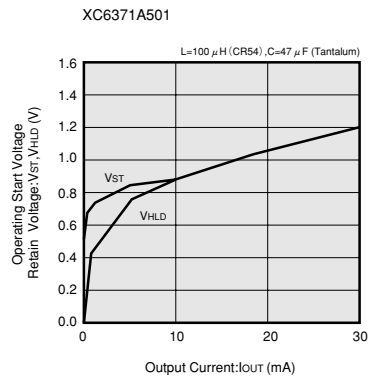

(6) LOAD TRANSIENT RESPONSE

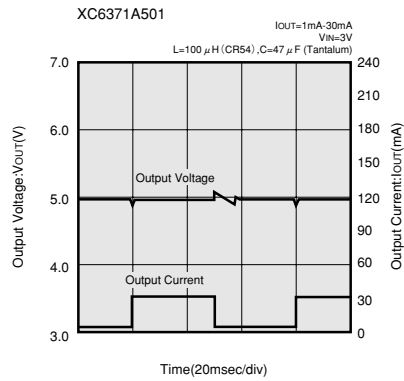

(7) OUTPUT VOLTAGE vs. OUTPUT CURRENT

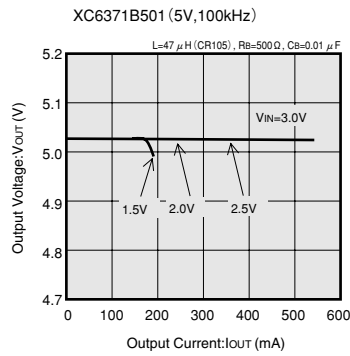
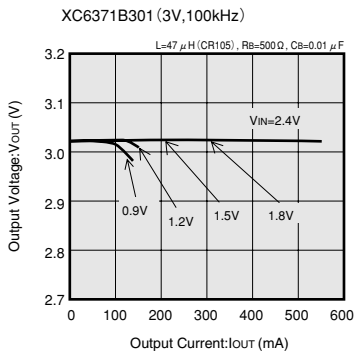

4

(8) EFFICIENCY vs. OUTPUT CURRENT

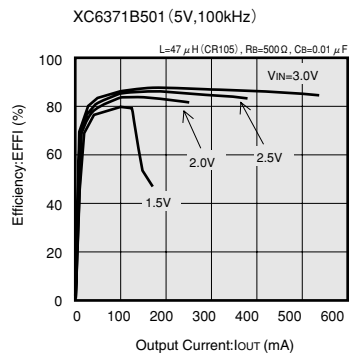
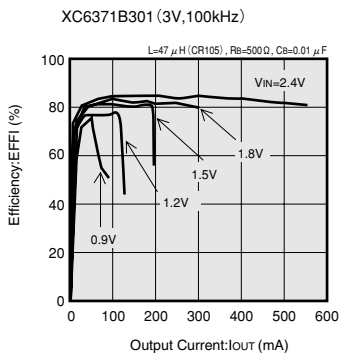

(9) RIPPLE VOLTAGE vs. OUTPUT CURRENT

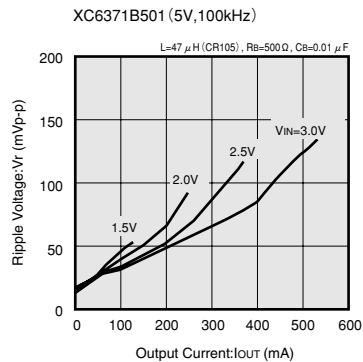
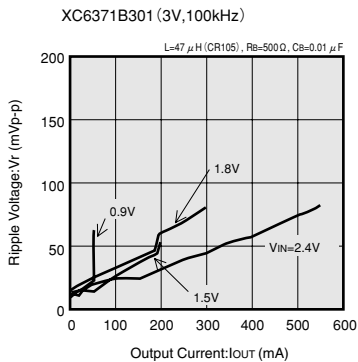

<External components>
 $C_N=100\ \mu\text{F (Electrolytic)}, C_L=47\ \mu\text{F (Tantalum)} \times 2, \text{SD:MA735, Tr:2SD1628G}$

XC6371 Series

(10) LOAD TRANSIENT RESPONSE

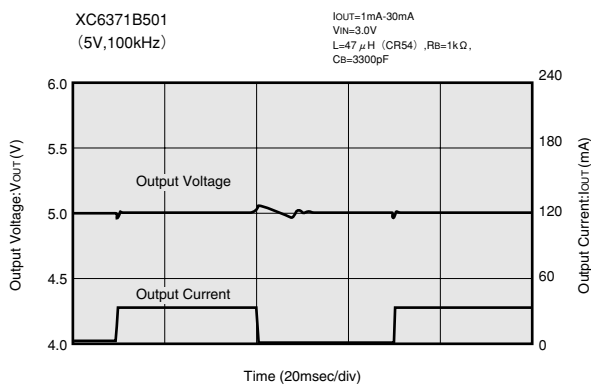
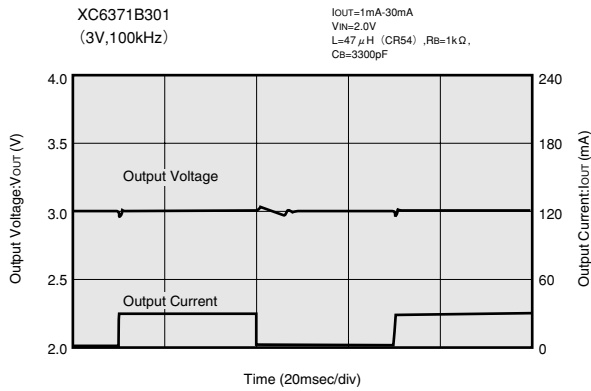

(External Components)
 $C_{IN}=47\mu F$ (Tantalum)
 $C_L=47\mu F$ (Tantalum) $\times 2$
SD:MA735
Tr :2SD1628G