

## Features

- High-performance, Low-power AVR<sup>®</sup> 8-bit Microcontroller
- Advanced RISC Architecture
  - 133 Powerful Instructions – Most Single Clock Cycle Execution
  - 32 x 8 General Purpose Working Registers + Peripheral Control Registers
  - Fully Static Operation
  - Up to 16 MIPS Throughput at 16 MHz
  - On-chip 2-cycle Multiplier
- Non volatile Program and Data Memories
  - 32K/64K/128K Bytes of In-System Reprogrammable Flash (AT90CAN32/64/128)
    - Endurance: 10,000 Write/Erase Cycles
  - Optional Boot Code Section with Independent Lock Bits
    - Selectable Boot Size: 1K Bytes, 2K Bytes, 4K Bytes or 8K Bytes
    - In-System Programming by On-Chip Boot Program (CAN, UART, ...)
    - True Read-While-Write Operation
  - 1K/2K/4K Bytes EEPROM (Endurance: 100,000 Write/Erase Cycles) (AT90CAN32/64/128)
  - 2K/4K/4K Bytes Internal SRAM (AT90CAN32/64/128)
  - Up to 64K Bytes Optional External Memory Space
  - Programming Lock for Software Security
- JTAG (IEEE std. 1149.1 Compliant) Interface
  - Boundary-scan Capabilities According to the JTAG Standard
  - Programming Flash (Hardware ISP), EEPROM, Lock & Fuse Bits
  - Extensive On-chip Debug Support
- CAN Controller 2.0A & 2.0B - ISO 16845 Certified <sup>(1)</sup>
  - 15 Full Message Objects with Separate Identifier Tags and Masks
  - Transmit, Receive, Automatic Reply and Frame Buffer Receive Modes
  - 1Mbits/s Maximum Transfer Rate at 8 MHz
  - Time stamping, TTC & Listening Mode (Spying or Autobaud)
- Peripheral Features
  - Programmable Watchdog Timer with On-chip Oscillator
  - 8-bit Synchronous Timer/Counter-0
    - 10-bit Prescaler
    - External Event Counter
    - Output Compare or 8-bit PWM Output
  - 8-bit Asynchronous Timer/Counter-2
    - 10-bit Prescaler
    - External Event Counter
    - Output Compare or 8-Bit PWM Output
    - 32Khz Oscillator for RTC Operation
  - Dual 16-bit Synchronous Timer/Counters-1 & 3
    - 10-bit Prescaler
    - Input Capture with Noise Canceler
    - External Event Counter
    - 3-Output Compare or 16-Bit PWM Output
    - Output Compare Modulation
  - 8-channel, 10-bit SAR ADC
    - 8 Single-ended Channels
    - 7 Differential Channels
    - 2 Differential Channels With Programmable Gain at 1x, 10x, or 200x
  - On-chip Analog Comparator
  - Byte-oriented Two-wire Serial Interface
  - Dual Programmable Serial USART
  - Master/Slave SPI Serial Interface
    - Programming Flash (Hardware ISP)
- Special Microcontroller Features
  - Power-on Reset and Programmable Brown-out Detection
  - Internal Calibrated RC Oscillator
  - 8 External Interrupt Sources
  - 5 Sleep Modes: Idle, ADC Noise Reduction, Power-save, Power-down & Standby
  - Software Selectable Clock Frequency
  - Global Pull-up Disable
- I/O and Packages
  - 53 Programmable I/O Lines
  - 64-lead TQFP and 64-lead QFN
- Operating Voltages: 2.7 - 5.5V
- Operating temperature: Industrial (-40°C to +85°C)
- Maximum Frequency: 8 MHz at 2.7V, 16 MHz at 4.5V

Note: 1. Details on [section 19.4.3 on page 242](#).



**8-bit AVR<sup>®</sup>  
Microcontroller  
with  
32K/64K/128K  
Bytes of  
ISP Flash  
and  
CAN Controller**

**AT90CAN32  
AT90CAN64  
AT90CAN128**

**Summary**

Rev. 7679HS-CAN-08/08



## 1. Description

### 1.1 Comparison Between AT90CAN32, AT90CAN64 and AT90CAN128

AT90CAN32, AT90CAN64 and AT90CAN128 are hardware and software compatible. They differ only in memory sizes as shown in [Table 1-1](#).

**Table 1-1.** Memory Size Summary

Device	Flash	EEPROM	RAM
AT90CAN32	32K Bytes	1K Byte	2K Bytes
AT90CAN64	64K Bytes	2K Bytes	4K Bytes
AT90CAN128	128K Bytes	4K Byte	4K Bytes

### 1.2 Part Description

The AT90CAN32/64/128 is a low-power CMOS 8-bit microcontroller based on the AVR enhanced RISC architecture. By executing powerful instructions in a single clock cycle, the AT90CAN32/64/128 achieves throughputs approaching 1 MIPS per MHz allowing the system designer to optimize power consumption versus processing speed.

The AVR core combines a rich instruction set with 32 general purpose working registers. All 32 registers are directly connected to the Arithmetic Logic Unit (ALU), allowing two independent registers to be accessed in one single instruction executed in one clock cycle. The resulting architecture is more code efficient while achieving throughputs up to ten times faster than conventional CISC microcontrollers.

The AT90CAN32/64/128 provides the following features: 32K/64K/128K bytes of In-System Programmable Flash with Read-While-Write capabilities, 1K/2K/4K bytes EEPROM, 2K/4K/4K bytes SRAM, 53 general purpose I/O lines, 32 general purpose working registers, a CAN controller, Real Time Counter (RTC), four flexible Timer/Counters with compare modes and PWM, 2 USARTs, a byte oriented Two-wire Serial Interface, an 8-channel 10-bit ADC with optional differential input stage with programmable gain, a programmable Watchdog Timer with Internal Oscillator, an SPI serial port, IEEE std. 1149.1 compliant JTAG test interface, also used for accessing the On-chip Debug system and programming and five software selectable power saving modes.

The Idle mode stops the CPU while allowing the SRAM, Timer/Counters, SPI/CAN ports and interrupt system to continue functioning. The Power-down mode saves the register contents but freezes the Oscillator, disabling all other chip functions until the next interrupt or Hardware Reset. In Power-save mode, the asynchronous timer continues to run, allowing the user to maintain a timer base while the rest of the device is sleeping. The ADC Noise Reduction mode stops the CPU and all I/O modules except Asynchronous Timer and ADC, to minimize switching noise during ADC conversions. In Standby mode, the Crystal/Resonator Oscillator is running while the rest of the device is sleeping. This allows very fast start-up combined with low power consumption.

The device is manufactured using Atmel's high-density nonvolatile memory technology. The On-chip ISP Flash allows the program memory to be reprogrammed in-system through an SPI serial interface, by a conventional nonvolatile memory programmer, or by an On-chip Boot program running on the AVR core. The boot program can use any interface to download the application program in the application Flash memory. Software in the Boot Flash section will continue to run while the Application Flash section is updated, providing true Read-While-Write operation. By

combining an 8-bit RISC CPU with In-System Self-Programmable Flash on a monolithic chip, the Atmel AT90CAN32/64/128 is a powerful microcontroller that provides a highly flexible and cost effective solution to many embedded control applications.

The AT90CAN32/64/128 AVR is supported with a full suite of program and system development tools including: C compilers, macro assemblers, program debugger/simulators, in-circuit emulators, and evaluation kits.

## 1.3 Disclaimer

Typical values contained in this datasheet are based on simulations and characterization of other AVR microcontrollers manufactured on the same process technology. Min and Max values will be available after the device is characterized.

## 1.4 Block Diagram

Figure 1-1. Block Diagram

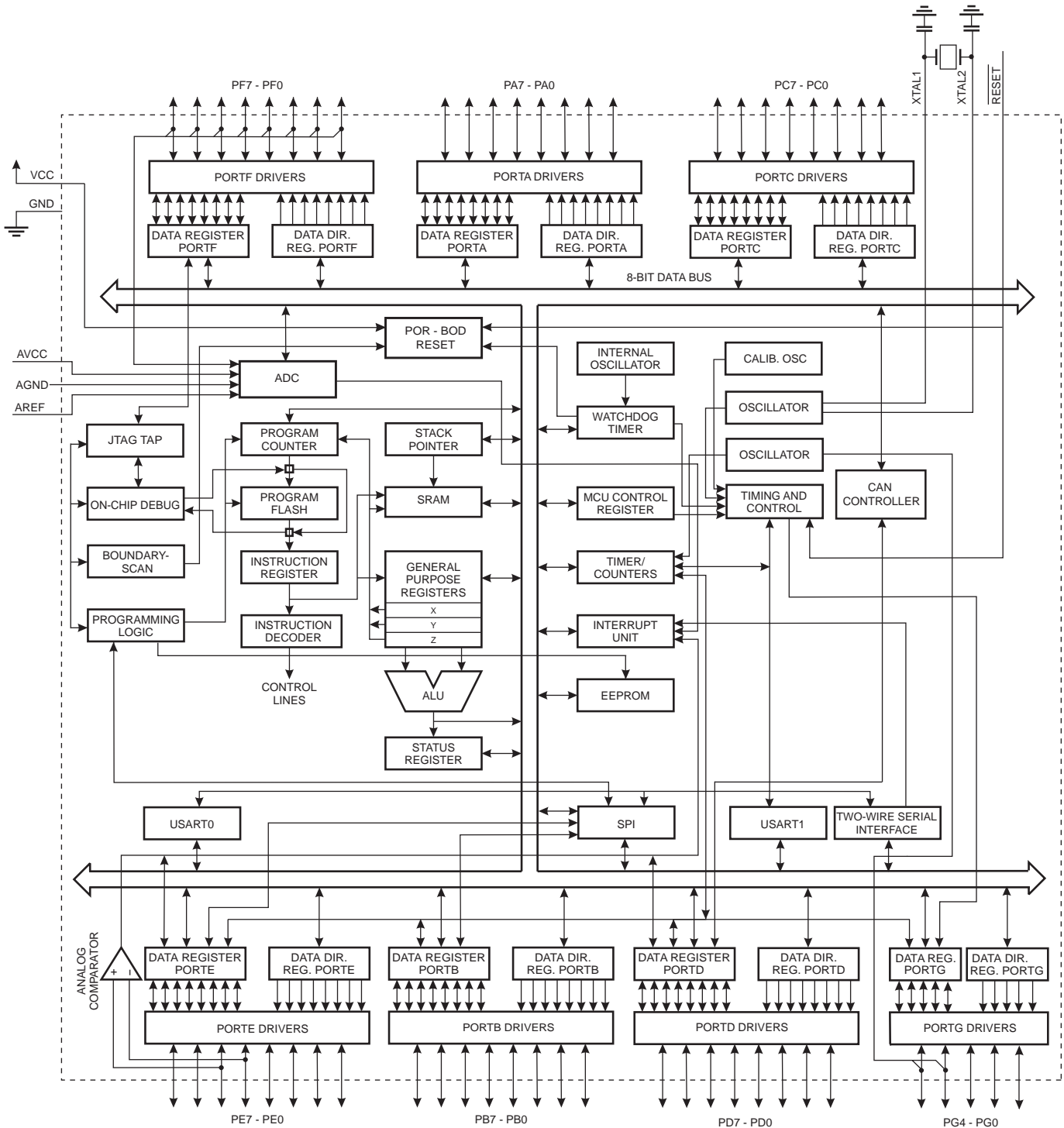

## 1.5 Pin Configurations

Figure 1-2. Pinout AT90CAN32/64/128 - TQFP

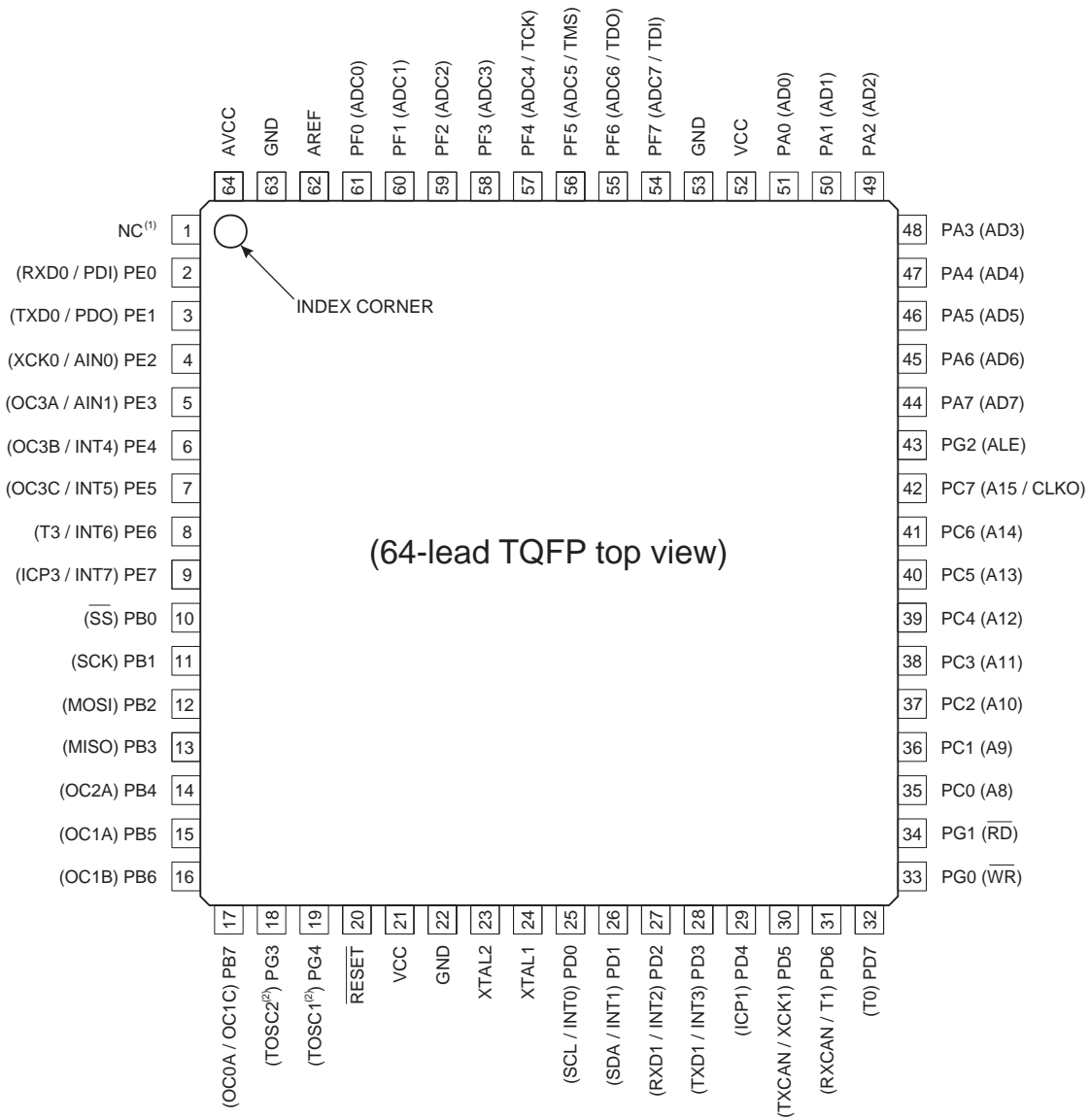

<sup>(1)</sup> NC = Do not connect (May be used in future devices)

<sup>(2)</sup> Timer2 Oscillator

Figure 1-3. Pinout AT90CAN32/64/128 - QFN

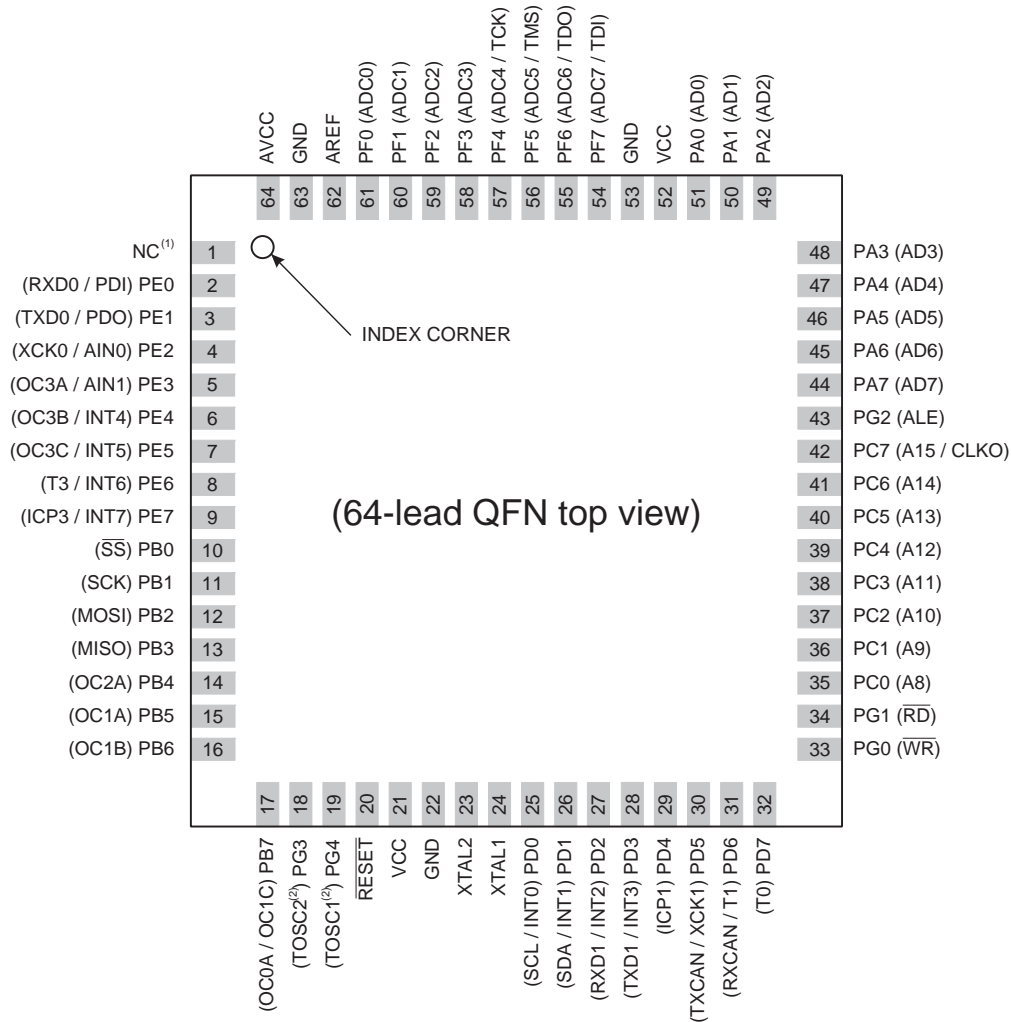

<sup>(1)</sup>NC = Do not connect (May be used in future devices)

<sup>(2)</sup>Timer2 Oscillator

Note: The large center pad underneath the QFN package is made of metal and internally connected to GND. It should be soldered or glued to the board to ensure good mechanical stability. If the center pad is left unconnected, the package might loosen from the board.

## 1.6 Pin Descriptions

### 1.6.1 VCC

Digital supply voltage.

### 1.6.2 GND

Ground.

**1.6.3 Port A (PA7..PA0)**

Port A is an 8-bit bi-directional I/O port with internal pull-up resistors (selected for each bit). The Port A output buffers have symmetrical drive characteristics with both high sink and source capability. As inputs, Port A pins that are externally pulled low will source current if the pull-up resistors are activated. The Port A pins are tri-stated when a reset condition becomes active, even if the clock is not running.

Port A also serves the functions of various special features of the AT90CAN32/64/128 as listed on [page 74](#).

**1.6.4 Port B (PB7..PB0)**

Port B is an 8-bit bi-directional I/O port with internal pull-up resistors (selected for each bit). The Port B output buffers have symmetrical drive characteristics with both high sink and source capability. As inputs, Port B pins that are externally pulled low will source current if the pull-up resistors are activated. The Port B pins are tri-stated when a reset condition becomes active, even if the clock is not running.

Port B also serves the functions of various special features of the AT90CAN32/64/128 as listed on [page 76](#).

**1.6.5 Port C (PC7..PC0)**

Port C is an 8-bit bi-directional I/O port with internal pull-up resistors (selected for each bit). The Port C output buffers have symmetrical drive characteristics with both high sink and source capability. As inputs, Port C pins that are externally pulled low will source current if the pull-up resistors are activated. The Port C pins are tri-stated when a reset condition becomes active, even if the clock is not running.

Port C also serves the functions of special features of the AT90CAN32/64/128 as listed on [page 78](#).

**1.6.6 Port D (PD7..PD0)**

Port D is an 8-bit bi-directional I/O port with internal pull-up resistors (selected for each bit). The Port D output buffers have symmetrical drive characteristics with both high sink and source capability. As inputs, Port D pins that are externally pulled low will source current if the pull-up resistors are activated. The Port D pins are tri-stated when a reset condition becomes active, even if the clock is not running.

Port D also serves the functions of various special features of the AT90CAN32/64/128 as listed on [page 80](#).

**1.6.7 Port E (PE7..PE0)**

Port E is an 8-bit bi-directional I/O port with internal pull-up resistors (selected for each bit). The Port E output buffers have symmetrical drive characteristics with both high sink and source capability. As inputs, Port E pins that are externally pulled low will source current if the pull-up resistors are activated. The Port E pins are tri-stated when a reset condition becomes active, even if the clock is not running.

Port E also serves the functions of various special features of the AT90CAN32/64/128 as listed on [page 83](#).

**1.6.8 Port F (PF7..PF0)**

Port F serves as the analog inputs to the A/D Converter.

Port F also serves as an 8-bit bi-directional I/O port, if the A/D Converter is not used. Port pins can provide internal pull-up resistors (selected for each bit). The Port F output buffers have symmetrical drive characteristics with both high sink and source capability. As inputs, Port F pins that are externally pulled low will source current if the pull-up resistors are activated. The Port F pins are tri-stated when a reset condition becomes active, even if the clock is not running.

Port F also serves the functions of the JTAG interface. If the JTAG interface is enabled, the pull-up resistors on pins PF7(TDI), PF5(TMS), and PF4(TCK) will be activated even if a reset occurs.

### 1.6.9 Port G (PG4..PG0)

Port G is a 5-bit I/O port with internal pull-up resistors (selected for each bit). The Port G output buffers have symmetrical drive characteristics with both high sink and source capability. As inputs, Port G pins that are externally pulled low will source current if the pull-up resistors are activated. The Port G pins are tri-stated when a reset condition becomes active, even if the clock is not running.

Port G also serves the functions of various special features of the AT90CAN32/64/128 as listed on [page 88](#).

### 1.6.10 RESET

Reset input. A low level on this pin for longer than the minimum pulse length will generate a reset. The minimum pulse length is given in characteristics. Shorter pulses are not guaranteed to generate a reset. The I/O ports of the AVR are immediately reset to their initial state even if the clock is not running. The clock is needed to reset the rest of the AT90CAN32/64/128.

### 1.6.11 XTAL1

Input to the inverting Oscillator amplifier and input to the internal clock operating circuit.

### 1.6.12 XTAL2

Output from the inverting Oscillator amplifier.

### 1.6.13 AVCC

AVCC is the supply voltage pin for the A/D Converter on Port F. It should be externally connected to  $V_{CC}$ , even if the ADC is not used. If the ADC is used, it should be connected to  $V_{CC}$  through a low-pass filter.

### 1.6.14 AREF

This is the analog reference pin for the A/D Converter.

## 2. About Code Examples

This documentation contains simple code examples that briefly show how to use various parts of the device. These code examples assume that the part specific header file is included before compilation. Be aware that not all C compiler vendors include bit definitions in the header files and interrupt handling in C is compiler dependent. Please confirm with the C compiler documentation for more details.



### 3. Register Summary

Address	Name	Bit 7	Bit 6	Bit 5	Bit 4	Bit 3	Bit 2	Bit 1	Bit 0	Page
(0xFF)	Reserved									
(0xFE)	Reserved									
(0xFD)	Reserved									
(0xFC)	Reserved									
(0xFB)	Reserved									
(0xFA)	CANMSG	MSG 7	MSG 6	MSG 5	MSG 4	MSG 3	MSG 2	MSG 1	MSG 0	page 266
(0xF9)	CANSTMH	TIMSTM15	TIMSTM14	TIMSTM13	TIMSTM12	TIMSTM11	TIMSTM10	TIMSTM9	TIMSTM8	page 266
(0xF8)	CANSTML	TIMSTM7	TIMSTM6	TIMSTM5	TIMSTM4	TIMSTM3	TIMSTM2	TIMSTM1	TIMSTM0	page 266
(0xF7)	CANIDM1	IDMSK28	IDMSK27	IDMSK26	IDMSK25	IDMSK24	IDMSK23	IDMSK22	IDMSK21	page 265
(0xF6)	CANIDM2	IDMSK20	IDMSK19	IDMSK18	IDMSK17	IDMSK16	IDMSK15	IDMSK14	IDMSK13	page 265
(0xF5)	CANIDM3	IDMSK12	IDMSK11	IDMSK10	IDMSK9	IDMSK8	IDMSK7	IDMSK6	IDMSK5	page 265
(0xF4)	CANIDM4	IDMSK4	IDMSK3	IDMSK2	IDMSK1	IDMSK0	RTRMSK	–	IDEMSK	page 265
(0xF3)	CANIDT1	IDT28	IDT27	IDT26	IDT25	IDT24	IDT23	IDT22	IDT21	page 263
(0xF2)	CANIDT2	IDT20	IDT19	IDT18	IDT17	IDT16	IDT15	IDT14	IDT13	page 263
(0xF1)	CANIDT3	IDT12	IDT11	IDT10	IDT9	IDT8	IDT7	IDT6	IDT5	page 263
(0xF0)	CANIDT4	IDT4	IDT3	IDT2	IDT1	IDT0	RTRTAG	RB1TAG	RB0TAG	page 263
(0xEF)	CANCDMOB	CONMOB1	CONMOB0	RPLV	IDE	DLC3	DLC2	DLC1	DLC0	page 262
(0xEE)	CANSTMOB	DLCW	TXOK	RXOK	BERR	SERR	CERR	FERR	AERR	page 261
(0xED)	CANPAGE	MOBNB3	MOBNB2	MOBNB1	MOBNB0	AINC	INDX2	INDX1	INDX0	page 260
(0xEC)	CANHPMOB	HPMOB3	HPMOB2	HPMOB1	HPMOB0	CGP3	CGP2	CGP1	CGP0	page 260
(0xEB)	CANREC	REC7	REC6	REC5	REC4	REC3	REC2	REC1	REC0	page 260
(0xEA)	CANTEC	TEC7	TEC6	TEC5	TEC4	TEC3	TEC2	TEC1	TEC0	page 260
(0xE9)	CANTTCH	TIMTTC15	TIMTTC14	TIMTTC13	TIMTTC12	TIMTTC11	TIMTTC10	TIMTTC9	TIMTTC8	page 260
(0xE8)	CANTTCL	TIMTTC7	TIMTTC6	TIMTTC5	TIMTTC4	TIMTTC3	TIMTTC2	TIMTTC1	TIMTTC0	page 260
(0xE7)	CANTIMH	CANTIM15	CANTIM14	CANTIM13	CANTIM12	CANTIM11	CANTIM10	CANTIM9	CANTIM8	page 259
(0xE6)	CANTIML	CANTIM7	CANTIM6	CANTIM5	CANTIM4	CANTIM3	CANTIM2	CANTIM1	CANTIM0	page 259
(0xE5)	CANTCON	TPRSC7	TPRSC6	TPRSC5	TPRSC4	TPRSC3	TPRSC2	TPRSC1	TPRSC0	page 259
(0xE4)	CANBT3	–	PHS22	PHS21	PHS20	PHS12	PHS11	PHS10	SMP	page 258
(0xE3)	CANBT2	–	SJW1	SJW0	–	PRS2	PRS1	PRS0	–	page 258
(0xE2)	CANBT1	–	BRP5	BRP4	BRP3	BRP2	BRP1	BRP0	–	page 257
(0xE1)	CANSIT1	–	SIT14	SIT13	SIT12	SIT11	SIT10	SIT9	SIT8	page 257
(0xE0)	CANSIT2	SIT7	SIT6	SIT5	SIT4	SIT3	SIT2	SIT1	SIT0	page 257
(0xDF)	CANIE1	–	IEMOB14	IEMOB13	IEMOB12	IEMOB11	IEMOB10	IEMOB9	IEMOB8	page 257
(0xDE)	CANIE2	IEMOB7	IEMOB6	IEMOB5	IEMOB4	IEMOB3	IEMOB2	IEMOB1	IEMOB0	page 257
(0xDD)	CANEN1	–	ENMOB14	ENMOB13	ENMOB12	ENMOB11	ENMOB10	ENMOB9	ENMOB8	page 256
(0xDC)	CANEN2	ENMOB7	ENMOB6	ENMOB5	ENMOB4	ENMOB3	ENMOB2	ENMOB1	ENMOB0	page 256
(0xDB)	CANGIE	ENIT	ENBOFF	ENRX	ENTX	ENERR	ENBX	ENERG	ENOVRT	page 255
(0xDA)	CANGIT	CANIT	BOFFIT	OVRTIM	BXOK	SERG	CERG	FERG	AERG	page 254
(0xD9)	CANGSTA	–	OVRG	–	TXBSY	RXBSY	ENFG	BOFF	ERRP	page 253
(0xD8)	CANGCON	ABRQ	OVRQ	TTC	SYNTTC	LISTEN	TEST	ENA/STB	SWRES	page 252
(0xD7)	Reserved									
(0xD6)	Reserved									
(0xD5)	Reserved									
(0xD4)	Reserved									
(0xD3)	Reserved									
(0xD2)	Reserved									
(0xD1)	Reserved									
(0xD0)	Reserved									
(0xCF)	Reserved									
(0xCE)	UDR1	UDR17	UDR16	UDR15	UDR14	UDR13	UDR12	UDR11	UDR10	page 195
(0xCD)	UBRR1H	–	–	–	–	UBRR111	UBRR110	UBRR19	UBRR18	page 199
(0xCC)	UBRR1L	UBRR17	UBRR16	UBRR15	UBRR14	UBRR13	UBRR12	UBRR11	UBRR10	page 199
(0xCB)	Reserved									
(0xCA)	UCSR1C	–	UMSEL1	UPM11	UPM10	USBS1	UCSZ11	UCSZ10	UCPOL1	page 198
(0xC9)	UCSR1B	RXCIE1	TXCIE1	UDRIE1	RXEN1	TXEN1	UCSZ12	RXB81	TXB81	page 197
(0xC8)	UCSR1A	RXC1	TXC1	UDRE1	FE1	DOR1	UPE1	U2X1	MPCM1	page 195
(0xC7)	Reserved									
(0xC6)	UDR0	UDR07	UDR06	UDR05	UDR04	UDR03	UDR02	UDR01	UDR00	page 195
(0xC5)	UBRR0H	–	–	–	–	UBRR011	UBRR010	UBRR09	UBRR08	page 199
(0xC4)	UBRR0L	UBRR07	UBRR06	UBRR05	UBRR04	UBRR03	UBRR02	UBRR01	UBRR00	page 199
(0xC3)	Reserved									
(0xC2)	UCSR0C	–	UMSEL0	UPM01	UPM00	USBS0	UCSZ01	UCSZ00	UCPOL0	page 197
(0xC1)	UCSR0B	RXCIE0	TXCIE0	UDRIE0	RXEN0	TXEN0	UCSZ02	RXB80	TXB80	page 196
(0xC0)	UCSR0A	RXC0	TXC0	UDRE0	FE0	DOR0	UPE0	U2X0	MPCM0	page 195
(0xBF)	Reserved									



Address	Name	Bit 7	Bit 6	Bit 5	Bit 4	Bit 3	Bit 2	Bit 1	Bit 0	Page
(0xBE)	Reserved									
(0xBD)	Reserved									
(0xBC)	TWCR	TWINT	TWEA	TWSTA	TWSTO	TWWC	TWEN	–	TWIE	page 212
(0xBB)	TWDR	TWDR7	TWDR6	TWDR5	TWDR4	TWDR3	TWDR2	TWDR1	TWDR0	page 214
(0xBA)	TWAR	TWAR6	TWAR5	TWAR4	TWAR3	TWAR2	TWAR1	TWAR0	TWGE	page 214
(0xB9)	TWSR	TWS7	TWS6	TWS5	TWS4	TWS3	–	TWPS1	TWPS0	page 213
(0xB8)	TWBR	TWBR7	TWBR6	TWBR5	TWBR4	TWBR3	TWBR2	TWBR1	TWBR0	page 212
(0xB7)	Reserved									
(0xB6)	ASSR	–	–	–	EXCLK	AS2	TCN2UB	OCR2UB	TCR2UB	page 160
(0xB5)	Reserved									
(0xB4)	Reserved									
(0xB3)	OCR2A	OCR2A7	OCR2A6	OCR2A5	OCR2A4	OCR2A3	OCR2A2	OCR2A1	OCR2A0	page 159
(0xB2)	TCNT2	TCNT27	TCNT26	TCNT25	TCNT24	TCNT23	TCNT22	TCNT21	TCNT20	page 159
(0xB1)	Reserved									
(0xB0)	TCCR2A	FOC2A	WGM20	COM2A1	COM2A0	WGM21	CS22	CS21	CS20	page 164
(0xAF)	Reserved									
(0xAE)	Reserved									
(0xAD)	Reserved									
(0xAC)	Reserved									
(0xAB)	Reserved									
(0xAA)	Reserved									
(0xA9)	Reserved									
(0xA8)	Reserved									
(0xA7)	Reserved									
(0xA6)	Reserved									
(0xA5)	Reserved									
(0xA4)	Reserved									
(0xA3)	Reserved									
(0xA2)	Reserved									
(0xA1)	Reserved									
(0xA0)	Reserved									
(0x9F)	Reserved									
(0x9E)	Reserved									
(0x9D)	OCR3CH	OCR3C15	OCR3C14	OCR3C13	OCR3C12	OCR3C11	OCR3C10	OCR3C9	OCR3C8	page 141
(0x9C)	OCR3CL	OCR3C7	OCR3C6	OCR3C5	OCR3C4	OCR3C3	OCR3C2	OCR3C1	OCR3C0	page 141
(0x9B)	OCR3BH	OCR3B15	OCR3B14	OCR3B13	OCR3B12	OCR3B11	OCR3B10	OCR3B9	OCR3B8	page 141
(0x9A)	OCR3BL	OCR3B7	OCR3B6	OCR3B5	OCR3B4	OCR3B3	OCR3B2	OCR3B1	OCR3B0	page 141
(0x99)	OCR3AH	OCR3A15	OCR3A14	OCR3A13	OCR3A12	OCR3A11	OCR3A10	OCR3A9	OCR3A8	page 141
(0x98)	OCR3AL	OCR3A7	OCR3A6	OCR3A5	OCR3A4	OCR3A3	OCR3A2	OCR3A1	OCR3A0	page 141
(0x97)	ICR3H	ICR315	ICR314	ICR313	ICR312	ICR311	ICR310	ICR39	ICR38	page 142
(0x96)	ICR3L	ICR37	ICR36	ICR35	ICR34	ICR33	ICR32	ICR31	ICR30	page 142
(0x95)	TCNT3H	TCNT315	TCNT314	TCNT313	TCNT312	TCNT311	TCNT310	TCNT39	TCNT38	page 140
(0x94)	TCNT3L	TCNT37	TCNT36	TCNT35	TCNT34	TCNT33	TCNT32	TCNT31	TCNT30	page 140
(0x93)	Reserved									
(0x92)	TCCR3C	FOC3A	FOC3B	FOC3C	–	–	–	–	–	page 140
(0x91)	TCCR3B	ICNC3	ICES3	–	WGM33	WGM32	CS32	CS31	CS30	page 138
(0x90)	TCCR3A	COM3A1	COM3A0	COM3B1	COM3B0	COM3C1	COM3C0	WGM31	WGM30	page 135
(0x8F)	Reserved									
(0x8E)	Reserved									
(0x8D)	OCR1CH	OCR1C15	OCR1C14	OCR1C13	OCR1C12	OCR1C11	OCR1C10	OCR1C9	OCR1C8	page 141
(0x8C)	OCR1CL	OCR1C7	OCR1C6	OCR1C5	OCR1C4	OCR1C3	OCR1C2	OCR1C1	OCR1C0	page 141
(0x8B)	OCR1BH	OCR1B15	OCR1B14	OCR1B13	OCR1B12	OCR1B11	OCR1B10	OCR1B9	OCR1B8	page 141
(0x8A)	OCR1BL	OCR1B7	OCR1B6	OCR1B5	OCR1B4	OCR1B3	OCR1B2	OCR1B1	OCR1B0	page 141
(0x89)	OCR1AH	OCR1A15	OCR1A14	OCR1A13	OCR1A12	OCR1A11	OCR1A10	OCR1A9	OCR1A8	page 141
(0x88)	OCR1AL	OCR1A7	OCR1A6	OCR1A5	OCR1A4	OCR1A3	OCR1A2	OCR1A1	OCR1A0	page 141
(0x87)	ICR1H	ICR115	ICR114	ICR113	ICR112	ICR111	ICR110	ICR19	ICR18	page 142
(0x86)	ICR1L	ICR17	ICR16	ICR15	ICR14	ICR13	ICR12	ICR11	ICR10	page 142
(0x85)	TCNT1H	TCNT115	TCNT114	TCNT113	TCNT112	TCNT111	TCNT110	TCNT19	TCNT18	page 140
(0x84)	TCNT1L	TCNT17	TCNT16	TCNT15	TCNT14	TCNT13	TCNT12	TCNT11	TCNT10	page 140
(0x83)	Reserved									
(0x82)	TCCR1C	FOC1A	FOC1B	FOC1C	–	–	–	–	–	page 139
(0x81)	TCCR1B	ICNC1	ICES1	–	WGM13	WGM12	CS12	CS11	CS10	page 138
(0x80)	TCCR1A	COM1A1	COM1A0	COM1B1	COM1B0	COM1C1	COM1C0	WGM11	WGM10	page 135
(0x7F)	DIDR1	–	–	–	–	–	–	AIN1D	AIN0D	page 272
(0x7E)	DIDR0	ADC7D	ADC6D	ADC5D	ADC4D	ADC3D	ADC2D	ADC1D	ADC0D	page 292
(0x7D)	Reserved									

Address	Name	Bit 7	Bit 6	Bit 5	Bit 4	Bit 3	Bit 2	Bit 1	Bit 0	Page
(0x7C)	ADMUX	REFS1	REFS0	ADLAR	MUX4	MUX3	MUX2	MUX1	MUX0	<a href="#">page 287</a>
(0x7B)	ADCSRB	–	ACME	–	–	–	ADTS2	ADTS1	ADTS0	<a href="#">page 291, 269</a>
(0x7A)	ADCSRA	ADEN	ADSC	ADATE	ADIF	ADIE	ADPS2	ADPS1	ADPS0	<a href="#">page 289</a>
(0x79)	ADCH	- / ADC9	- / ADC8	- / ADC7	- / ADC6	- / ADC5	- / ADC4	ADC9 / ADC3	ADC8 / ADC2	<a href="#">page 290</a>
(0x78)	ADCL	ADC7 / ADC1	ADC6 / ADC0	ADC5 / -	ADC4 / -	ADC3 / -	ADC2 / -	ADC1 / -	ADC0 /	<a href="#">page 290</a>
(0x77)	Reserved									
(0x76)	Reserved									
(0x75)	XMCRB	XMBK	–	–	–	–	XMM2	XMM1	XMM0	<a href="#">page 33</a>
(0x74)	XMCRA	SRE	SRL2	SRL1	SRL0	SRW11	SRW10	SRW01	SRW00	<a href="#">page 32</a>
(0x73)	Reserved									
(0x72)	Reserved									
(0x71)	TIMSK3	–	–	ICIE3	–	OCIE3C	OCIE3B	OCIE3A	TOIE3	<a href="#">page 142</a>
(0x70)	TIMSK2	–	–	–	–	–	–	OCIE2A	TOIE2	<a href="#">page 162</a>
(0x6F)	TIMSK1	–	–	ICIE1	–	OCIE1C	OCIE1B	OCIE1A	TOIE1	<a href="#">page 142</a>
(0x6E)	TIMSK0	–	–	–	–	–	–	OCIE0A	TOIE0	<a href="#">page 112</a>
(0x6D)	Reserved									
(0x6C)	Reserved									
(0x6B)	Reserved									
(0x6A)	EICRB	ISC71	ISC70	ISC61	ISC60	ISC51	ISC50	ISC41	ISC40	<a href="#">page 94</a>
(0x69)	EICRA	ISC31	ISC30	ISC21	ISC20	ISC11	ISC10	ISC01	ISC00	<a href="#">page 93</a>
(0x68)	Reserved									
(0x67)	Reserved									
(0x66)	OSCCAL	–	CAL6	CAL5	CAL4	CAL3	CAL2	CAL1	CAL0	<a href="#">page 42</a>
(0x65)	Reserved									
(0x64)	Reserved									
(0x63)	Reserved									
(0x62)	Reserved									
(0x61)	CLKPR	CLKPCE	–	–	–	CLKPS3	CLKPS2	CLKPS1	CLKPS0	<a href="#">page 44</a>
(0x60)	WDTCR	–	–	–	WDCE	WDE	WDP2	WDP1	WDP0	<a href="#">page 58</a>
0x3F (0x5F)	SREG	I	T	H	S	V	N	Z	C	<a href="#">page 11</a>
0x3E (0x5E)	SPH	SP15	SP14	SP13	SP12	SP11	SP10	SP9	SP8	<a href="#">page 14</a>
0x3D (0x5D)	SPL	SP7	SP6	SP5	SP4	SP3	SP2	SP1	SP0	<a href="#">page 14</a>
0x3C (0x5C)	Reserved									
0x3B (0x5B)	RAMPZ <sup>(1)</sup>	–	–	–	–	–	–	–	RAMPZ0	<a href="#">page 13</a>
0x3A (0x5A)	Reserved									
0x39 (0x59)	Reserved									
0x38 (0x58)	Reserved									
0x37 (0x57)	SPMCSR	SPMIE	RWWWSB	–	RWWWSRE	BLBSET	PGWRT	PGERS	SPMEN	<a href="#">page 326</a>
0x36 (0x56)	Reserved									
0x35 (0x55)	MCUCR	JTD	–	–	PUD	–	–	IVSEL	IVCE	<a href="#">page 64, 73, 304</a>
0x34 (0x54)	MCUSR	–	–	–	JTRF	WDRF	BORF	EXTRF	PORF	<a href="#">page 56, 304</a>
0x33 (0x53)	SMCR	–	–	–	–	SM2	SM1	SM0	SE	<a href="#">page 46</a>
0x32 (0x52)	Reserved									
0x31 (0x51)	OCDR	IDRD/OCDR7	OCDR6	OCDR5	OCDR4	OCDR3	OCDR2	OCDR1	OCDR0	<a href="#">page 299</a>
0x30 (0x50)	ACSR	ACD	ACBG	ACO	ACI	ACIE	ACIC	ACIS1	ACIS0	<a href="#">page 270</a>
0x2F (0x4F)	Reserved									
0x2E (0x4E)	SPDR	SPD7	SPD6	SPD5	SPD4	SPD3	SPD2	SPD1	SPD0	<a href="#">page 175</a>
0x2D (0x4D)	SPSR	SPIF	WCOL	–	–	–	–	–	SPI2X	<a href="#">page 175</a>
0x2C (0x4C)	SPCR	SPIE	SPE	DORD	MSTR	CPOL	CPHA	SPR1	SPR0	<a href="#">page 173</a>
0x2B (0x4B)	GPIOR2	GPIOR27	GPIOR26	GPIOR25	GPIOR24	GPIOR23	GPIOR22	GPIOR21	GPIOR20	<a href="#">page 36</a>
0x2A (0x4A)	GPIOR1	GPIOR17	GPIOR16	GPIOR15	GPIOR14	GPIOR13	GPIOR12	GPIOR11	GPIOR10	<a href="#">page 36</a>
0x29 (0x49)	Reserved									
0x28 (0x48)	Reserved									
0x27 (0x47)	OCR0A	OCR0A7	OCR0A6	OCR0A5	OCR0A4	OCR0A3	OCR0A2	OCR0A1	OCR0A0	<a href="#">page 112</a>
0x26 (0x46)	TCNT0	TCNT07	TCNT06	TCNT05	TCNT04	TCNT03	TCNT02	TCNT01	TCNT00	<a href="#">page 111</a>
0x25 (0x45)	Reserved									
0x24 (0x44)	TCCR0A	FOC0A	WGM00	COM0A1	COM0A0	WGM01	CS02	CS01	CS00	<a href="#">page 109</a>
0x23 (0x43)	GTCCR	TSM	–	–	–	–	–	PSR2	PSR310	<a href="#">page 98, 164</a>
0x22 (0x42)	EEARH <sup>(2)</sup>	–	–	–	–	EEAR11	EEAR10	EEAR9	EEAR8	<a href="#">page 22</a>
0x21 (0x41)	EEARL	EEAR7	EEAR6	EEAR5	EEAR4	EEAR3	EEAR2	EEAR1	EEAR0	<a href="#">page 22</a>
0x20 (0x40)	EEDR	EEDR7	EEDR6	EEDR5	EEDR4	EEDR3	EEDR2	EEDR1	EEDR0	<a href="#">page 23</a>
0x1F (0x3F)	EEDR	–	–	–	–	EERIE	EEMWE	EWE	EERE	<a href="#">page 23</a>
0x1E (0x3E)	GPIOR0	GPIOR07	GPIOR06	GPIOR05	GPIOR04	GPIOR03	GPIOR02	GPIOR01	GPIOR00	<a href="#">page 36</a>
0x1D (0x3D)	EIMSK	INT7	INT6	INT5	INT4	INT3	INT2	INT1	INT0	<a href="#">page 95</a>
0x1C (0x3C)	EIFR	INTF7	INTF6	INTF5	INTF4	INTF3	INTF2	INTF1	INTF0	<a href="#">page 95</a>
0x1B (0x3B)	Reserved									



Address	Name	Bit 7	Bit 6	Bit 5	Bit 4	Bit 3	Bit 2	Bit 1	Bit 0	Page
0x1A (0x3A)	Reserved									
0x19 (0x39)	Reserved									
0x18 (0x38)	TIFR3	–	–	ICF3	–	OCF3C	OCF3B	OCF3A	TOV3	<a href="#">page 143</a>
0x17 (0x37)	TIFR2	–	–	–	–	–	–	OCF2A	TOV2	<a href="#">page 162</a>
0x16 (0x36)	TIFR1	–	–	ICF1	–	OCF1C	OCF1B	OCF1A	TOV1	<a href="#">page 143</a>
0x15 (0x35)	TIFR0	–	–	–	–	–	–	OCF0A	TOV0	<a href="#">page 112</a>
0x14 (0x34)	PORTG	–	–	–	PORTG4	PORTG3	PORTG2	PORTG1	PORTG0	<a href="#">page 92</a>
0x13 (0x33)	DDRG	–	–	–	DDG4	DDG3	DDG2	DDG1	DDG0	<a href="#">page 92</a>
0x12 (0x32)	PING	–	–	–	PING4	PING3	PING2	PING1	PING0	<a href="#">page 92</a>
0x11 (0x31)	PORTF	PORTF7	PORTF6	PORTF5	PORTF4	PORTF3	PORTF2	PORTF1	PORTF0	<a href="#">page 91</a>
0x10 (0x30)	DDRF	DDF7	DDF6	DDF5	DDF4	DDF3	DDF2	DDF1	DDF0	<a href="#">page 91</a>
0x0F (0x2F)	PINF	PINF7	PINF6	PINF5	PINF4	PINF3	PINF2	PINF1	PINF0	<a href="#">page 92</a>
0x0E (0x2E)	PORTE	PORTE7	PORTE6	PORTE5	PORTE4	PORTE3	PORTE2	PORTE1	PORTE0	<a href="#">page 91</a>
0x0D (0x2D)	DDE	DDE7	DDE6	DDE5	DDE4	DDE3	DDE2	DDE1	DDE0	<a href="#">page 91</a>
0x0C (0x2C)	PINE	PINE7	PINE6	PINE5	PINE4	PINE3	PINE2	PINE1	PINE0	<a href="#">page 91</a>
0x0B (0x2B)	PORTD	PORTD7	PORTD6	PORTD5	PORTD4	PORTD3	PORTD2	PORTD1	PORTD0	<a href="#">page 91</a>
0x0A (0x2A)	DDRD	DDD7	DDD6	DDD5	DDD4	DDD3	DDD2	DDD1	DDD0	<a href="#">page 91</a>
0x09 (0x29)	PIND	PIND7	PIND6	PIND5	PIND4	PIND3	PIND2	PIND1	PIND0	<a href="#">page 91</a>
0x08 (0x28)	PORTC	PORTC7	PORTC6	PORTC5	PORTC4	PORTC3	PORTC2	PORTC1	PORTC0	<a href="#">page 90</a>
0x07 (0x27)	DDRC	DDC7	DDC6	DDC5	DDC4	DDC3	DDC2	DDC1	DDC0	<a href="#">page 90</a>
0x06 (0x26)	PINC	PINC7	PINC6	PINC5	PINC4	PINC3	PINC2	PINC1	PINC0	<a href="#">page 90</a>
0x05 (0x25)	PORTB	PORTB7	PORTB6	PORTB5	PORTB4	PORTB3	PORTB2	PORTB1	PORTB0	<a href="#">page 90</a>
0x04 (0x24)	DDRB	DDB7	DDB6	DDB5	DDB4	DDB3	DDB2	DDB1	DDB0	<a href="#">page 90</a>
0x03 (0x23)	PINB	PINB7	PINB6	PINB5	PINB4	PINB3	PINB2	PINB1	PINB0	<a href="#">page 90</a>
0x02 (0x22)	PORTA	PORTA7	PORTA6	PORTA5	PORTA4	PORTA3	PORTA2	PORTA1	PORTA0	<a href="#">page 89</a>
0x01 (0x21)	DDRA	DDA7	DDA6	DDA5	DDA4	DDA3	DDA2	DDA1	DDA0	<a href="#">page 90</a>
0x00 (0x20)	PINA	PINA7	PINA6	PINA5	PINA4	PINA3	PINA2	PINA1	PINA0	<a href="#">page 90</a>

- Notes:
1. Address bits exceeding PCMSB ([Table 25-11 on page 341](#)) are don't care.
  2. Address bits exceeding EEAMSB ([Table 25-12 on page 341](#)) are don't care.
  3. For compatibility with future devices, reserved bits should be written to zero if accessed. Reserved I/O memory addresses should never be written.
  4. I/O Registers within the address range 0x00 - 0x1F are directly bit-accessible using the SBI and CBI instructions. In these registers, the value of single bits can be checked by using the SBIS and SBIC instructions.
  5. Some of the status flags are cleared by writing a logical one to them. Note that, unlike most other AVRs, the CBI and SBI instructions will only operate on the specified bit, and can therefore be used on registers containing such status flags. The CBI and SBI instructions work with registers 0x00 to 0x1F only.
  6. When using the I/O specific commands IN and OUT, the I/O addresses 0x00 - 0x3F must be used. When addressing I/O Registers as data space using LD and ST instructions, 0x20 must be added to these addresses. The AT90CAN32/64/128 is a complex microcontroller with more peripheral units than can be supported within the 64 location reserved in Opcode for the IN and OUT instructions. For the Extended I/O space from 0x60 - 0xFF in SRAM, only the ST/STS/STD and LD/LDS/LDD instructions can be used.

## 4. Ordering Information

Ordering Code <sup>(1)</sup>	Speed (MHz)	Power Supply (V)	Package	Operation Range	Product Marking
AT90CAN32-16AI	16	2.7 - 5.5	A2 64	Industrial (-40° to +85°C)	AT90CAN32-16AI
AT90CAN32-16MI	16	2.7 - 5.5	Z64-1	Industrial (-40° to +85°C)	AT90CAN32-16MI
AT90CAN32-16AU	16	2.7 - 5.5	A2 64	Industrial (-40° to +85°C) Green	AT90CAN32-16AU
AT90CAN32-16MU	16	2.7 - 5.5	Z64-1	Industrial (-40° to +85°C) Green	AT90CAN32-16MU
AT90CAN64-16AI	16	2.7 - 5.5	A2 64	Industrial (-40° to +85°C)	AT90CAN64-16AI
AT90CAN64-16MI	16	2.7 - 5.5	Z64-2	Industrial (-40° to +85°C)	AT90CAN64-16MI
AT90CAN64-16AU	16	2.7 - 5.5	A2 64	Industrial (-40° to +85°C) Green	AT90CAN64-16AU
AT90CAN64-16MU	16	2.7 - 5.5	Z64-2	Industrial (-40° to +85°C) Green	AT90CAN64-16MU
AT90CAN128-16AI	16	2.7 - 5.5	A2 64	Industrial (-40° to +85°C)	AT90CAN128-16AI
AT90CAN128-16MI	16	2.7 - 5.5	Z64-2	Industrial (-40° to +85°C)	AT90CAN128-16MI
AT90CAN128-16AU	16	2.7 - 5.5	A2 64	Industrial (-40° to +85°C) Green	AT90CAN128-16AU
AT90CAN128-16MU	16	2.7 - 5.5	Z64-2	Industrial (-40° to +85°C) Green	AT90CAN128-16MU

Notes: 1. These devices can also be supplied in wafer form. Please contact your local Atmel sales office for detailed ordering information and minimum quantities.

## 5. Packaging Information

Package Type	
<b>A2 64</b>	64-Lead, Thin (1.0 mm / 0.03937 in) Plastic Gull Wing Quad Flat Package.
<b>Z64-1</b>	64-Lead, QFN, Exposed Die Attach Pad D2/E2: 5.4 ± 0.1mm / 0.212 ± 0.004 in.
<b>Z64-2</b>	64-Lead, QFN, Exposed Die Attach Pad D2/E2: 6.0 ± 0.1mm / 0.236 ± 0.004 in.

## 5.1 TQFP64

### 64 PINS THIN QUAD FLAT PACK

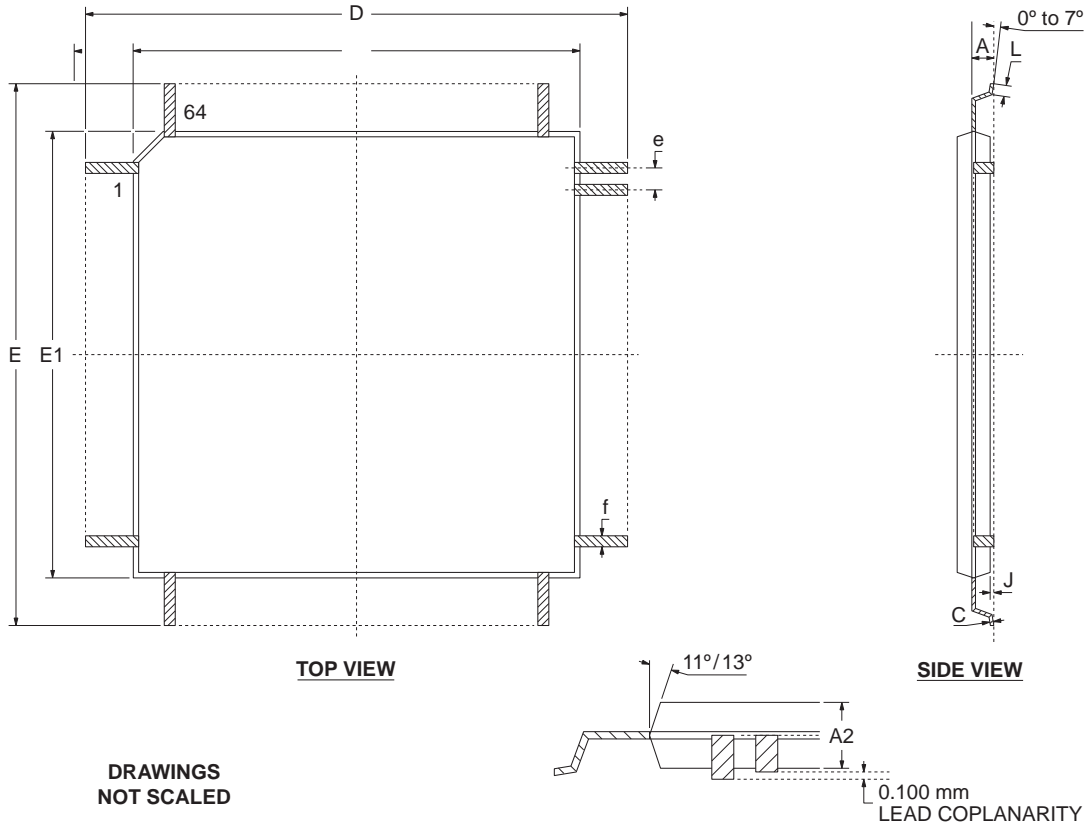

	MM		INCH	
	Min	Max	Min	Max
<b>A</b>	----	1.20	----	0.047
<b>A2</b>	0.95	1.05	0.037	0.041
<b>C</b>	0.09	0.20	0.004	0.008
<b>D</b>	16.00 BSC		0.630 BSC	
<b>D1</b>	14.00 BSC		0.551 BSC	
<b>E</b>	16.00 BSC		0.630 BSC	
<b>E1</b>	14.00 BSC		0.551 BSC	
<b>J</b>	0.05	0.15	0.002	0.006
<b>L</b>	0.45	0.75	0.018	0.030
<b>e</b>	0.80 BSC		0.0315 BSC	
<b>f</b>	0.30	0.45	0.012	0.018

## 5.2 QFN64

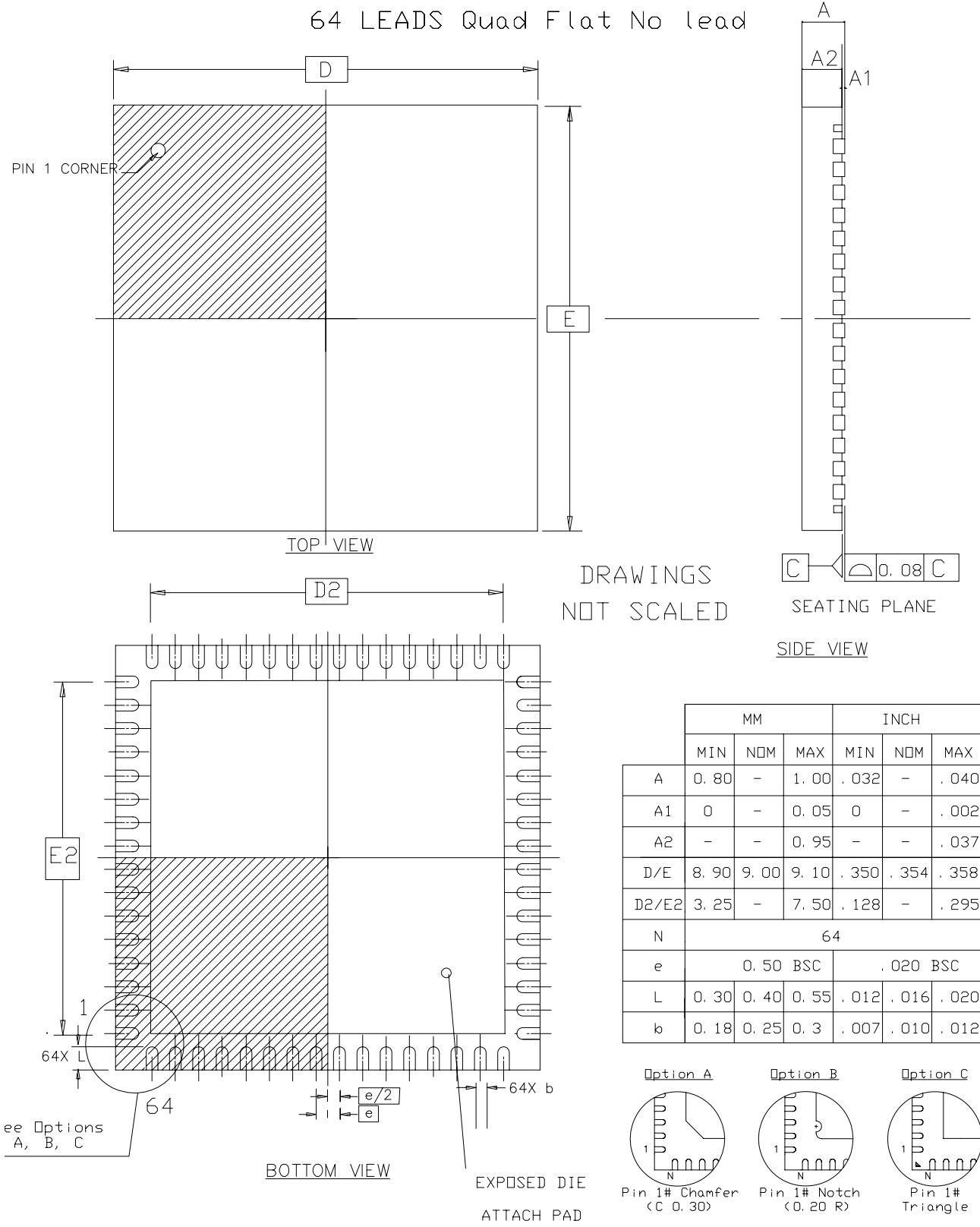

Compliant JEDEC Standard MD-220 variation VMMD-3

NOTES: QFN STANDARD NOTES

1. DIMENSIONING & TOLERANCING CONFORM TO ASME Y14.5M. – 1994.
2. DIMENSION  $b$  APPLIES TO METALLIZED TERMINAL AND IS MEASURED BETWEEN 0.15 AND 0.30 mm FROM TERMINAL TIP. IF THE TERMINAL HAS THE OPTIONAL RADIUS ON THE OTHER END OF THE TERMINAL, THE DIMENSION  $b$  SHOULD NOT BE MEASURED IN THAT RADIUS AREA.
3. MAX. PACKAGE WARPAGE IS 0.05mm.
4. MAXIMUM ALLOWABLE BURRS IS 0.076 mm IN ALL DIRECTIONS.
5. PIN #1 ID ON TOP WILL BE LASER MARKED.
6. THIS DRAWING CONFORMES TO JEDEC REGISTERED OUTLINE MO-220.
7. A MAXIMUM 0.15mm PULL BACK (L1) MAY BE PRESENT.  
L MINUS L1 TO BE EQUAL TO OR GREATER THAN 0.30 mm
8. THE TERMINAL #1 IDENTIFIER ARE OPTIONAL BUT MUST BE LOCATED WITHIN THE ZONE INDICATED  
THE TERMINAL #1 IDENTIFIER BE EITHER A MOLD OR MARKED FEATURE





## Headquarters

---

**Atmel Corporation**  
2325 Orchard Parkway  
San Jose, CA 95131  
USA  
Tel: 1(408) 441-0311  
Fax: 1(408) 487-2600

## International

---

**Atmel Asia**  
Room 1219  
Chinachem Golden Plaza  
77 Mody Road Tsimshatsui  
East Kowloon  
Hong Kong  
Tel: (852) 2721-9778  
Fax: (852) 2722-1369

**Atmel Europe**  
Le Krebs  
8, Rue Jean-Pierre Timbaud  
BP 309  
78054 Saint-Quentin-en-  
Yvelines Cedex  
France  
Tel: (33) 1-30-60-70-00  
Fax: (33) 1-30-60-71-11

**Atmel Japan**  
9F, Tonetsu Shinkawa Bldg.  
1-24-8 Shinkawa  
Chuo-ku, Tokyo 104-0033  
Japan  
Tel: (81) 3-3523-3551  
Fax: (81) 3-3523-7581

## Product Contact

---

**Web Site**  
[www.atmel.com](http://www.atmel.com)

**Technical Support**  
[avr@atmel.com](mailto:avr@atmel.com)

**Sales Contact**  
[www.atmel.com/contacts](http://www.atmel.com/contacts)

**Literature Requests**  
[www.atmel.com/literature](http://www.atmel.com/literature)

---

**Disclaimer:** The information in this document is provided in connection with Atmel products. No license, express or implied, by estoppel or otherwise, to any intellectual property right is granted by this document or in connection with the sale of Atmel products. **EXCEPT AS SET FORTH IN ATMEL'S TERMS AND CONDITIONS OF SALE LOCATED ON ATMEL'S WEB SITE, ATMEL ASSUMES NO LIABILITY WHATSOEVER AND DISCLAIMS ANY EXPRESS, IMPLIED OR STATUTORY WARRANTY RELATING TO ITS PRODUCTS INCLUDING, BUT NOT LIMITED TO, THE IMPLIED WARRANTY OF MERCHANTABILITY, FITNESS FOR A PARTICULAR PURPOSE, OR NON-INFRINGEMENT. IN NO EVENT SHALL ATMEL BE LIABLE FOR ANY DIRECT, INDIRECT, CONSEQUENTIAL, PUNITIVE, SPECIAL OR INCIDENTAL DAMAGES (INCLUDING, WITHOUT LIMITATION, DAMAGES FOR LOSS OF PROFITS, BUSINESS INTERRUPTION, OR LOSS OF INFORMATION) ARISING OUT OF THE USE OR INABILITY TO USE THIS DOCUMENT, EVEN IF ATMEL HAS BEEN ADVISED OF THE POSSIBILITY OF SUCH DAMAGES.** Atmel makes no representations or warranties with respect to the accuracy or completeness of the contents of this document and reserves the right to make changes to specifications and product descriptions at any time without notice. Atmel does not make any commitment to update the information contained herein. Unless specifically provided otherwise, Atmel products are not suitable for, and shall not be used in, automotive applications. Atmel's products are not intended, authorized, or warranted for use as components in applications intended to support or sustain life.

© 2008 Atmel Corporation. All rights reserved. Atmel®, logo and combinations thereof, and others are registered trademarks or trademarks of Atmel Corporation or its subsidiaries. Other terms and product names may be trademarks of others.